

**EVERGREEN LIGHTING**

ALL BEND RADIUS .030"

APPLICATION

DO NOT SCALE DRAWING

UNLESS OTHERWISE SPECIFIED:

DIMENSIONS ARE IN INCHES  
 TOLERANCES:  
 FRACTIONAL ± .003  
 ANGULAR: MACH ± .01 BEND ±  
 TWO PLACE DECIMAL ±  
 THREE PLACE DECIMAL ± .001

INTERPRET GEOMETRIC  
 TOLERANCING PER:

MATERIAL

FINISH

NAME

DATE

DRAWN

CHECKED

ENG APPR.

MFG APPR.

Q.A.

COMMENTS:

FIXTURE HEAD

TITLE:

DOM-PST30-40W-9-9AB3-RD-DIM-MSFS-ASSEMB

SIZE DWG. NO.

REV

**A** TICKET 25596

SCALE: 1:15 WEIGHT:

SHEET 1 OF 15

5

4

3

2

1

ITEM NO.	PART NUMBER	DESCRIPTION	QTY.	CUT
1	DOM-PST30-40W-9-9AB3-RD-DIM-MSFS-POST-CUSTOM FITTER	POST FITTER	1	
2	DOM-PST30-40W-9-9AB3-RD-DIM-MSFS-SPUN CONE	SPUN ALUMINUM 0.125"	1	
3	DOM-PST30-40W-9-9AB3-RD-DIM-MSFS-POST-DOME REFLECTOR	SPUN ALUMINUM 0.125"	1	
4	DOM-PST30-40W-9-9AB3-RD-DIM-MSFS-SPUN DOME BRACKET	SPUN ALUMINUM 0.125"	1	
5	DOM-PST30-40W-9-9AB3-RD-DIM-MSFS-POST-DOME REFLECTOR CONE	SPUN ALUMINUM 0.080"	1	
6	DOM-PST30-40W-9-9AB3-RD-DIM-MSFS-POST- INNER DOME REFLECTOR	SPUN ALUMINUM 0.080"	1	
7	DOM-PST30-40W-9-9AB3-RD-DIM-MSFS-SPUN DOOR	SPUN ALUMINUM 0.080"	1	
8	DOM-PST30-40W-9-9AB3-RD-DIM-MSFS-POST-SPUN REFLECTOR	SPUN ALUMINUM 0.080"	1	
9	DOM-PST30-40W-9-9AB3-RD-DIM-MSFS-ROUND ALUMINUM BAR	3/4" ALUMINUM ROUND TUBE	4	
10	DOM-PST30"-40W-9-9-8AB3-AL-RD-FRAME LONG ROUND TUBE	3/4" ALUMINUM ROUND TUBE	4	
11	DOM-PST30"-40W-9-9-8AB3-AL-RD-FRAME ROUND BAR	1/2" ALUMINUM ROUND BAR	4	
12	DOM-PST30-40W-9-9AB3-RD-DIM-MSFS-DRIVER BRACKET	ALUMINUM 0.0635"	1	
13	DOM-PST30-40W-9-9AB3-RD-DIM-MSFS-BRACKET PLATE	ALUMINUM 0.250" PLATE	2	
14	DOM-PST30-40W-9-9AB3-RD-DIM-MSFS-BOTTOM BACKET	ALUMINUM 0.250" PLATE	1	
15	DOM-PST30-40W-9-9AB3-RD-DIM-MSFS-LED PLATE	ALUMINUM 0.250" PLATE	1	
16	DOM-PST30-40W-9-9AB3-RD-DIM-MSFS-SPUN CONE COVER	ALUMINUM 0.250" PLATE	1	
17	DOM-PST30-40W-9-9AB3-RD-DIM-MSFS-1.5" CYLINDER	1-1/2" ALUMINUM TUBE POST	1	
18	DOM-PST30-40W-9-9AB3-RD-DIM-MSFS-ACRYLIC	ACRYLIC	1	
19	KTLD-25-UV-700-VDIM-LA1	DRIVER	2	
20	AltaILED_PCN_D1500_110B-10 WATT	LED	4	

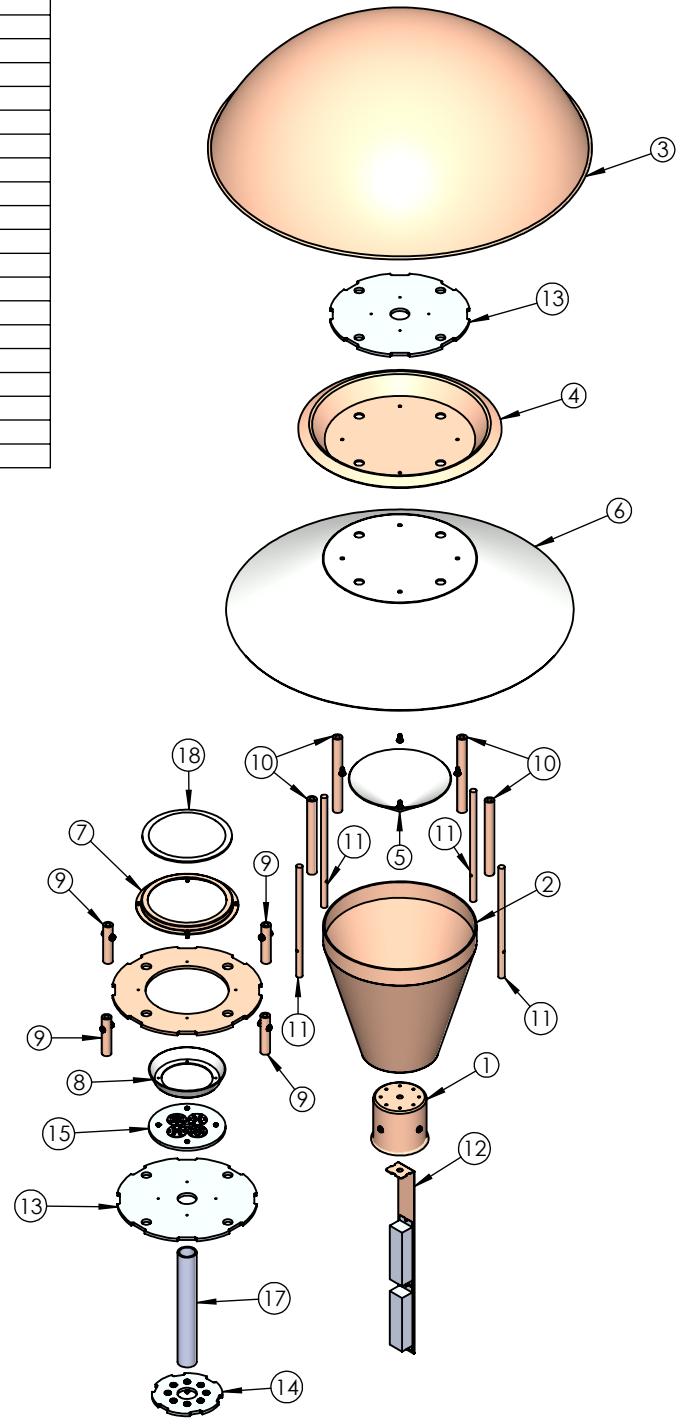

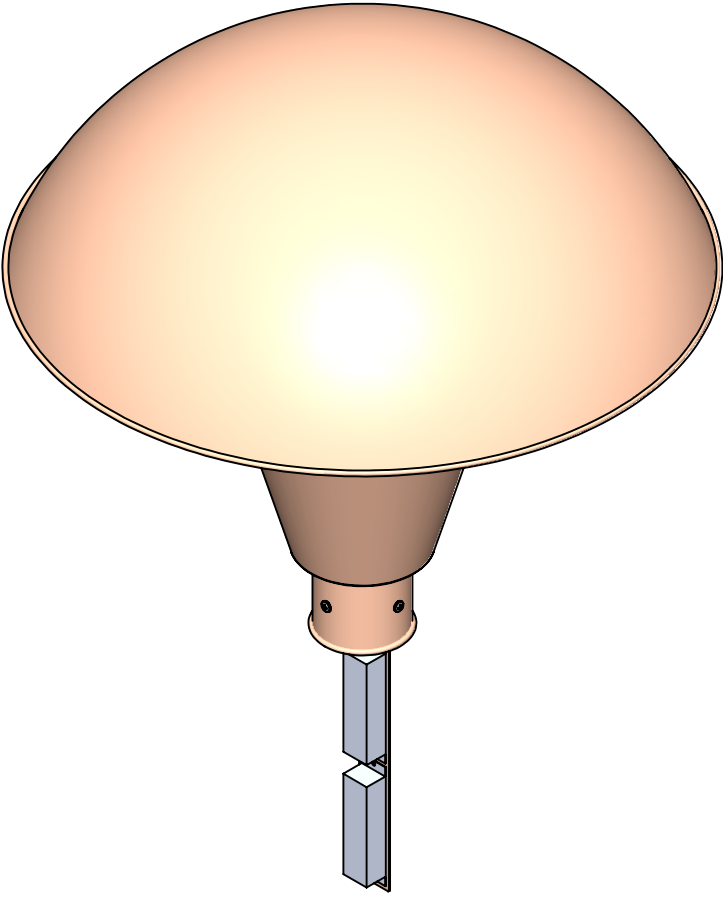
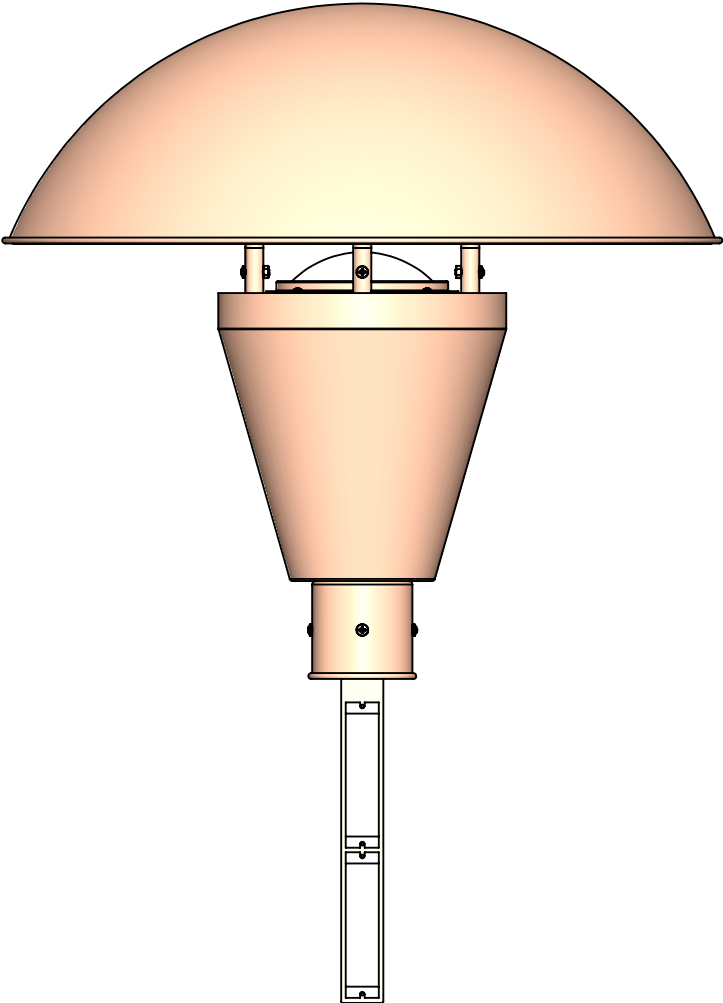
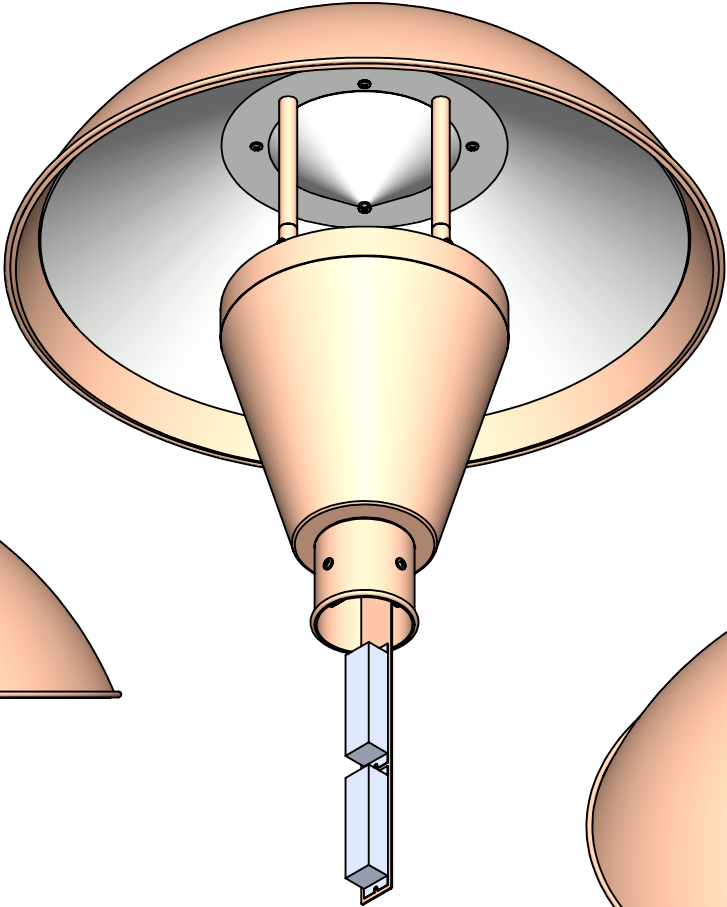

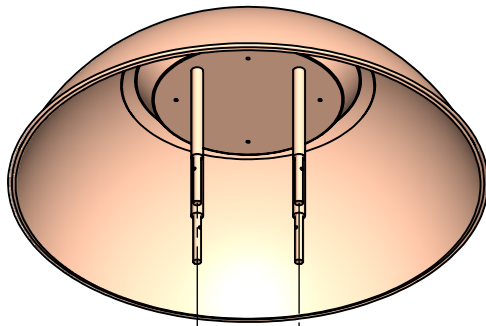

**BOLTED TOGETHER**

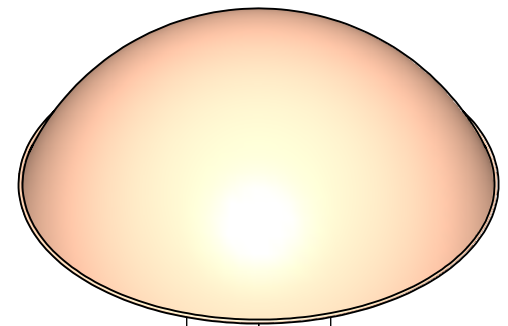
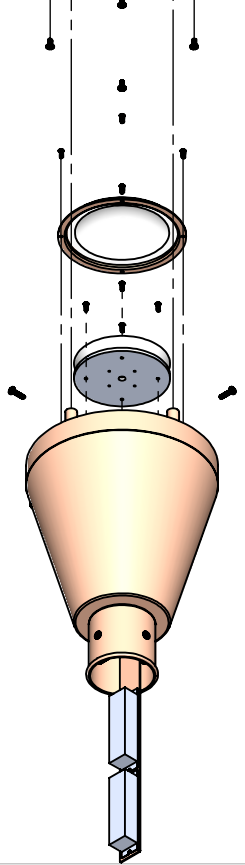
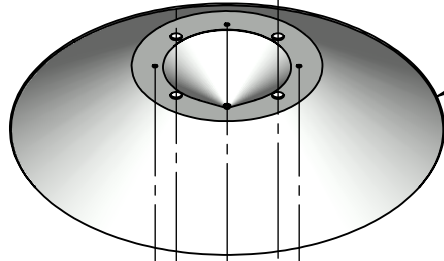

**DOOR WITH DOME LENS**

SPUN REFLECTOR AND  
HEAT SINK PLATE BOLTED TOGETHER  
INTO THE FRAME BODY

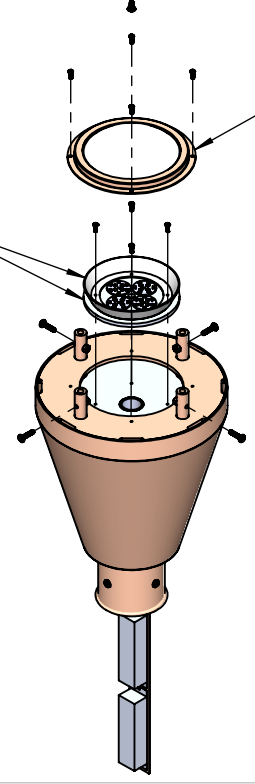
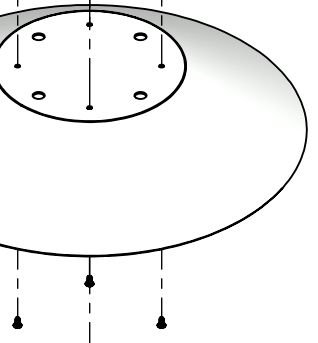

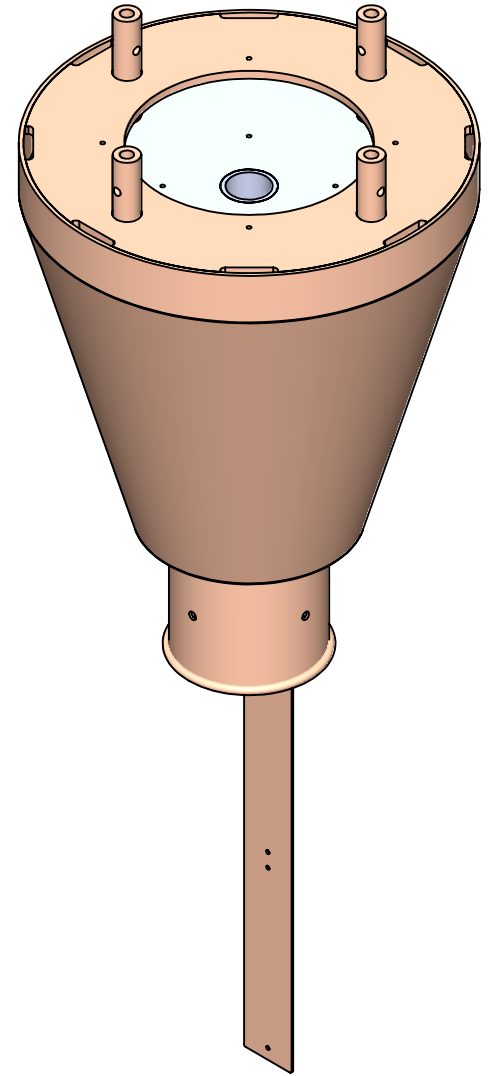
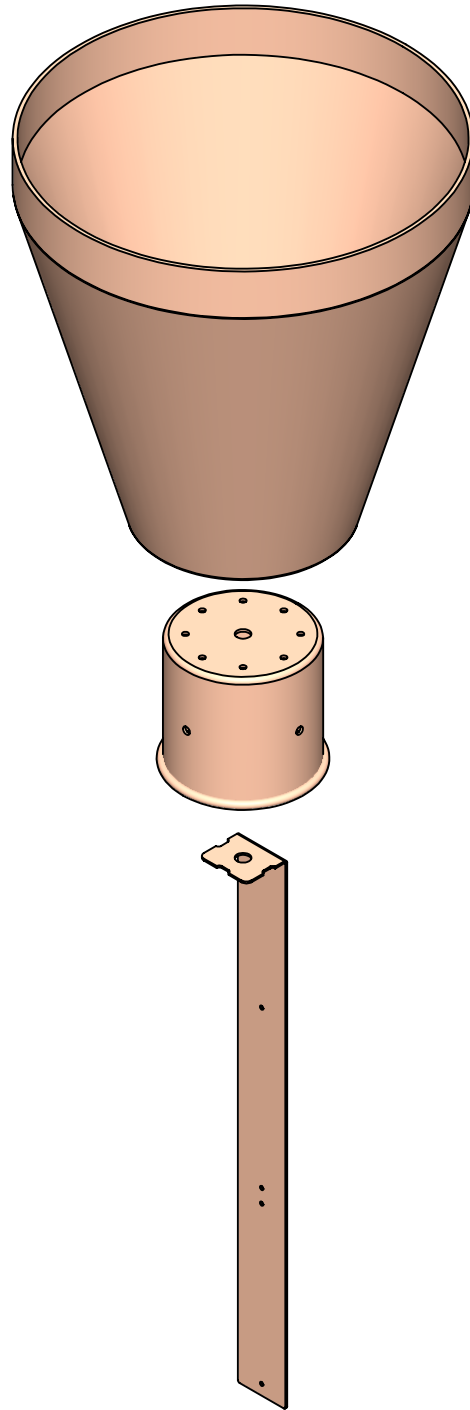
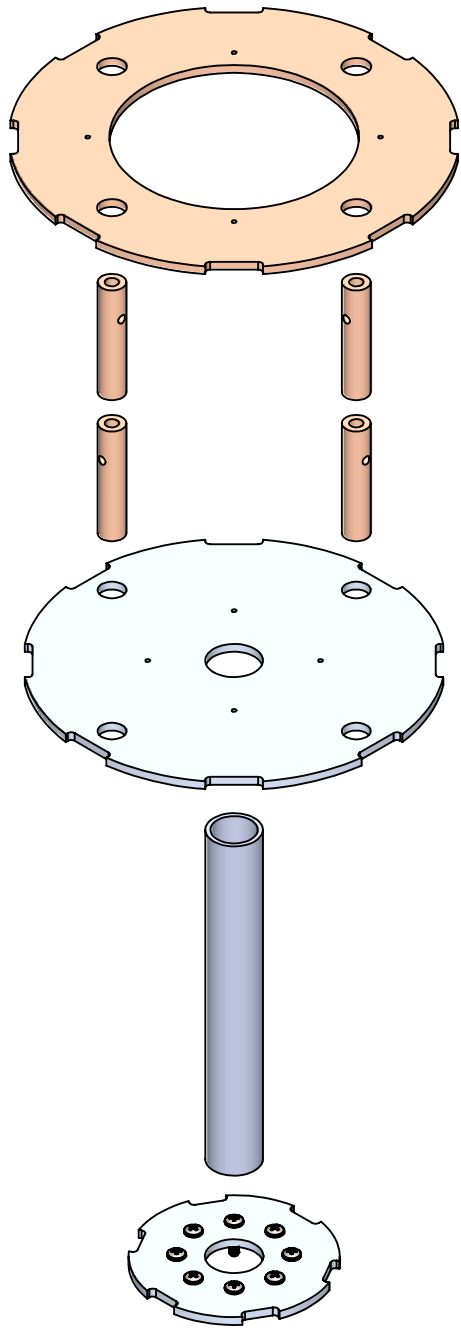

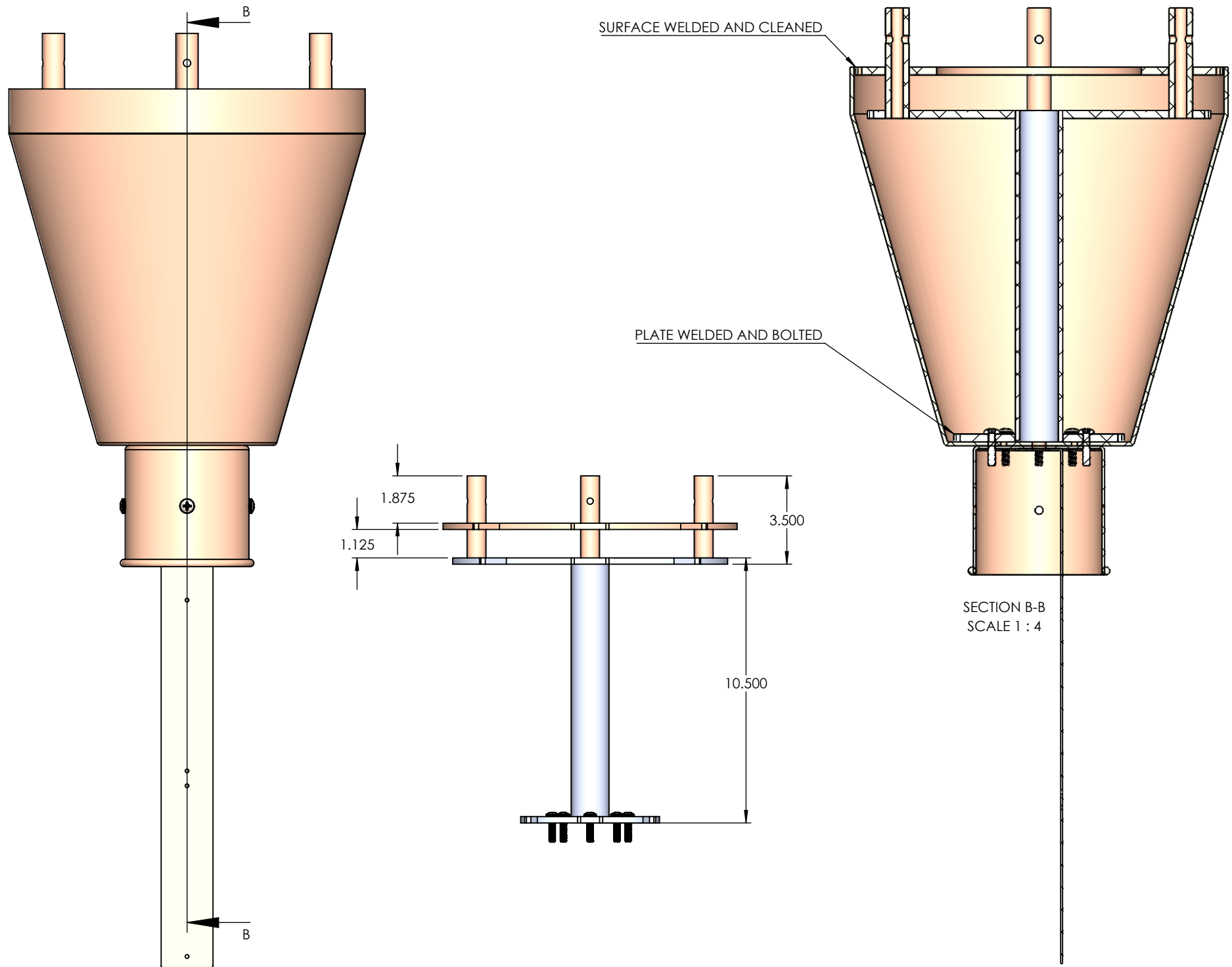

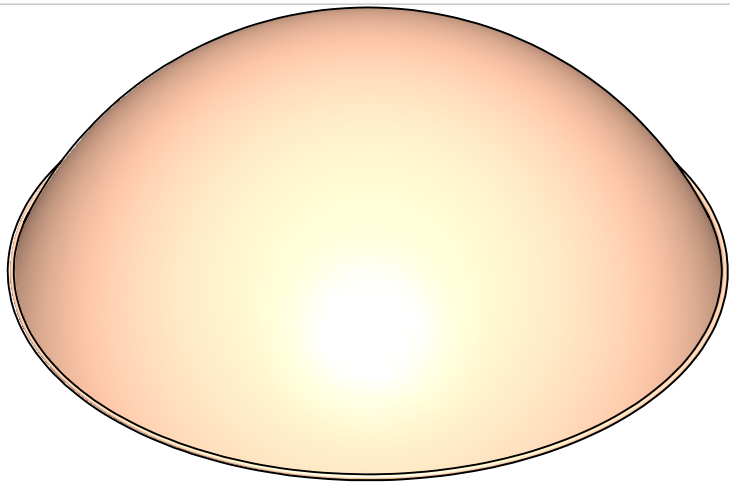

SPUN BOWL AND SPUN SHADE  
WELDED ALL AROUND AND CLEANED,  
USE LIP AND DRILL HOLES TO WELD  
SPINNINGS TOGETHER

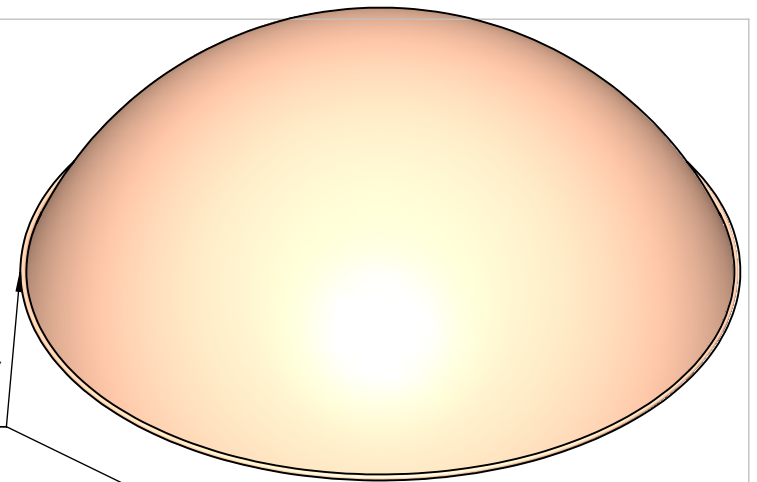

PLATE, ROUND TUBE/BAR AND  
SPUN BOWL WELDED FOR STRENGTH

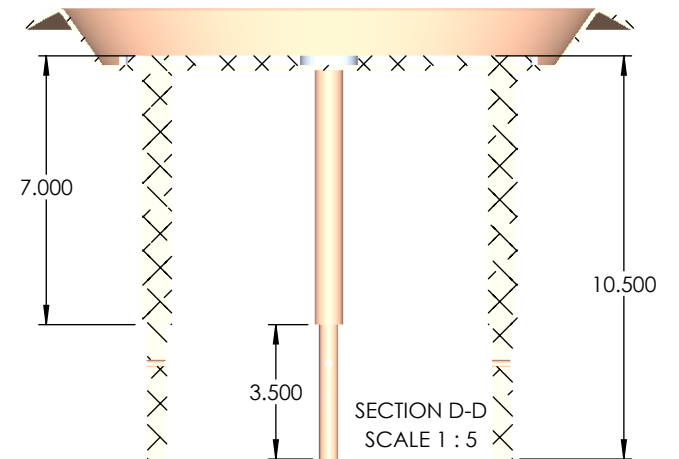
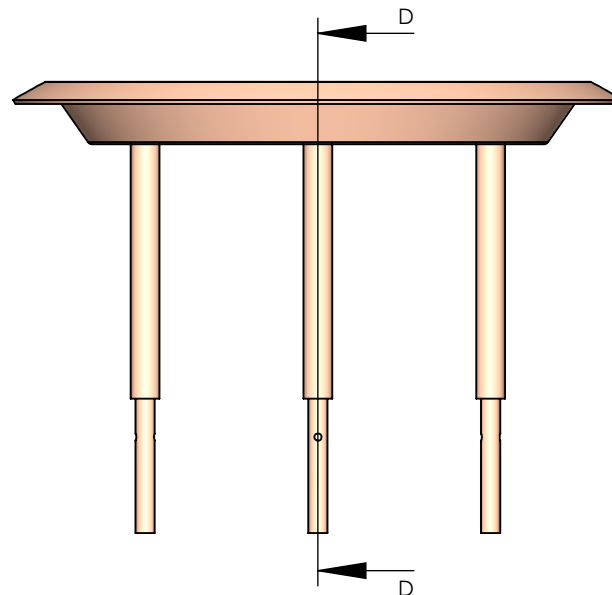
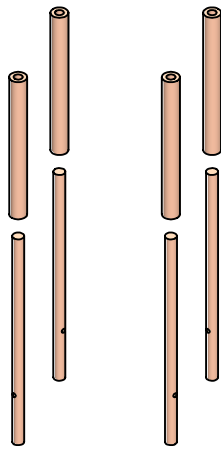
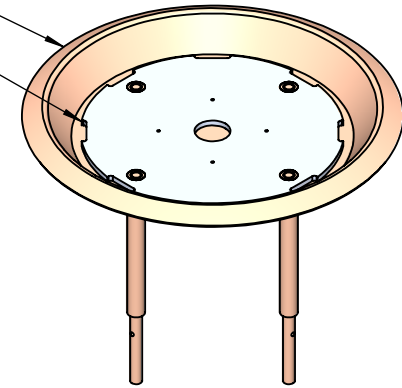
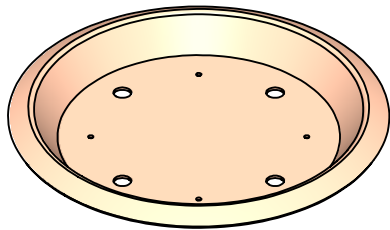
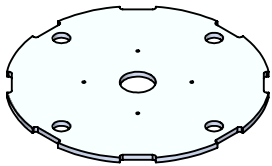

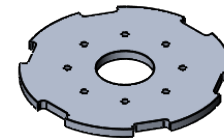
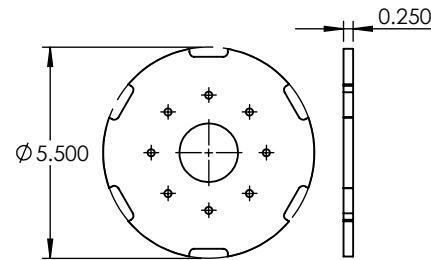
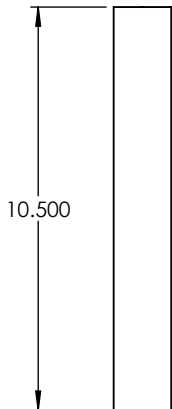
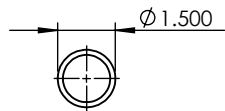
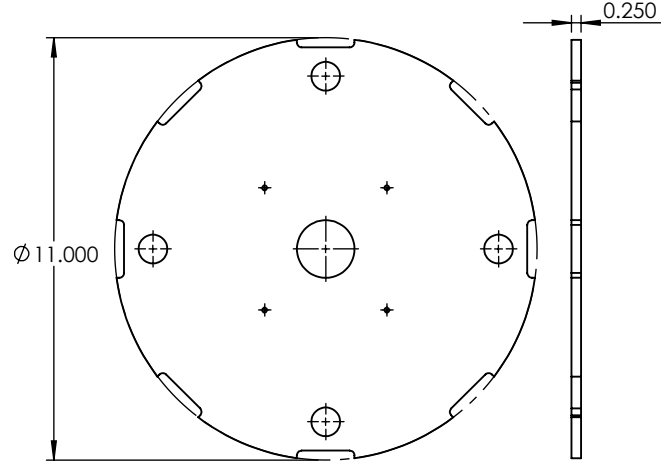
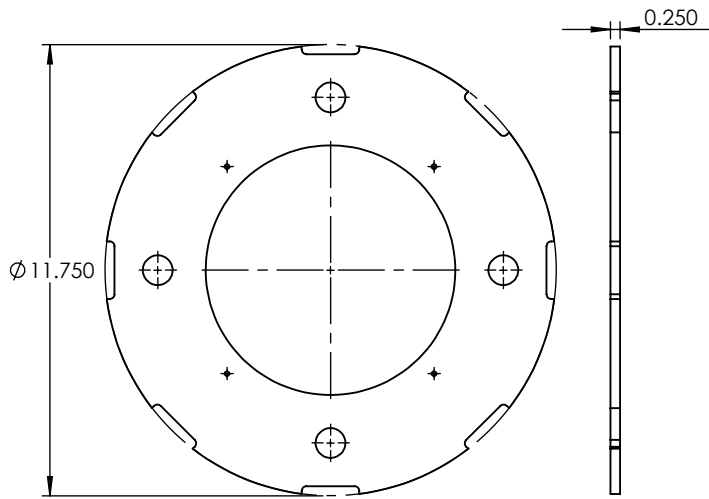
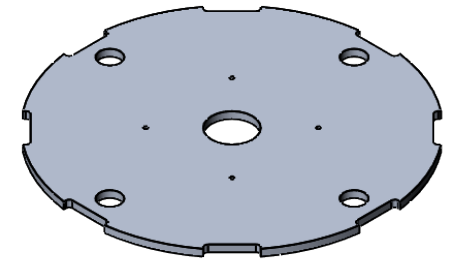
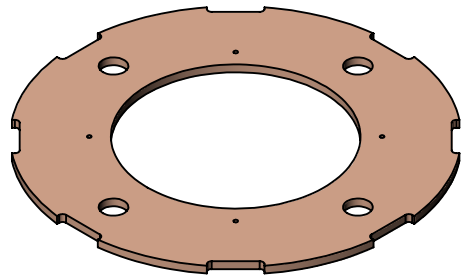

**PROPRIETARY AND CONFIDENTIAL**  
 THE INFORMATION CONTAINED IN THIS DRAWING IS THE SOLE PROPERTY OF <INSERT COMPANY NAME HERE>. ANY REPRODUCTION IN PART OR AS A WHOLE WITHOUT THE WRITTEN PERMISSION OF <INSERT COMPANY NAME HERE> IS PROHIBITED.

		UNLESS OTHERWISE SPECIFIED:	NAME	DATE	1-1/2" ALUMINUM TUBE POST
		DIMENSIONS ARE IN INCHES TOLERANCES: FRACTIONAL ± ANGULAR: MACH ± BEND ± TWO PLACE DECIMAL ± THREE PLACE DECIMAL ±	DRAWN		
		INTERPRET GEOMETRIC TOLERANCING PER:	CHECKED		DOM-PST30-40W-9-9AB3-RD-DIM-MSFS-ASSEMB
		MATERIAL	ENG APPR.		
		FINISH	MFG APPR.		SIZE
NEXT ASSY	USED ON		Q.A.		DWG. NO.
APPLICATION		DO NOT SCALE DRAWING	COMMENTS:		REV
					SCALE: 1:5
					WEIGHT:
					SHEET 8 OF 15

5

4

3

2

1



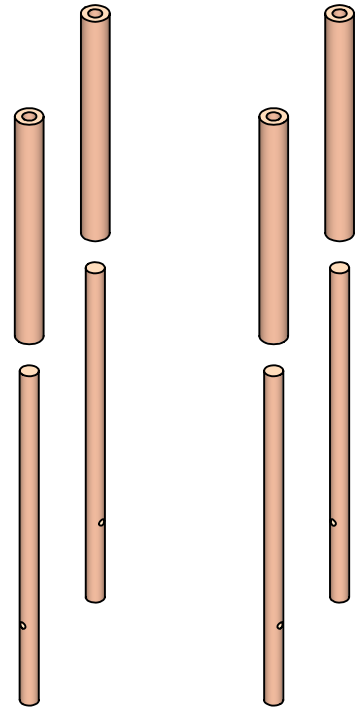
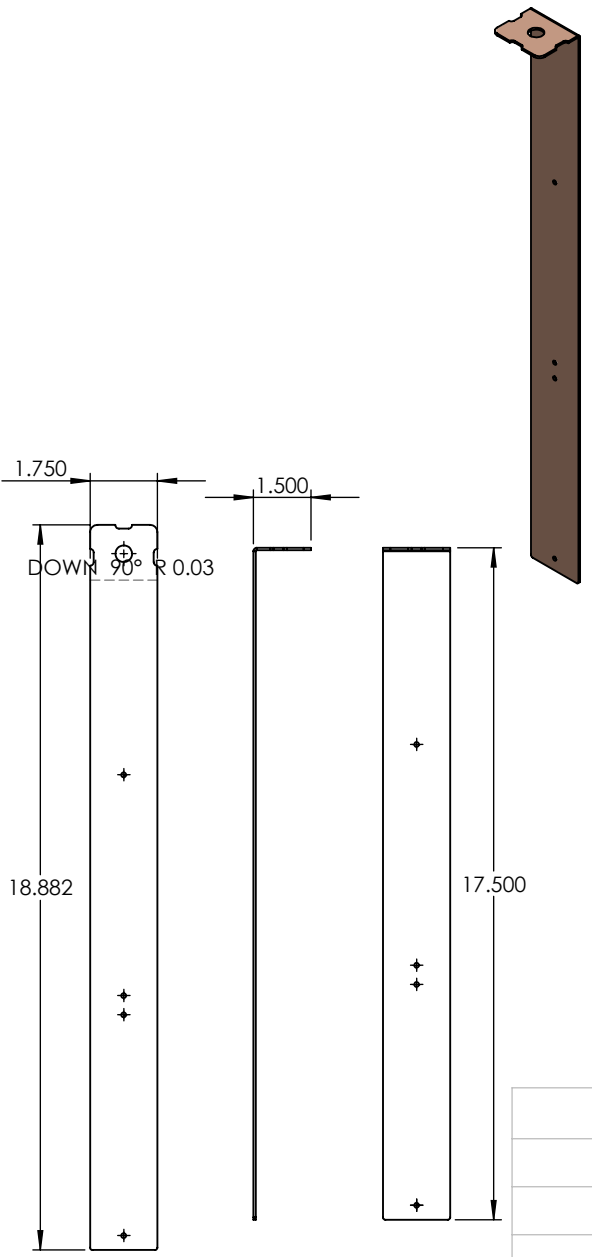

4 STEM ASSEMBLIES

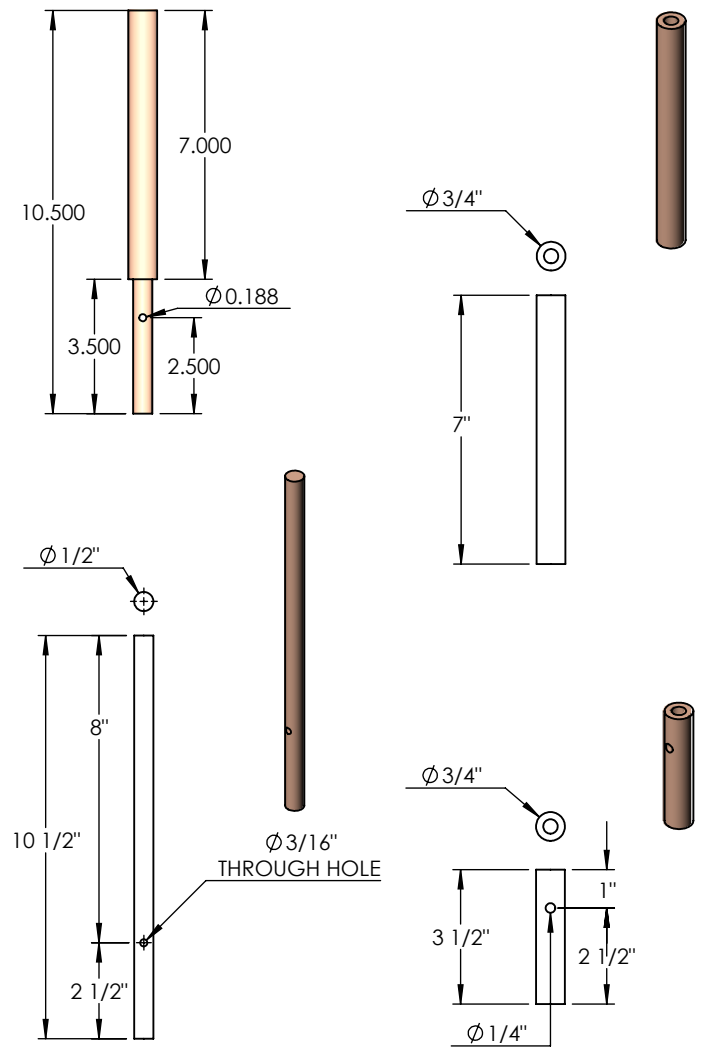

**PROPRIETARY AND CONFIDENTIAL**  
THE INFORMATION CONTAINED IN THIS DRAWING IS THE SOLE PROPERTY OF <INSERT COMPANY NAME HERE>. ANY REPRODUCTION IN PART OR AS A WHOLE WITHOUT THE WRITTEN PERMISSION OF <INSERT COMPANY NAME HERE> IS PROHIBITED.

		UNLESS OTHERWISE SPECIFIED:	NAME	DATE
		DIMENSIONS ARE IN INCHES TOLERANCES: FRACTIONAL ± ANGULAR: MACH ± BEND ± TWO PLACE DECIMAL ± THREE PLACE DECIMAL ±	DRAWN	
		INTERPRET GEOMETRIC TOLERANCING PER:	CHECKED	
		MATERIAL	ENG APPR.	
		FINISH	MFG APPR.	
NEXT ASSY	USED ON		Q.A.	
APPLICATION	DO NOT SCALE DRAWING		COMMENTS:	

1/2" ALUMINUM ROUND BAR

TITLE:

DOM-PST30-40W-9-9AB3-RD-DIM-MSFS-ASSEMB

SIZE	DWG. NO.	REV
<b>A</b>		

SCALE: 1:5	WEIGHT:	SHEET 9 OF 15
------------	---------	---------------

5

4

3

2

1

ITEM NO.	PART NUMBER	DESCRIPTION	QTY.
1	DOM-PST30-40W-9-9AB3-RD-DIM-MSFS-POST-SPUN REFLECTOR	SPUN ALUMINUM 0.080"	1

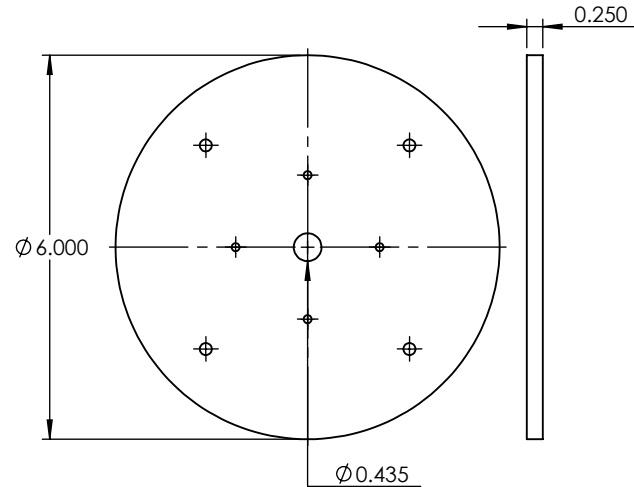
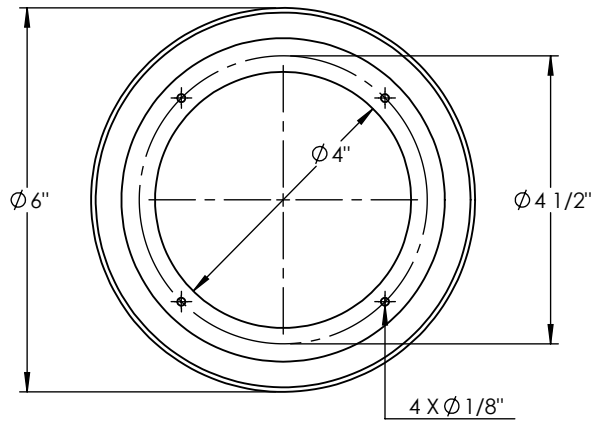
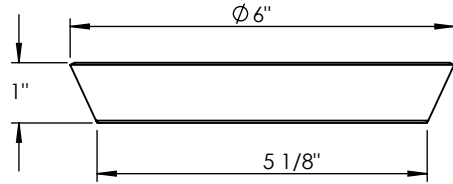
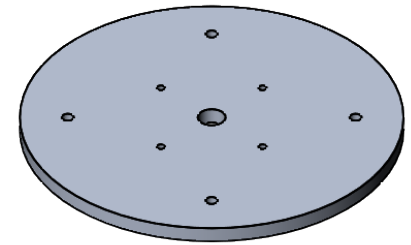
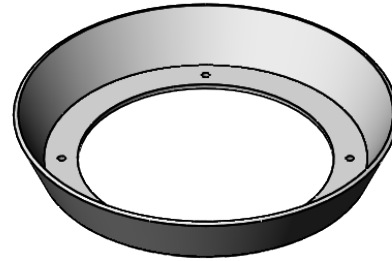

**PROPRIETARY AND CONFIDENTIAL**  
 THE INFORMATION CONTAINED IN THIS DRAWING IS THE SOLE PROPERTY OF <INSERT COMPANY NAME HERE>. ANY REPRODUCTION IN PART OR AS A WHOLE WITHOUT THE WRITTEN PERMISSION OF <INSERT COMPANY NAME HERE> IS PROHIBITED.

		UNLESS OTHERWISE SPECIFIED:	NAME	DATE	SPUN ALUMINUM 0.080"	
		DIMENSIONS ARE IN INCHES	DRAWN		TITLE:	
		TOLERANCES:	CHECKED		DOM-PST30-40W-9-9AB3-RD-DIM-MSFS-ASSEMB	
		FRACTIONAL ±	ENG APPR.		SIZE DWG. NO. REV	
		ANGULAR: MACH ± BEND ±	MFG APPR.		SCALE: 1:3 WEIGHT: SHEET 10 OF 15	
		TWO PLACE DECIMAL ±	Q.A.			
		THREE PLACE DECIMAL ±	COMMENTS:			
		INTERPRET GEOMETRIC TOLERANCING PER:				
		MATERIAL				
NEXT ASSY	USED ON	FINISH				
APPLICATION		DO NOT SCALE DRAWING				

5

4

3

2

1

ITEM NO.	PART NUMBER	DESCRIPTION	QTY.
1	DOM-PST30-40W-9-9AB3-RD-DIM-MSFS-SPUN CONE	SPUN ALUMINUM 0.125"	1

ITEM NO.	PART NUMBER	DESCRIPTION	QTY.
1	DOM-PST30-40W-9-9AB3-RD-DIM-MSFS-POST-CUSTOM FITTER	POST FITTER	1

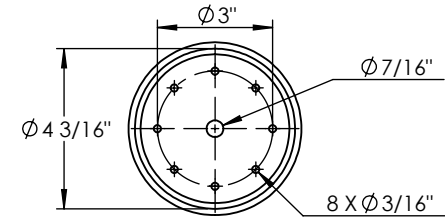
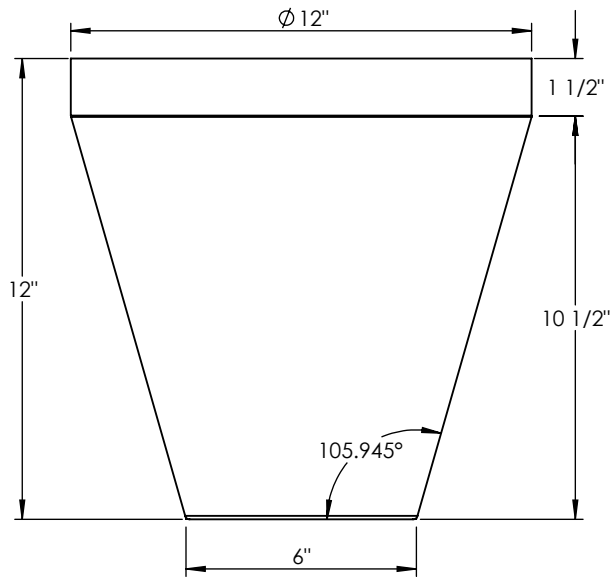
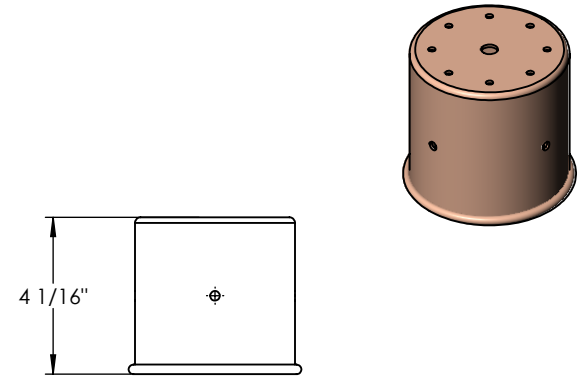
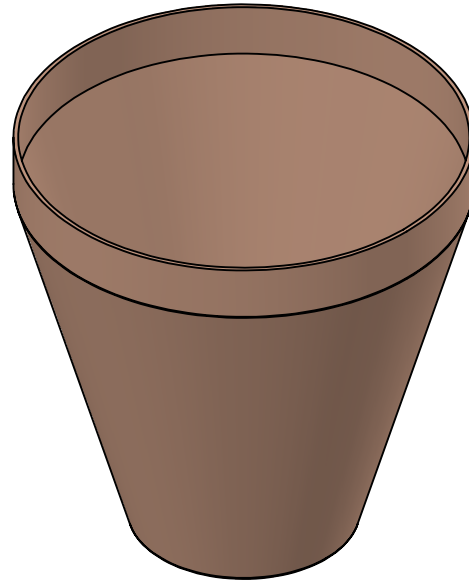
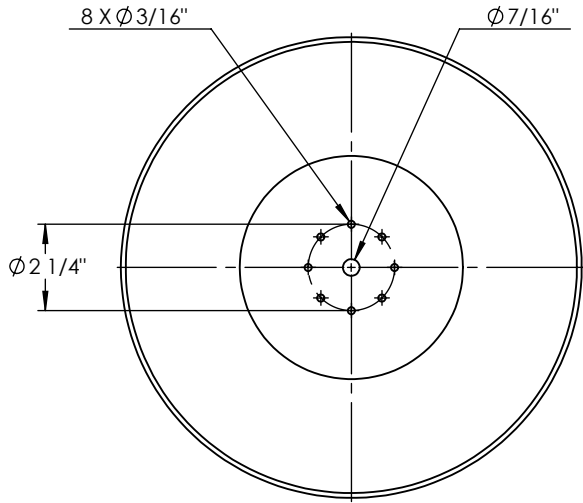

UNLESS OTHERWISE SPECIFIED:		NAME	DATE	SPUN ALUMINUM 0.125"	
DIMENSIONS ARE IN INCHES		DRAWN		TITLE:	
TOLERANCES:		CHECKED		DOM-PST30-40W-9-9AB3-RD-DIM-MSFS-ASSEMBLY	
FRACTIONAL ±		ENG APPR.		SIZE	
ANGULAR: MACH ± BEND ±		MFG APPR.		DWG. NO.	
TWO PLACE DECIMAL ±		Q.A.		REV	
THREE PLACE DECIMAL ±		COMMENTS:		SCALE: 1:5	
INTERPRET GEOMETRIC TOLERANCING PER:				WEIGHT:	
MATERIAL				SHEET 11 OF 15	
FINISH					
NEXT ASSY					
USED ON					
APPLICATION					
DO NOT SCALE DRAWING					

**PROPRIETARY AND CONFIDENTIAL**  
 THE INFORMATION CONTAINED IN THIS DRAWING IS THE SOLE PROPERTY OF <INSERT COMPANY NAME HERE>. ANY REPRODUCTION IN PART OR AS A WHOLE WITHOUT THE WRITTEN PERMISSION OF <INSERT COMPANY NAME HERE> IS PROHIBITED.

ITEM NO.	PART NUMBER	DESCRIPTION	QTY.
1	DOM-PST30-40W-9-9AB3-RD-DIM-MSFS-SPUN DOOR	SPUN ALUMINUM 0.080"	1

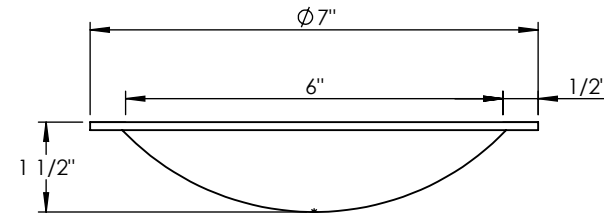
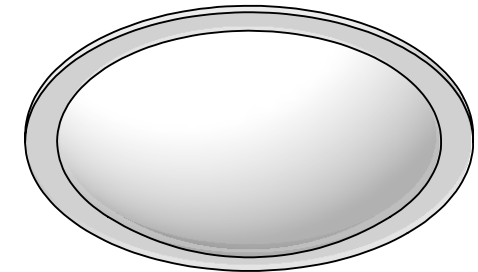
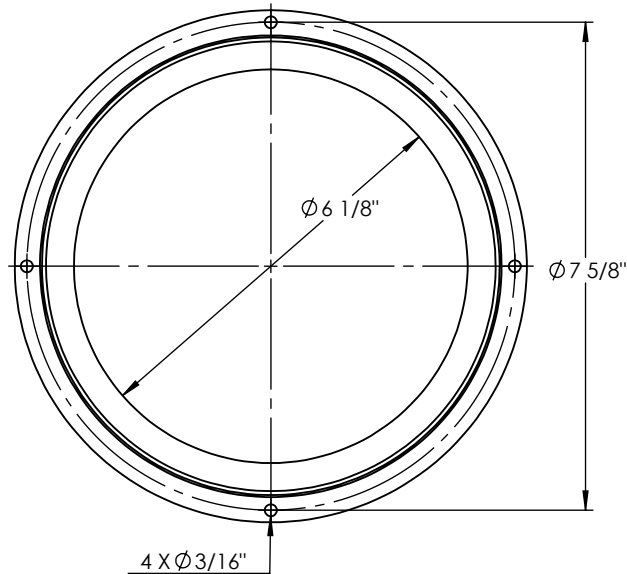
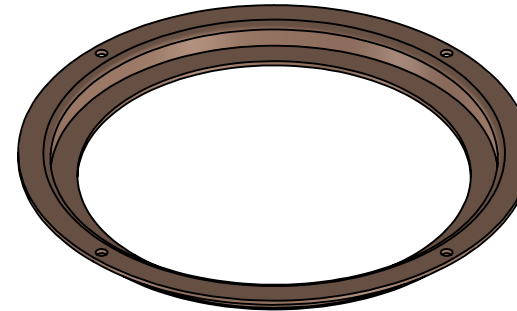
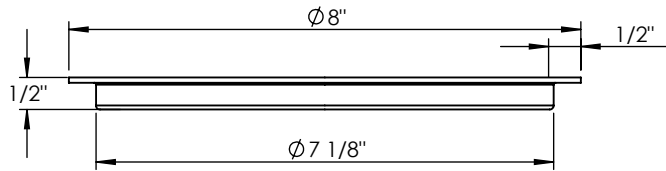

**PROPRIETARY AND CONFIDENTIAL**  
 THE INFORMATION CONTAINED IN THIS DRAWING IS THE SOLE PROPERTY OF <INSERT COMPANY NAME HERE>. ANY REPRODUCTION IN PART OR AS A WHOLE WITHOUT THE WRITTEN PERMISSION OF <INSERT COMPANY NAME HERE> IS PROHIBITED.

		UNLESS OTHERWISE SPECIFIED:	NAME	DATE	SPUN ALUMINUM 0.080"	
		DIMENSIONS ARE IN INCHES	DRAWN		TITLE:	
		TOLERANCES:	CHECKED		DOM-PST30-40W-9-9AB3-RD-DIM-MSFS-ASSEMB	
		FRACTIONAL ±	ENG APPR.		SIZE DWG. NO. REV	
		ANGULAR: MACH ± BEND ±	MFG APPR.		A	
		TWO PLACE DECIMAL ±	Q.A.		SCALE: 1:3 WEIGHT: SHEET 12 OF 15	
		THREE PLACE DECIMAL ±	COMMENTS:			
		INTERPRET GEOMETRIC TOLERANCING PER:				
		MATERIAL				
NEXT ASSY	USED ON	FINISH				
APPLICATION		DO NOT SCALE DRAWING				

ITEM NO.	PART NUMBER	DESCRIPTION	QTY.
1	DOM-PST30-40W-9-9AB3-RD-DIM-MSFS-POST- INNER DOME REFLECTOR	SPUN ALUMINUM 0.080"	1

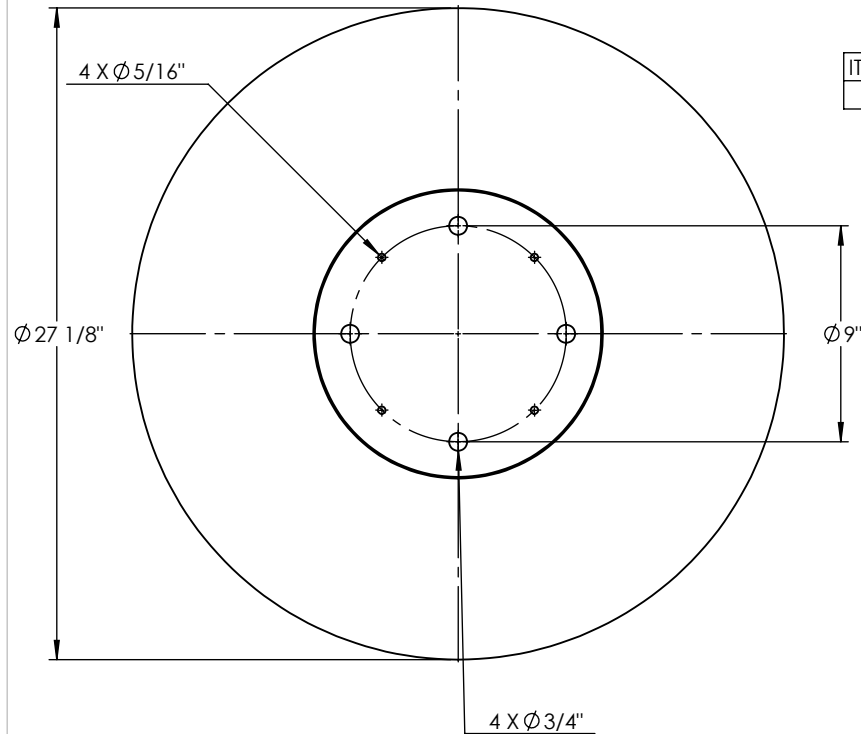
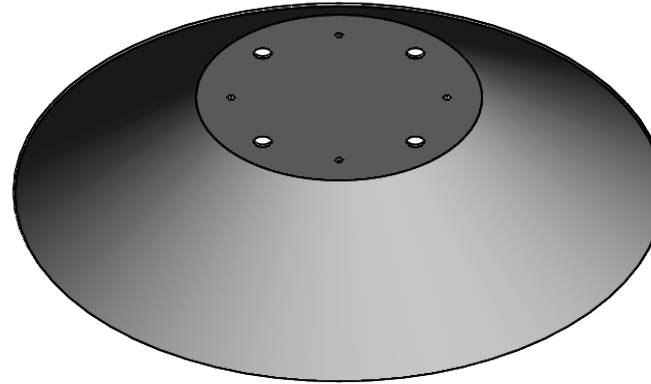
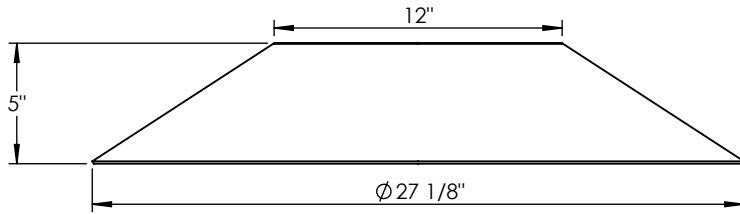

ITEM NO.	PART NUMBER	DESCRIPTION	QTY.
1	DOM-PST30-40W-9-9AB3-RD-DIM-MSFS-POST-DOME REFLECTOR CONE	SPUN ALUMINUM 0.080"	1

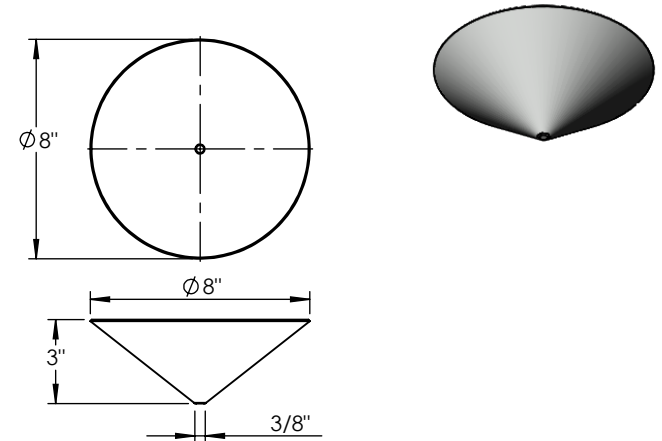

UNLESS OTHERWISE SPECIFIED:		NAME	DATE	SPUN ALUMINUM 0.080"	
DIMENSIONS ARE IN INCHES		DRAWN		TITLE:	
TOLERANCES:		CHECKED		DOM-PST30-40W-9-9AB3-RD-DIM-MSFS-ASSEMB	
FRACTIONAL ±		ENG APPR.		SIZE	
ANGULAR: MACH ± BEND ±		MFG APPR.		DWG. NO.	
TWO PLACE DECIMAL ±		Q.A.		REV	
THREE PLACE DECIMAL ±		COMMENTS:		SCALE: 1:8	
INTERPRET GEOMETRIC TOLERANCING PER:				WEIGHT:	
MATERIAL				SHEET 13 OF 15	
FINISH					
APPLICATION					
DO NOT SCALE DRAWING					

**PROPRIETARY AND CONFIDENTIAL**  
 THE INFORMATION CONTAINED IN THIS DRAWING IS THE SOLE PROPERTY OF <INSERT COMPANY NAME HERE>. ANY REPRODUCTION IN PART OR AS A WHOLE WITHOUT THE WRITTEN PERMISSION OF <INSERT COMPANY NAME HERE> IS PROHIBITED.

ITEM NO.	PART NUMBER	DESCRIPTION	QTY.
1	DOM-PST30-40W-9-9AB3-RD-DIM-MSFS-SPUN DOME BRACKET	SPUN ALUMINUM 0.125"	1

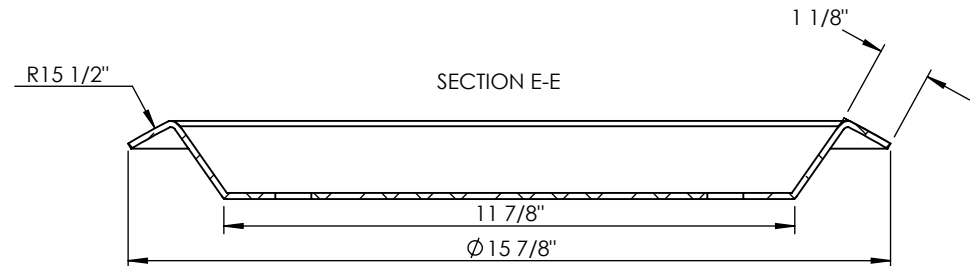
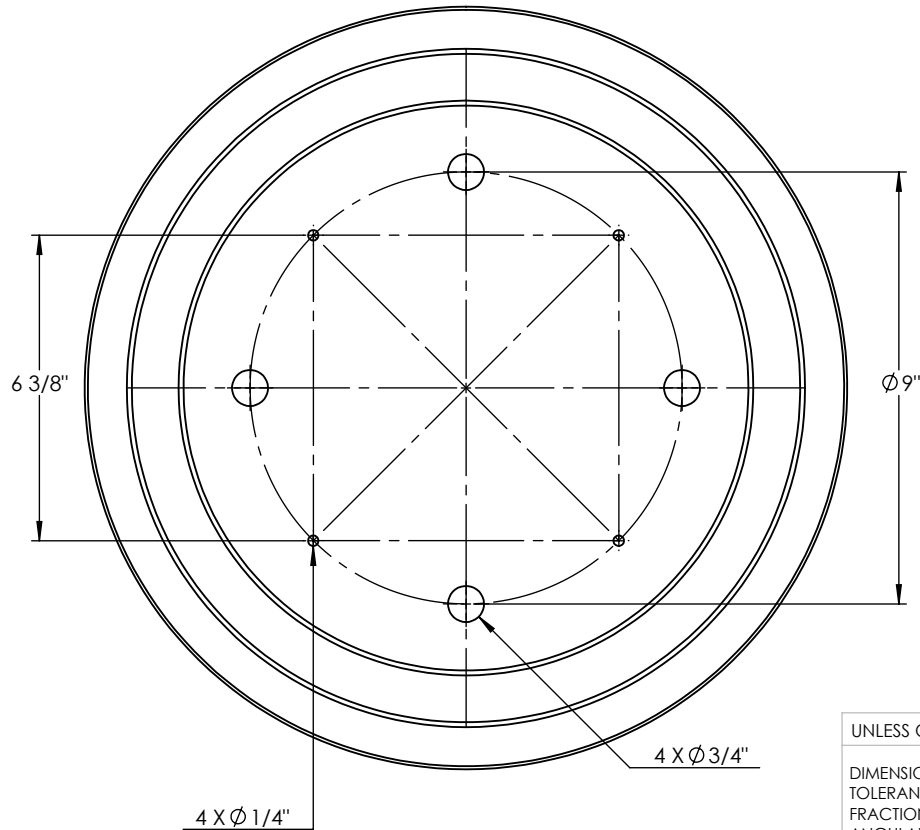
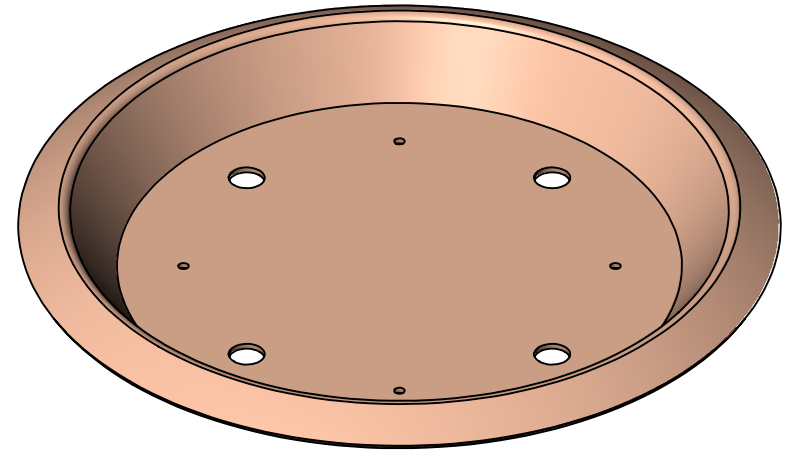
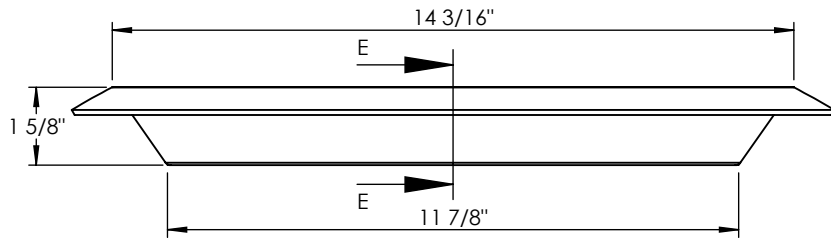

UNLESS OTHERWISE SPECIFIED:		NAME	DATE	SPUN ALUMINUM 0.125"	
DIMENSIONS ARE IN INCHES		DRAWN		TITLE:	
TOLERANCES:		CHECKED		DOM-PST30-40W-9-9AB3-RD-DIM-MSFS-ASSEMBLY	
FRACTIONAL $\pm$		ENG APPR.		SIZE	
ANGULAR: MACH $\pm$ BEND $\pm$		MFG APPR.		DWG. NO.	
TWO PLACE DECIMAL $\pm$		Q.A.		REV	
THREE PLACE DECIMAL $\pm$		COMMENTS:		SCALE: 1:4	
INTERPRET GEOMETRIC TOLERANCING PER:				WEIGHT:	
MATERIAL				SHEET 14 OF 15	
FINISH					
APPLICATION					
DO NOT SCALE DRAWING					

**PROPRIETARY AND CONFIDENTIAL**  
 THE INFORMATION CONTAINED IN THIS DRAWING IS THE SOLE PROPERTY OF <INSERT COMPANY NAME HERE>. ANY REPRODUCTION IN PART OR AS A WHOLE WITHOUT THE WRITTEN PERMISSION OF <INSERT COMPANY NAME HERE> IS PROHIBITED.

NEXT ASSY	USED ON
APPLICATION	

ITEM NO.	PART NUMBER	DESCRIPTION	QTY.
1	DOM-PST30-40W-9-9AB3-RD-DIM-MSFS-POST-DOME REFLECTOR	SPUN ALUMINUM 0.125"	1

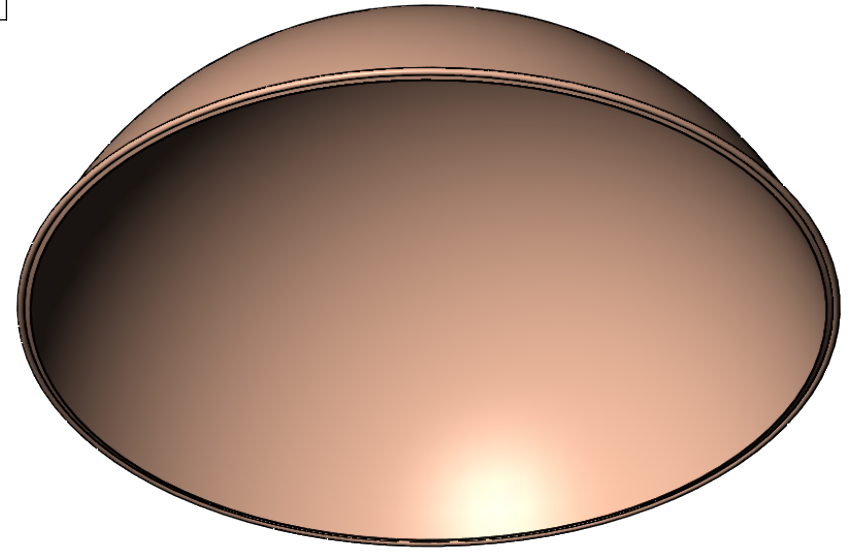
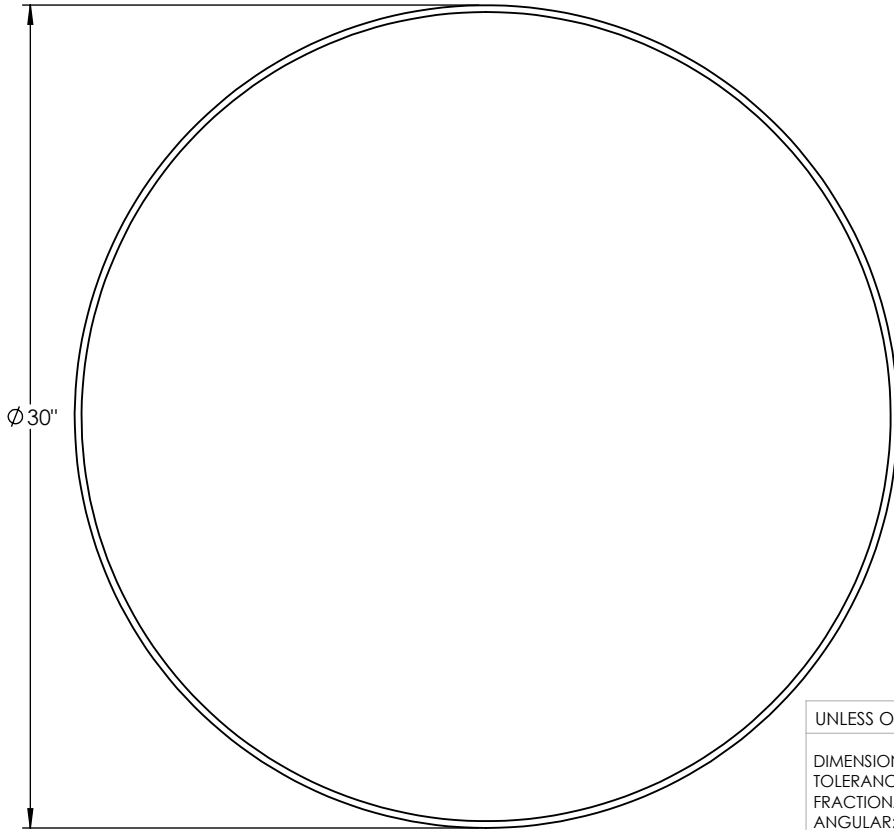
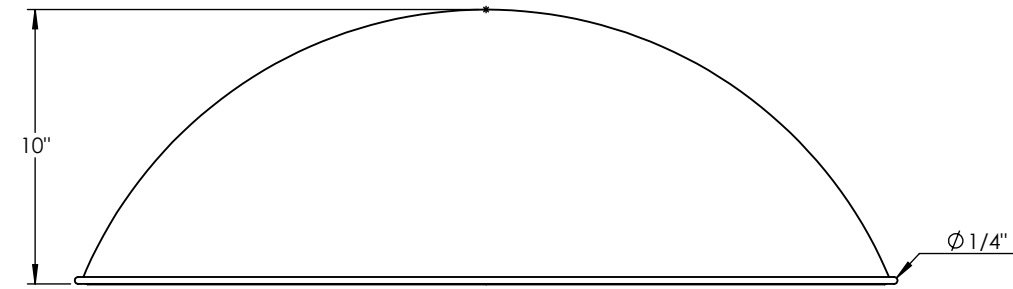

UNLESS OTHERWISE SPECIFIED:		NAME	DATE	SPUN ALUMINUM 0.125"	
DIMENSIONS ARE IN INCHES		DRAWN		TITLE:	
TOLERANCES:		CHECKED		DOM-PST30-40W-9-9AB3-RD-DIM-MSFS-ASSEMB	
FRACTIONAL ±		ENG APPR.		SIZE DWG. NO. REV	
ANGULAR: MACH ± BEND ±		MFG APPR.		SCALE: 1:7 WEIGHT: SHEET 15 OF 15	
TWO PLACE DECIMAL ±		Q.A.			
THREE PLACE DECIMAL ±		COMMENTS:			
INTERPRET GEOMETRIC TOLERANCING PER:					
MATERIAL					
FINISH					
NEXT ASSY	USED ON				
APPLICATION		DO NOT SCALE DRAWING			

**PROPRIETARY AND CONFIDENTIAL**  
 THE INFORMATION CONTAINED IN THIS DRAWING IS THE SOLE PROPERTY OF <INSERT COMPANY NAME HERE>. ANY REPRODUCTION IN PART OR AS A WHOLE WITHOUT THE WRITTEN PERMISSION OF <INSERT COMPANY NAME HERE> IS PROHIBITED.