

ITEM NO.	PART NUMBER	DESCRIPTION	QTY.	CUT
1	DOM-PST30-40W-9-9AB3-RD-DIM-MSFS-POST-4" CYLINDER POST	4" ALUMINUM TUBE	1	
2	DOM-PST30-40W-9-9AB3-RD-DIM-MSFS-30K-HAND COVER	ALUMINUM 0.0635"	1	
3	DOM-PST30-40W-9-9AB3-RD-DIM-MSFS-POST-COVER BRACKET	ALUMINUM 0.0635"	2	
5	DOM-PST30-40W-9-9AB3-RD-DIM-MSFS-POST-ANCHOR PLATE	ALUMINUM 0.500" PLATE	1	
6	DOM-PST30-40W-9-9AB3-RD-DIM-MSFS-POST-ANCHOR COVER	SPUN ALUMINUM 0.080"	2	
7	DOM-PST30-40W-9-9AB3-RD-DIM-MSFS-POST	FIXTURE HEAD	1	
8	ANCHOR ASSEMBLY	ANCHOR BOLT	4	
9	FSP-211	MOTION SENSOR	1	
10	DOM-PST30-40W-9-9AB3-RD-DIM-MSFS-POST-RECEPTICAL FRONT	ALUMINUM PLATE 0.125"	1	
11	DOM-PST30-40W-9-9AB3-RD-DIM-MSFS-POST-RECEPTICAL TOPS	ALUMINUM PLATE 0.125"	1	
12	DOM-PST30-40W-9-9AB3-RD-DIM-MSFS-POST-RECEPTICAL SIDES	ALUMINUM PLATE 0.125"	2	
13	DOM-PST30-40W-9-9AB3-RD-DIM-MSFS-POST-RECEPTICAL BOTTOM	ALUMINUM PLATE 0.125"	1	
14	DOM-PST30-40W-9-9AB3-RD-DIM-MSFS-POST-RECEPTICAL DOOR	ALUMINUM 0.0635"	1	

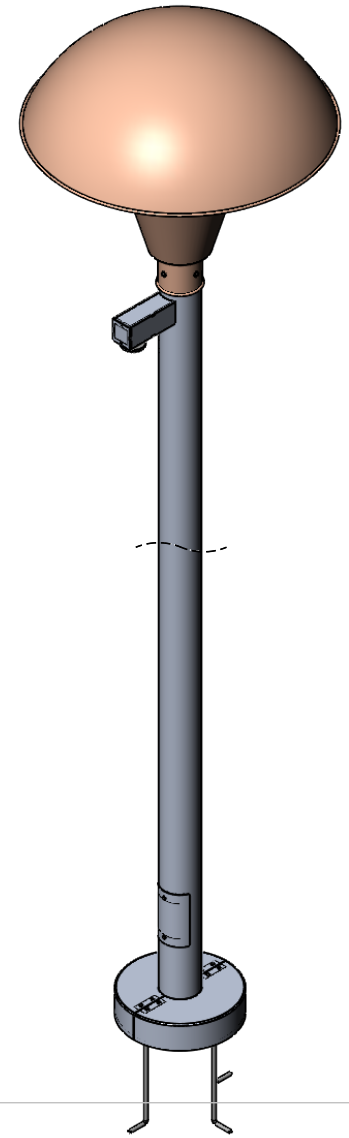
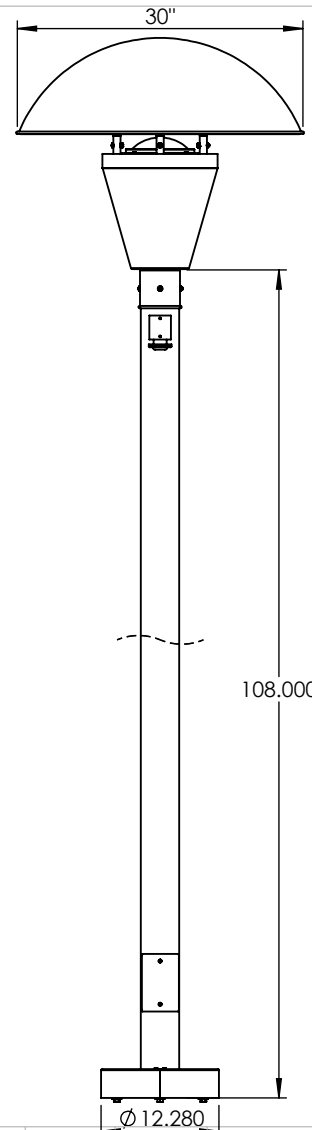
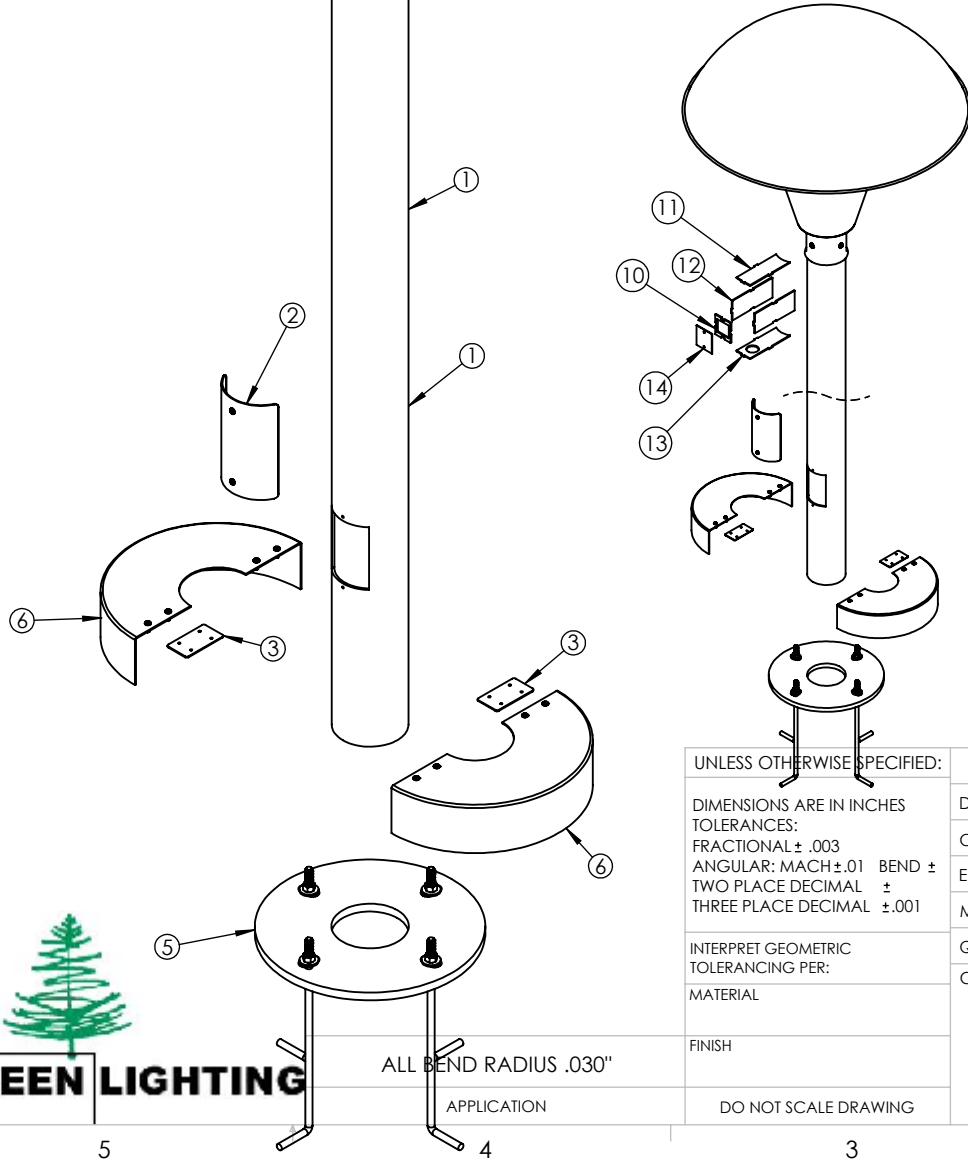

UNLESS OTHERWISE SPECIFIED:  
 DIMENSIONS ARE IN INCHES  
 TOLERANCES:  
 FRACTIONAL ± .003  
 ANGULAR: MACH ± .01 BEND ±  
 TWO PLACE DECIMAL ±  
 THREE PLACE DECIMAL ±.001

INTERPRET GEOMETRIC TOLERANCING PER:  
 MATERIAL  
 FINISH

APPLICATION  
 DO NOT SCALE DRAWING

	NAME	DATE
DRAWN		
CHECKED		
ENG APPR.		
MFG APPR.		
Q.A.		
COMMENTS:		

TITLE:  
 DOM-PST30-40W-9-9AB3-RD-DIM-MSFS

SIZE	DWG. NO.	REV
<b>A</b>	TICKET 25596	
SCALE: 1:20	WEIGHT:	SHEET 1 OF 6



ALL BEND RADIUS .030"

5

4

3

2

1

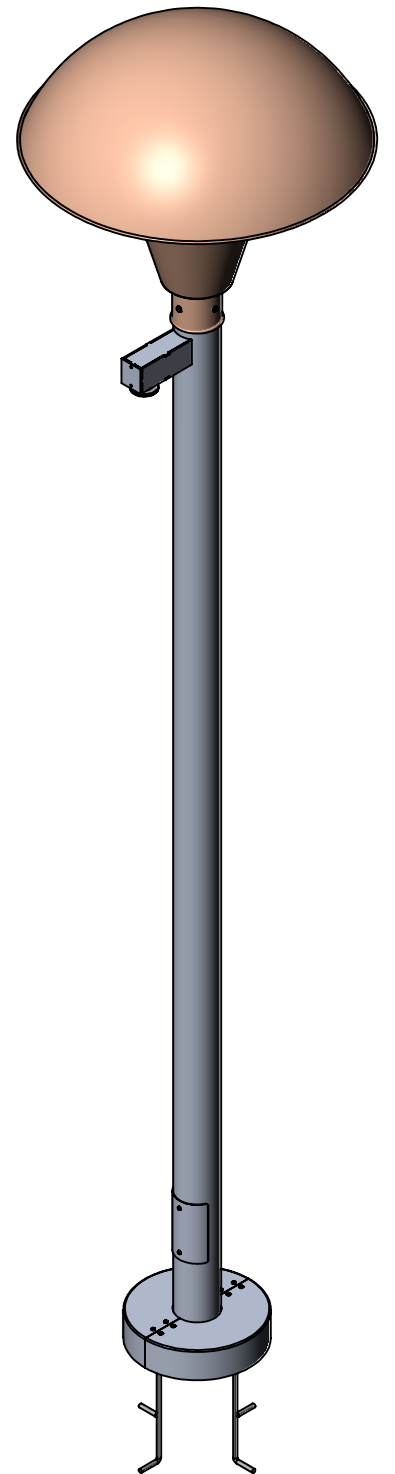
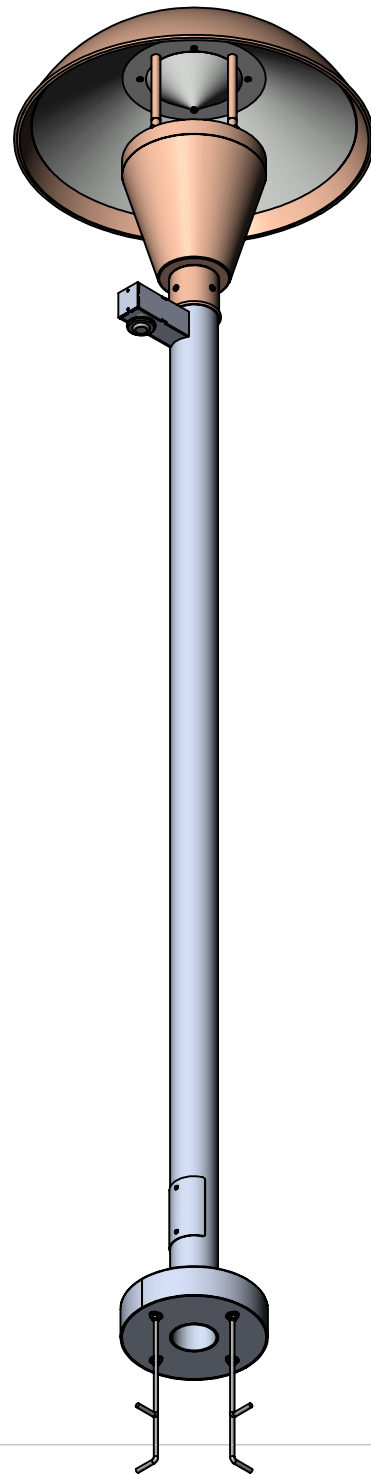
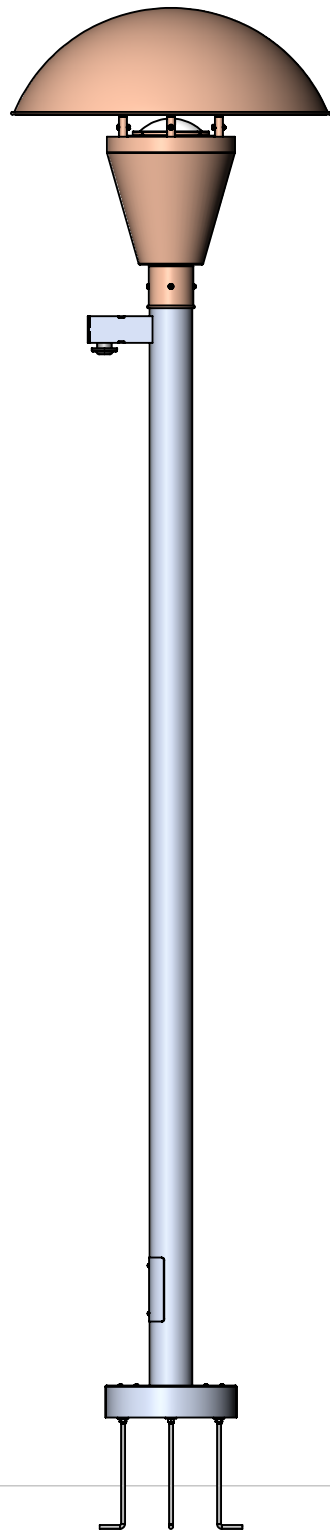
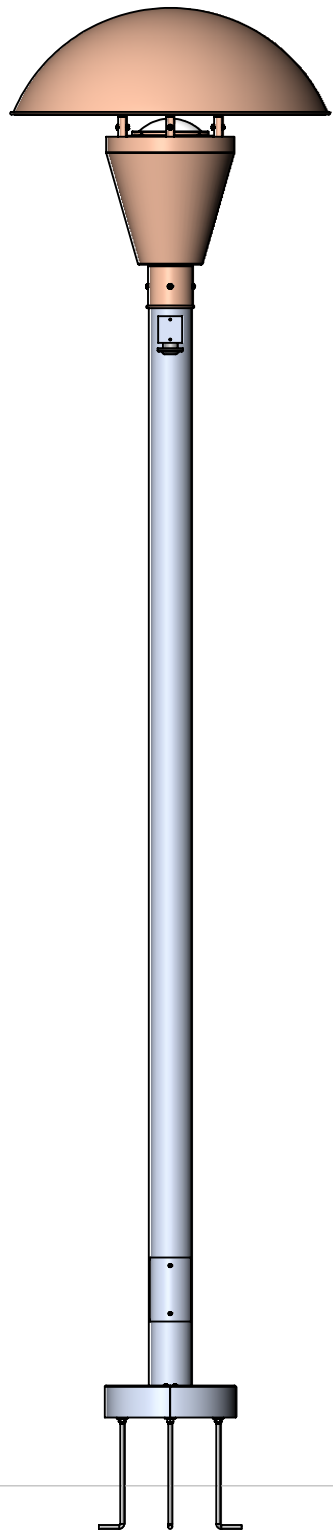

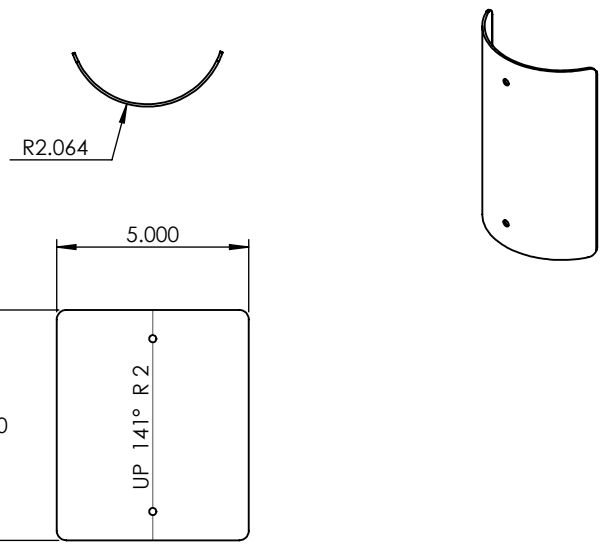
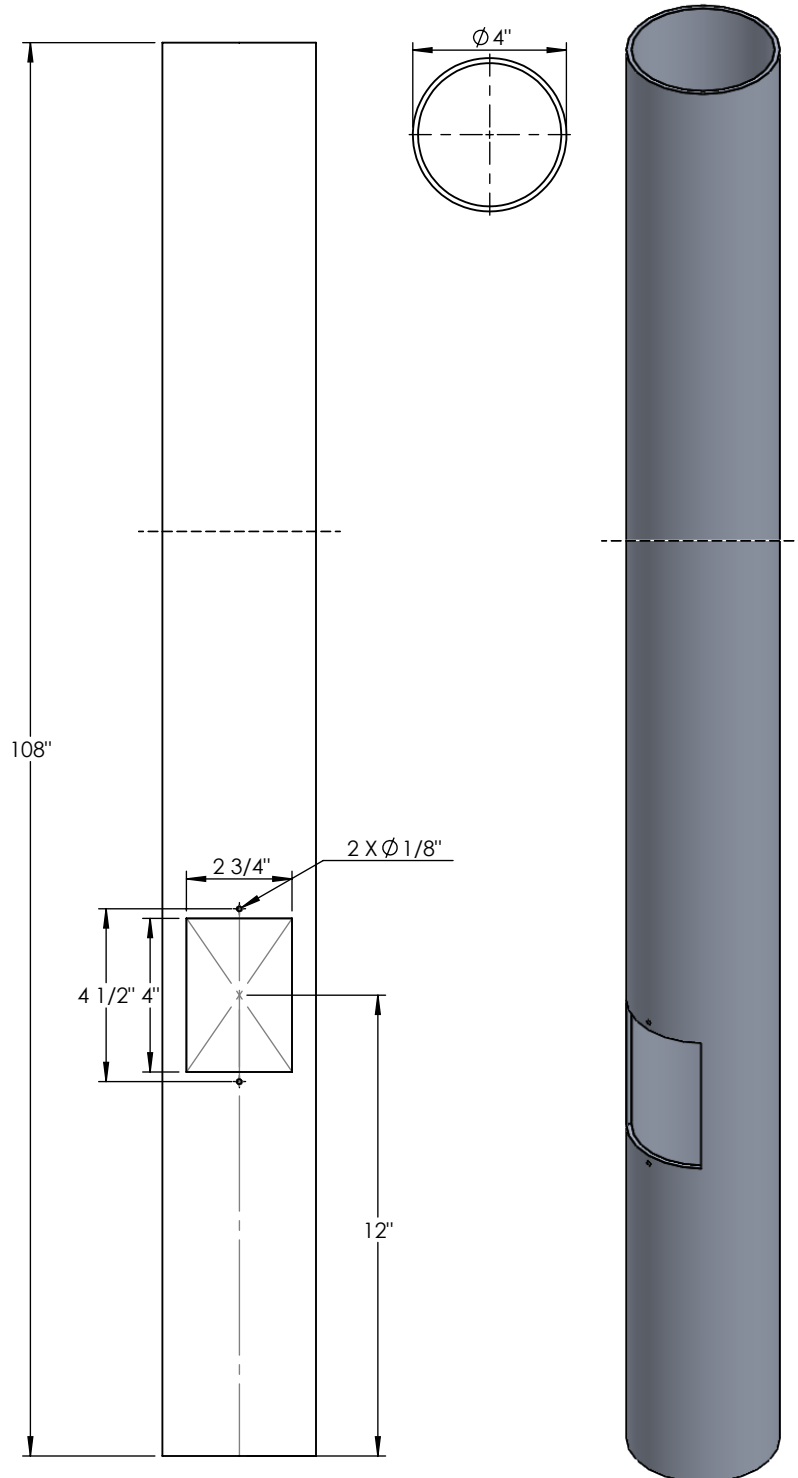

UNLESS OTHERWISE SPECIFIED:		NAME	DATE	4" ALUMINUM TUBE		
DIMENSIONS ARE IN INCHES		DRAWN				TITLE:
TOLERANCES:		CHECKED		DOM-PST30-40W-9-9AB3-RD-DIM-MSFS		
FRACTIONAL ±		ENG APPR.				
ANGULAR: MACH ± BEND ±		MFG APPR.				
TWO PLACE DECIMAL ±		Q.A.		SIZE	DWG. NO.	REV
THREE PLACE DECIMAL ±		COMMENTS:		<b>A</b>		
INTERPRET GEOMETRIC TOLERANCING PER:				SCALE: 1:2	WEIGHT:	SHEET 3 OF 6
MATERIAL						
FINISH						
DO NOT SCALE DRAWING						

5

4

3

2

1

ITEM NO.	PART NUMBER	DESCRIPTION	QTY.
1	DOM-PST30-40W-9-9AB3-RD-DIM-MSFS-POST-ANCHOR COVER	SPUN ALUMINUM 0.080"	1

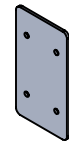
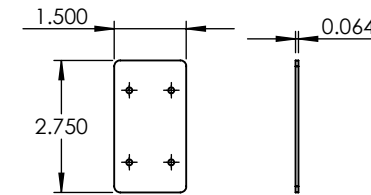
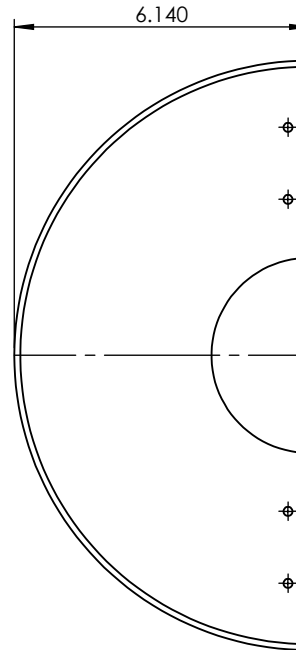
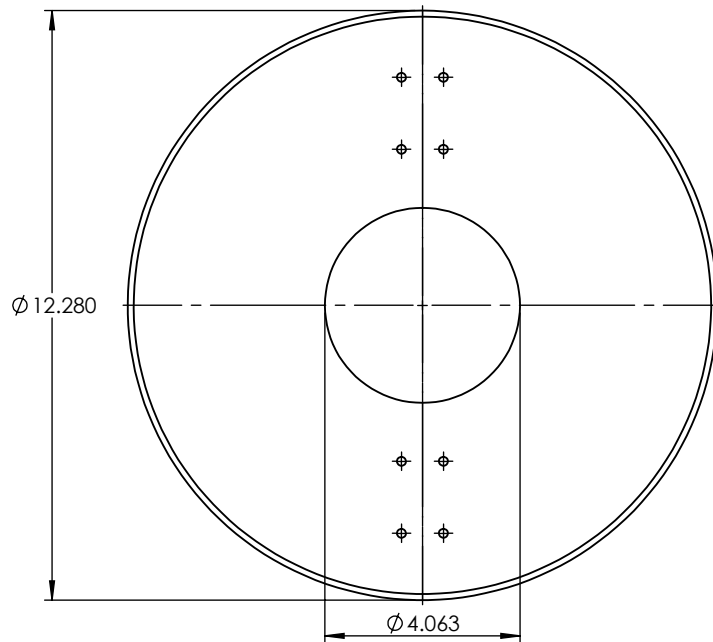
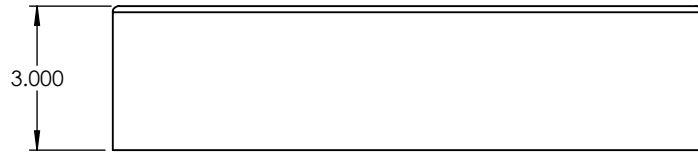
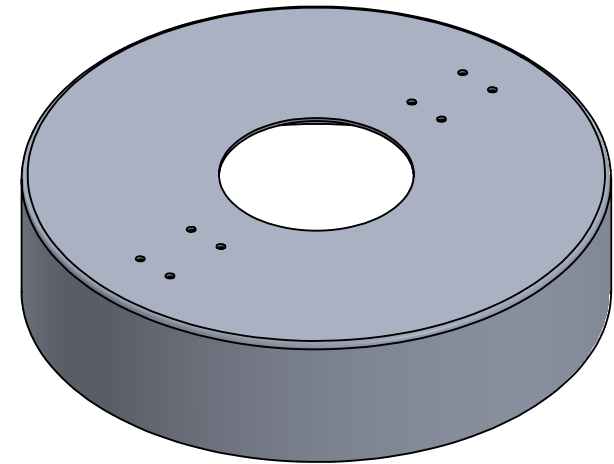

**PROPRIETARY AND CONFIDENTIAL**  
 THE INFORMATION CONTAINED IN THIS DRAWING IS THE SOLE PROPERTY OF <INSERT COMPANY NAME HERE>. ANY REPRODUCTION IN PART OR AS A WHOLE WITHOUT THE WRITTEN PERMISSION OF <INSERT COMPANY NAME HERE> IS PROHIBITED.

UNLESS OTHERWISE SPECIFIED:		NAME	DATE
DIMENSIONS ARE IN INCHES		DRAWN	
TOLERANCES:		CHECKED	
FRACTIONAL ±		ENG APPR.	
ANGULAR: MACH ± BEND ±		MFG APPR.	
TWO PLACE DECIMAL ±		Q.A.	
THREE PLACE DECIMAL ±		COMMENTS:	
INTERPRET GEOMETRIC TOLERANCING PER:			
MATERIAL			
FINISH			
NEXT ASSY	USED ON		
APPLICATION	DO NOT SCALE DRAWING		

SPUN ALUMINUM 0.080"

TITLE:  
 DOM-PST30-40W-9-9AB3-RD-DIM-MSFS

SIZE	DWG. NO.	REV
<b>A</b>		
SCALE: 1:4	WEIGHT:	SHEET 4 OF 6

5

4

3

2

1

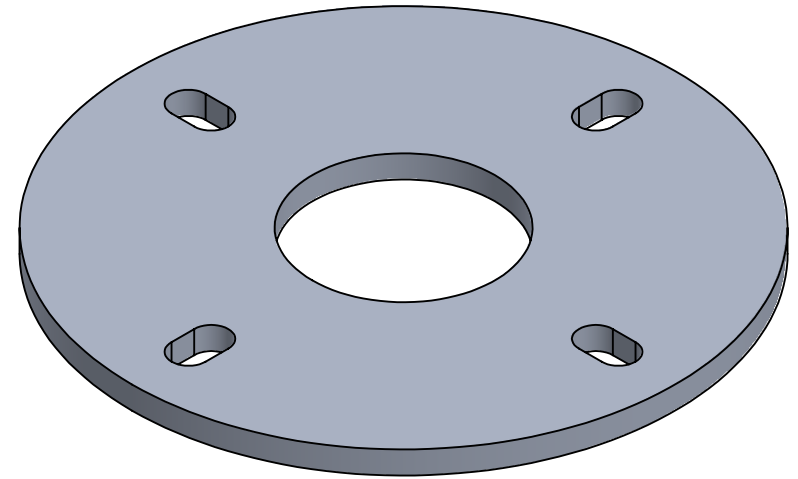
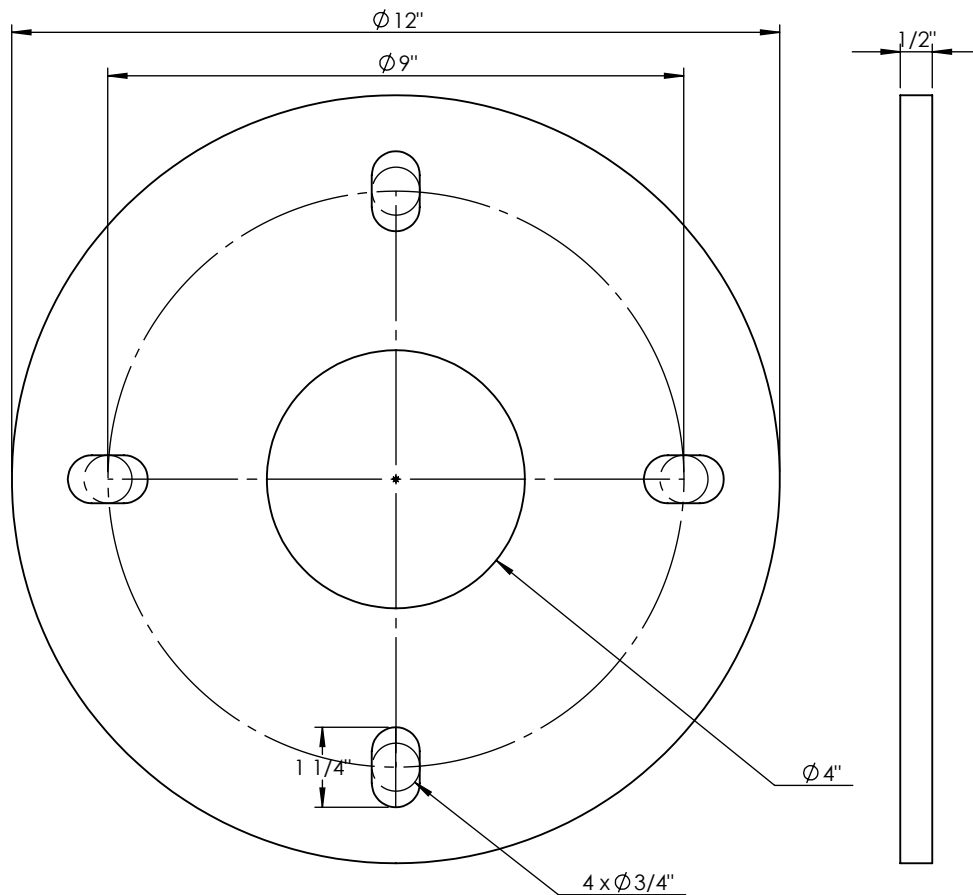

		UNLESS OTHERWISE SPECIFIED:	NAME	DATE	ALUMINUM 0.500" PLATE	
		DIMENSIONS ARE IN INCHES	DRAWN		TITLE:	
		TOLERANCES:	CHECKED		DOM-PST30-40W-9-9AB3-RD-DIM-MSFS	
		FRACTIONAL ±	ENG APPR.		SIZE	DWG. NO.
		ANGULAR: MACH ± BEND ±	MFG APPR.		<b>A</b>	REV
		TWO PLACE DECIMAL ±	Q.A.		SCALE: 1:3	WEIGHT:
		THREE PLACE DECIMAL ±	COMMENTS:			SHEET 5 OF 6
		INTERPRET GEOMETRIC TOLERANCING PER:				
		MATERIAL				
NEXT ASSY	USED ON	FINISH				
APPLICATION		DO NOT SCALE DRAWING				

5

4

3

2

1

