

ITEM NO.	PART NUMBER	DESCRIPTION	QTY.	CUT
1	PR-SHRD-12X12-55W-MBK-CFA-WET-30K-FRAME	ALUMINUM 0.0635"	1	
2	PR-SHRD-12X12-55W-MBK-CFA-WET-30K-END CAP	ALUMINUM 0.0635"	2	
3	PR-SHRD-12X12-55W-MBK-CFA-WET-30K-BACKPLATE	ALUMINUM 0.0635"	1	
4	PR-SHRD-12X12-55W-MBK-CFA-WET-30K-FIREPLATE	ALUMINUM 0.0635"	1	
5	PR-SHRD-12X12-55W-MBK-CFA-WET-30K-DOOR	ALUMINUM 0.0635"	1	
6	PR-SHRD-12X12-55W-MBK-CFA-WET-30K-DOOR BRACKET	ALUMINUM 0.0635"	1	
7	PR-SHRD-12X12-55W-MBK-CFA-WET-30K-LED BRACKET	ALUMINUM 0.0635"	1	
8	PR-SHRD-12X12-55W-MBK-CFA-WET-30K-ACRYLIC	ACRYLIC	1	
9	AItal_LED_PN1019_SHIM PLATE	ALUMINUM 0.125" PLATE	6	
10	KTLD-25-UV-700-VDIM-LA1	DRIVER	3	
11	AItal_LED_PN1019_RevC	LED	6	

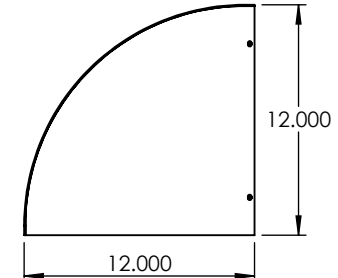
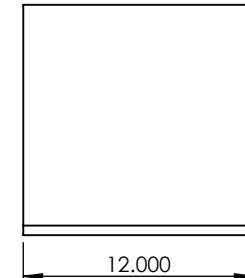
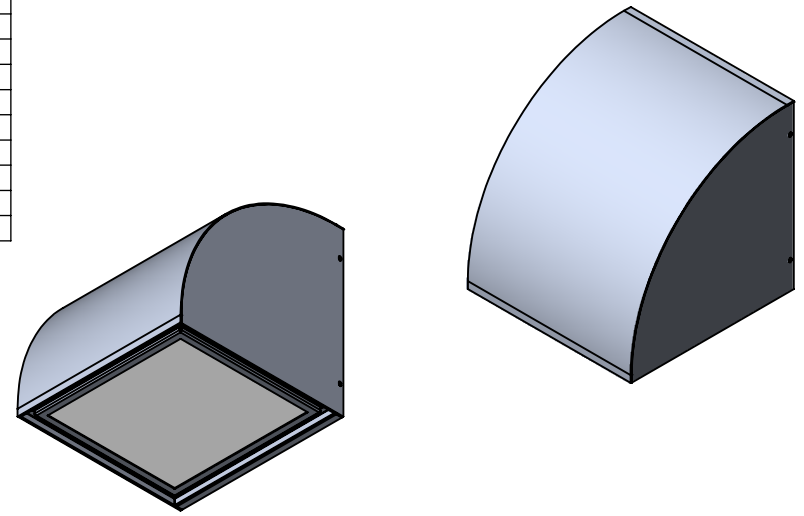
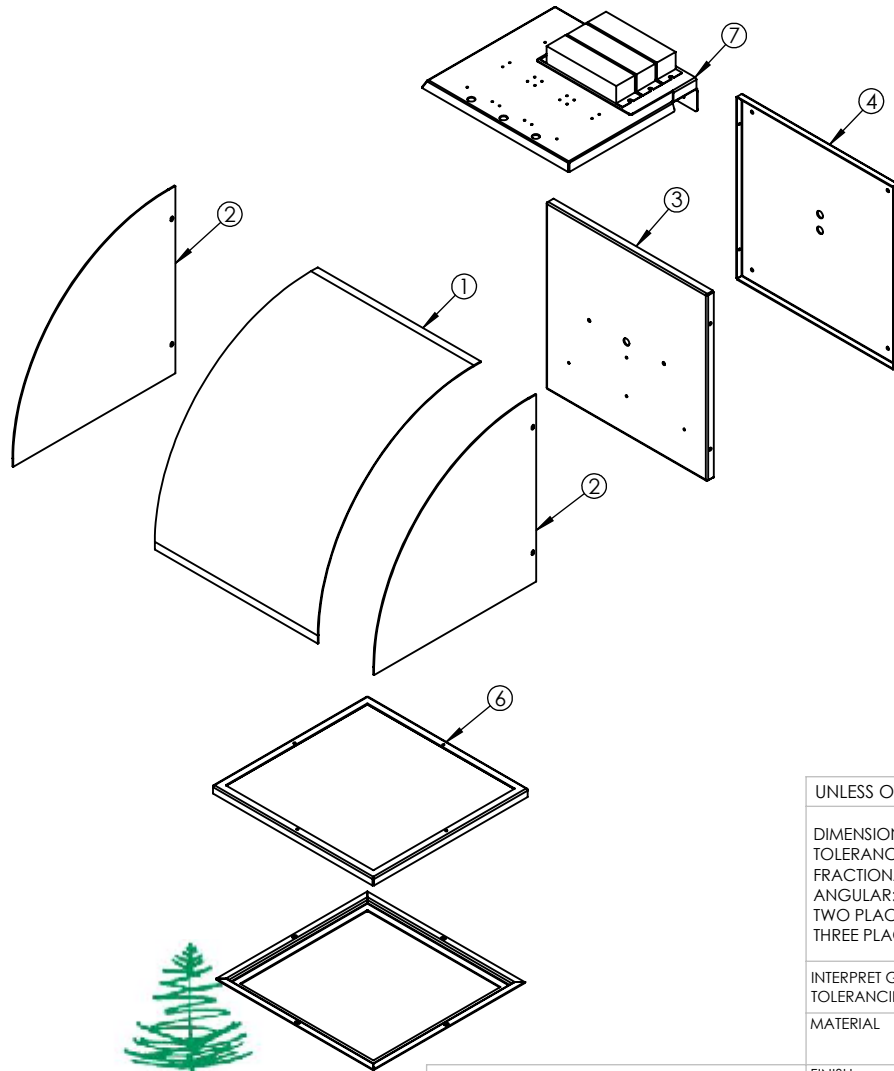

UNLESS OTHERWISE SPECIFIED:

DIMENSIONS ARE IN INCHES  
 TOLERANCES:  
 FRACTIONAL ± .003  
 ANGULAR: MACH ± .01 BEND ±  
 TWO PLACE DECIMAL ±  
 THREE PLACE DECIMAL ±.001

INTERPRET GEOMETRIC  
 TOLERANCING PER:

MATERIAL

FINISH

	NAME	DATE
DRAWN		
CHECKED		
ENG APPR.		
MFG APPR.		
Q.A.		
COMMENTS:		

TITLE:

PR-SHRD-12X12-55W-MBK-CFA-WET-30K

SIZE DWG. NO. REV  
**A** TICKET 25779

SCALE: 1:10 WEIGHT: SHEET 1 OF 9

**EVERGREEN LIGHTING**

ALL BEND RADIUS .030"

APPLICATION

DO NOT SCALE DRAWING

5

4

3

2

1

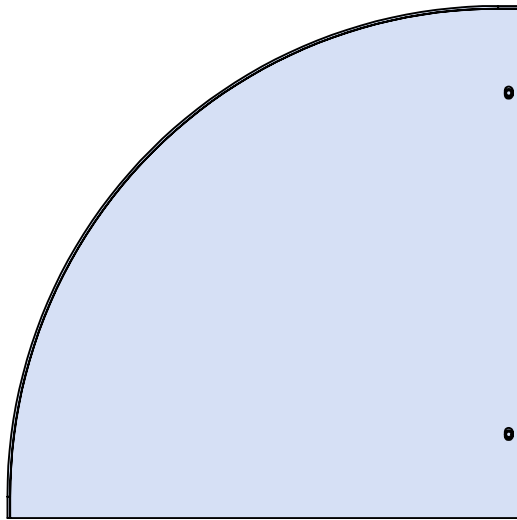
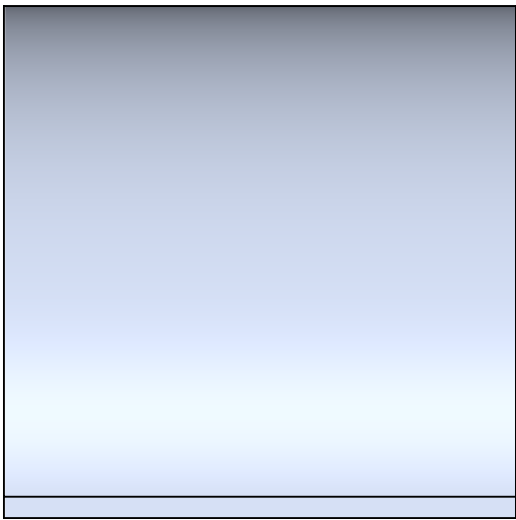
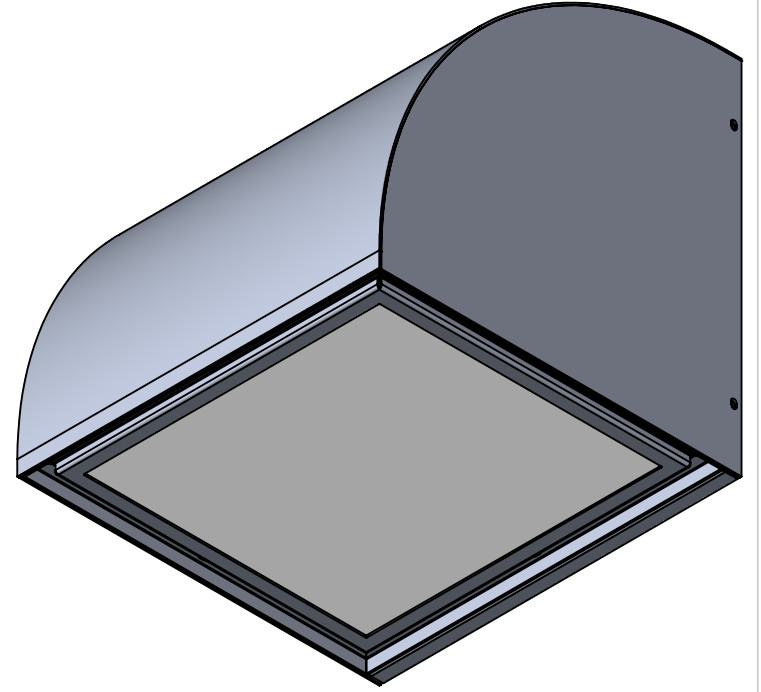
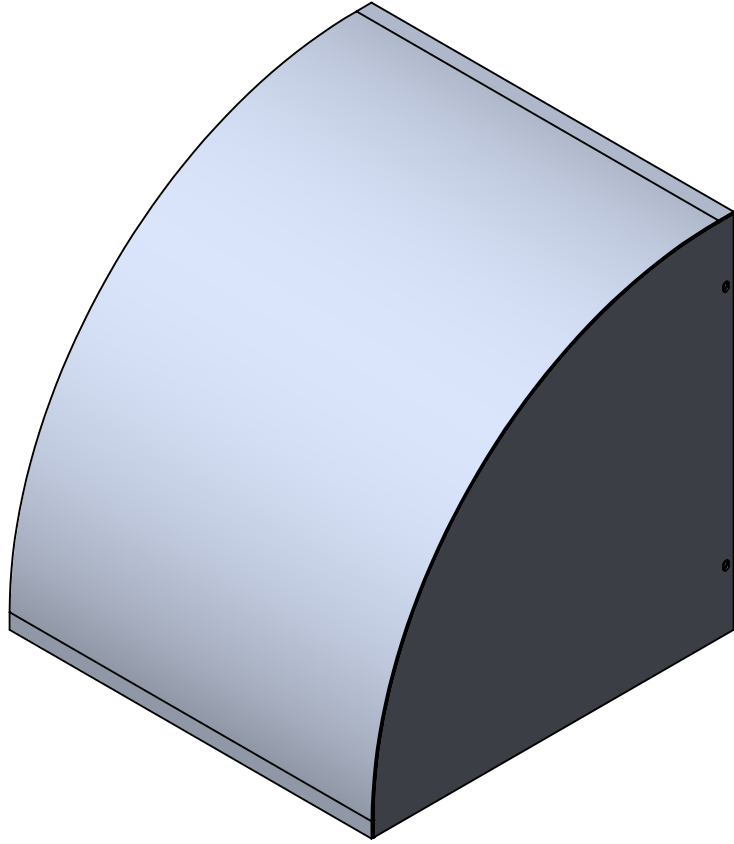

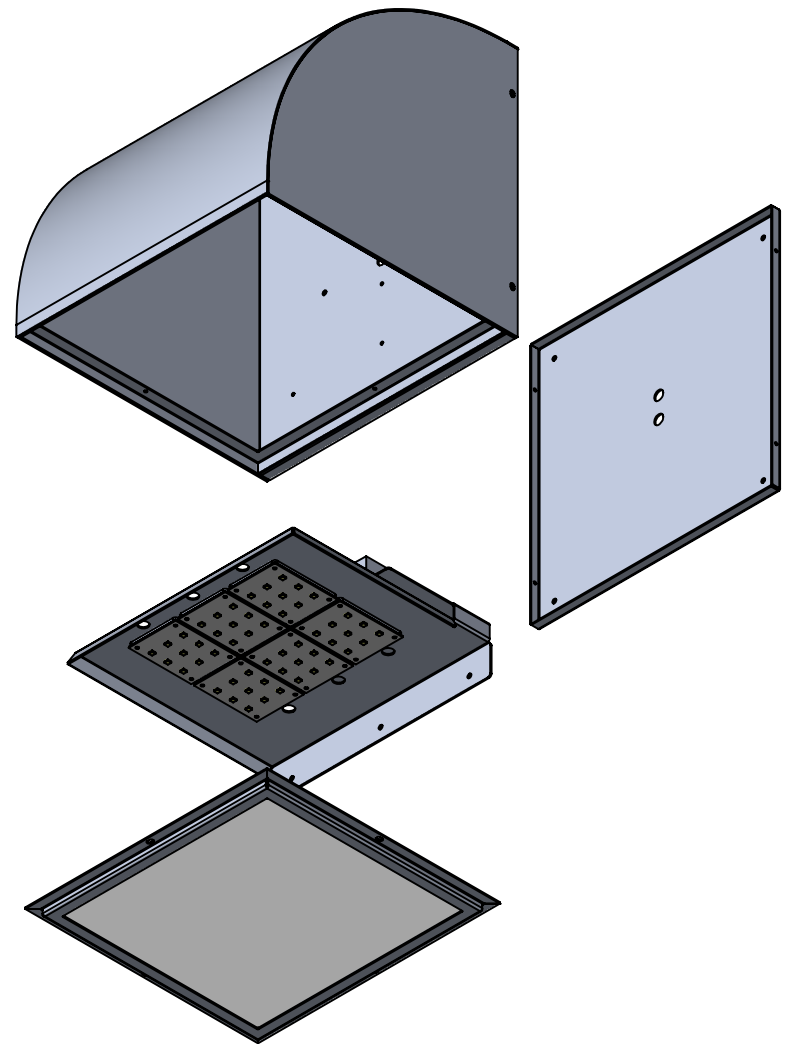
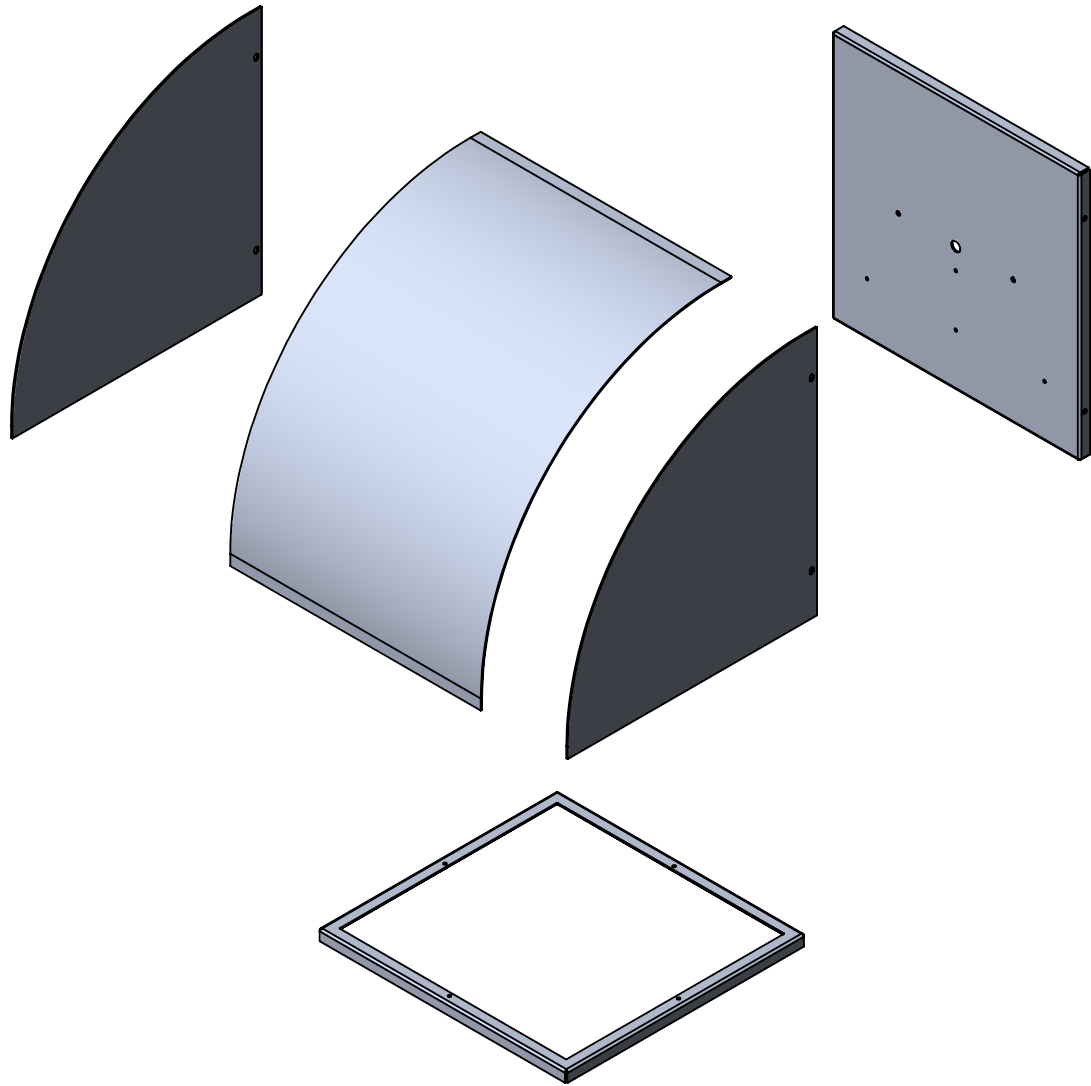

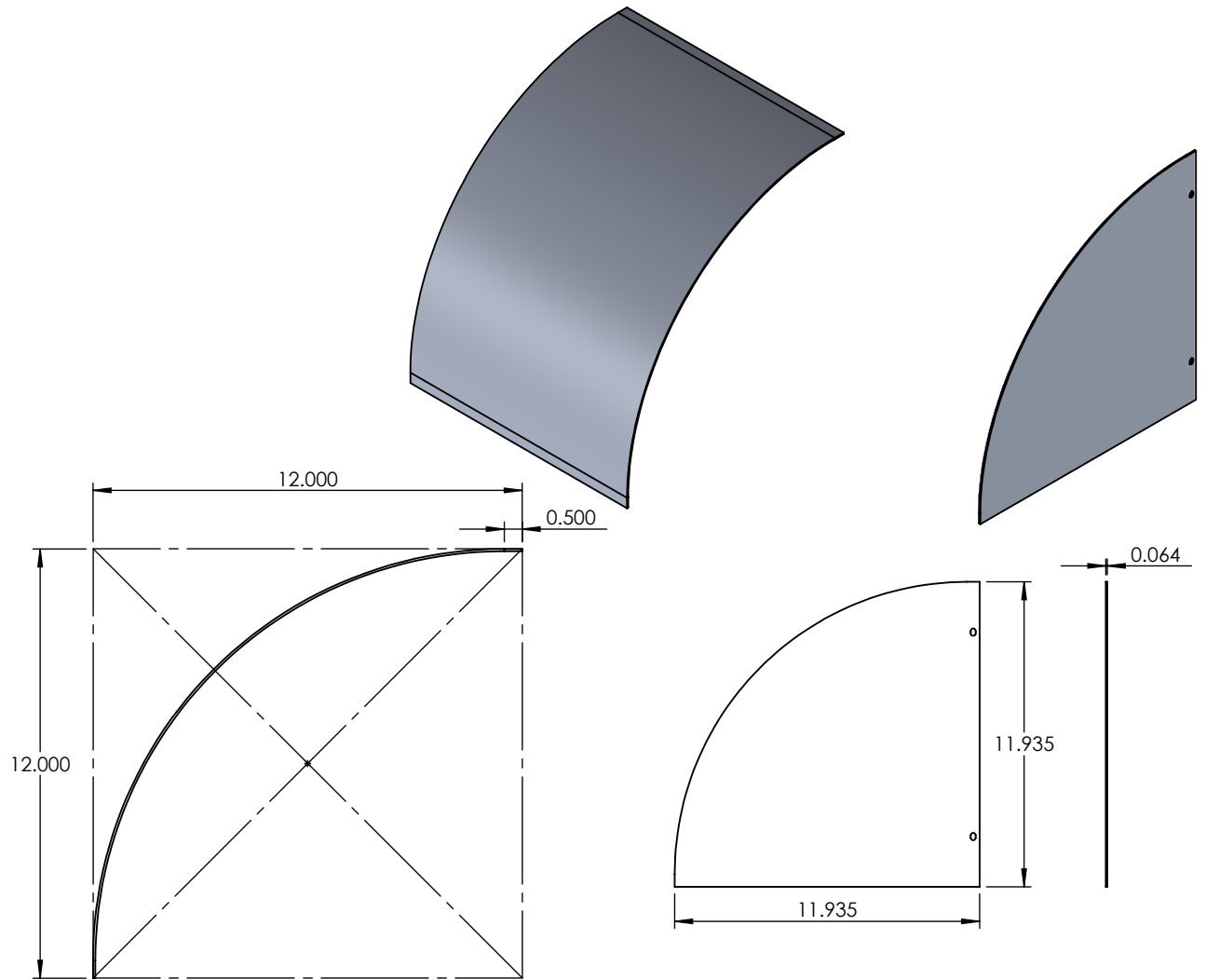
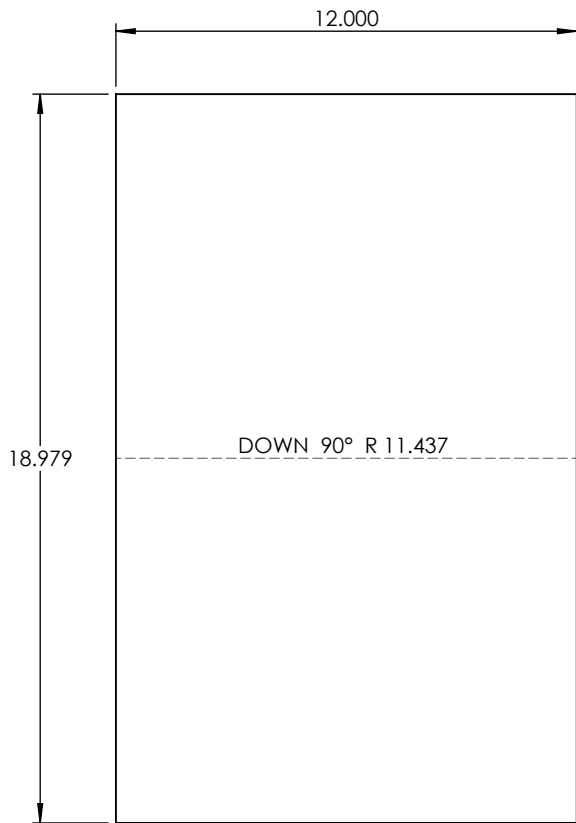

UNLESS OTHERWISE SPECIFIED:		NAME	DATE	ALUMINUM 0.0635"	
DIMENSIONS ARE IN INCHES TOLERANCES: FRACTIONAL ± ANGULAR: MACH ± BEND ± TWO PLACE DECIMAL ± THREE PLACE DECIMAL ±		DRAWN			
INTERPRET GEOMETRIC TOLERANCING PER:		CHECKED		PR-SHRD-12X12-55W-MBK-CFA-WET-30K	
		ENG APPR.			
MATERIAL		MFG APPR.		SIZE DWG. NO. REV	
		Q.A.			
FINISH		COMMENTS:		SCALE: 1:7 WEIGHT: SHEET 4 OF 9	

**PROPRIETARY AND CONFIDENTIAL**  
 THE INFORMATION CONTAINED IN THIS  
 DRAWING IS THE SOLE PROPERTY OF  
 <INSERT COMPANY NAME HERE>. ANY  
 REPRODUCTION IN PART OR AS A WHOLE  
 WITHOUT THE WRITTEN PERMISSION OF  
 <INSERT COMPANY NAME HERE> IS  
 PROHIBITED.

NEXT ASSY	USED ON
APPLICATION	

DO NOT SCALE DRAWING

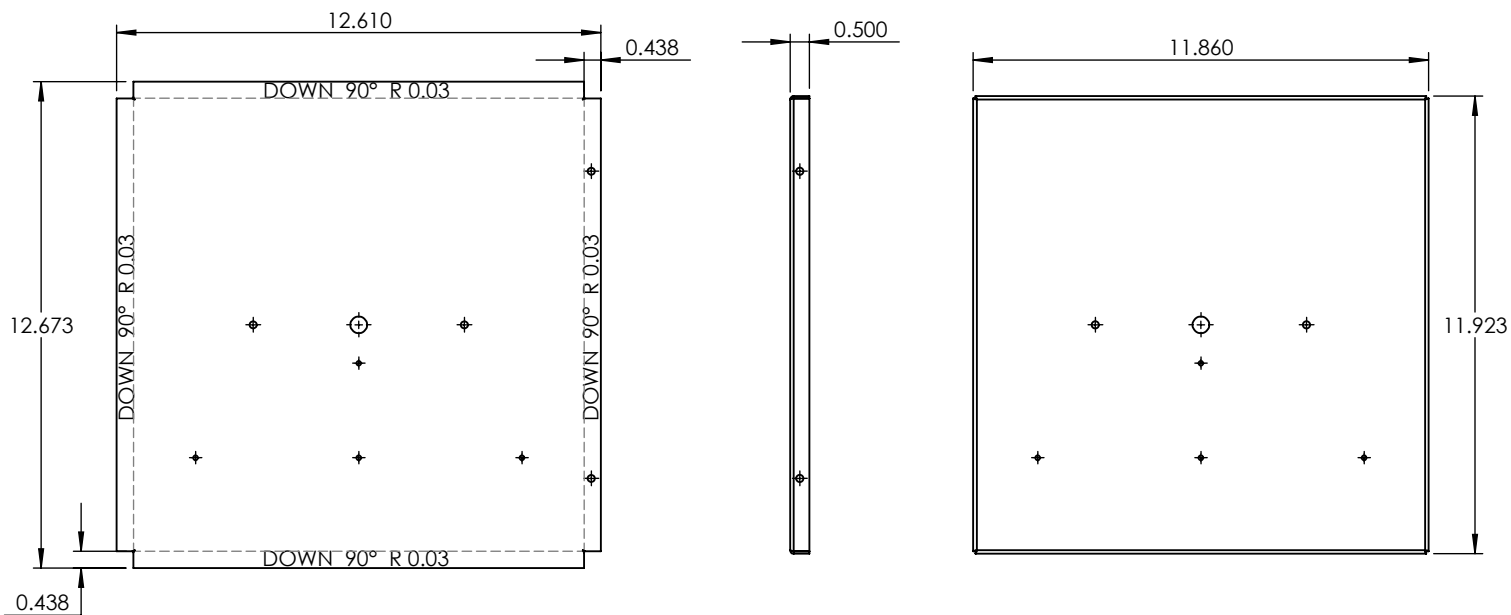
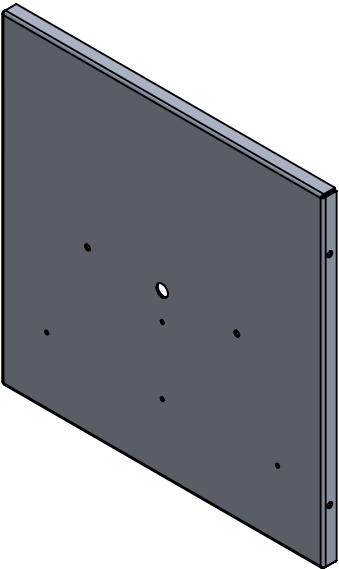

**PROPRIETARY AND CONFIDENTIAL**  
 THE INFORMATION CONTAINED IN THIS DRAWING IS THE SOLE PROPERTY OF <INSERT COMPANY NAME HERE>. ANY REPRODUCTION IN PART OR AS A WHOLE WITHOUT THE WRITTEN PERMISSION OF <INSERT COMPANY NAME HERE> IS PROHIBITED.

		UNLESS OTHERWISE SPECIFIED:		NAME	DATE	ALUMINUM 0.0635"	
		DIMENSIONS ARE IN INCHES				TITLE:	
		TOLERANCES:				PR-SHRD-12X12-55W-MBK-CFA-WET-30K	
		FRACTIONAL ±		DRAWN		SIZE DWG. NO. REV	
		ANGULAR: MACH ± BEND ±		CHECKED		A	
		TWO PLACE DECIMAL ±		ENG APPR.		SCALE: 1:5 WEIGHT: SHEET 5 OF 9	
		THREE PLACE DECIMAL ±		MFG APPR.			
		INTERPRET GEOMETRIC TOLERANCING PER:		Q.A.			
		MATERIAL		COMMENTS:			
		FINISH					
	NEXT ASSY	USED ON					
	APPLICATION		DO NOT SCALE DRAWING				

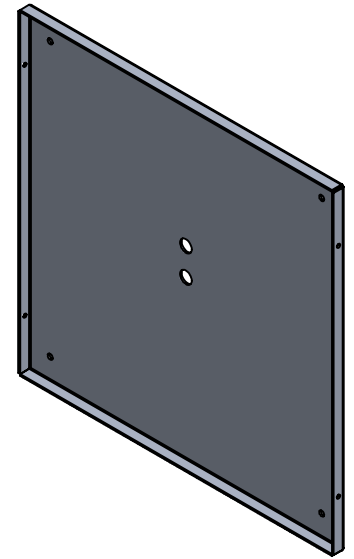
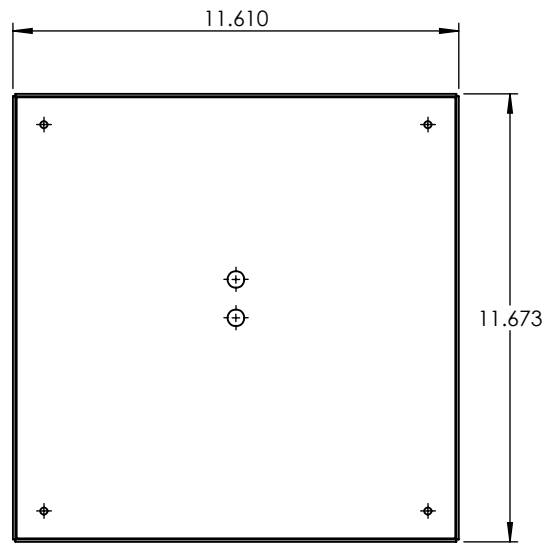
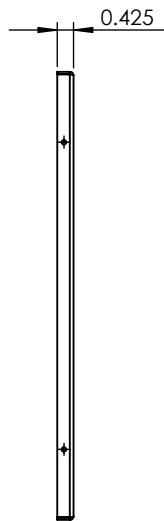
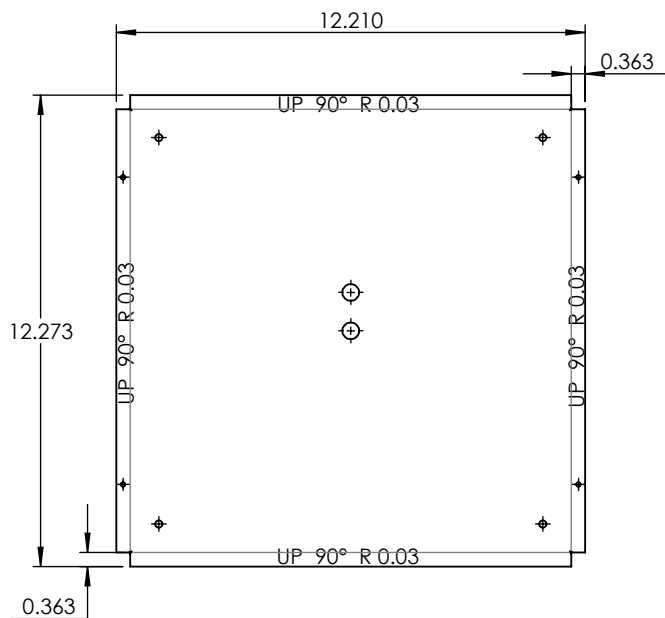

**PROPRIETARY AND CONFIDENTIAL**  
 THE INFORMATION CONTAINED IN THIS DRAWING IS THE SOLE PROPERTY OF <INSERT COMPANY NAME HERE>. ANY REPRODUCTION IN PART OR AS A WHOLE WITHOUT THE WRITTEN PERMISSION OF <INSERT COMPANY NAME HERE> IS PROHIBITED.

		UNLESS OTHERWISE SPECIFIED:		NAME	DATE	ALUMINUM 0.0635"		
		DIMENSIONS ARE IN INCHES		DRAWN		TITLE:		
		TOLERANCES:		CHECKED		PR-SHRD-12X12-55W-MBK-CFA-WET-30K		
		FRACTIONAL ±		ENG APPR.		SIZE DWG. NO. REV		
		ANGULAR: MACH ± BEND ±		MFG APPR.		A		
		TWO PLACE DECIMAL ±		Q.A.		SCALE: 1:5 WEIGHT: SHEET 6 OF 9		
		THREE PLACE DECIMAL ±		COMMENTS:				
		INTERPRET GEOMETRIC TOLERANCING PER:						
		MATERIAL						
	NEXT ASSY	USED ON	FINISH					
	APPLICATION		DO NOT SCALE DRAWING					

5

4

3

2

1

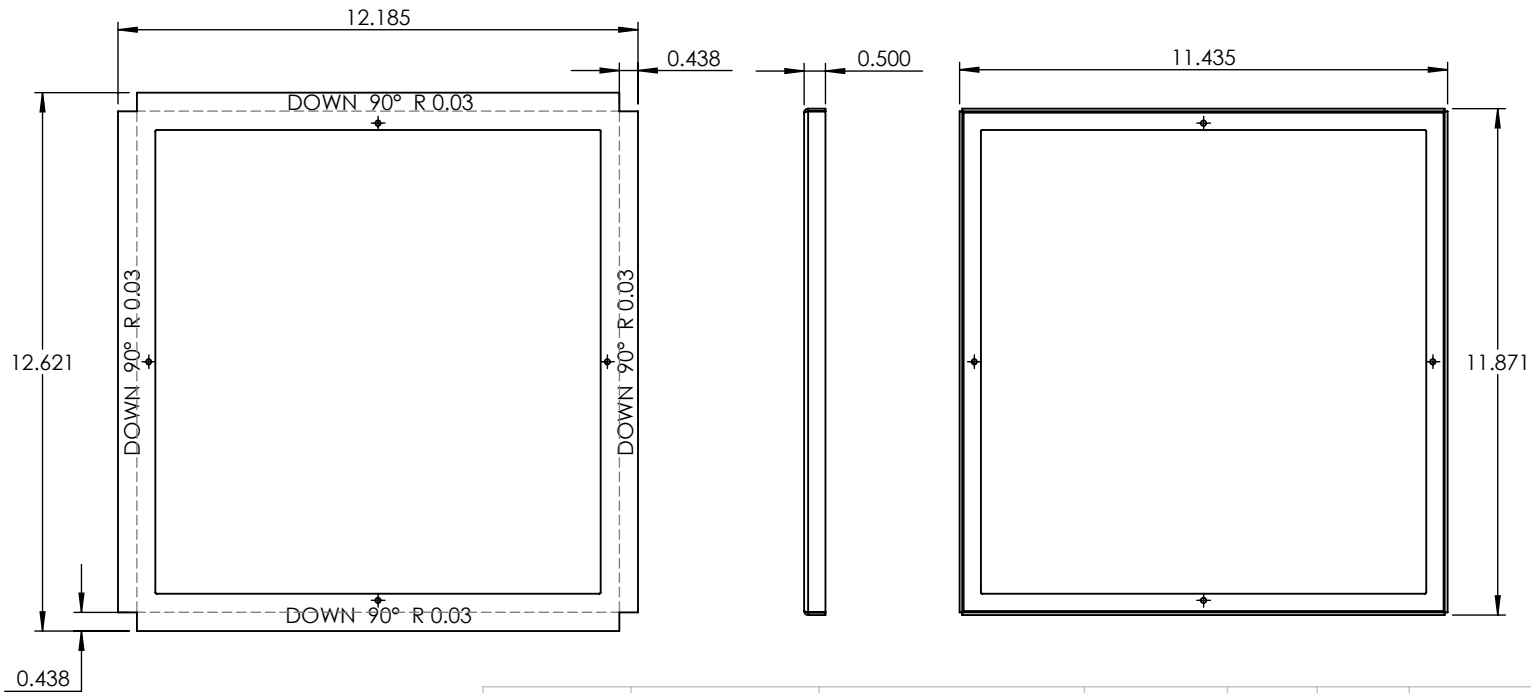
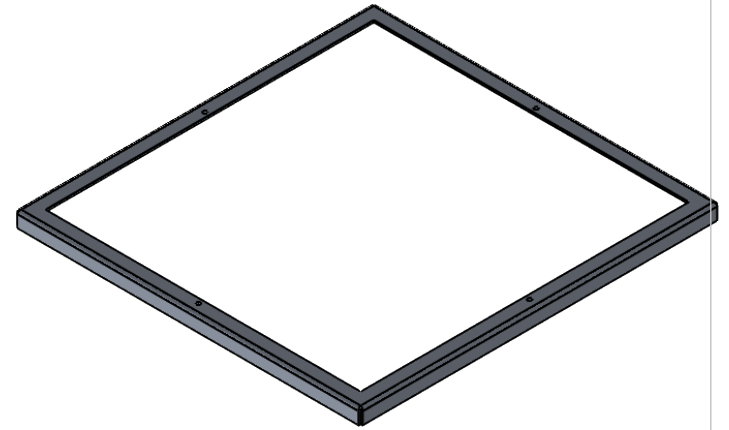

**PROPRIETARY AND CONFIDENTIAL**  
 THE INFORMATION CONTAINED IN THIS DRAWING IS THE SOLE PROPERTY OF <INSERT COMPANY NAME HERE>. ANY REPRODUCTION IN PART OR AS A WHOLE WITHOUT THE WRITTEN PERMISSION OF <INSERT COMPANY NAME HERE> IS PROHIBITED.

		UNLESS OTHERWISE SPECIFIED:		NAME	DATE	ALUMINUM 0.0635"	
		DIMENSIONS ARE IN INCHES TOLERANCES: FRACTIONAL ± ANGULAR: MACH ± BEND ± TWO PLACE DECIMAL ± THREE PLACE DECIMAL ±		DRAWN		TITLE:	
		INTERPRET GEOMETRIC TOLERANCING PER:		CHECKED		PR-SHRD-12X12-55W-MBK-CFA-WET-30K	
		MATERIAL		ENG APPR.		SIZE	DWG. NO.
		FINISH		MFG APPR.		<b>A</b>	REV
NEXT ASSY	USED ON			Q.A.		SCALE: 1:4.5WEIGHT:	
APPLICATION		DO NOT SCALE DRAWING		COMMENTS:		SHEET 7 OF 9	

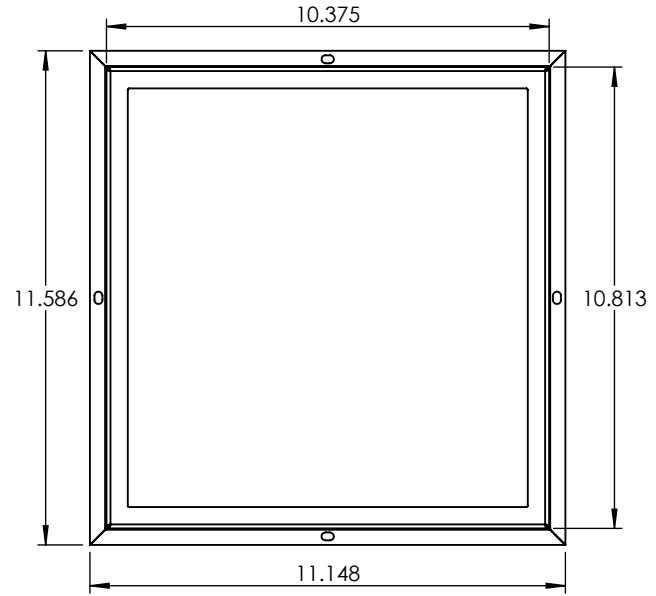
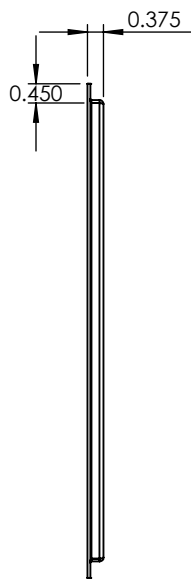
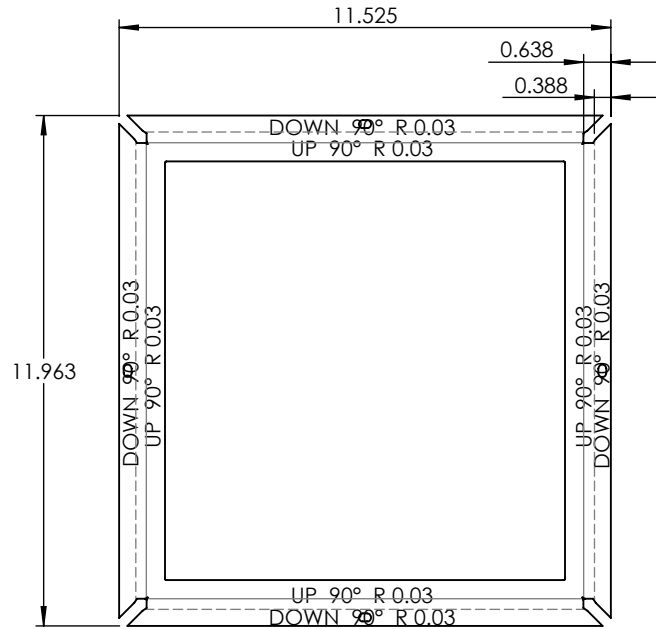
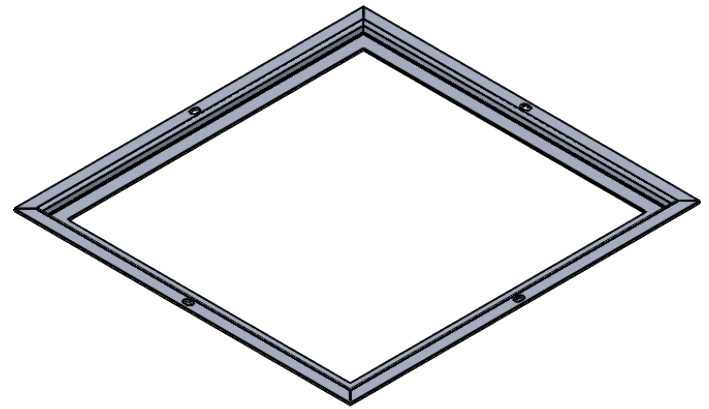

**PROPRIETARY AND CONFIDENTIAL**  
 THE INFORMATION CONTAINED IN THIS DRAWING IS THE SOLE PROPERTY OF <INSERT COMPANY NAME HERE>. ANY REPRODUCTION IN PART OR AS A WHOLE WITHOUT THE WRITTEN PERMISSION OF <INSERT COMPANY NAME HERE> IS PROHIBITED.

		UNLESS OTHERWISE SPECIFIED:	NAME	DATE
		DIMENSIONS ARE IN INCHES	DRAWN	
		TOLERANCES:	CHECKED	
		FRACTIONAL ±	ENG APPR.	
		ANGULAR: MACH ± BEND ±	MFG APPR.	
		TWO PLACE DECIMAL ±	Q.A.	
		THREE PLACE DECIMAL ±	COMMENTS:	
		INTERPRET GEOMETRIC TOLERANCING PER:		
		MATERIAL		
NEXT ASSY	USED ON	FINISH		
APPLICATION		DO NOT SCALE DRAWING		

ALUMINUM 0.0635"		
TITLE:		
PR-SHRD-12X12-55W-MBK-CFA-WET-30K		
SIZE	DWG. NO.	REV
<b>A</b>		
SCALE: 1:4.5	WEIGHT:	SHEET 8 OF 9

5

4

3

2

1



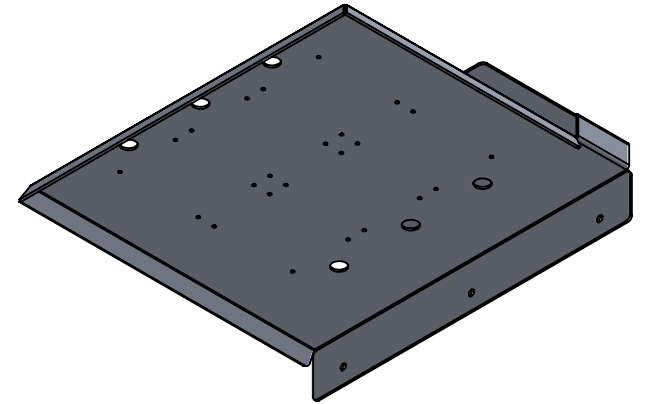
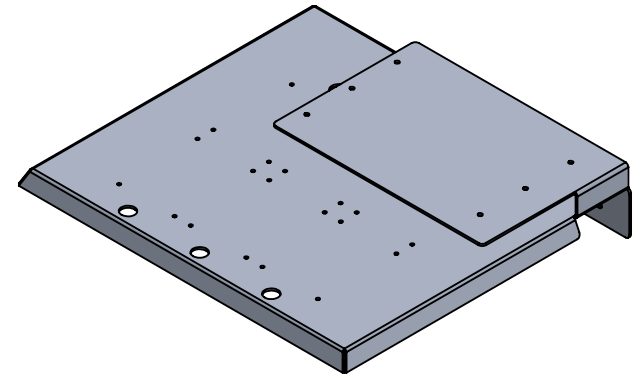
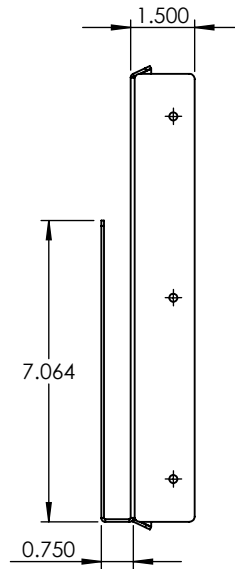
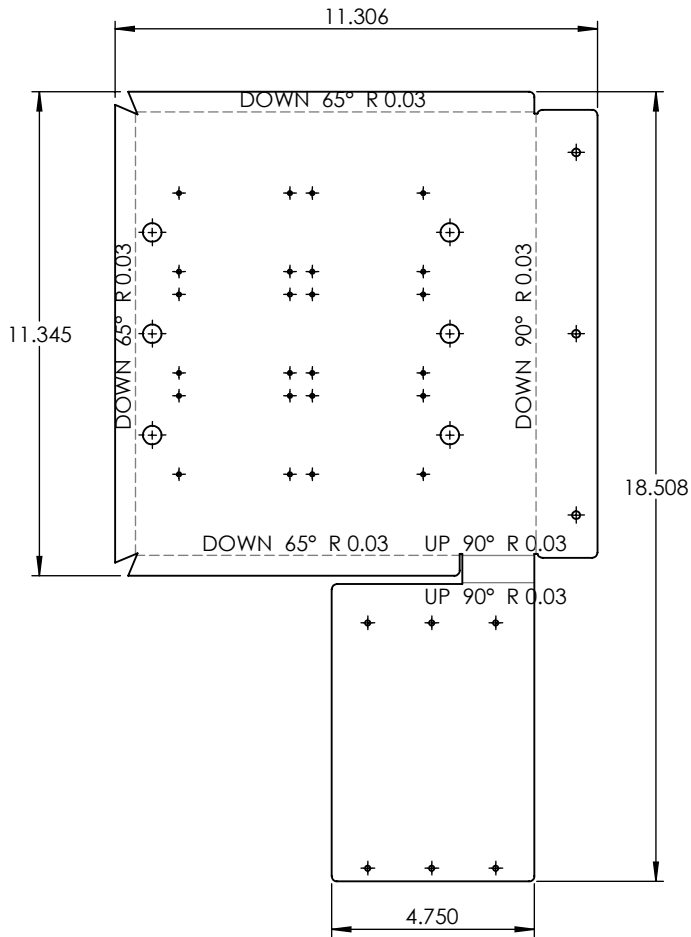
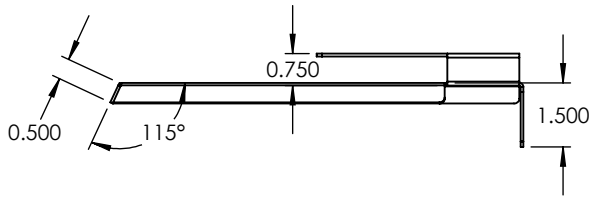

UNLESS OTHERWISE SPECIFIED:		NAME	DATE	ALUMINUM 0.0635"	
DIMENSIONS ARE IN INCHES		DRAWN		TITLE:	
TOLERANCES:		CHECKED		PR-SHRD-12X12-55W-MBK-CFA-WET-30K	
FRACTIONAL ±		ENG APPR.		SIZE	DWG. NO.
ANGULAR: MACH ± BEND ±		MFG APPR.		<b>A</b>	REV
TWO PLACE DECIMAL ±		Q.A.		SCALE: 1:4.5WEIGHT:	
THREE PLACE DECIMAL ±		COMMENTS:		SHEET 9 OF 9	
INTERPRET GEOMETRIC TOLERANCING PER:					
MATERIAL					
FINISH					
APPLICATION					
DO NOT SCALE DRAWING					

**PROPRIETARY AND CONFIDENTIAL**  
 THE INFORMATION CONTAINED IN THIS DRAWING IS THE SOLE PROPERTY OF <INSERT COMPANY NAME HERE>. ANY REPRODUCTION IN PART OR AS A WHOLE WITHOUT THE WRITTEN PERMISSION OF <INSERT COMPANY NAME HERE> IS PROHIBITED.

NEXT ASSY	USED ON
APPLICATION	