

ITEM NO.	PART NUMBER	DESCRIPTION	QTY.	CUT
1	HS-WANG-18L-TBR-A-TBL-WET-14"-35K-FRAME SHIELD	22 GAUGE	1	
2	HS-WANG-18L-TBR-A-TBL-WET-14"-35K-INNER FRAME	22 GAUGE	1	
3	HS-WANG-18L-TBR-A-TBL-WET-14"-35K-INNER CAP	22 GAUGE	2	
4	HS-WANG-18L-TBR-A-TBL-WET-14"-35K-BACKPLATE	22 GAUGE	1	
5	HS-WANG-18L-TBR-A-TBL-WET-14"-35K-FIREPLATE	22 GAUGE	1	
6	HS-WANG-18L-TBR-A-TBL-WET-14"-35K-FRAME	22 GAUGE	1	
7	HS-WANG-18L-TBR-A-TBL-WET-14"-35K-LED PLATE	22 GAUGE	2	
8	HS-WANG-18L-TBR-A-TBL-WET-14"-35K-ACRYLIC	ACRYLIC	2	
9	55MM HEXAGON HEAT SINK	HEAT SINK	2	
10	DS-15W-350C1542010-3001	DRIVER	2	
11	Alttailed_PCN_D1500_110B-10 WATT	LED	2	

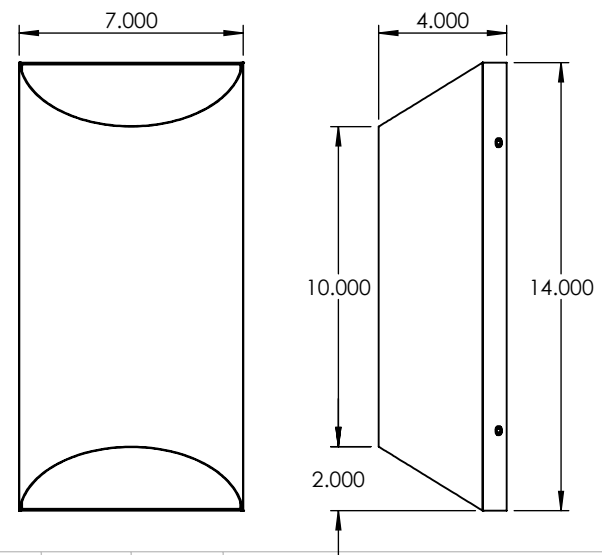
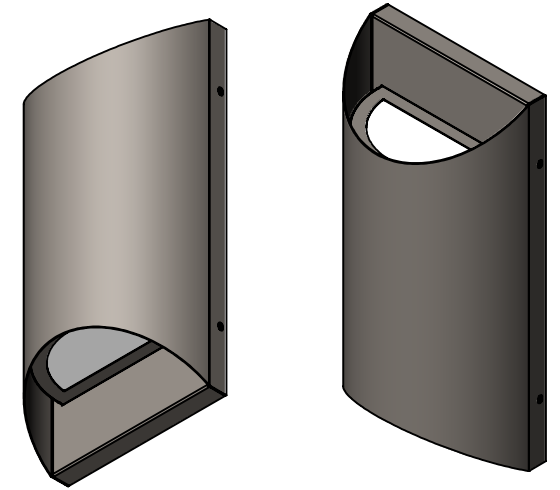
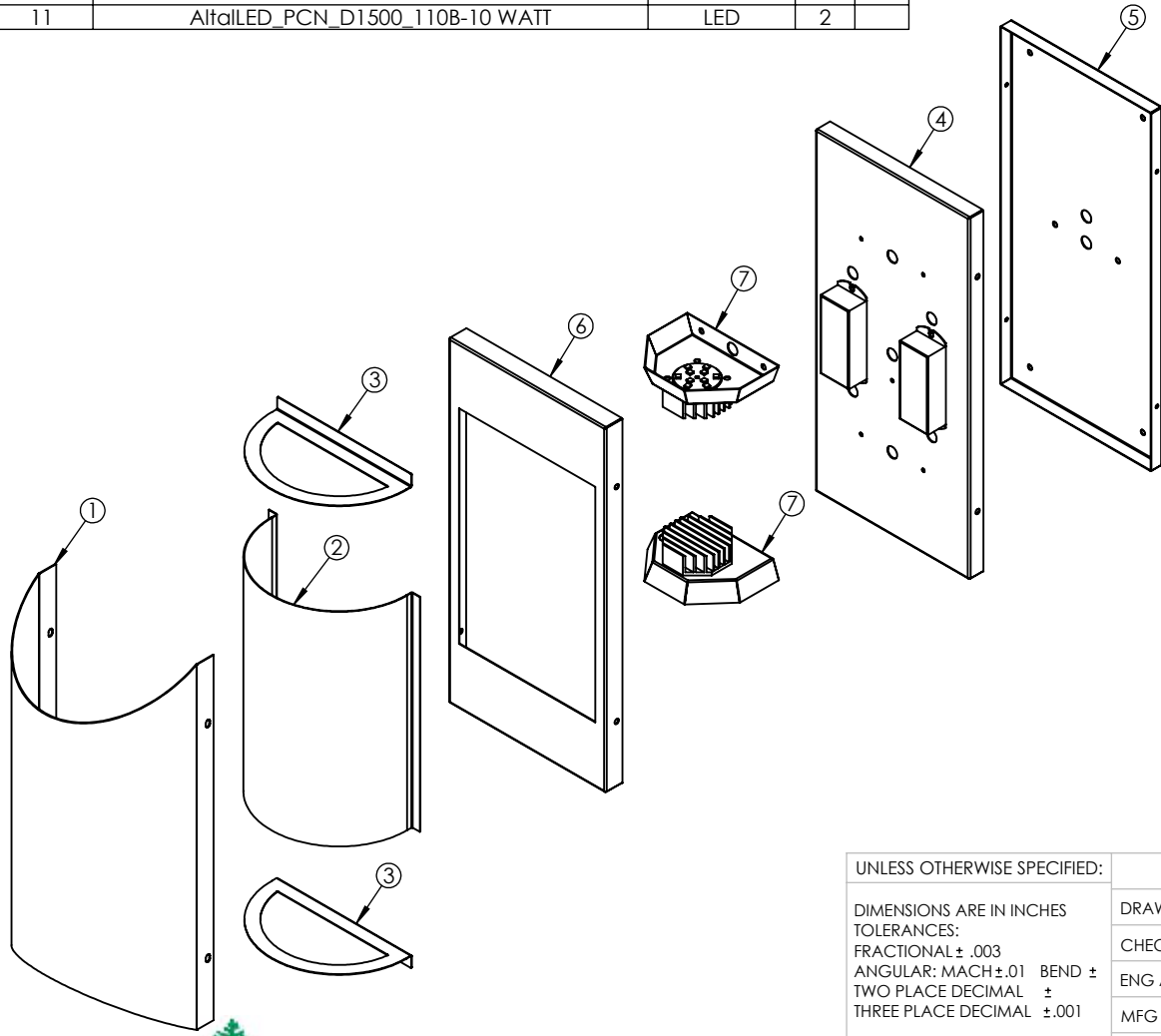

EVERGREEN LIGHTING

ALL BEND RADIUS .030"

UNLESS OTHERWISE SPECIFIED:	NAME	DATE
DIMENSIONS ARE IN INCHES	DRAWN	
TOLERANCES:	CHECKED	
FRACTIONAL ± .003	ENG APPR.	
ANGULAR: MACH ± .01 BEND ±	MFG APPR.	
TWO PLACE DECIMAL ±	Q.A.	
THREE PLACE DECIMAL ±.001	COMMENTS:	
INTERPRET GEOMETRIC TOLERANCING PER:		
MATERIAL		
FINISH		

TITLE:
HS-WANG-18L-TBR-A-TBL-WET-14"-35K

SIZE	DWG. NO.	REV
A	TICKET 26232	
SCALE: 1:6	WEIGHT:	SHEET 1 OF 9

5 4 3 2 1

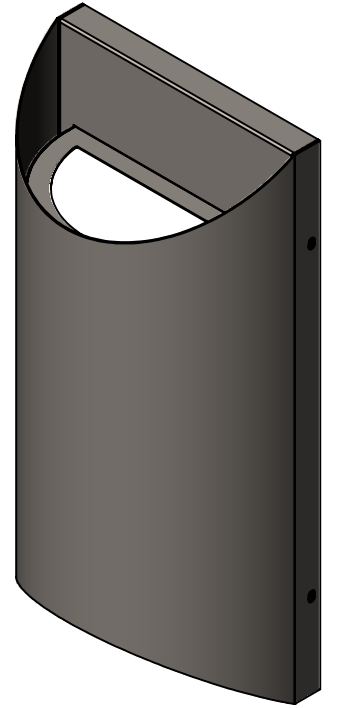
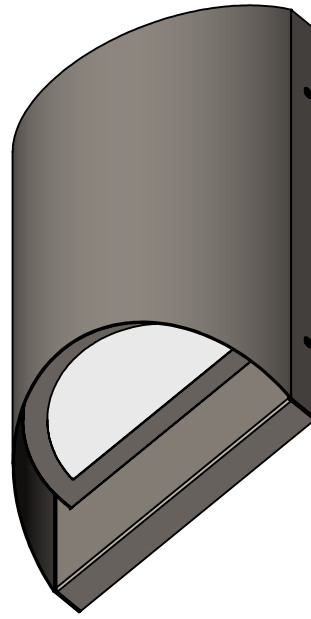
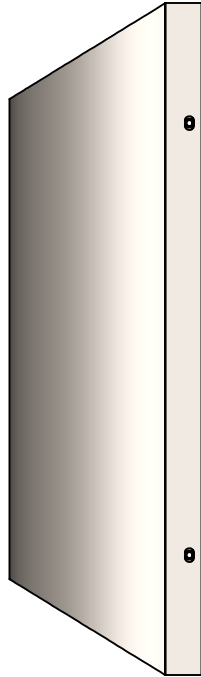
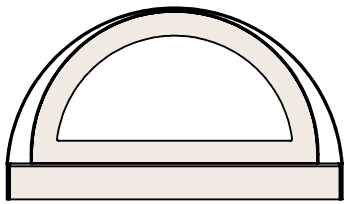
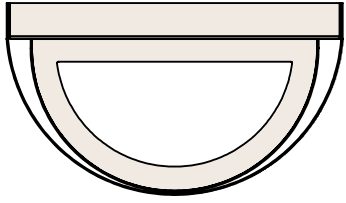

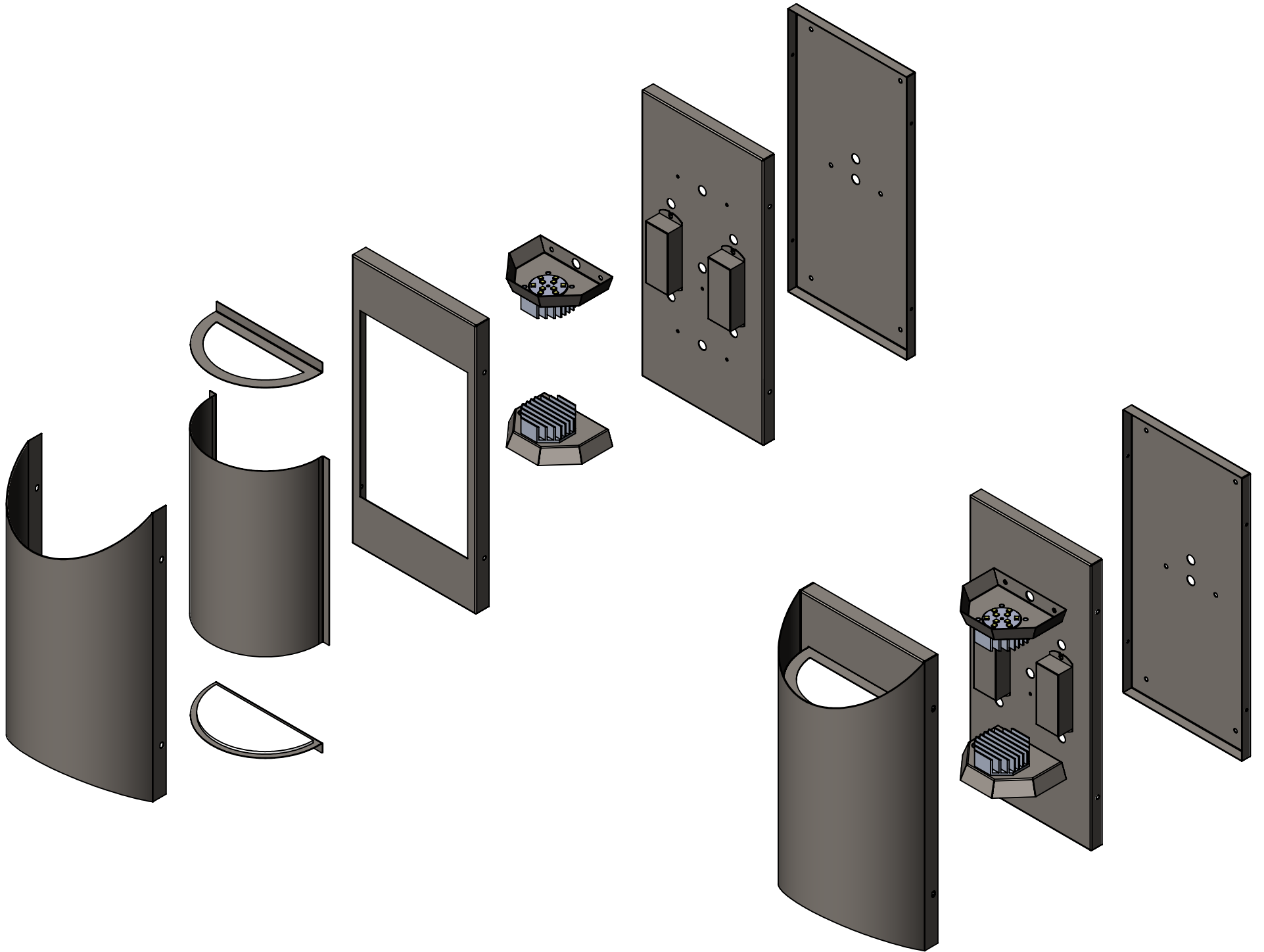

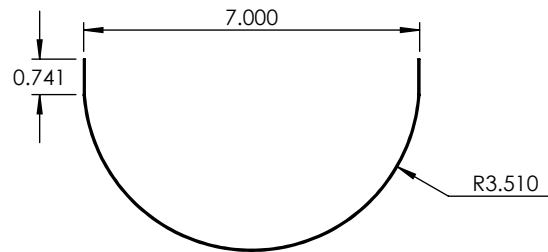
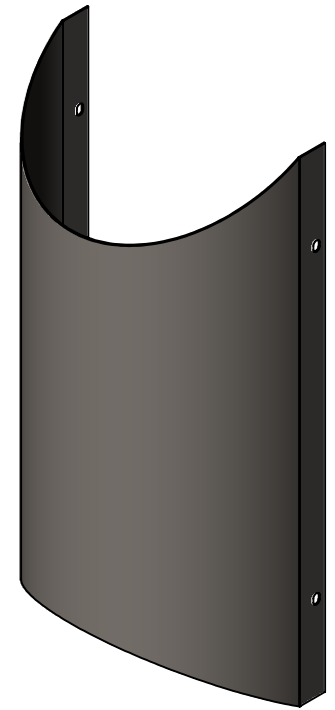
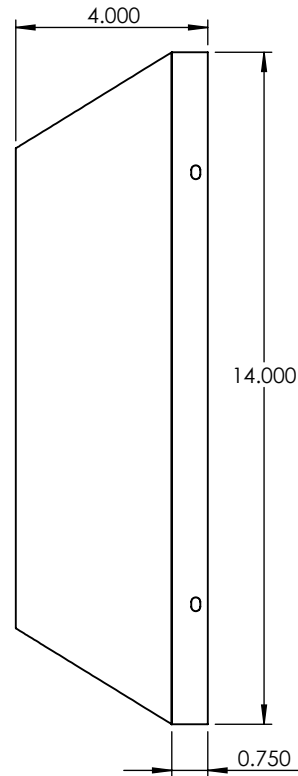
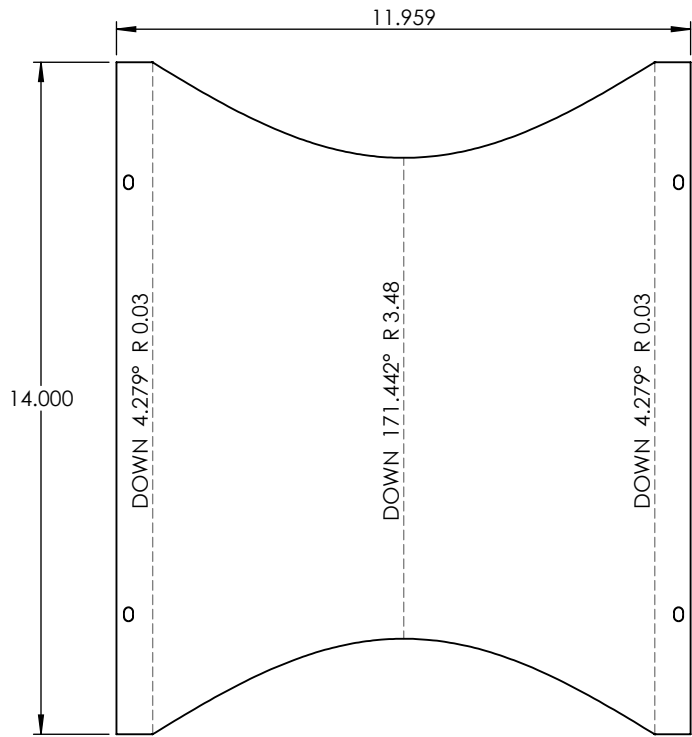

UNLESS OTHERWISE SPECIFIED:		NAME	DATE	22 GAUGE	
DIMENSIONS ARE IN INCHES TOLERANCES: FRACTIONAL ± ANGULAR: MACH ± BEND ± TWO PLACE DECIMAL ± THREE PLACE DECIMAL ±		DRAWN			
INTERPRET GEOMETRIC TOLERANCING PER:		CHECKED		SIZE DWG. NO. REV	
MATERIAL		ENG APPR.			
FINISH		MFG APPR.		COMMENTS:	
NEXT ASSY		Q.A.			
USED ON		COMMENTS:			
APPLICATION					

PROPRIETARY AND CONFIDENTIAL
THE INFORMATION CONTAINED IN THIS DRAWING IS THE SOLE PROPERTY OF <INSERT COMPANY NAME HERE>. ANY REPRODUCTION IN PART OR AS A WHOLE WITHOUT THE WRITTEN PERMISSION OF <INSERT COMPANY NAME HERE> IS PROHIBITED.

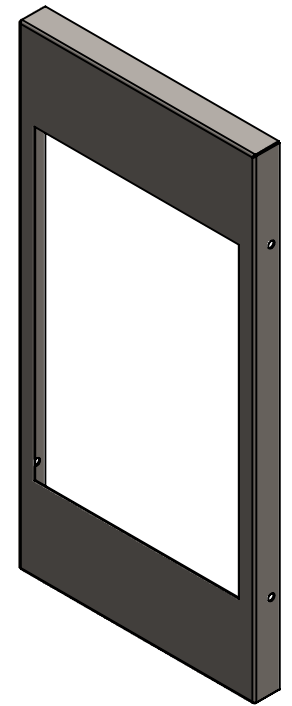
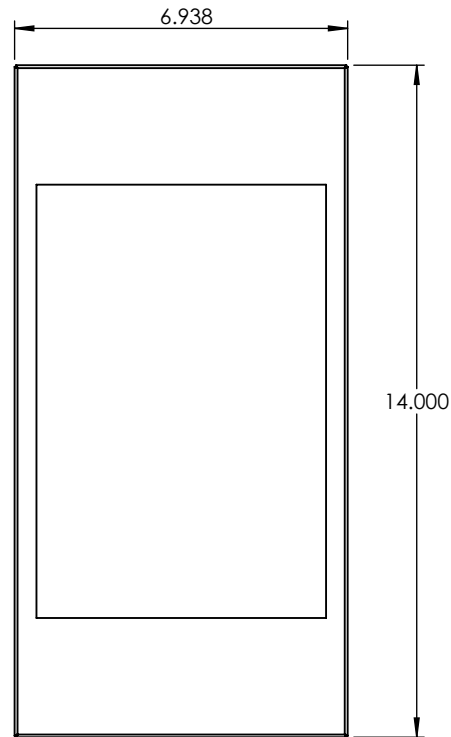
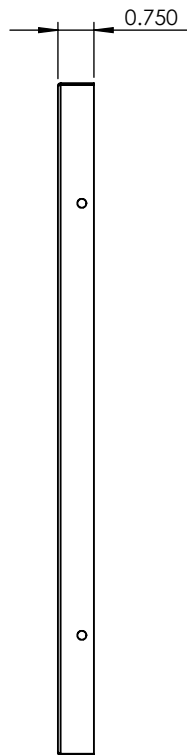
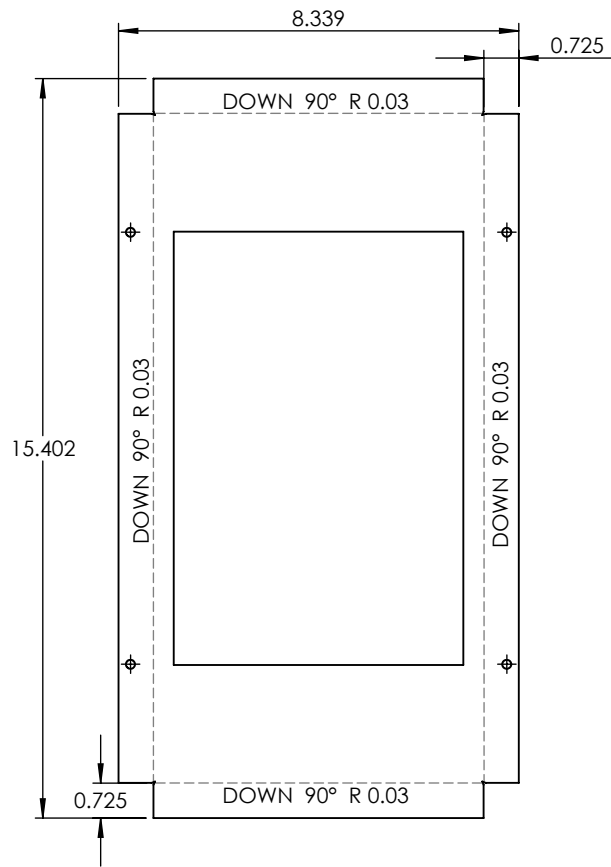

UNLESS OTHERWISE SPECIFIED:		NAME	DATE	22 GAUGE	
DIMENSIONS ARE IN INCHES TOLERANCES: FRACTIONAL ± ANGULAR: MACH ± BEND ± TWO PLACE DECIMAL ± THREE PLACE DECIMAL ±		DRAWN			
INTERPRET GEOMETRIC TOLERANCING PER:		CHECKED		HS-WANG-18L-TBR-A-TBL-WET-14"-35K	
		ENG APPR.			
		MFG APPR.			
MATERIAL		Q.A.		REV	
FINISH		COMMENTS:		SIZE DWG. NO.	
NEXT ASSY		USED ON		SCALE: 1:4 WEIGHT:	
APPLICATION		DO NOT SCALE DRAWING		SHEET 5 OF 9	

PROPRIETARY AND CONFIDENTIAL
THE INFORMATION CONTAINED IN THIS DRAWING IS THE SOLE PROPERTY OF <INSERT COMPANY NAME HERE>. ANY REPRODUCTION IN PART OR AS A WHOLE WITHOUT THE WRITTEN PERMISSION OF <INSERT COMPANY NAME HERE> IS PROHIBITED.

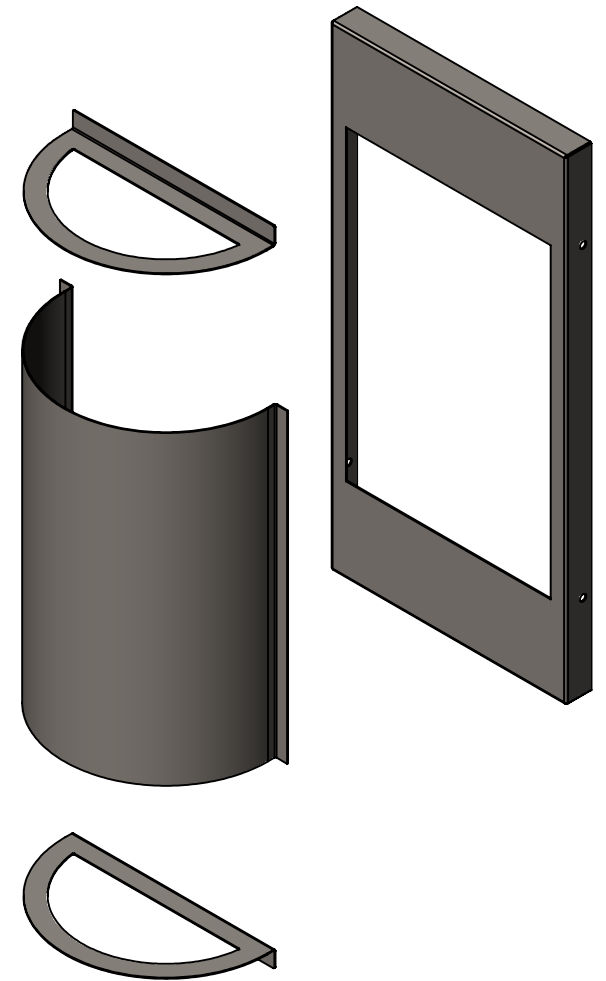
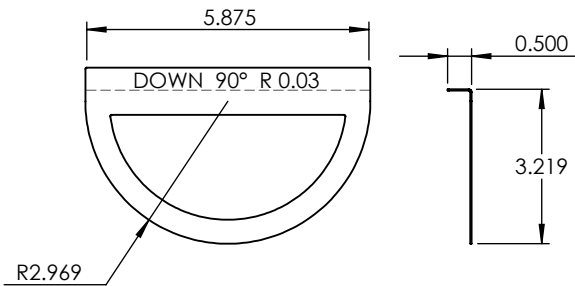
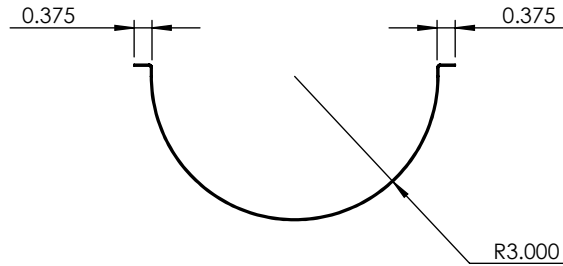
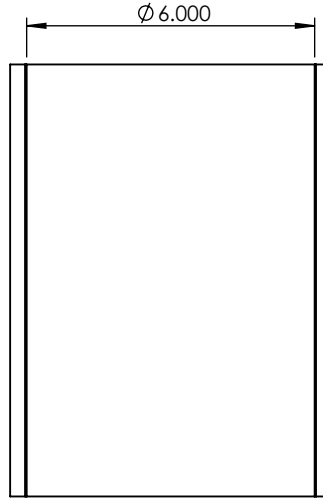
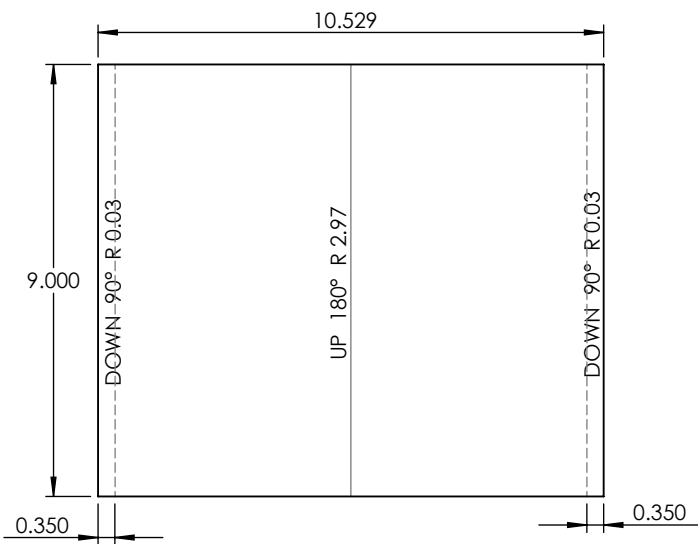

UNLESS OTHERWISE SPECIFIED:

DIMENSIONS ARE IN INCHES
 TOLERANCES:
 FRACTIONAL ±
 ANGULAR: MACH ± BEND ±
 TWO PLACE DECIMAL ±
 THREE PLACE DECIMAL ±

INTERPRET GEOMETRIC
 TOLERANCING PER:

MATERIAL

FINISH

DO NOT SCALE DRAWING

NAME DATE

DRAWN
 CHECKED
 ENG APPR.
 MFG APPR.

Q.A.
 COMMENTS:

22 GAUGE

TITLE:

HS-WANG-18L-TBR-A-TBL-WET-14"-35K

SIZE DWG. NO. REV

A

SCALE: 1:4 WEIGHT: SHEET 6 OF 9

PROPRIETARY AND CONFIDENTIAL
 THE INFORMATION CONTAINED IN THIS
 DRAWING IS THE SOLE PROPERTY OF
 <INSERT COMPANY NAME HERE>. ANY
 REPRODUCTION IN PART OR AS A WHOLE
 WITHOUT THE WRITTEN PERMISSION OF
 <INSERT COMPANY NAME HERE> IS
 PROHIBITED.

NEXT ASSY	USED ON
APPLICATION	

5

4

3

2

1

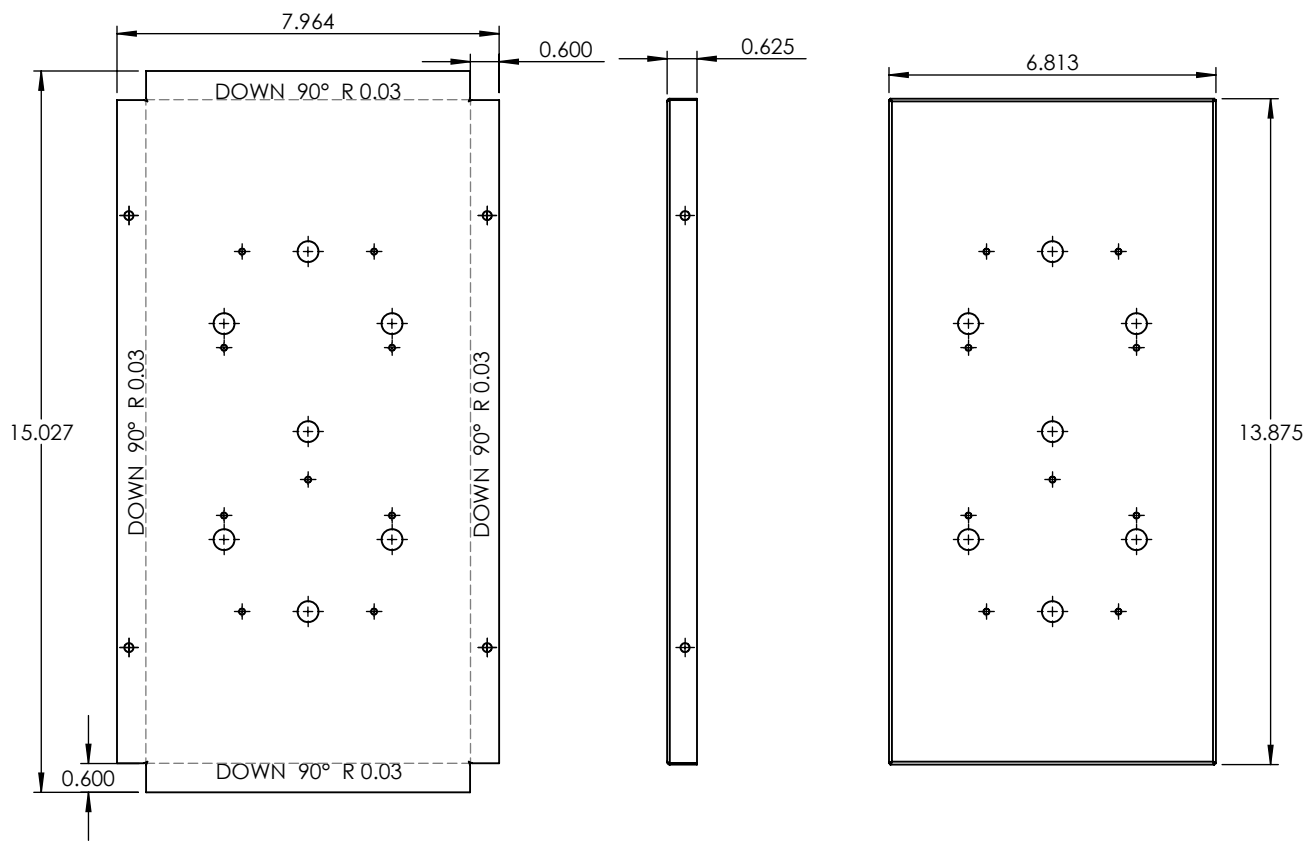
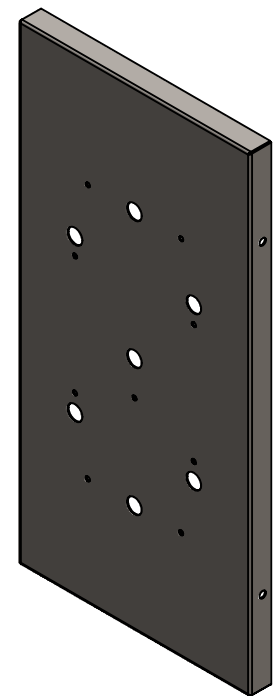

PROPRIETARY AND CONFIDENTIAL
 THE INFORMATION CONTAINED IN THIS DRAWING IS THE SOLE PROPERTY OF <INSERT COMPANY NAME HERE>. ANY REPRODUCTION IN PART OR AS A WHOLE WITHOUT THE WRITTEN PERMISSION OF <INSERT COMPANY NAME HERE> IS PROHIBITED.

		UNLESS OTHERWISE SPECIFIED:		NAME	DATE
		DIMENSIONS ARE IN INCHES	DRAWN		
		TOLERANCES:	CHECKED		
		FRACTIONAL ±	ENG APPR.		
		ANGULAR: MACH ± BEND ±	MFG APPR.		
		TWO PLACE DECIMAL ±	Q.A.		
		THREE PLACE DECIMAL ±	COMMENTS:		
		INTERPRET GEOMETRIC TOLERANCING PER:			
		MATERIAL			
		FINISH			
NEXT ASSY	USED ON				
APPLICATION		DO NOT SCALE DRAWING			

22 GAUGE		
TITLE:		
HS-WANG-18L-TBR-A-TBL-WET-14"-35K		
SIZE	DWG. NO.	REV
A		
SCALE: 1:4	WEIGHT:	SHEET 7 OF 9

5

4

3

2

1

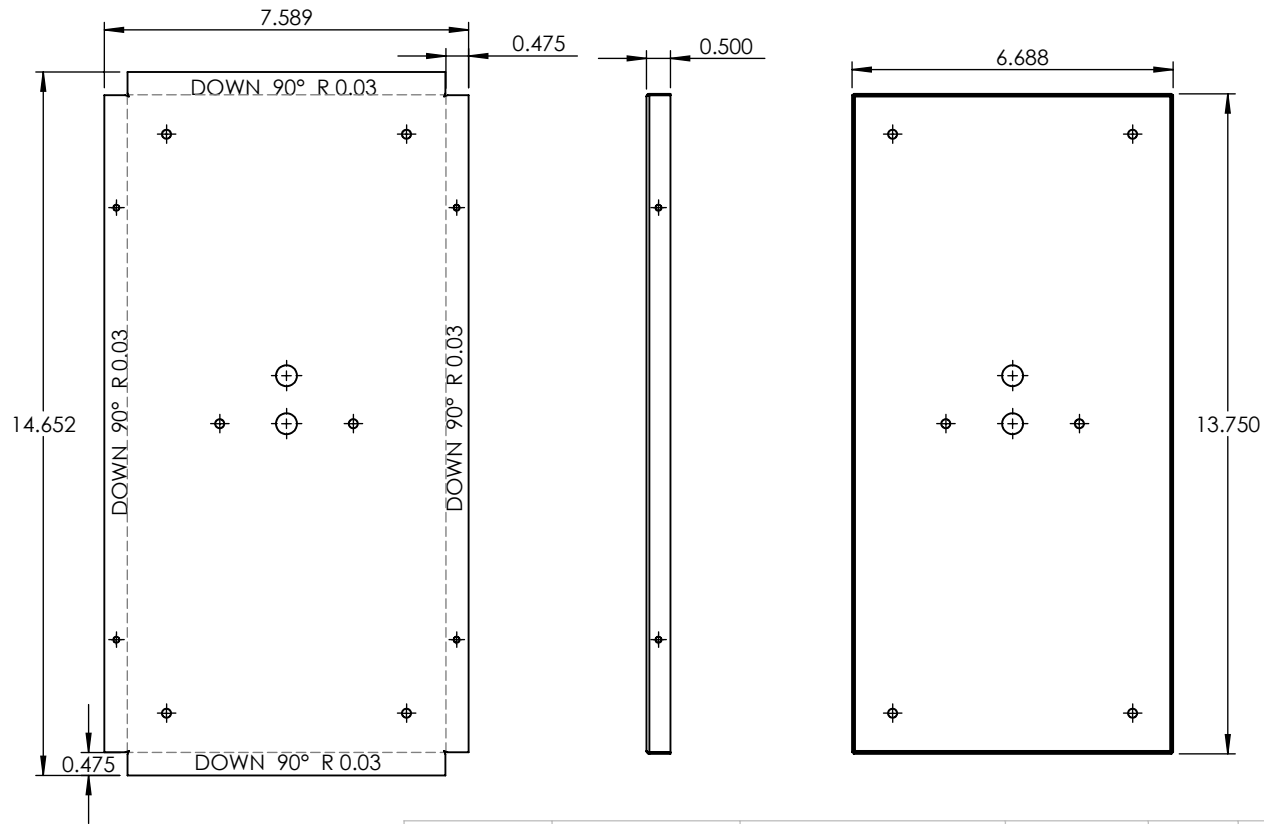
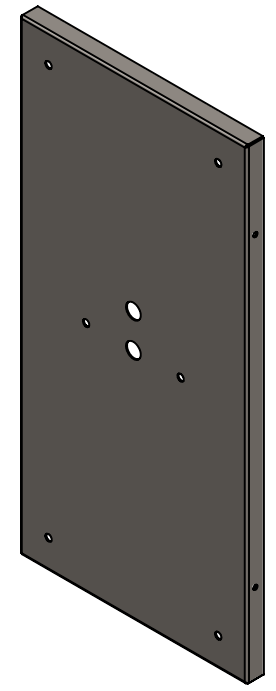

PROPRIETARY AND CONFIDENTIAL
 THE INFORMATION CONTAINED IN THIS DRAWING IS THE SOLE PROPERTY OF <INSERT COMPANY NAME HERE>. ANY REPRODUCTION IN PART OR AS A WHOLE WITHOUT THE WRITTEN PERMISSION OF <INSERT COMPANY NAME HERE> IS PROHIBITED.

		UNLESS OTHERWISE SPECIFIED:	NAME	DATE	22 GAUGE	
		DIMENSIONS ARE IN INCHES TOLERANCES: FRACTIONAL ± ANGULAR: MACH ± BEND ± TWO PLACE DECIMAL ± THREE PLACE DECIMAL ±	DRAWN			
		INTERPRET GEOMETRIC TOLERANCING PER:	CHECKED		SIZE DWG. NO. REV	
		MATERIAL	ENG APPR.			
		FINISH	MFG APPR.			
NEXT ASSY	USED ON		Q.A.			
APPLICATION		DO NOT SCALE DRAWING	COMMENTS:			

5

4

3

2

1

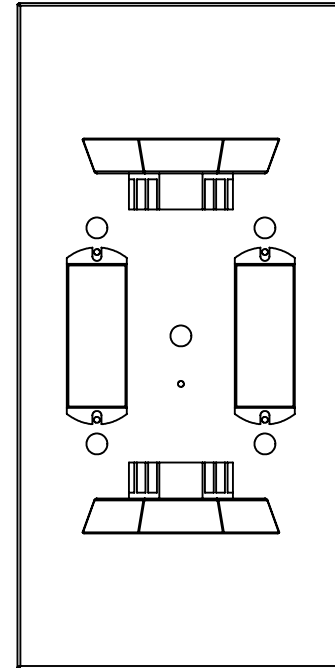
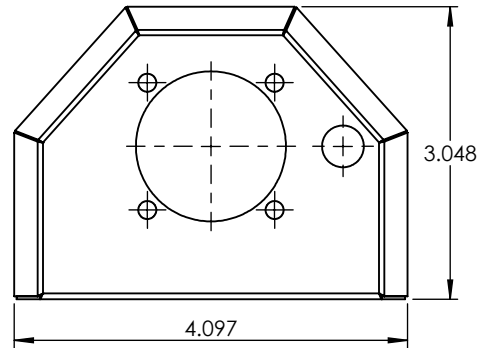
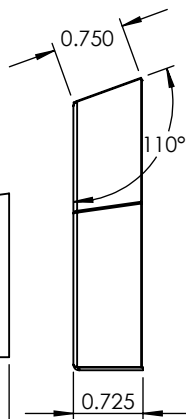
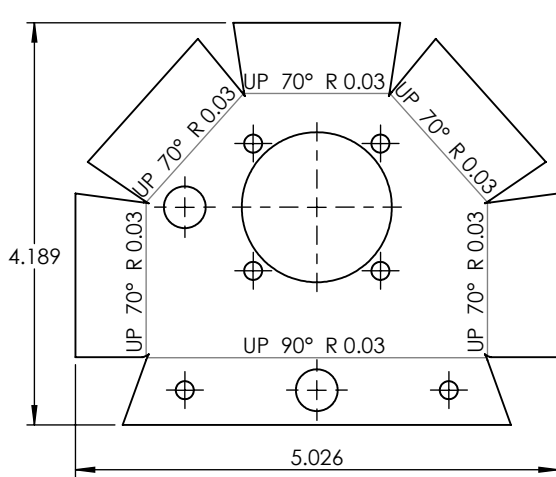
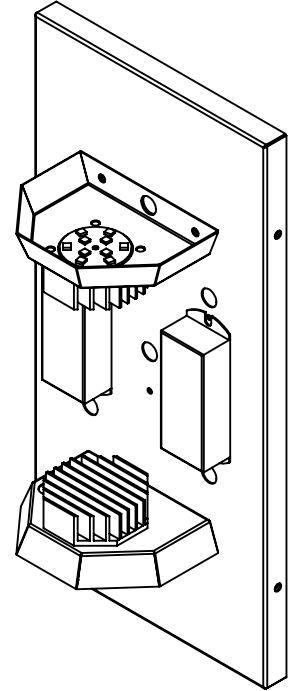
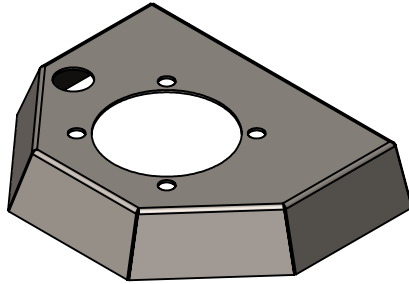
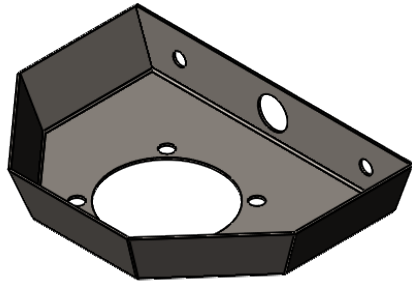

PROPRIETARY AND CONFIDENTIAL
 THE INFORMATION CONTAINED IN THIS DRAWING IS THE SOLE PROPERTY OF <INSERT COMPANY NAME HERE>. ANY REPRODUCTION IN PART OR AS A WHOLE WITHOUT THE WRITTEN PERMISSION OF <INSERT COMPANY NAME HERE> IS PROHIBITED.

		UNLESS OTHERWISE SPECIFIED:	NAME	DATE	22 GAUGE	
		DIMENSIONS ARE IN INCHES TOLERANCES: FRACTIONAL ± ANGULAR: MACH ± BEND ± TWO PLACE DECIMAL ± THREE PLACE DECIMAL ±	DRAWN		TITLE:	
		INTERPRET GEOMETRIC TOLERANCING PER:	CHECKED		HS-WANG-18L-TBR-A-TBL-WET-14"-35K	
		MATERIAL	ENG APPR.		SIZE	DWG. NO.
		FINISH	MFG APPR.		A	REV
NEXT ASSY	USED ON		Q.A.		SCALE: 1:2	WEIGHT:
APPLICATION	DO NOT SCALE DRAWING		COMMENTS:		SHEET 9 OF 9	

5

4

3

2

1