

ITEM NO.	PART NUMBER	DESCRIPTION	QTY.	CUT
1	SH-W-36-24W-TBR-WA-EMR-35K-BACKPLATE	22 GAUGE	1	
2	SH-W-36-24W-TBR-WA-EMR-35K-FRAME	22 GAUGE	1	
3	SH-W-36-24W-TBR-WA-EMR-35K-CAP	22 GAUGE	1	
4	SH-W-36-24W-TBR-WA-EMR-35K-EMR CAP	22 GAUGE	1	
5	SH-W-36-24W-TBR-WA-EMR-35K-FIREPLATE	22 GAUGE	1	
6	SH-W-36-24W-TBR-WA-EMR-35K-LED SPACER	22 GAUGE	1	
7	SH-W-36-24W-TBR-WA-EMR-35K-EMR BRACKET	22 GAUGE	1	
8	SH-W-36-24W-TBR-WA-EMR-35K-ACRYLIC	ACRYLIC	1	
9	EMR BUTTON	BUTTON	1	
10	ACE-G10-55-190-EMR PACK	DRIVER-BATTERY	1	
11	ESPEL VEL29070MVH-1	DRIVER	1	
12	AItailed_PN1010_RevD	LED	4	

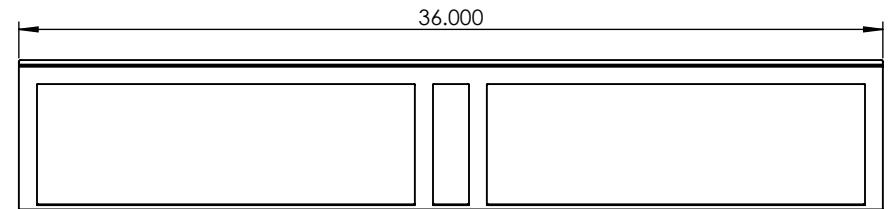

UNLESS OTHERWISE SPECIFIED:		NAME	DATE	TITLE:
DIMENSIONS ARE IN INCHES TOLERANCES: FRACTIONAL ± .003 ANGULAR: MACH ± .01 BEND ± TWO PLACE DECIMAL ± THREE PLACE DECIMAL ±.001		DRAWN		
INTERPRET GEOMETRIC TOLERANCING PER:		CHECKED		
MATERIAL		ENG APPR.		
FINISH		MFG APPR.		
APPLICATION		Q.A.		SIZE DWG. NO. REV
DO NOT SCALE DRAWING		COMMENTS:		A TICKET 26945
		SCALE: 1:8	WEIGHT:	SHEET 1 OF 6

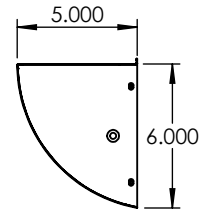
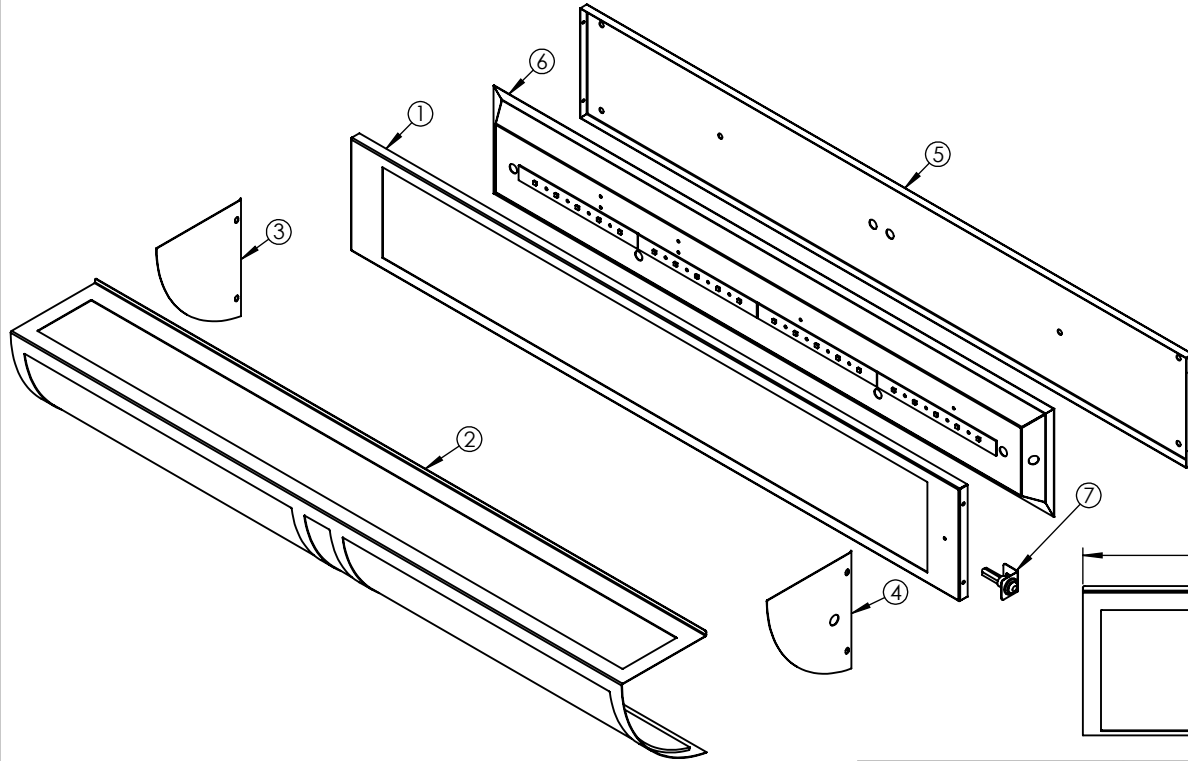
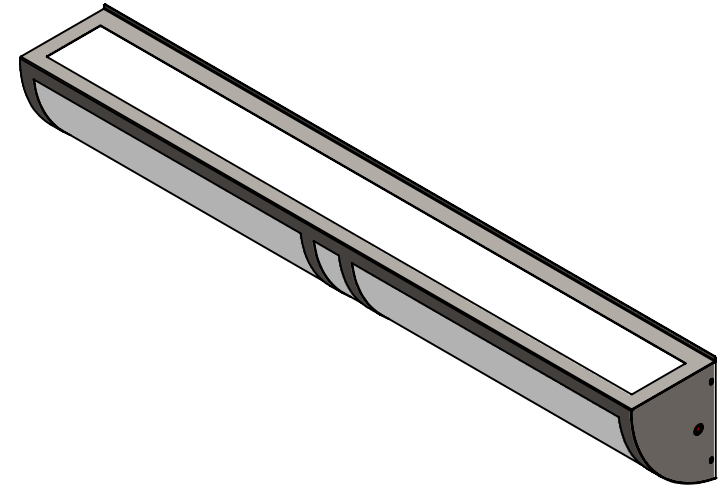

EVERGREEN LIGHTING

5

4

3

2

1

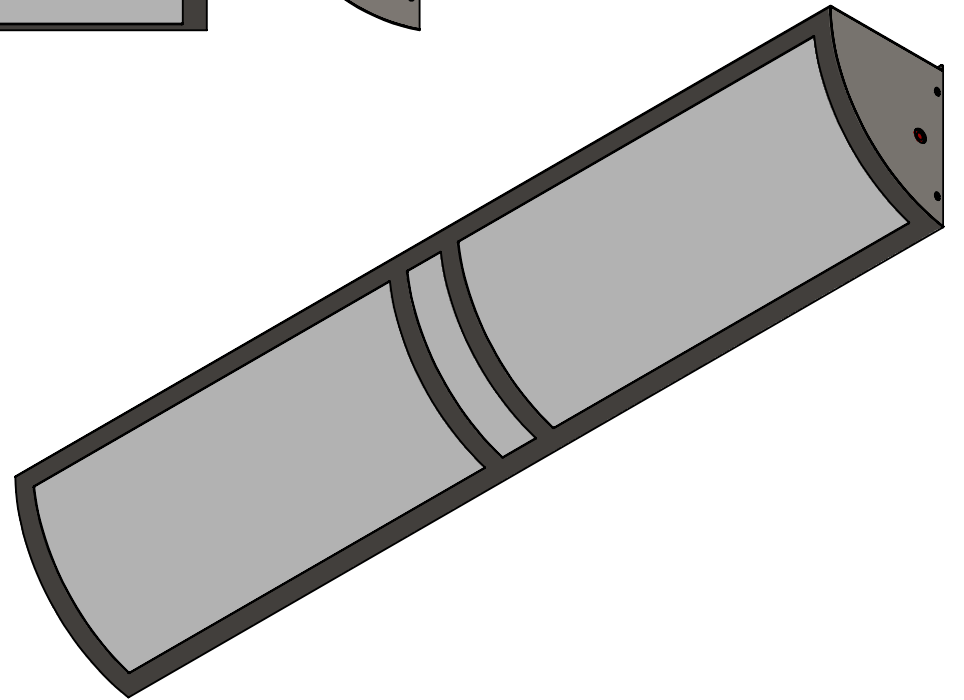
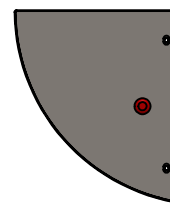
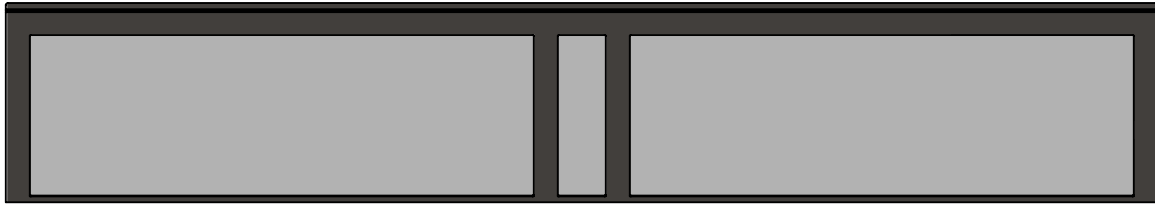
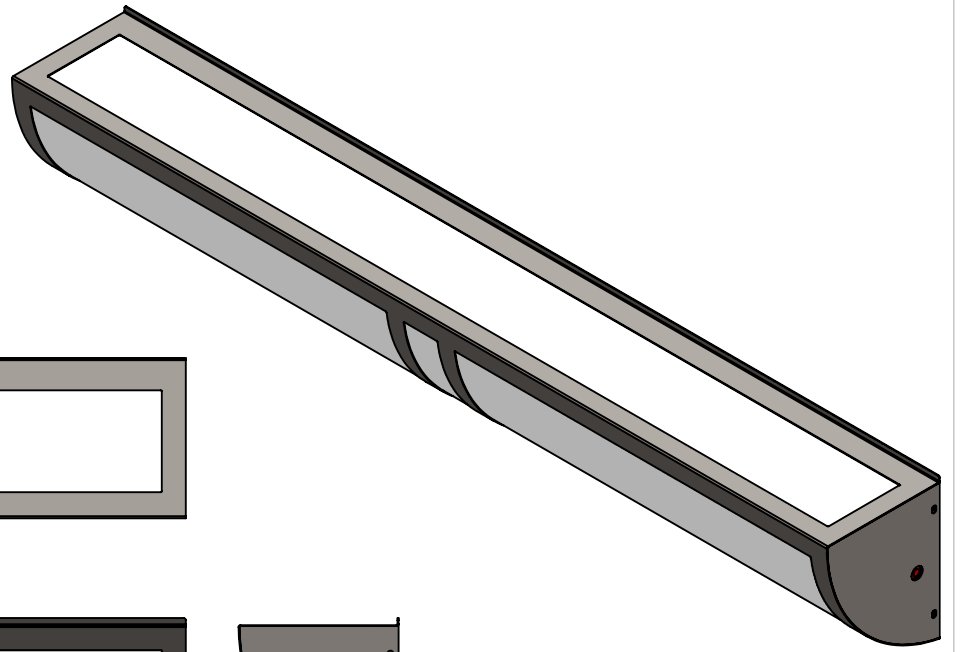

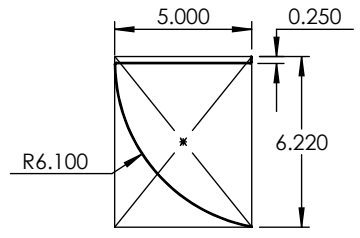
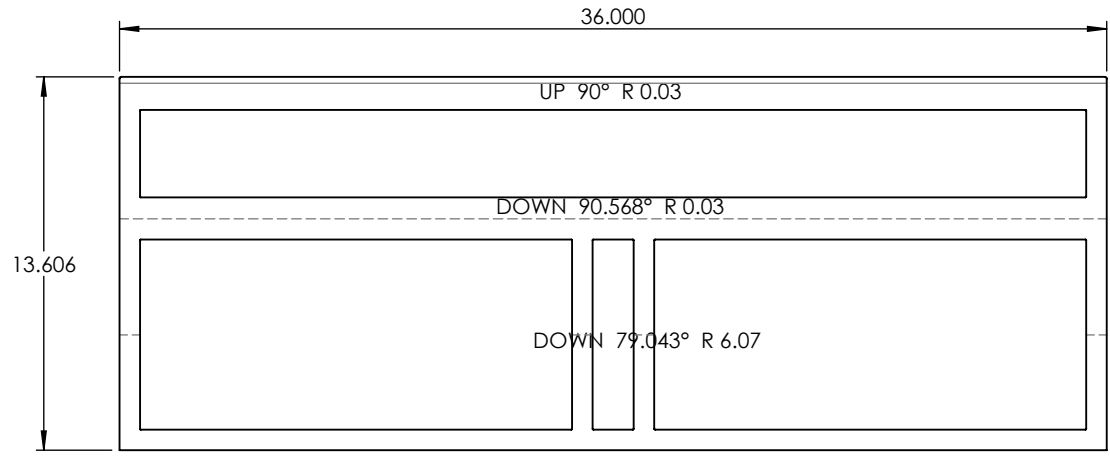
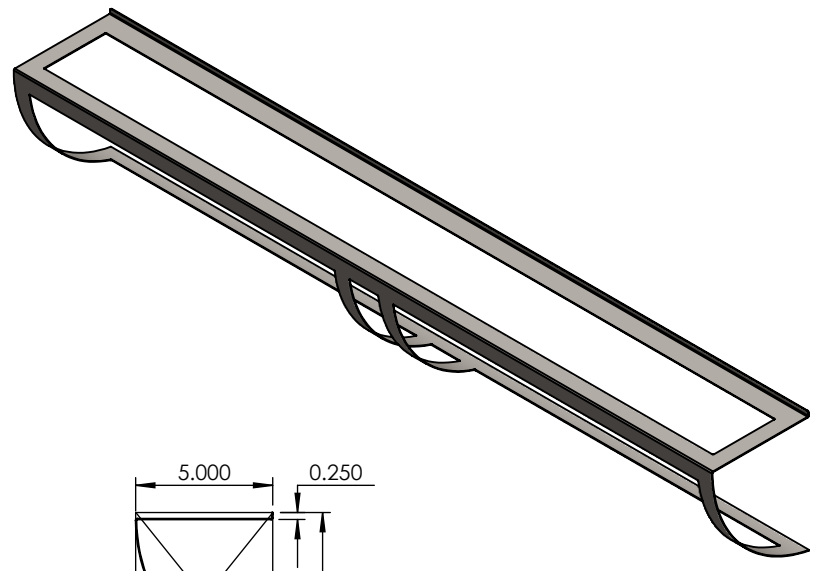
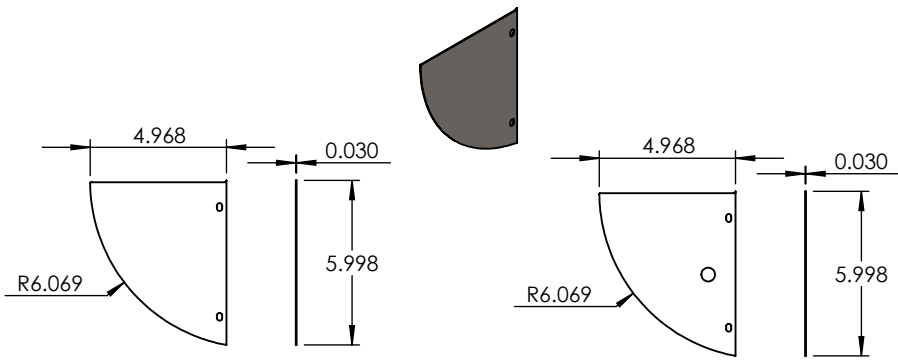

PROPRIETARY AND CONFIDENTIAL
 THE INFORMATION CONTAINED IN THIS DRAWING IS THE SOLE PROPERTY OF <INSERT COMPANY NAME HERE>. ANY REPRODUCTION IN PART OR AS A WHOLE WITHOUT THE WRITTEN PERMISSION OF <INSERT COMPANY NAME HERE> IS PROHIBITED.

		UNLESS OTHERWISE SPECIFIED:
		DIMENSIONS ARE IN INCHES
		TOLERANCES:
		FRACTIONAL ±
		ANGULAR: MACH ± BEND ±
		TWO PLACE DECIMAL ±
		THREE PLACE DECIMAL ±
		INTERPRET GEOMETRIC TOLERANCING PER:
		MATERIAL
		FINISH
NEXT ASSY	USED ON	
APPLICATION		DO NOT SCALE DRAWING

	NAME	DATE
	DRAWN	
	CHECKED	
	ENG APPR.	
	MFG APPR.	
	Q.A.	
	COMMENTS:	

22 GAUGE		
TITLE:		
SH-W-36-24W-TBR-WA-EMR-35K		
SIZE	DWG. NO.	REV
A		
SCALE: 1:7	WEIGHT:	SHEET 3 OF 6

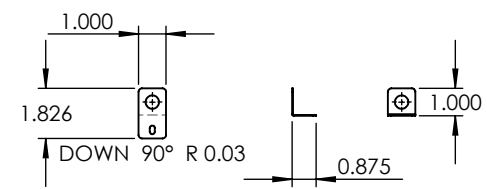
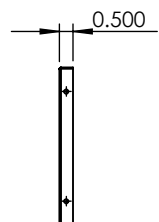
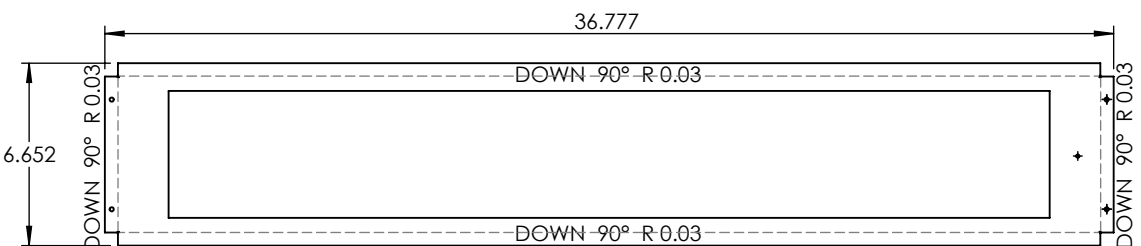
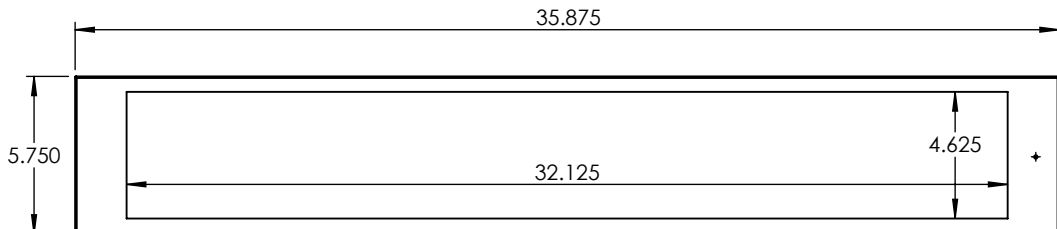
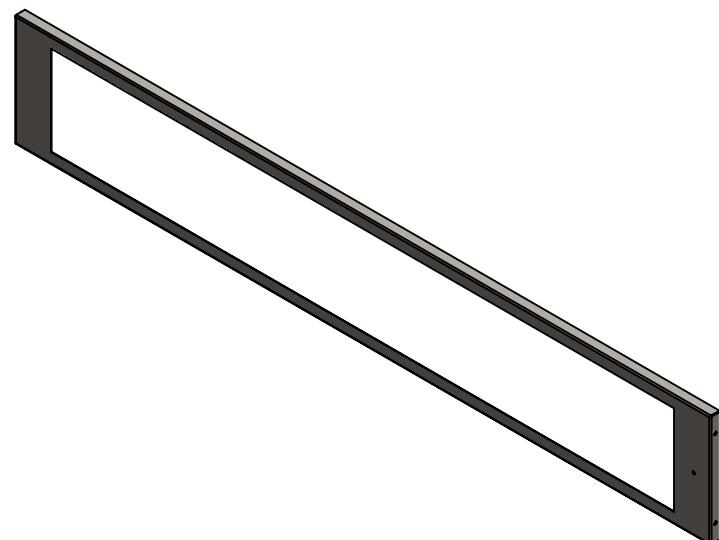

PROPRIETARY AND CONFIDENTIAL
 THE INFORMATION CONTAINED IN THIS DRAWING IS THE SOLE PROPERTY OF <INSERT COMPANY NAME HERE>. ANY REPRODUCTION IN PART OR AS A WHOLE WITHOUT THE WRITTEN PERMISSION OF <INSERT COMPANY NAME HERE> IS PROHIBITED.

		UNLESS OTHERWISE SPECIFIED:		NAME	DATE
		DIMENSIONS ARE IN INCHES	DRAWN		
		TOLERANCES:	CHECKED		
		FRACTIONAL ±	ENG APPR.		
		ANGULAR: MACH ± BEND ±	MFG APPR.		
		TWO PLACE DECIMAL ±	Q.A.		
		THREE PLACE DECIMAL ±	COMMENTS:		
		INTERPRET GEOMETRIC TOLERANCING PER:			
		MATERIAL			
	NEXT ASSY	USED ON			
		FINISH			
	APPLICATION	DO NOT SCALE DRAWING			

22 GAUGE		
TITLE:		
SH-W-36-24W-TBR-WA-EMR-35K		
SIZE	DWG. NO.	REV
A		
SCALE: 1:7	WEIGHT:	SHEET 4 OF 6

5

4

3

2

1

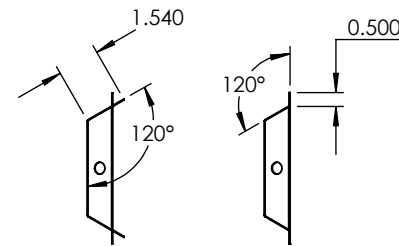
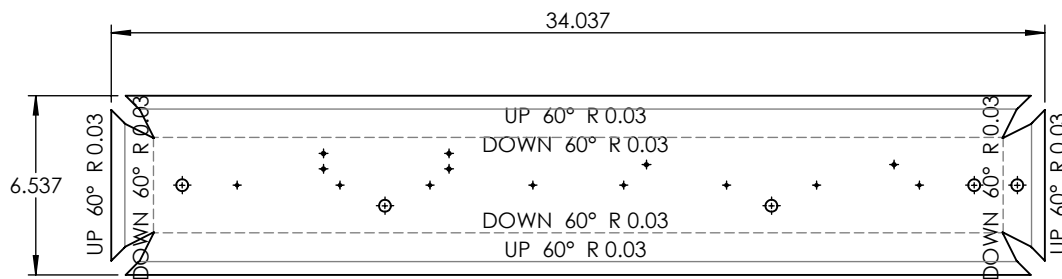
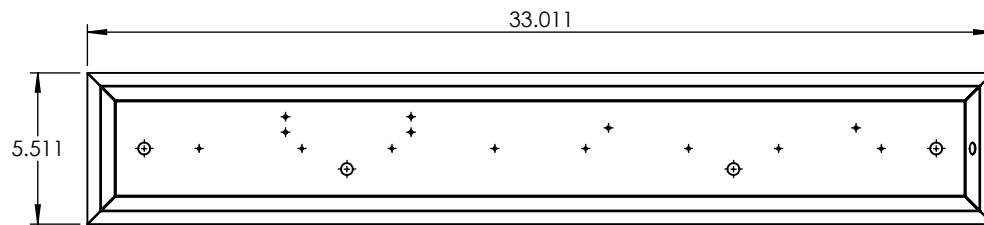
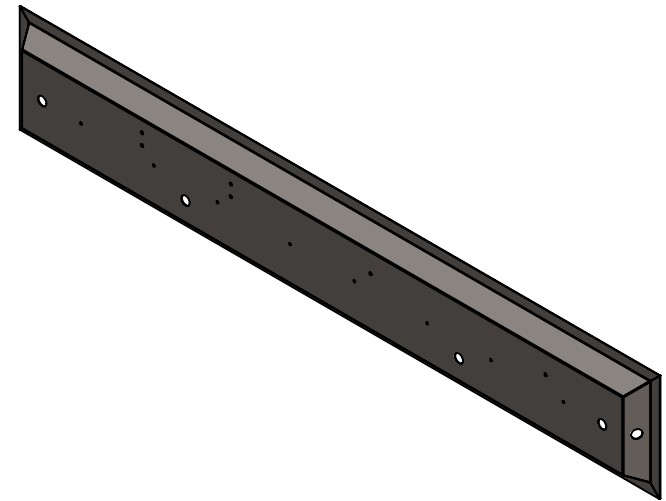

PROPRIETARY AND CONFIDENTIAL
 THE INFORMATION CONTAINED IN THIS DRAWING IS THE SOLE PROPERTY OF <INSERT COMPANY NAME HERE>. ANY REPRODUCTION IN PART OR AS A WHOLE WITHOUT THE WRITTEN PERMISSION OF <INSERT COMPANY NAME HERE> IS PROHIBITED.

		UNLESS OTHERWISE SPECIFIED:	NAME	DATE	22 GAUGE	
		DIMENSIONS ARE IN INCHES TOLERANCES: FRACTIONAL ± ANGULAR: MACH ± BEND ± TWO PLACE DECIMAL ± THREE PLACE DECIMAL ±	DRAWN			
		INTERPRET GEOMETRIC TOLERANCING PER:	CHECKED		SIZE DWG. NO. REV	
		MATERIAL	ENG APPR.			
		FINISH	MFG APPR.		SCALE: 1:7 WEIGHT: SHEET 5 OF 6	
NEXT ASSY	USED ON		Q.A.			
APPLICATION		DO NOT SCALE DRAWING	COMMENTS:			

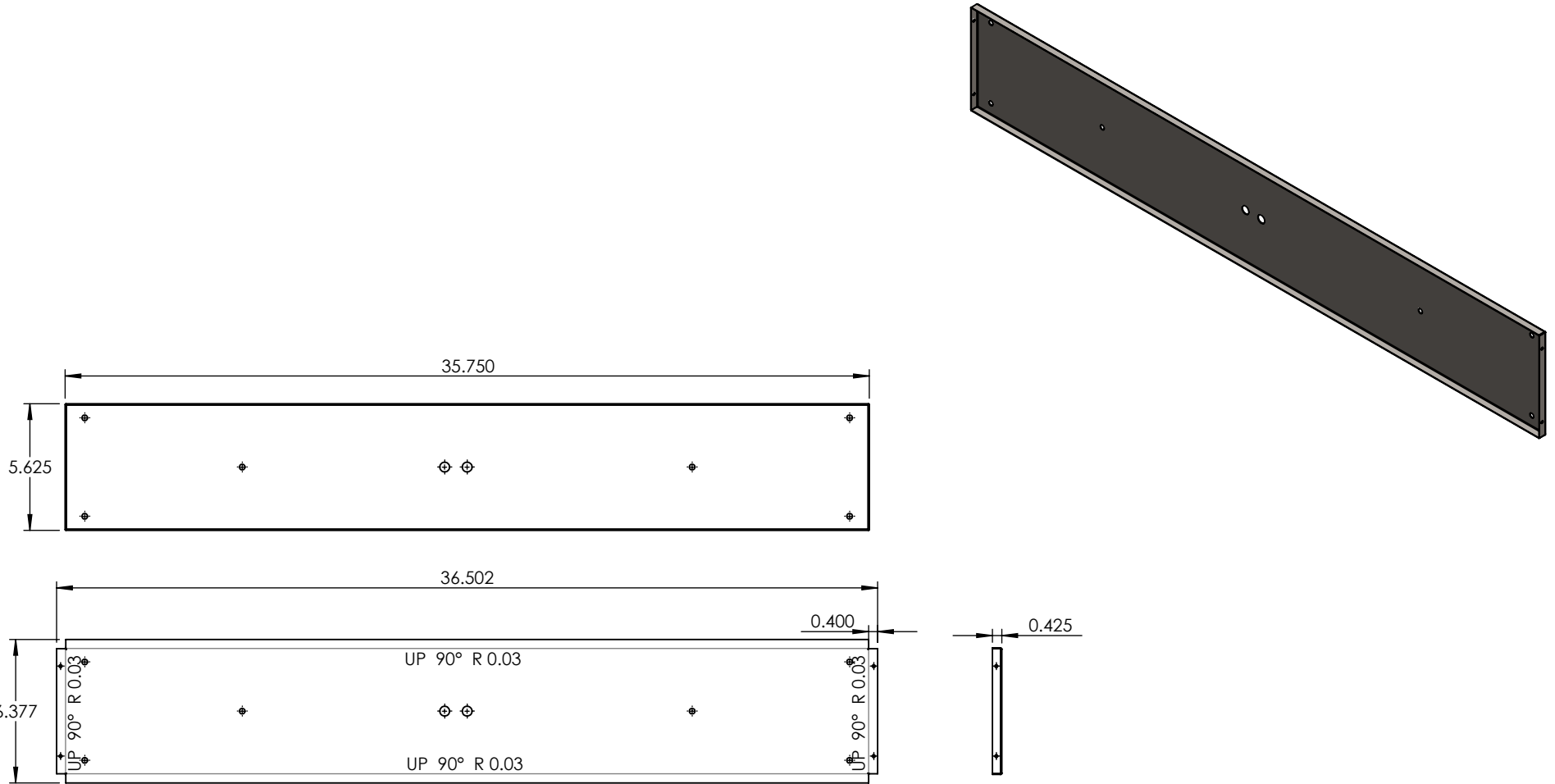

PROPRIETARY AND CONFIDENTIAL
 THE INFORMATION CONTAINED IN THIS DRAWING IS THE SOLE PROPERTY OF <INSERT COMPANY NAME HERE>. ANY REPRODUCTION IN PART OR AS A WHOLE WITHOUT THE WRITTEN PERMISSION OF <INSERT COMPANY NAME HERE> IS PROHIBITED.

		UNLESS OTHERWISE SPECIFIED:		NAME	DATE
		DIMENSIONS ARE IN INCHES	DRAWN		
		TOLERANCES:	CHECKED		
		FRACTIONAL ±	ENG APPR.		
		ANGULAR: MACH ± BEND ±	MFG APPR.		
		TWO PLACE DECIMAL ±	Q.A.		
		THREE PLACE DECIMAL ±	COMMENTS:		
		INTERPRET GEOMETRIC TOLERANCING PER:			
		MATERIAL			
NEXT ASSY	USED ON	FINISH			
APPLICATION		DO NOT SCALE DRAWING			

22 GAUGE		
TITLE: SH-W-36-24W-TBR-WA-EMR-35K		
SIZE A	DWG. NO.	REV
SCALE: 1:7	WEIGHT:	SHEET 6 OF 6