

ITEM NO.	PART NUMBER	DESCRIPTION	QTY.	CUT
1	GRA-W-15-24W-MBK-WF-TBL-WET-30K-BACKPLATE	22 GAUGE	1	
2	GRA-W-15-24W-MBK-WF-TBL-WET-30K-LED SPACER	22 GAUGE	1	
3	GRA-W-15-24W-MBK-WF-TBL-WET-30K-FIREPLATE	22 GAUGE	1	
4	GRA-W-15-24W-MBK-WF-TBL-WET-30K-LENS RAIL	22 GAUGE	2	
5	GRA-W-15-24W-MBK-WF-TBL-WET-30K-LENS CAP	22 GAUGE	2	
6	GRA-W-15-24W-MBK-WF-TBL-WET-30K-HORIZONTAL BAR	1/2"X1/4" ALUMINUM BAR	1	
7	GRA-W-15-24W-MBK-WF-TBL-WET-30K-VERTICAL BAR	1/2" SQUARE ALUMINUM BAR	1	
8	GRA-W-15-24W-MBK-WF-TBL-WET-30K-ACRYLIC	ACRYLIC	1	
9	EspenTECH_120277V_SKU808076	DRIVER	2	
10	AlfaLED_PN110B_RevC	LED	2	

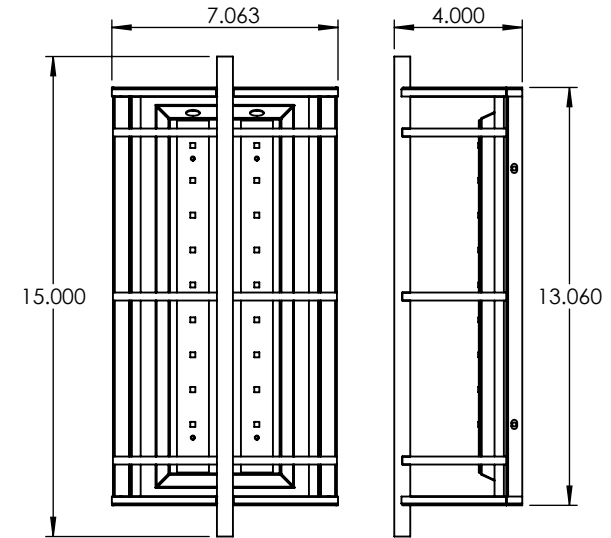
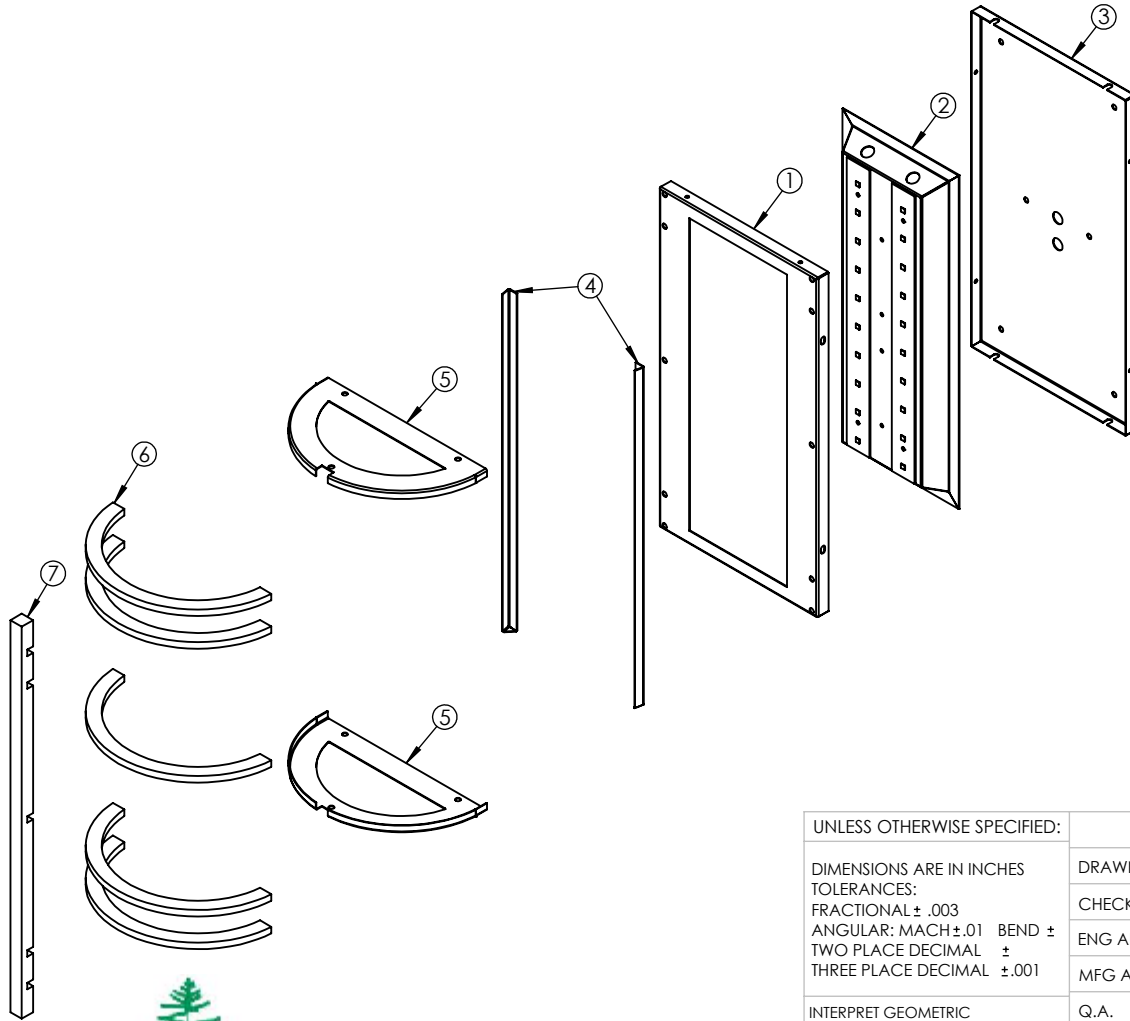
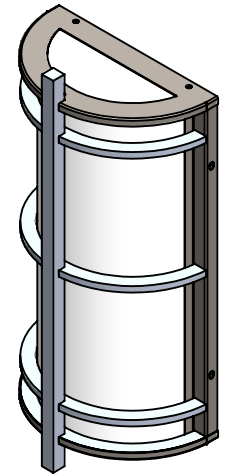
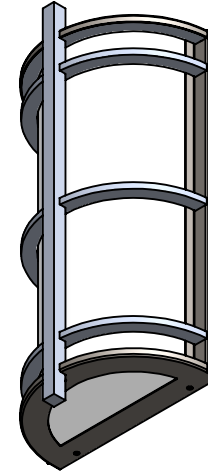

ALL BEND RADIUS .030"

APPLICATION

DO NOT SCALE DRAWING

UNLESS OTHERWISE SPECIFIED:

DIMENSIONS ARE IN INCHES  
 TOLERANCES:  
 FRACTIONAL ± .003  
 ANGULAR: MACH ± .01 BEND ±  
 TWO PLACE DECIMAL ±  
 THREE PLACE DECIMAL ±.001

INTERPRET GEOMETRIC  
 TOLERANCING PER:

MATERIAL

FINISH

NAME

DATE

DRAWN

CHECKED

ENG APPR.

MFG APPR.

Q.A.

COMMENTS:

TITLE:

GRA-W-15-24W-MBK-WF-TBL-WET-30K

SIZE DWG. NO.

**A** TICKET 27133

REV

SCALE: 1:6 WEIGHT:

SHEET 1 OF 8

5

4

3

2

1

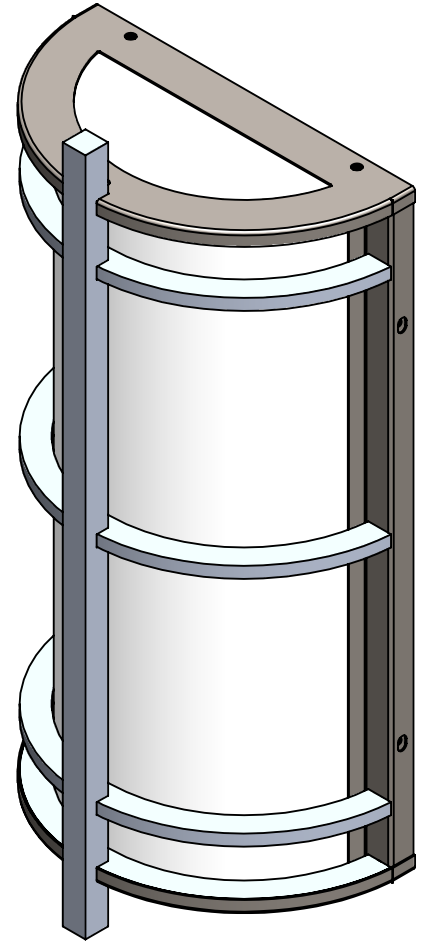
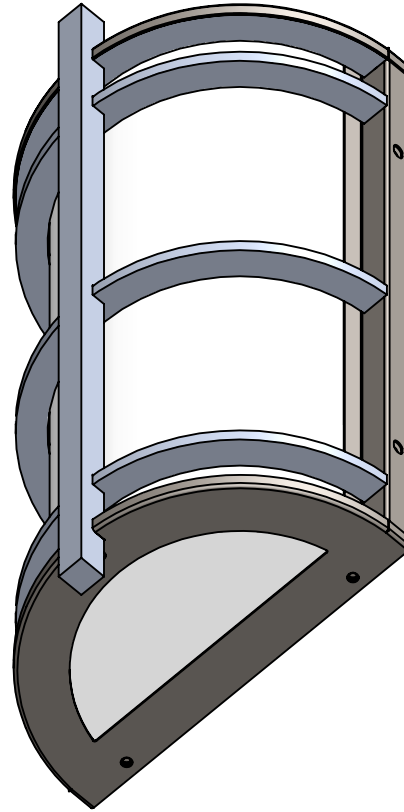
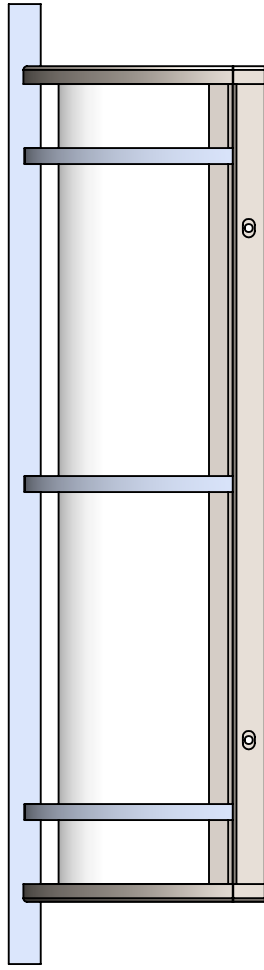
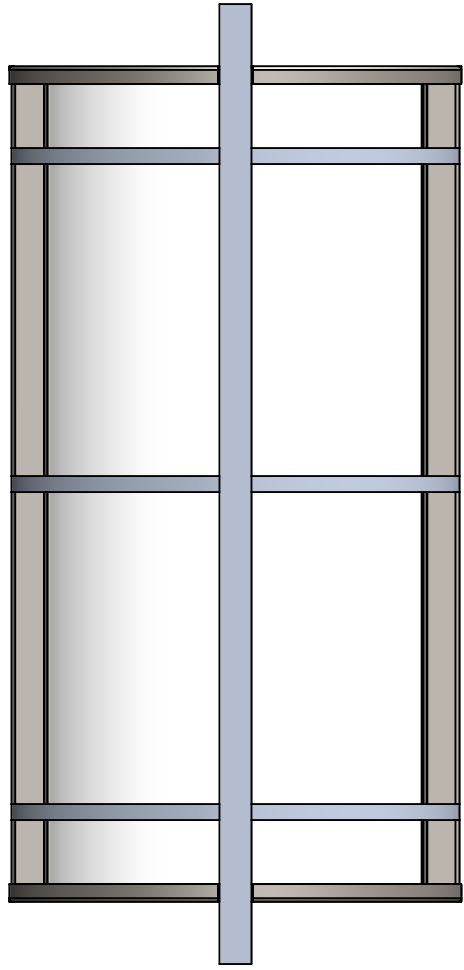

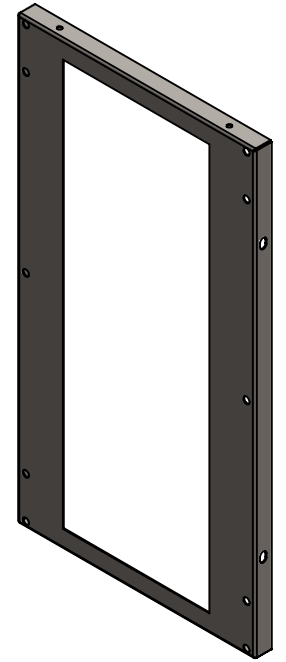
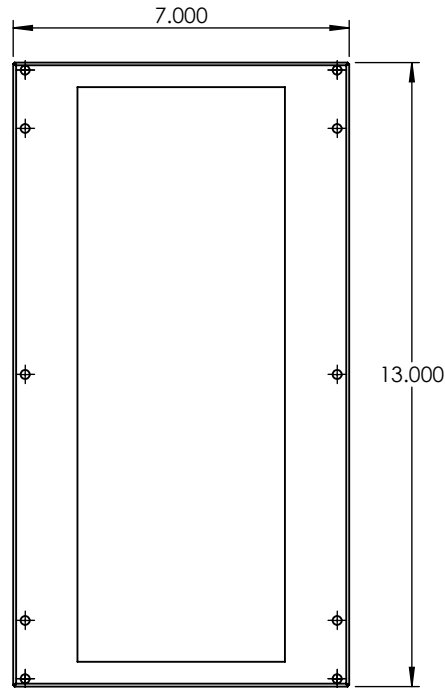
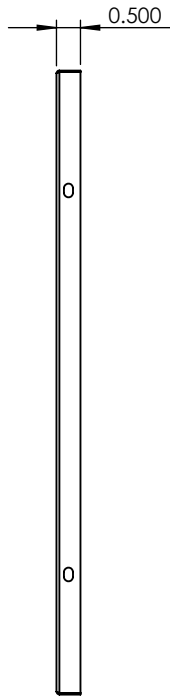
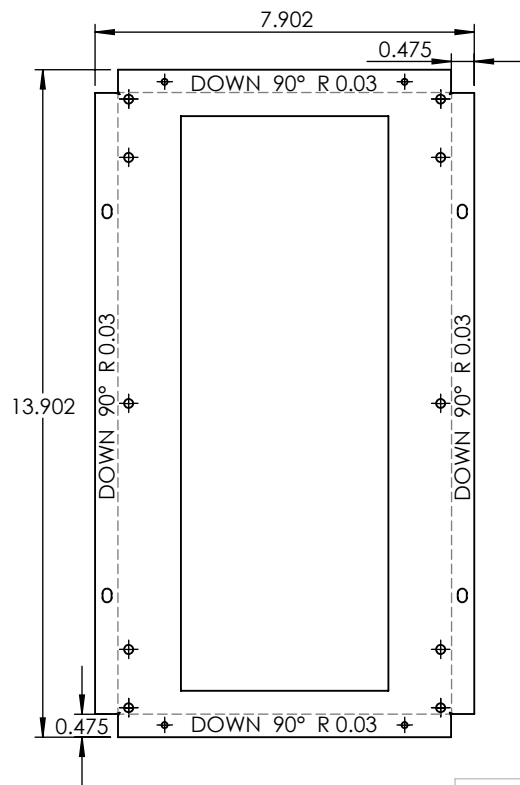

**PROPRIETARY AND CONFIDENTIAL**  
 THE INFORMATION CONTAINED IN THIS DRAWING IS THE SOLE PROPERTY OF <INSERT COMPANY NAME HERE>. ANY REPRODUCTION IN PART OR AS A WHOLE WITHOUT THE WRITTEN PERMISSION OF <INSERT COMPANY NAME HERE> IS PROHIBITED.

		UNLESS OTHERWISE SPECIFIED:	NAME	DATE	22 GAUGE	
		DIMENSIONS ARE IN INCHES TOLERANCES: FRACTIONAL ± ANGULAR: MACH ± BEND ± TWO PLACE DECIMAL ± THREE PLACE DECIMAL ±	DRAWN			
		INTERPRET GEOMETRIC TOLERANCING PER:	CHECKED		GRA-W-15-24W-MBK-WF-TBL-WET-30K	
		MATERIAL	ENG APPR.			
		FINISH	MFG APPR.		SIZE	DWG. NO.
NEXT ASSY	USED ON		Q.A.		<b>A</b>	REV
APPLICATION		DO NOT SCALE DRAWING	COMMENTS:		SCALE: 1:4	WEIGHT:
					SHEET 3 OF 8	

5

4

3

2

1

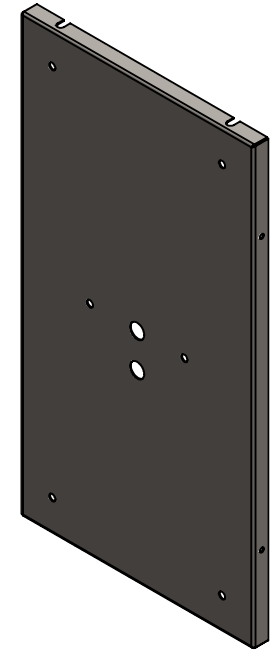
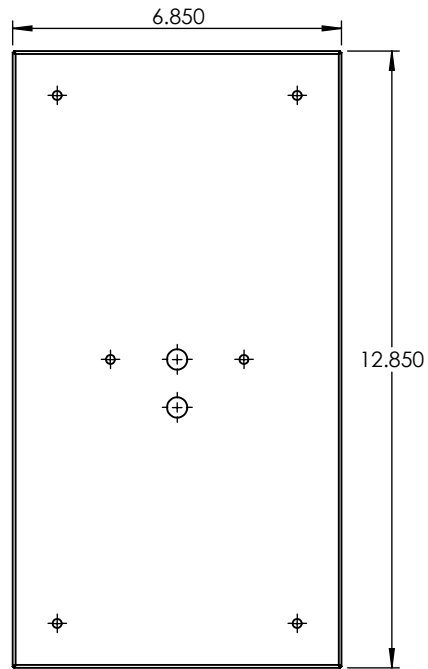
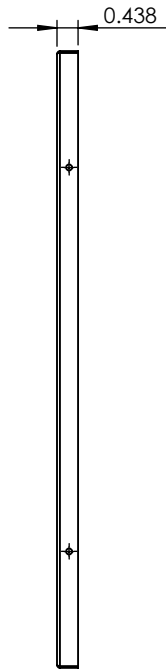
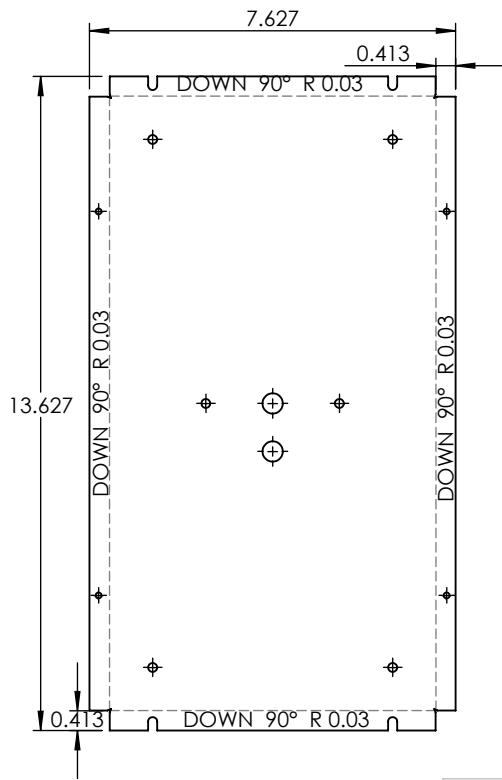

**PROPRIETARY AND CONFIDENTIAL**  
 THE INFORMATION CONTAINED IN THIS DRAWING IS THE SOLE PROPERTY OF <INSERT COMPANY NAME HERE>. ANY REPRODUCTION IN PART OR AS A WHOLE WITHOUT THE WRITTEN PERMISSION OF <INSERT COMPANY NAME HERE> IS PROHIBITED.

		UNLESS OTHERWISE SPECIFIED:	NAME	DATE
		DIMENSIONS ARE IN INCHES	DRAWN	
		TOLERANCES:	CHECKED	
		FRACTIONAL ±	ENG APPR.	
		ANGULAR: MACH ± BEND ±	MFG APPR.	
		TWO PLACE DECIMAL ±	Q.A.	
		THREE PLACE DECIMAL ±	COMMENTS:	
		INTERPRET GEOMETRIC TOLERANCING PER:		
		MATERIAL		
		FINISH		
NEXT ASSY	USED ON			
APPLICATION	DO NOT SCALE DRAWING			

22 GAUGE		
TITLE:		
GRA-W-15-24W-MBK-WF-TBL-WET-30K		
SIZE	DWG. NO.	REV
<b>A</b>		
SCALE: 1:4	WEIGHT:	SHEET 4 OF 8

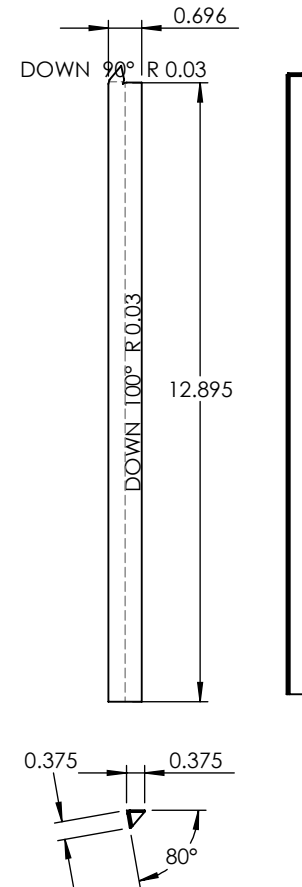
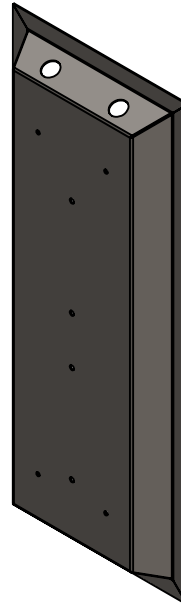
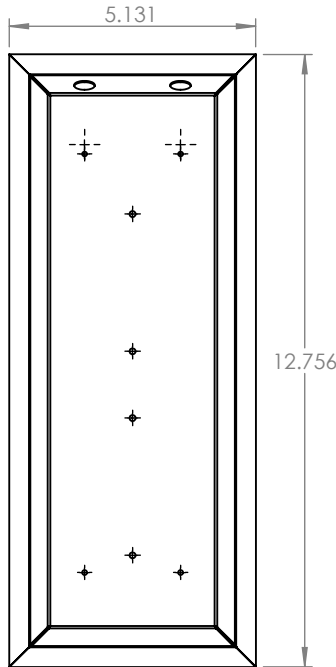
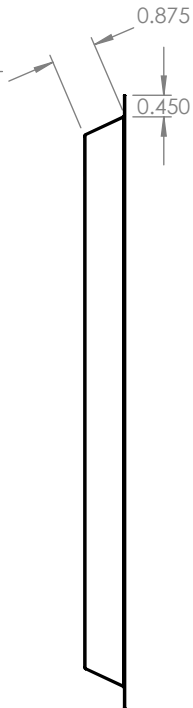
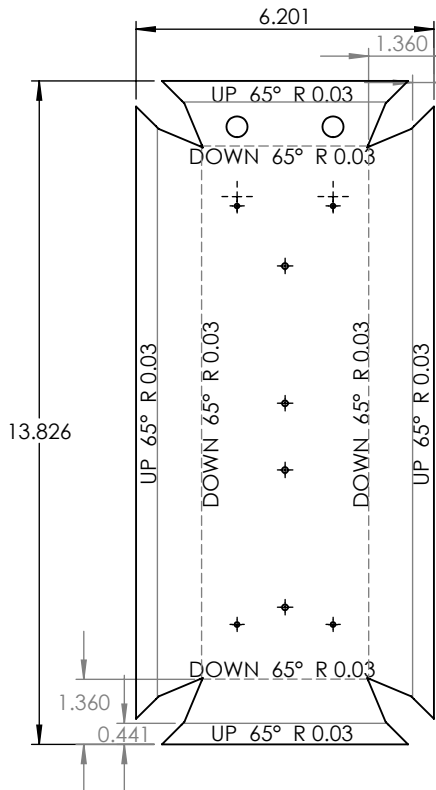

**PROPRIETARY AND CONFIDENTIAL**  
 THE INFORMATION CONTAINED IN THIS DRAWING IS THE SOLE PROPERTY OF <INSERT COMPANY NAME HERE>. ANY REPRODUCTION IN PART OR AS A WHOLE WITHOUT THE WRITTEN PERMISSION OF <INSERT COMPANY NAME HERE> IS PROHIBITED.

		UNLESS OTHERWISE SPECIFIED:	NAME	DATE
		DIMENSIONS ARE IN INCHES	DRAWN	
		TOLERANCES:	CHECKED	
		FRACTIONAL ±	ENG APPR.	
		ANGULAR: MACH ± BEND ±	MFG APPR.	
		TWO PLACE DECIMAL ±	Q.A.	
		THREE PLACE DECIMAL ±	COMMENTS:	
		INTERPRET GEOMETRIC TOLERANCING PER:		
		MATERIAL		
NEXT ASSY	USED ON	FINISH		
APPLICATION		DO NOT SCALE DRAWING		

22 GAUGE		
TITLE:		
GRA-W-15-24W-MBK-WF-TBL-WET-30K		
SIZE	DWG. NO.	REV
<b>A</b>		
SCALE: 1:4	WEIGHT:	SHEET 5 OF 8

5

4

3

2

1

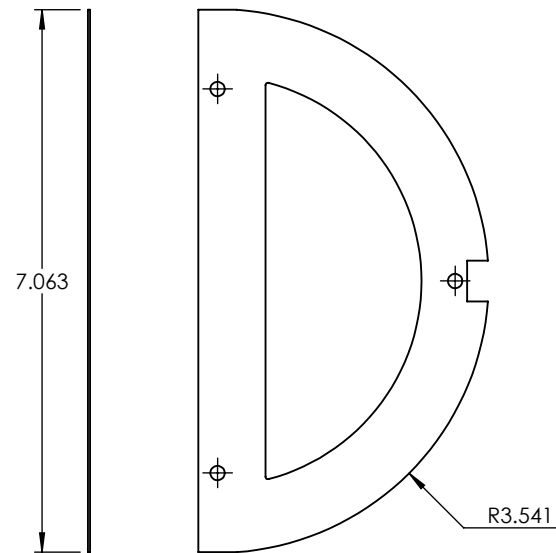
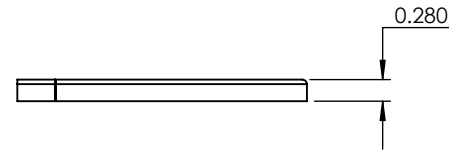
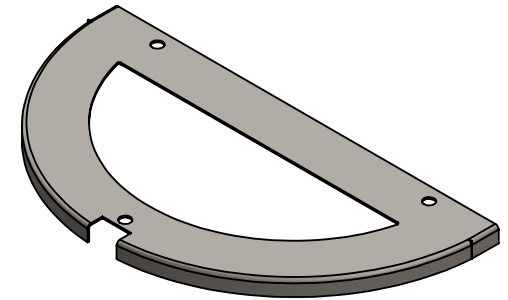

**PROPRIETARY AND CONFIDENTIAL**  
 THE INFORMATION CONTAINED IN THIS DRAWING IS THE SOLE PROPERTY OF <INSERT COMPANY NAME HERE>. ANY REPRODUCTION IN PART OR AS A WHOLE WITHOUT THE WRITTEN PERMISSION OF <INSERT COMPANY NAME HERE> IS PROHIBITED.

		UNLESS OTHERWISE SPECIFIED:		NAME	DATE	22 GAUGE	
		DIMENSIONS ARE IN INCHES	DRAWN			TITLE:	
		TOLERANCES:	CHECKED			GRA-W-15-24W-MBK-WF-TBL-WET-30K	
		FRACTIONAL ±	ENG APPR.			SIZE	DWG. NO.
		ANGULAR: MACH ± BEND ±	MFG APPR.			<b>A</b>	REV
		TWO PLACE DECIMAL ±	Q.A.			SCALE: 1:2.5 WEIGHT:	
		THREE PLACE DECIMAL ±	COMMENTS:			SHEET 6 OF 8	
		INTERPRET GEOMETRIC TOLERANCING PER:					
		MATERIAL					
		FINISH					
NEXT ASSY	USED ON	APPLICATION	DO NOT SCALE DRAWING				

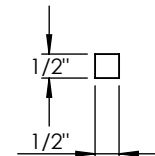
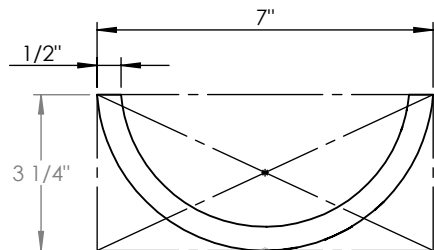
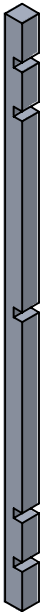
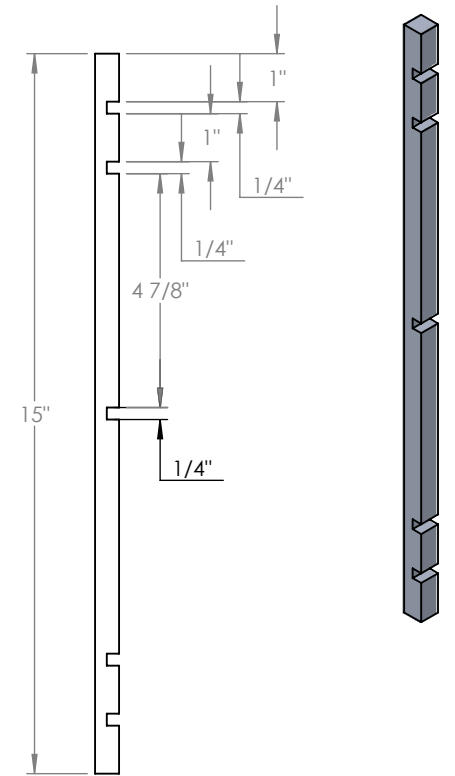
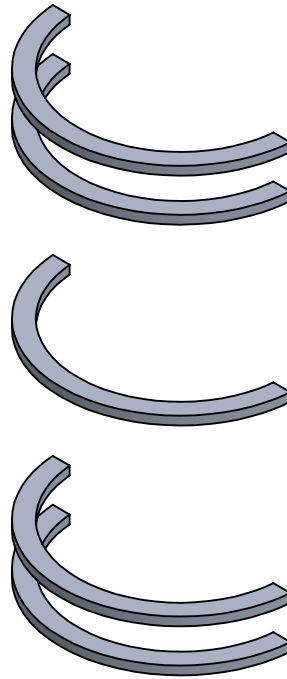
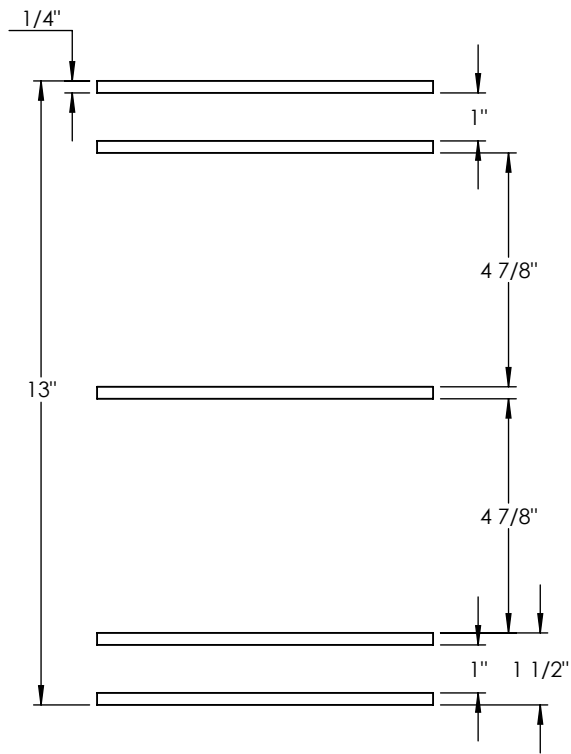

UNLESS OTHERWISE SPECIFIED:		NAME	DATE	1/2" SQUARE ALUMINUM BAR VERTICAL 1/2X1/4 HORIZONTAL	
DIMENSIONS ARE IN INCHES		DRAWN		TITLE:	
TOLERANCES:		CHECKED		GRA-W-15-24W-MBK-WF-TBL-WET-30K	
FRACTIONAL ±		ENG APPR.		SIZE DWG. NO. REV	
ANGULAR: MACH ± BEND ±		MFG APPR.		SCALE: 1:4 WEIGHT: SHEET 7 OF 8	
TWO PLACE DECIMAL ±		Q.A.			
THREE PLACE DECIMAL ±		COMMENTS:			
INTERPRET GEOMETRIC TOLERANCING PER:					
MATERIAL					
FINISH					
NEXT ASSY	USED ON				
APPLICATION		DO NOT SCALE DRAWING			

**PROPRIETARY AND CONFIDENTIAL**  
 THE INFORMATION CONTAINED IN THIS DRAWING IS THE SOLE PROPERTY OF <INSERT COMPANY NAME HERE>. ANY REPRODUCTION IN PART OR AS A WHOLE WITHOUT THE WRITTEN PERMISSION OF <INSERT COMPANY NAME HERE> IS PROHIBITED.

