

**EVERGREEN LIGHTING**

ALL BEND RADIUS .030"

UNLESS OTHERWISE SPECIFIED:

DIMENSIONS ARE IN INCHES  
 TOLERANCES:  
 FRACTIONAL ± .003  
 ANGULAR: MACH ± .01 BEND ±  
 TWO PLACE DECIMAL ±  
 THREE PLACE DECIMAL ± .001

INTERPRET GEOMETRIC  
 TOLERANCING PER:

MATERIAL

FINISH

DO NOT SCALE DRAWING

NAME

DATE

DRAWN

CHECKED

ENG APPR.

MFG APPR.

Q.A.

COMMENTS:

TITLE:

GP-BOL-60''-DB-20W-MBK-CFA-40K

SIZE DWG. NO.

REV

**A** TICKET 27414

SCALE: 1:12 WEIGHT:

SHEET 1 OF 11

5

4

3

2

1

ITEM NO.	PART NUMBER	DESCRIPTION	QTY.	CUT
1	GP-BOL-60"-DB-20W-MBK-CFA-40K-4" CYLINDER POST	4" ALUMINUM TUBE POST	1	
2	GP-BOL-60"-DB-20W-MBK-CFA-40K-4" FITTER BRACKET	ALUMINUM 0.250" PLATE	1	
3	GP-BOL-60"-DB-20W-MBK-CFA-40K-CYLINDER CAP	ALUMINUM 0.250" PLATE	1	
4	GP-BOL-60"-DB-20W-MBK-CFA-40K-SPUN TOP CAP	SPUN ALUMINUM 0.080"	1	
5	GP-BOL-60"-DB-20W-MBK-CFA-40K-SPUN CONE HEAD	SPUN ALUMINUM 0.125"	1	
6	GP-BOL-60"-DB-20W-MBK-CFA-40K-MOUNTING BRACKET	ALUMINUM 0.0635"	1	
7	GP-BOL-60"-DB-20W-MBK-CFA-40K-LED PLATE	ALUMINUM 0.0625"	1	
8	GP-BOL-60"-DB-20W-MBK-CFA-40K-DRIVER BRACKET	ALUMINUM 0.0635"	1	
9	GP-BOL-60"-DB-20W-MBK-CFA-40K-ARM TUBE	1/2" X 1" ALUMINUM TUBE	2	
10	GP-BOL-60"-DB-20W-MBK-CFA-40K-ACRYLIC	ACRYLIC	1	
11	GP-BOL-60"-DB-20W-MBK-CFA-40K-NIPPLE	NIPPLE	2	
12	Altal LED PN1019 SHIM PLATE	ALUMINUM 0.125" PLATE	2	
13	ESPEN VEL29070MVH-1	DRIVER	1	
14	Altal LED PN1019 RevC	LED	2	
15	8-32-0.5 SS Hex Drive Flat Head	8-32 FLAT HEAD SCREW	4	
16	8-32 SS Hex Drive Flat Head	8-32 FLAT HEAD SCREW	4	
17	90272A194	#8-32 SCREW	4	

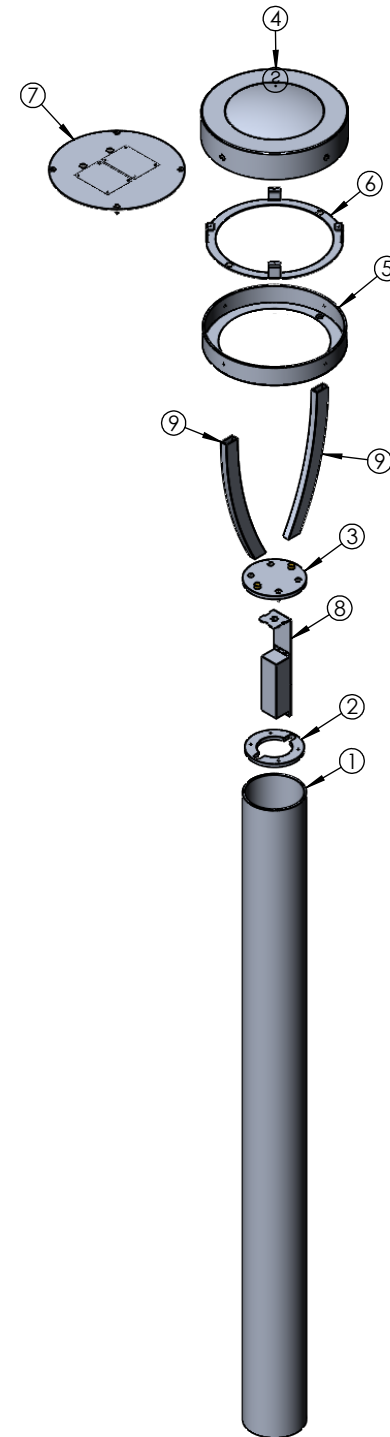

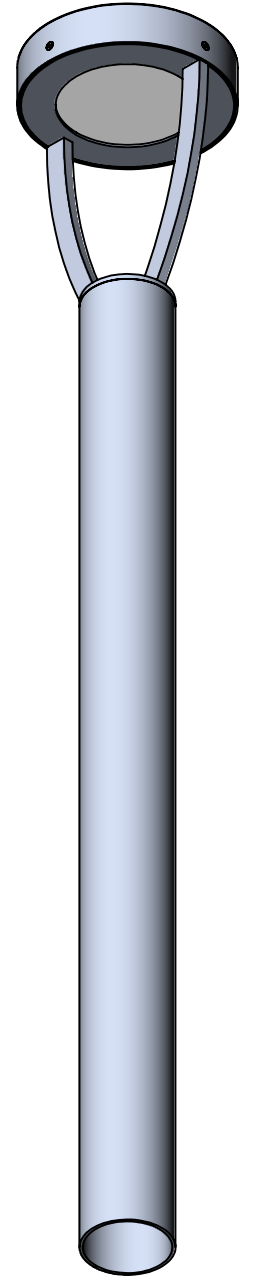
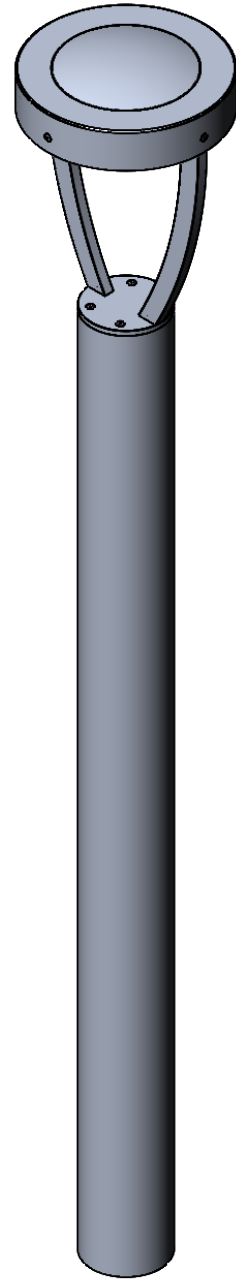
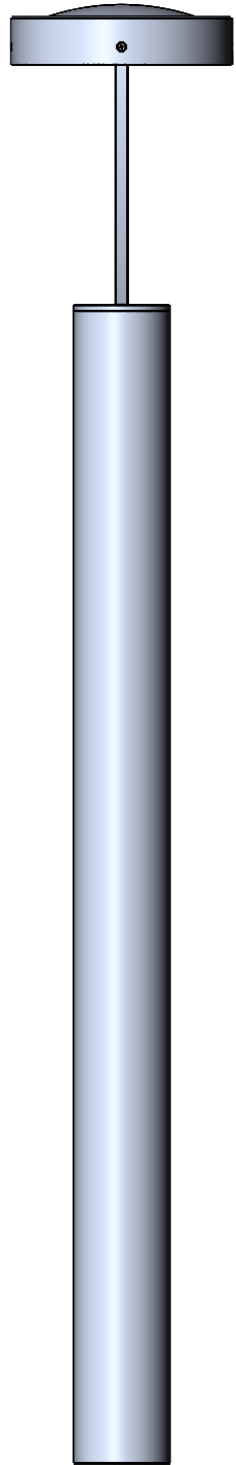
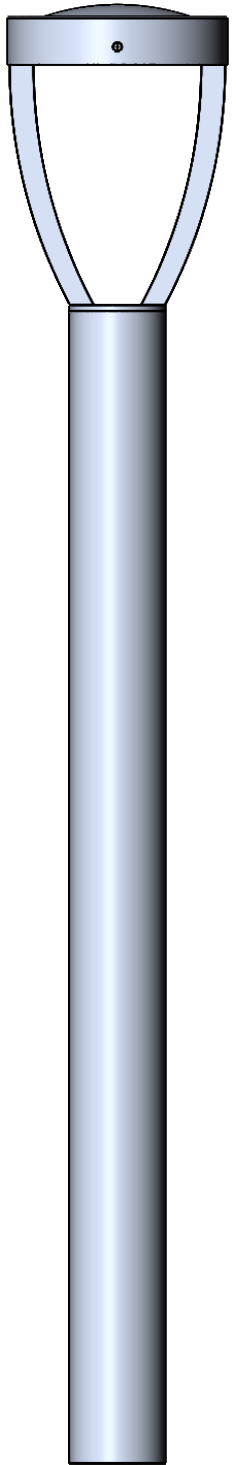

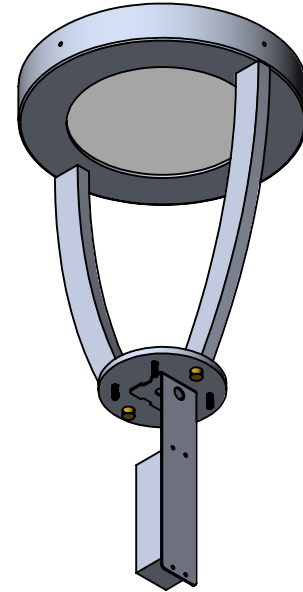
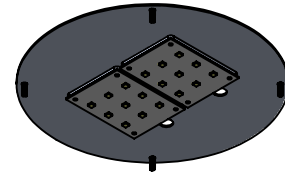
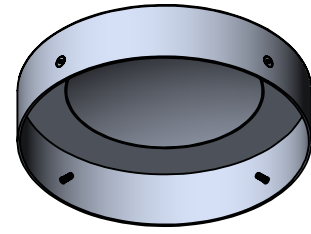
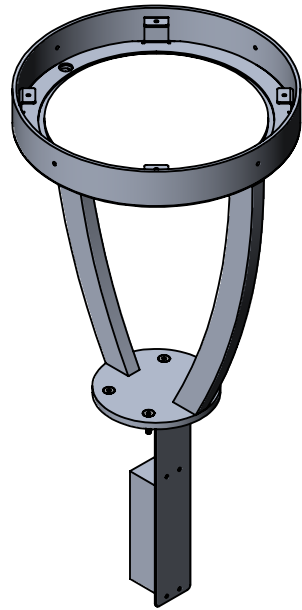
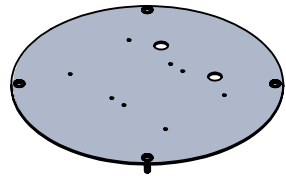
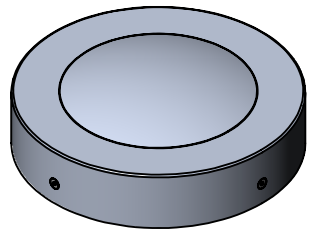

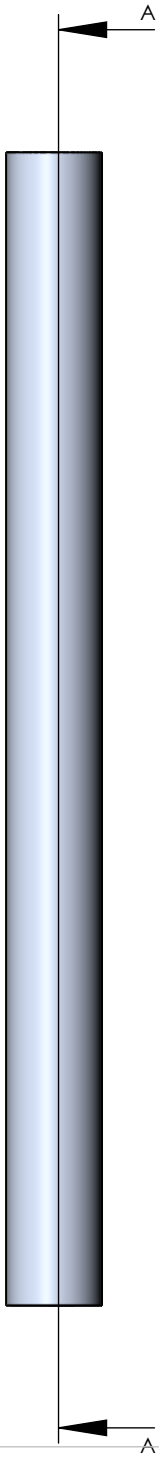

SECTION A-A



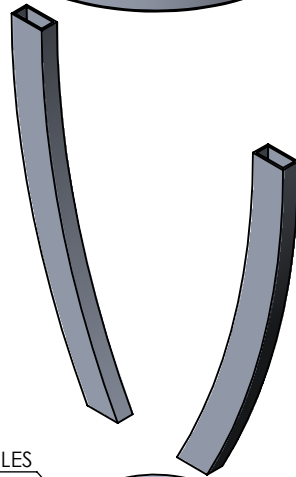

CHAMFERED HOLES

TAPPED HOLES FOR NIPPLE,  
EXTENDS 1/2" ON BOTH SIDES OF PLATE

WELDED FROM CENTER  
OF PLATE

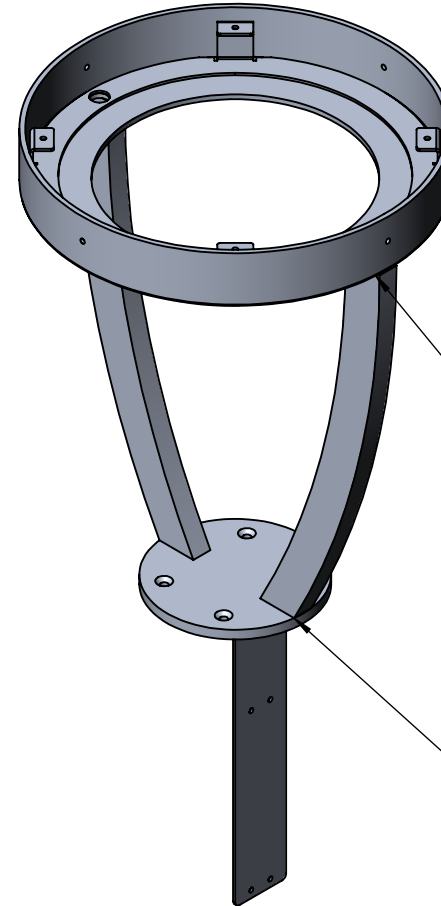

TUBES NEED TO BE  
WELDED ALL AROUND

TUBES NEED TO BE  
WELDED ALL AROUND

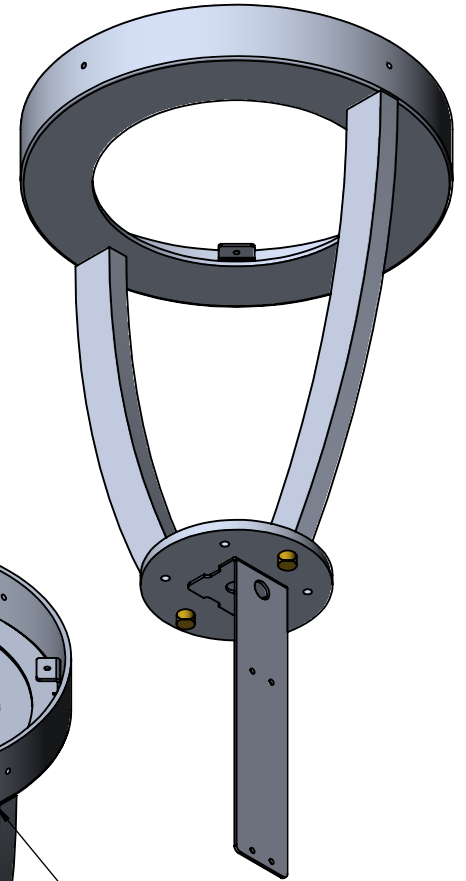

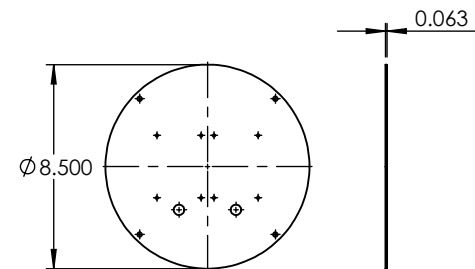
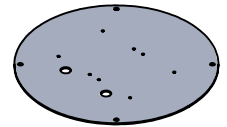
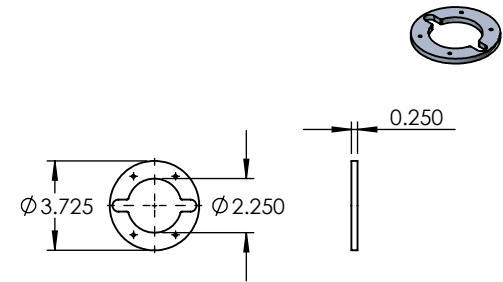
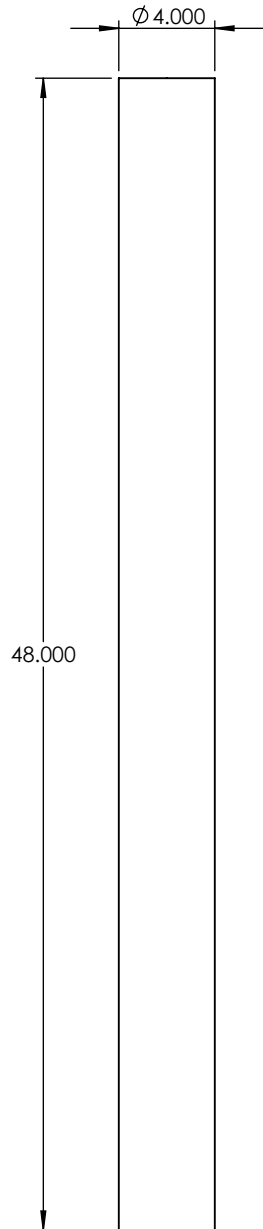

**PROPRIETARY AND CONFIDENTIAL**  
 THE INFORMATION CONTAINED IN THIS DRAWING IS THE SOLE PROPERTY OF <INSERT COMPANY NAME HERE>. ANY REPRODUCTION IN PART OR AS A WHOLE WITHOUT THE WRITTEN PERMISSION OF <INSERT COMPANY NAME HERE> IS PROHIBITED.

		UNLESS OTHERWISE SPECIFIED:		NAME	DATE
		DIMENSIONS ARE IN INCHES	DRAWN		
		TOLERANCES:	CHECKED		
		FRACTIONAL ±	ENG APPR.		
		ANGULAR: MACH ± BEND ±	MFG APPR.		
		TWO PLACE DECIMAL ±	Q.A.		
		THREE PLACE DECIMAL ±	COMMENTS:		
		INTERPRET GEOMETRIC TOLERANCING PER:			
		MATERIAL			
NEXT ASSY	USED ON	FINISH			
APPLICATION		DO NOT SCALE DRAWING			

**4" ALUMINUM TUBE POST**

TITLE:  
**GP-BOL-60"-DB-20W-MBK-CFA-40K**

SIZE	DWG. NO.	REV
<b>A</b>		

SCALE: 1:8	WEIGHT:	SHEET 7 OF 11
------------	---------	---------------

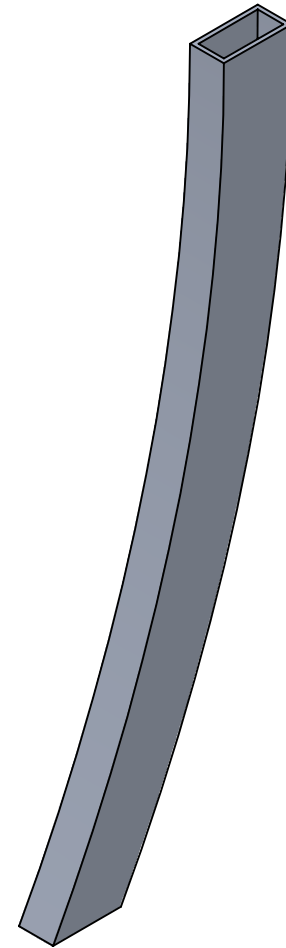
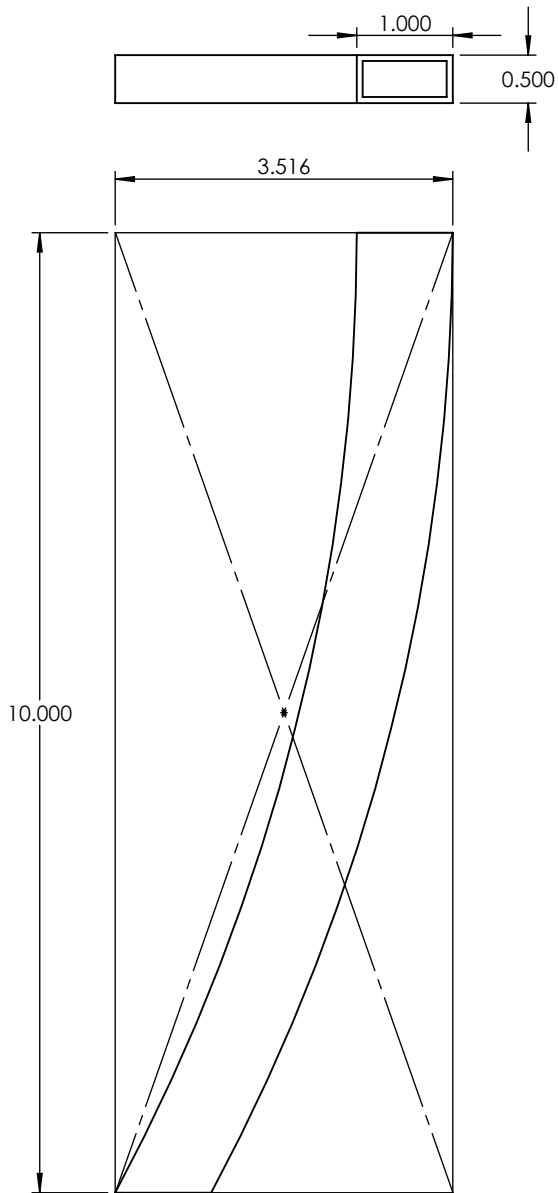

UNLESS OTHERWISE SPECIFIED:		NAME	DATE	1/2" X 1" ALUMINUM TUBE		
DIMENSIONS ARE IN INCHES TOLERANCES: FRACTIONAL ± ANGULAR: MACH ± BEND ± TWO PLACE DECIMAL ± THREE PLACE DECIMAL ±		DRAWN				TITLE:
INTERPRET GEOMETRIC TOLERANCING PER:		CHECKED		GP-BOL-60"-DB-20W-MBK-CFA-40K		
		ENG APPR.				
		MFG APPR.				
MATERIAL		Q.A.		SIZE DWG. NO. REV		
FINISH		COMMENTS:		A		
DO NOT SCALE DRAWING				SCALE: 1:2	WEIGHT:	SHEET 8 OF 11

**PROPRIETARY AND CONFIDENTIAL**  
 THE INFORMATION CONTAINED IN THIS DRAWING IS THE SOLE PROPERTY OF <INSERT COMPANY NAME HERE>. ANY REPRODUCTION IN PART OR AS A WHOLE WITHOUT THE WRITTEN PERMISSION OF <INSERT COMPANY NAME HERE> IS PROHIBITED.

NEXT ASSY	USED ON
APPLICATION	



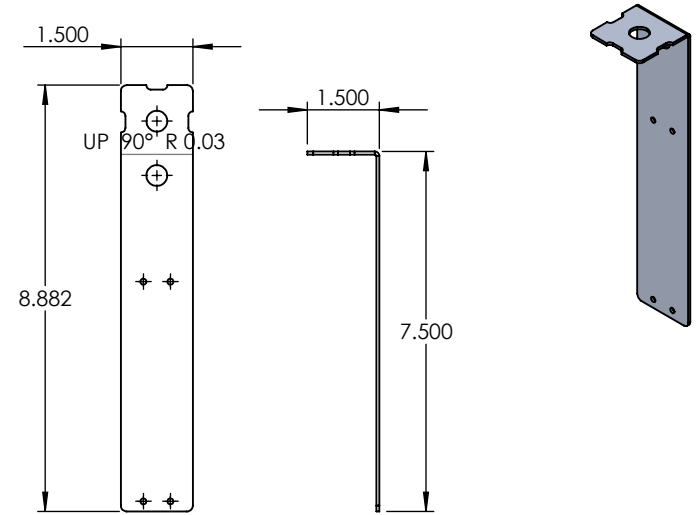
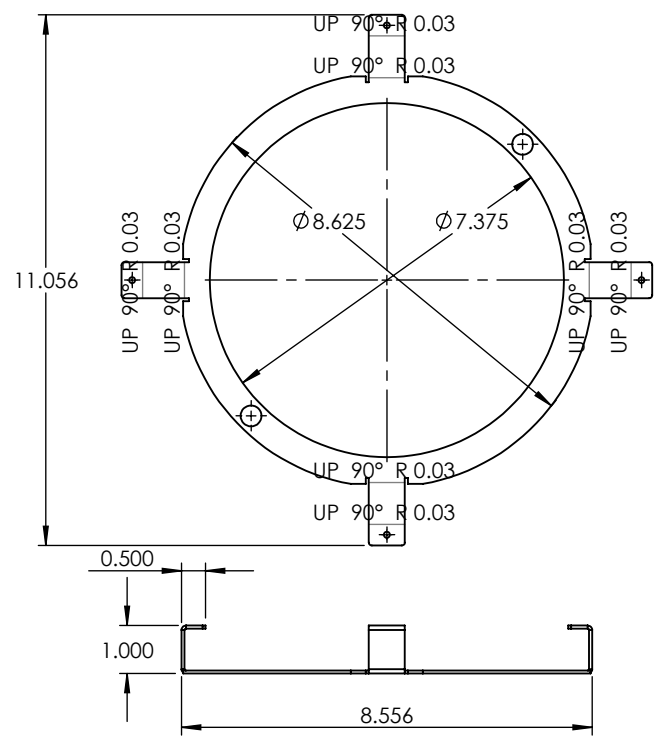
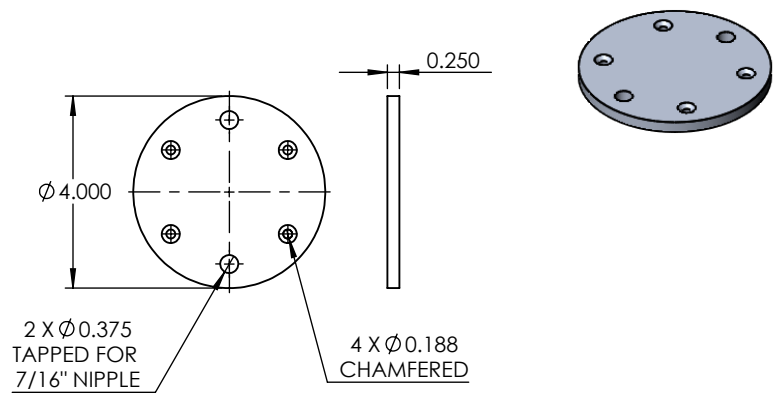
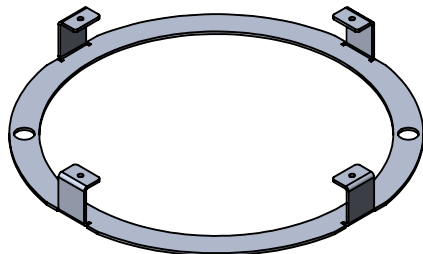

UNLESS OTHERWISE SPECIFIED:		NAME	DATE	TITLE: <b>GP-BOL-60"-DB-20W-MBK-CFA-40K</b>
DIMENSIONS ARE IN INCHES		DRAWN		
TOLERANCES:		CHECKED		
FRACTIONAL ±		ENG APPR.		
ANGULAR: MACH ±		MFG APPR.		SIZE DWG. NO. REV
BEND ±		Q.A.		
TWO PLACE DECIMAL ±		COMMENTS:		SCALE: 1:4 WEIGHT: SHEET 9 OF 11
THREE PLACE DECIMAL ±				
INTERPRET GEOMETRIC TOLERANCING PER:				
MATERIAL				
FINISH				
NEXT ASSY	USED ON			
APPLICATION		DO NOT SCALE DRAWING		

**PROPRIETARY AND CONFIDENTIAL**  
 THE INFORMATION CONTAINED IN THIS DRAWING IS THE SOLE PROPERTY OF <INSERT COMPANY NAME HERE>. ANY REPRODUCTION IN PART OR AS A WHOLE WITHOUT THE WRITTEN PERMISSION OF <INSERT COMPANY NAME HERE> IS PROHIBITED.

ITEM NO.	PART NUMBER	DESCRIPTION	QTY.
1	GP-BOL-60"-DB-20W-MBK-CFA-40K-SPUN CONE HEAD	SPUN ALUMINUM 0.125"	1

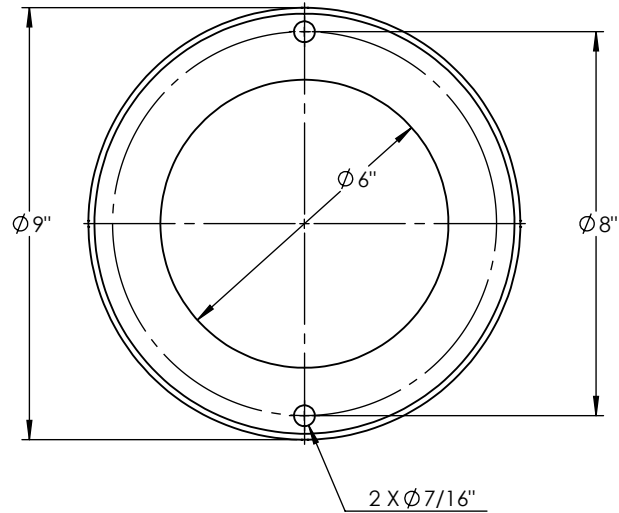
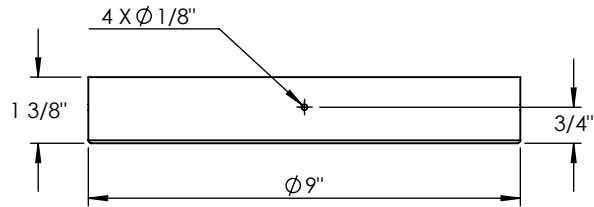
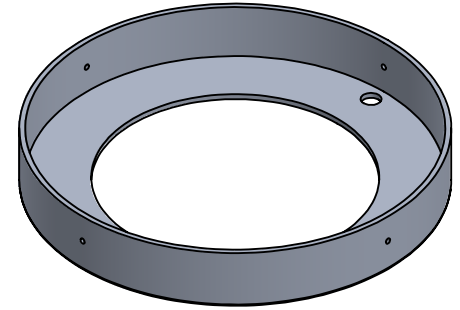

**PROPRIETARY AND CONFIDENTIAL**  
 THE INFORMATION CONTAINED IN THIS DRAWING IS THE SOLE PROPERTY OF <INSERT COMPANY NAME HERE>. ANY REPRODUCTION IN PART OR AS A WHOLE WITHOUT THE WRITTEN PERMISSION OF <INSERT COMPANY NAME HERE> IS PROHIBITED.

		UNLESS OTHERWISE SPECIFIED:		NAME	DATE	SPUN ALUMINUM 0.125"	
		DIMENSIONS ARE IN INCHES		DRAWN		TITLE:	
		TOLERANCES:		CHECKED		GP-BOL-60"-DB-20W-MBK-CFA-40K	
		FRACTIONAL ±		ENG APPR.		SIZE DWG. NO. REV	
		ANGULAR: MACH ± BEND ±		MFG APPR.		SCALE: 1:4 WEIGHT: SHEET 10 OF 11	
		TWO PLACE DECIMAL ±		Q.A.			
		THREE PLACE DECIMAL ±		COMMENTS:			
		INTERPRET GEOMETRIC TOLERANCING PER:					
		MATERIAL					
	NEXT ASSY	USED ON					
		FINISH					
	APPLICATION	DO NOT SCALE DRAWING					

ITEM NO.	PART NUMBER	DESCRIPTION	QTY.
1	GP-BOL-60"-DB-20W-MBK-CFA-40K-SPUN TOP CAP	SPUN ALUMINUM 0.080"	1

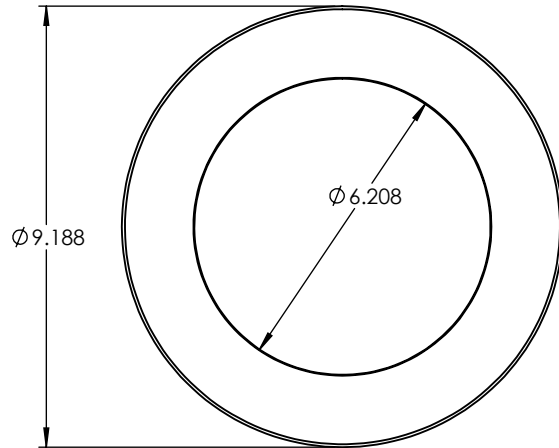
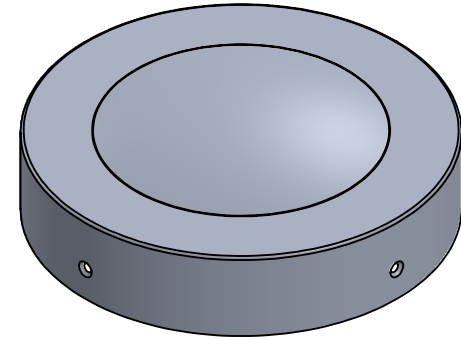
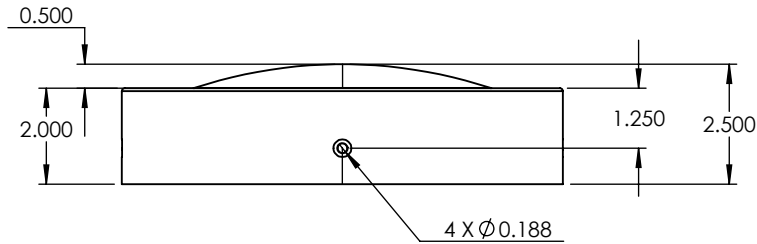

<p><b>PROPRIETARY AND CONFIDENTIAL</b> THE INFORMATION CONTAINED IN THIS DRAWING IS THE SOLE PROPERTY OF &lt;INSERT COMPANY NAME HERE&gt;. ANY REPRODUCTION IN PART OR AS A WHOLE WITHOUT THE WRITTEN PERMISSION OF &lt;INSERT COMPANY NAME HERE&gt; IS PROHIBITED.</p>			UNLESS OTHERWISE SPECIFIED:		NAME	DATE	SPUN ALUMINUM 0.080"	
			DIMENSIONS ARE IN INCHES TOLERANCES: FRACTIONAL ± ANGULAR: MACH ± BEND ± TWO PLACE DECIMAL ± THREE PLACE DECIMAL ±	DRAWN			TITLE:	
			INTERPRET GEOMETRIC TOLERANCING PER:	CHECKED			GP-BOL-60"-DB-20W-MBK-CFA-40K	
			MATERIAL	ENG APPR.			SIZE DWG. NO. REV	
			FINISH	MFG APPR.			SCALE: 1:4 WEIGHT: SHEET 11 OF 11	
	NEXT ASSY	USED ON	COMMENTS:					
	APPLICATION		DO NOT SCALE DRAWING					