

#9A BC "	D5FHBI A 69F	89G7 F DHC B	E HM 7 I H
%	J 5!K !%&!%&K !7 <!K :!H6@') ?!657 ?D@5H9	&& : 51 : 9	%
&	J 5!K !%&!%&K !7 <!K :!H6@') ?! : F9D@5H9	&& : 51 : 9	%
'	J 5!K !%&!%&K !7 <!K :!H6@') ?!6CL : F5A 9	&& : 51 : 9	%
(J 5!K !%&!%&K !7 <!K :!H6@') ?! : F5A 9!H6	&& : 51 : 9	(
)	J 5!K !%&!%&K !7 <!K :!H6@') ?!57 FM@7	57 FM@7	%
+	9gdYbH97 <S%&\$&+J SG?l , \$, \$+*	8F J 9F	%
,	5 'HJ @98 SDB %\$%\$SFYj 8	@98	&

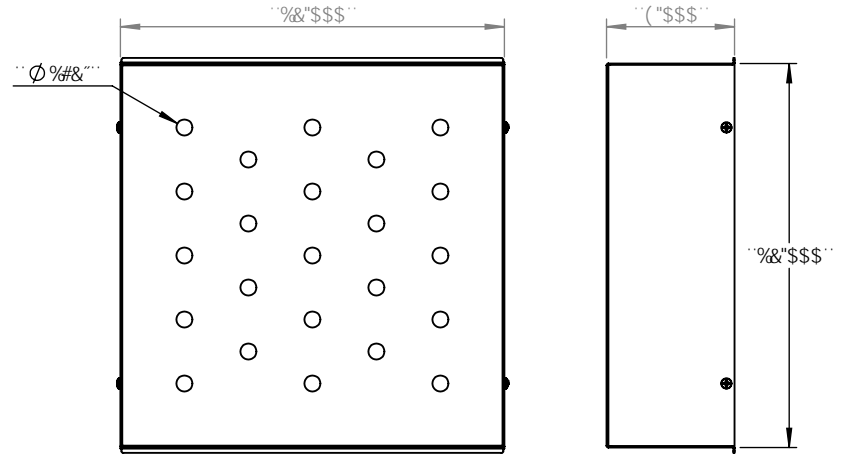
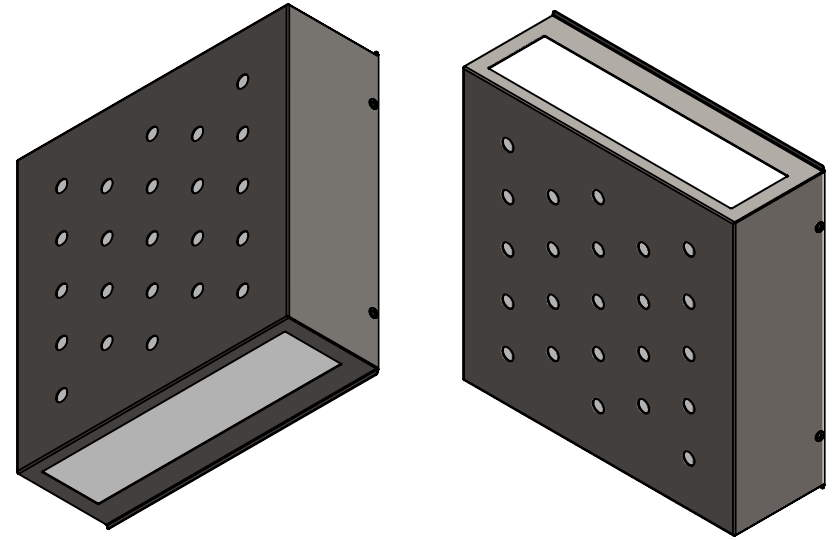
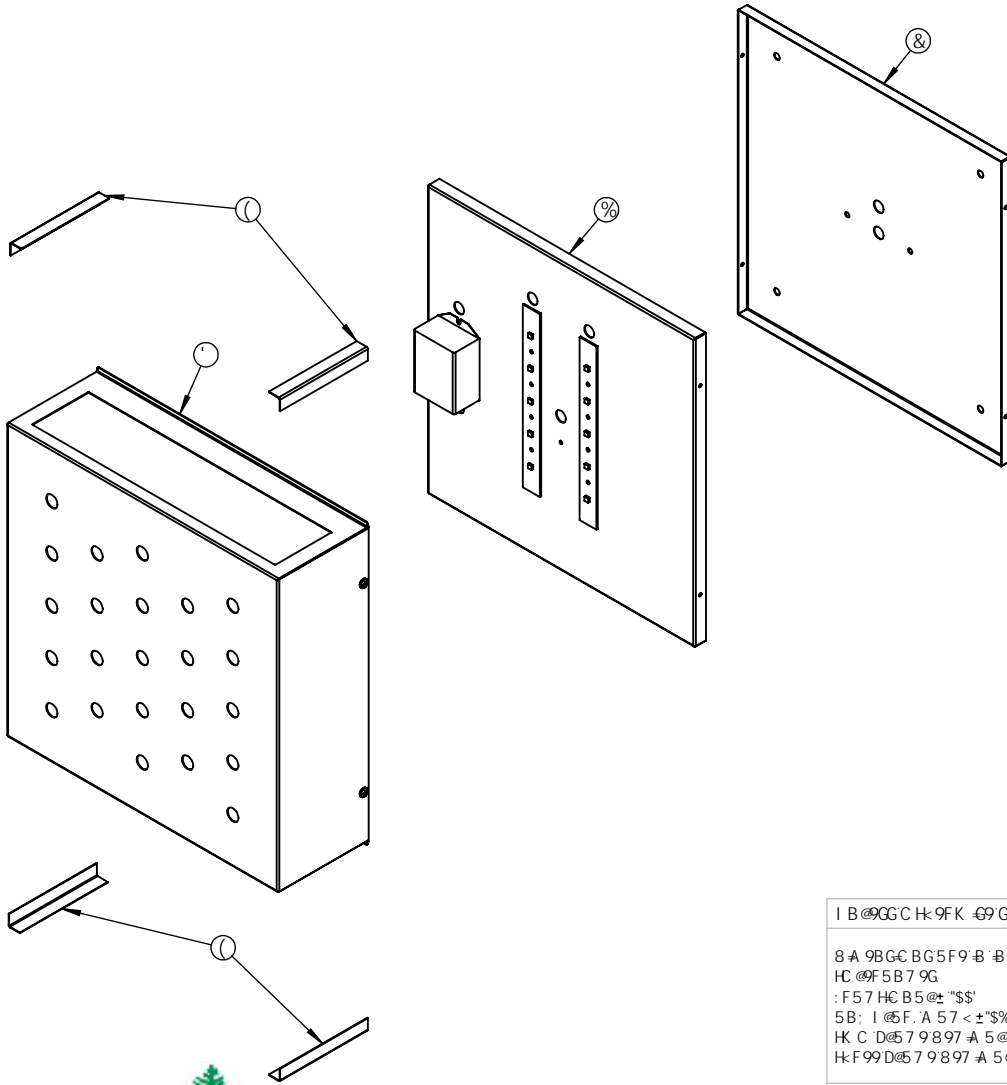

EVERGREEN LIGHTING

I B @9GC H: 9FK 69 GD97 ÷ 98.	B5A 9	85H9	
8 A 9BGC BG5F9 B B7 <9G HC @F5B7 9G : F57 HC B5 @± "\$\$" 5B; I @5F: A 57 <± "\$%""69B8 ± HK C D@57 9897 A 5 @± "\$\$" H: F99D@57 9897 A 5 @± "\$\$"	8F5K B		H#@.
BH@DF9H: 9CA 9FF 7 HC @F5B7 B: D9F. A 5HF 5@	7 <97 ?98	9B; 5DDF"	J 5!K !%&!%&K !7 <!K :!H6@') ?
: B @	A: : 5DDF"	E "5"	
5 @69B8 F58 ± G" \$' \$"	7 C A A 9BHG		G#9 8K ; ""BC "
5DD@7 5HC B			5 H7 ?9H&' &, +
8C BCHG75 @98F5K B:			F9J
			G7 5 @. %* K 9 ÷ <H'
			G<99H%C :)

)

(

&

%

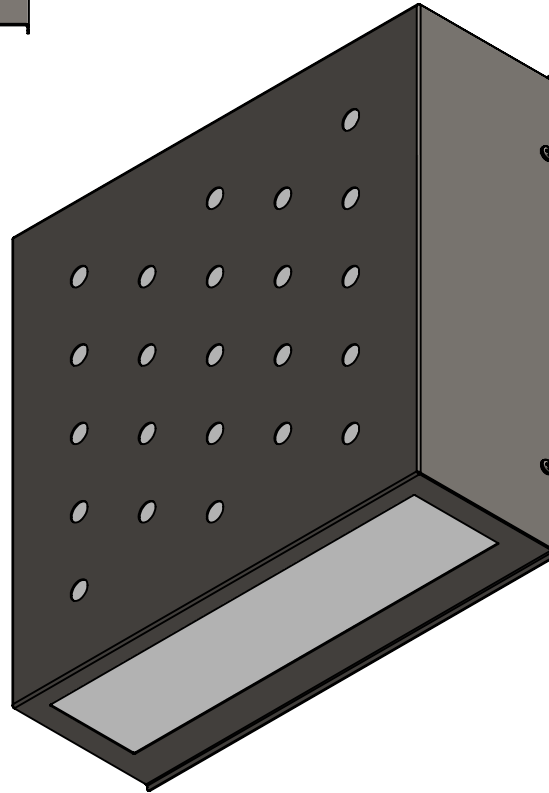
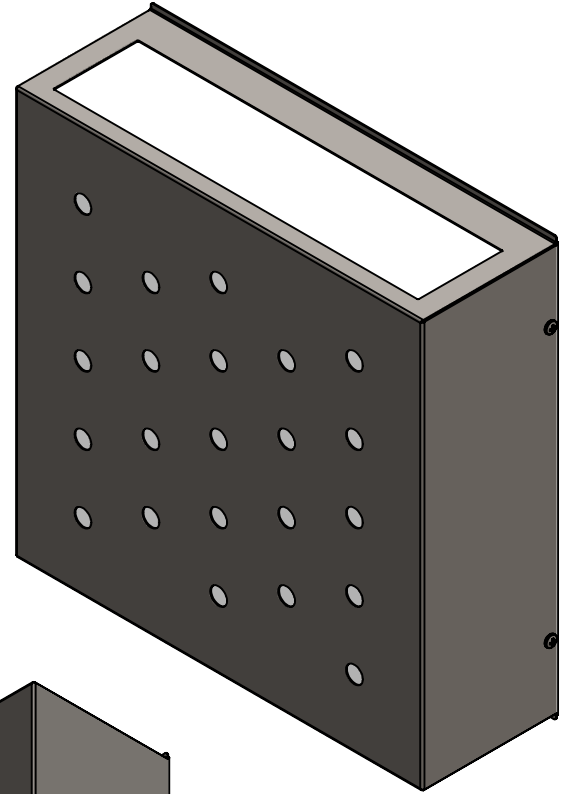
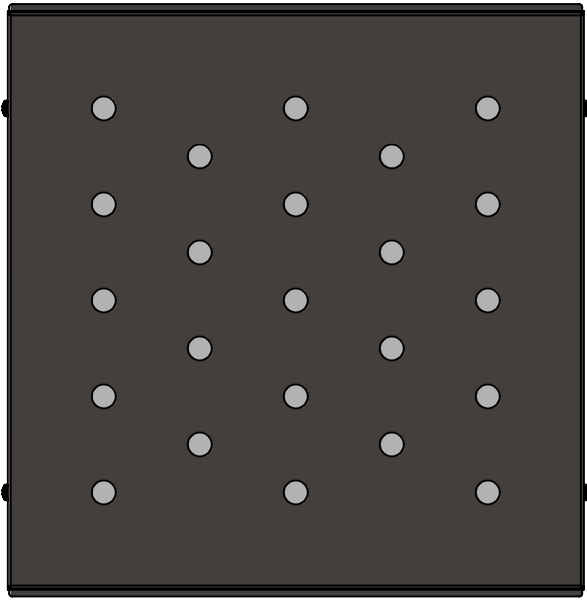

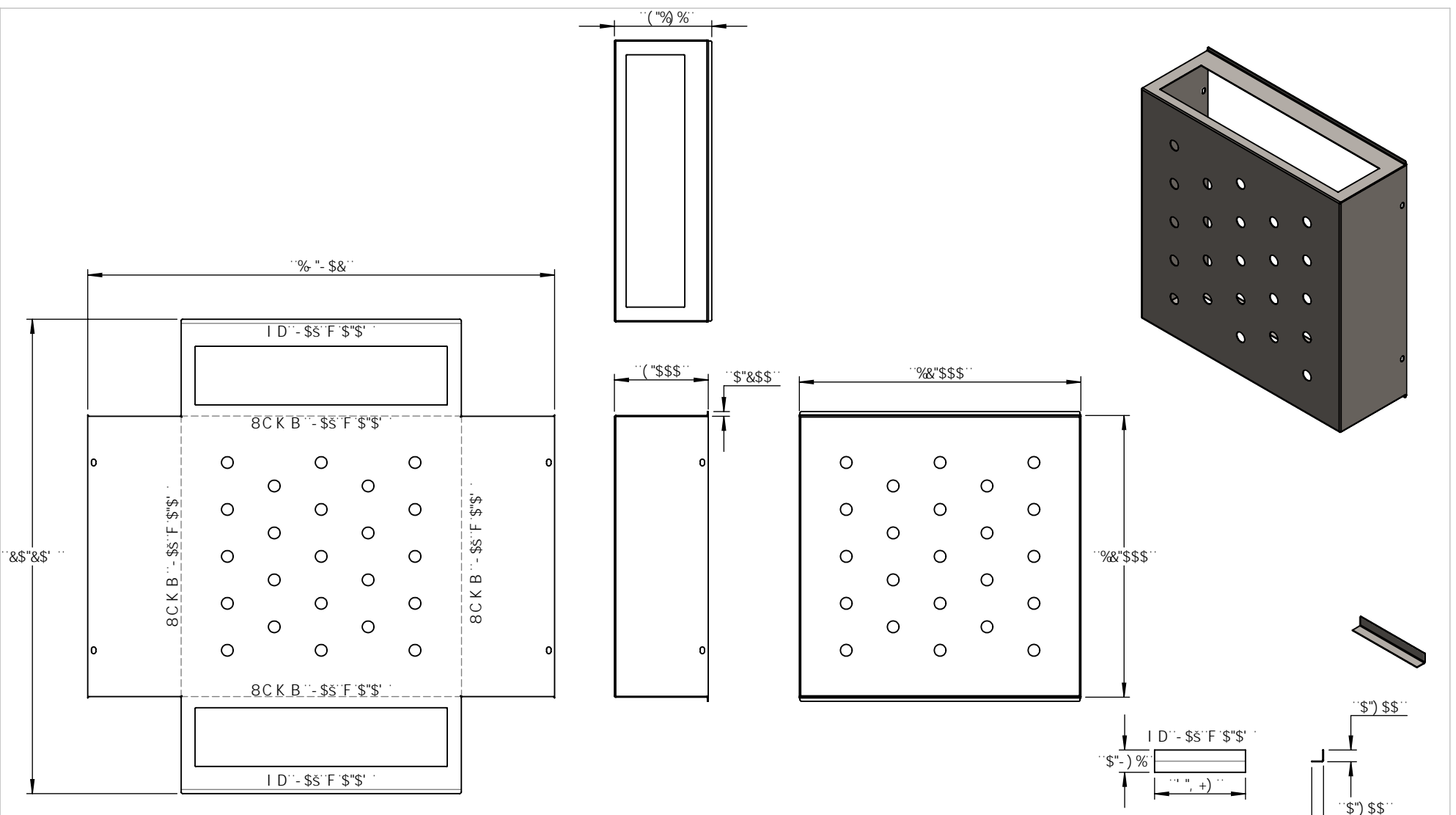

DFC DF 9 5 FM 5 B 8 7 C B : 8 9 B H 5 @
 H < 9 B : C F A 5 H C B 7 C B H 5 B 9 8 B H < 6
 8 F 5 K B : 6 H < 9 G C @ D F C D 9 F H M C :
 O B G 9 F H 7 C A D 5 B M B 5 A 9 < 9 F 9 2 " 5 B M
 F 9 D F C 8 1 7 H C B B D 5 F H C F 5 G 5 K < C @
 K H < C 1 H H < 9 K F H 9 B D 9 F A 6 G C B C :
 O B G 9 F H 7 C A D 5 B M B 5 A 9 < 9 F 9 2 6
 D F C < 6 H 9 8 *

		I B @ G G C H : 9 F K 6 9 G D 9 7 ÷ 9 8 .		B 5 A 9	8 5 H 9
		8 A 9 B G C B G 5 F 9 B B 7 < 9 G H C @ F 5 B 7 9 G : F 5 7 H C B 5 @ ± 5 B : I @ 5 F : A 5 7 < ± 6 9 B 8 ± H K C D @ 5 7 9 8 9 7 A 5 @ ± ± H F 9 9 D @ 5 7 9 8 9 7 A 5 @ ±	8 F 5 K B 7 < 9 7 ? 9 8 9 B : 5 D D F * A : : 5 D D F *		
		B H F D F 9 H : 9 C A 9 F 7 H C @ F 5 B 7 B : D 9 F . A 5 H F 5 @	E " 5 " 7 C A A 9 B H G		
B 9 L H 5 G G M	I G 9 8 C B	: B 6 <			
	5 D D @ 7 5 H C B	8 C B C H G 7 5 @ 8 F 5 K B :			

J 5 ! K ! % & ! % & K ! 7 < ! K : ! H @ ') ?
 G A 9 8 K ; " " B C " F 9 J
 5
 G 7 5 @ . % * K 9 ÷ < H ' G < 9 9 H ' C :)

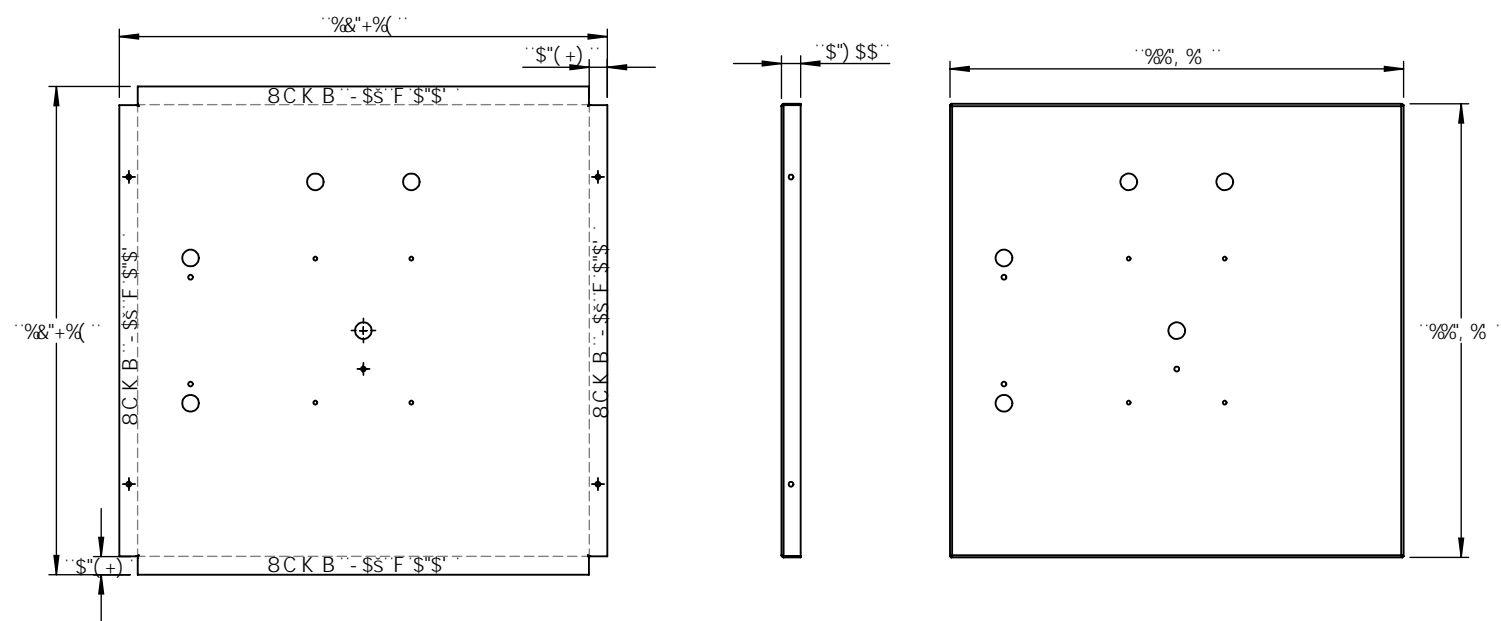
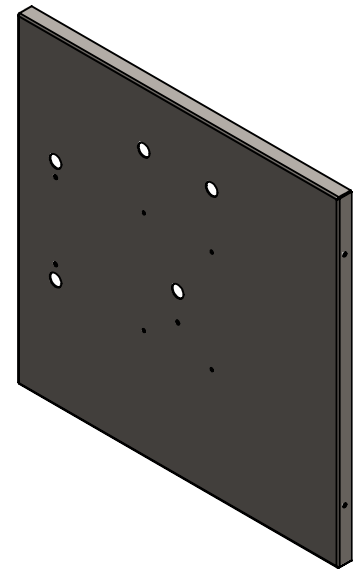

DFC DF 9 5 FM 5 B 8 7 CB : 8 9 B H 5 @
 H: 9 B: CFA 5HC B 7 C B H 5 B 9 8 B H: 6
 8F5K B: 6H: 9GC @DFC D9F HVC:
 O B G 9 F H 7 C A D 5 B M B 5 A 9 < 9 F 9 2 " 5 B M
 F 9 D F C 8 1 7 H C B B D 5 F H C F 5 G 5 K < C @
 K H: C 1 H H: 9 K F H 9 B D 9 F A 6 G C B C:
 O B G 9 F H 7 C A D 5 B M B 5 A 9 < 9 F 9 2 G
 D F C < 6 # 9 8 "

		I B @GG C H: 9FK 69 GD97 ÷ 98.		B5A 9	85H9	&& ; 51 ; 9		
		8 A 9 B G C B G 5 F 9 B B 7 < 9G HC @F 5 B 7 9G ; F 5 7 H C B 5 @ ± 5 B ; I @ F : A 5 7 < ± 6 9 B 8 ± H K C D @ 5 7 9 8 9 7 A 5 @ ± H: F 9 9 D @ 5 7 9 8 9 7 A 5 @ ±	8F5K B 7 < 97 ? 98 9B: 5 DDF" A: ; 5 DDF"					H # @.
		B H 9 F D F 9 H: 9 C A 9 F 7 HC @F 5 B 7 B: D 9 F. A 5 H 9 F 5 @	E " 5" 7 C A A 9 B H G			J 5 ! K ! % & ! % & K ! 7 < ! K : ! H @ ') ?		
	B 9 L H 5 G G M	I G 9 8 C B	: B 6 <			G A 9 5	8 K ; " " B C "	F 9 J
	5 D D @ 7 5 H C B	8 C B C H G 7 5 @ 8 F 5 K B:				G 7 5 @ . %)	K 9 ÷ < H '	G < 9 9 H (' C :)

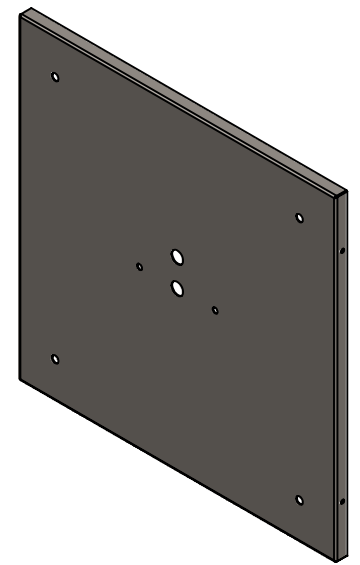
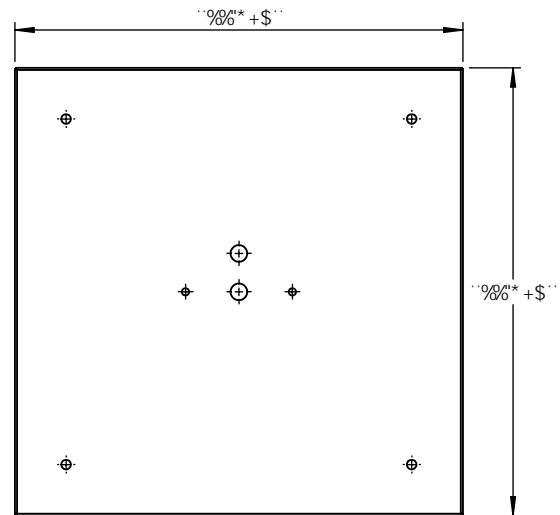
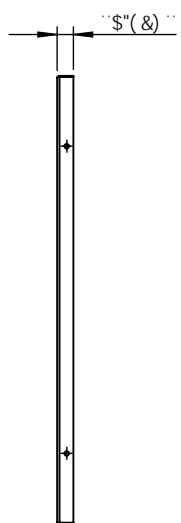
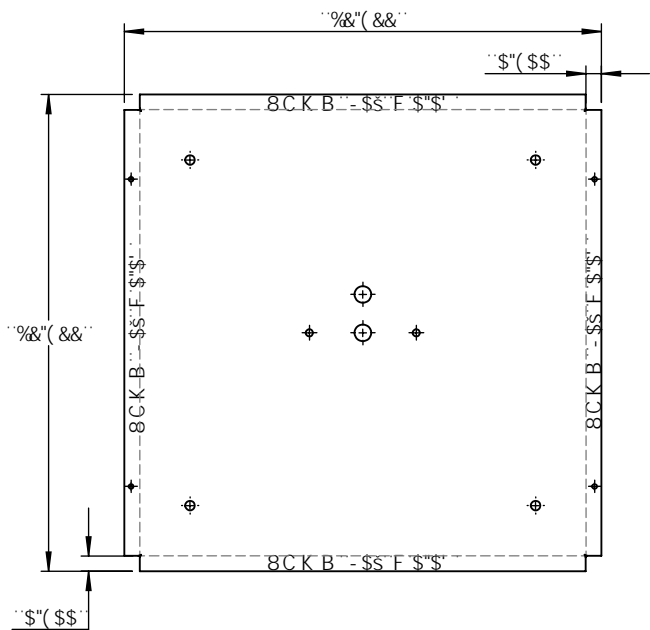

DFC DF 5FM5B87CB: 89BH5@
 H:9 B: CFA 5HC B 7C B15 B98 B H:6
 8F5K B: 6H:9GC @DFC D9FHC:
 OBG9FH7CA D5BMB5A 9<9F92" 5BM
 F9DFC 817HC B B D5FHCF 5G5 K <C @
 K H:C1 H:9K F H9B D9FA 6GC B C:
 OBG9FH7CA D5BMB5A 9<9F92 G
 DFC <6#98"

		I B @GGC H:9FK 69GD97 ÷ 98.		B5A 9	85H9	&&; 51; 9
		8A 9BG C BG5F9 B B7 <9G HC @F5B7 9G ;F57 HC B5 @± 5B; I @5F: A 57 <±69B 8 ± HK C D@57 9897 A 5@± H:F99D@57 9897 A 5@±	8F5K B 7 <97 ?98 9B; 5DDF" A:; 5DDF"			
		BH9DF9H: 9CA 9F7 HC @F5B7 B: D9F. A 5H9F 5@	E "5" 7CA A 9BHG			J 5!K !%&!%&K !7 <!K :!H@')?
	B9LH5GGM	I G98 CB	: B 6<			G#9 8K; ""BC" F9J
	5DD@7 5HC B	8C BCHG75 @98F5K B:				G7 5 @.%) K 9 ÷ <H' G<99H) 'C:)