

#9A BC "	D5FHBI A 69F	8 9G7 F-DHC B	E HM 7 I H
%	95, %\$A 6?!9%&) K !&+?!7 5GH7 5BC DM	7 5GH5@ A -BI A	%
&	95, %\$A 6?!9%&) K !&+?!GDI B 7 I D	GDI B 5@ A -BI A "\$"\$ "\$"	%
'	95, %\$A 6?!9%&) K !&+?!GDI B 6C K @	GDI B 5@ A -BI A "\$"\$ "\$"	%
(	95, %\$A 6?!9%&) K !&+?!GDI B 8C C F	GDI B 5@ A -BI A "\$"\$ "\$"	%
)	95, %\$A 6?!9%&) K !&+?!GDI B 8C C F 6F57 ?9H	GDI B 5@ A -BI A "\$"\$ "\$"	%
*	95, %\$A 6?!9%&) K !&+?!@98 6F57 ?9H	5@ A -BI A "\$"\$ "\$"	%
+	95, %\$A 6?!9%&) K !&+?!A C I BHB: 6F57 ?9H	5@ A -BI A "\$"\$ "\$"	%
,	95, %\$A 6?!9%&) K !&+?!8F 9F 6F57 ?9H	5@ A -BI A "\$"\$ "\$"	%
-	95, %\$A 6?!9%&) K !&+?!9%5FA H 69	+# " 5@ A -BI A H 69	%
%\$	95, %\$A 6?!9%&) K !&+?!57 FM@7 @9BG	57 FM@7	%
%&	BI H	BI H	%
%&	7 C C @5 B 7 9 7 D@ \$) !\$%\$% < 95 HGB ?	< 95 HGB ?	%
%	57 &) 7 8 +\$5 H@ @98 8F 9F	8F 9F	%
%/	5 HJ @98 SD7 B S8 &\$ \$!&\$K	@98	%

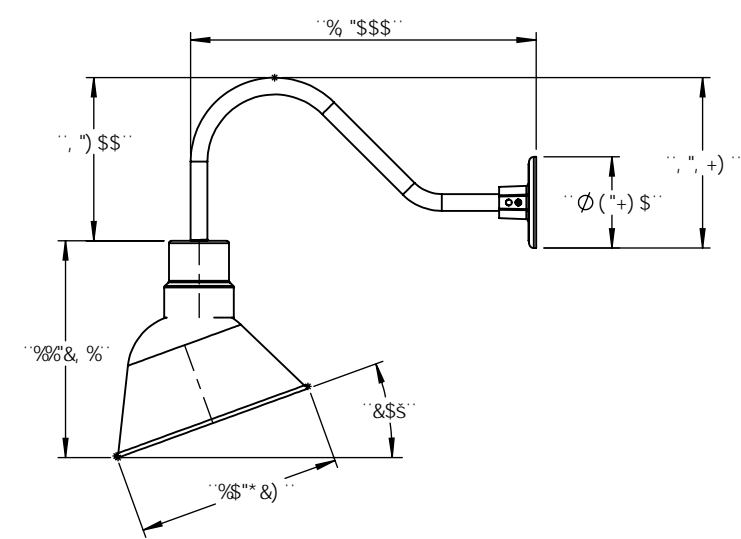
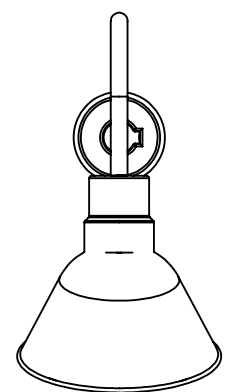
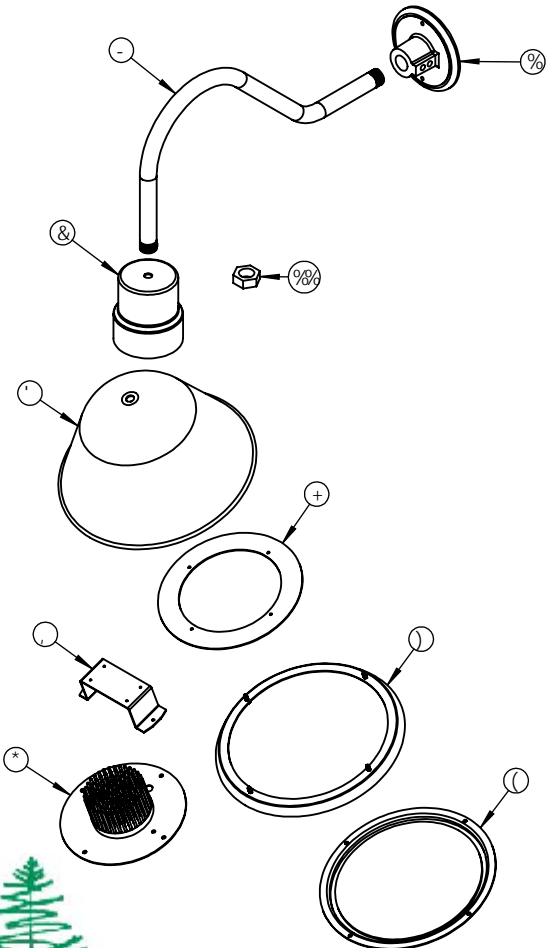

**EVERGREEN LIGHTING**

I B @GGC H: 9FK 69 GD97 ÷ 98.	B5A 9	85H9	H# @.	
8-A 9BG@ BG5F9 B -B7 < 9G HC @F5B7 9G : F57 HC B5 @± "\$\$" 5B: I @F: A 57 < ± "\$\$ " 69B 8 ± HK C D@5 7 9 8 97 A 5 @ ± "\$\$ % H: F99 D@5 7 9 8 97 A 5 @ ± "\$\$ %	8F5K B			95, %\$A 6?!9%&) K !&+?
B H@FDF 9H: 9C A 9F 7 HC @F5B7 B: D9F. A 5 H@F 5 @	9B: 5DDF"	A: 5DDF"		
: B @-	E "5"	7 C A A 9BHG		G# 9 8K ; " " BC "
5 @@69B8 F58 4 G" \$' \$"			<b>5</b> H7 ? 9H & ' ' &)	
5DD@7 5HC B	8C B CHG7 5 @9 8F5K B:		G7 5 @. % % \$ K 9 ÷ < H'	
			G < 99H % C : ' +	

) ( ' & %

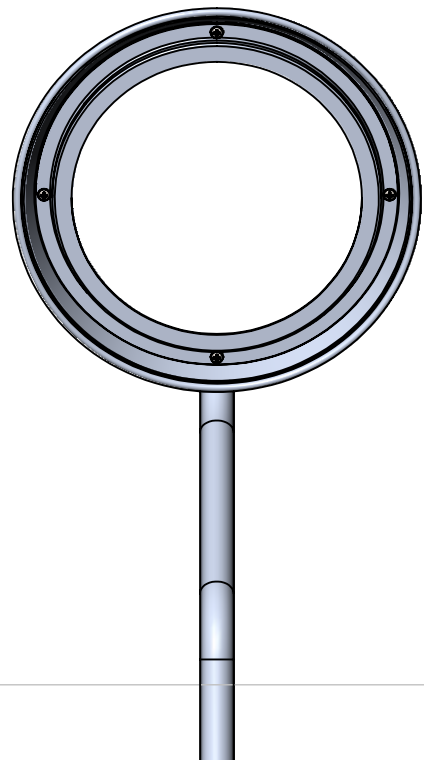
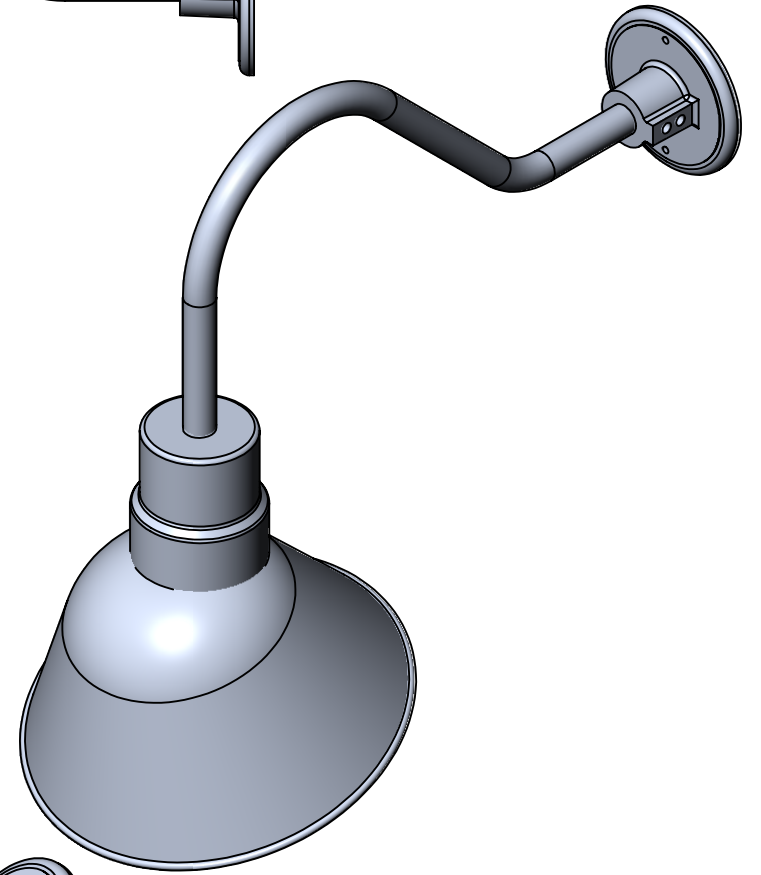
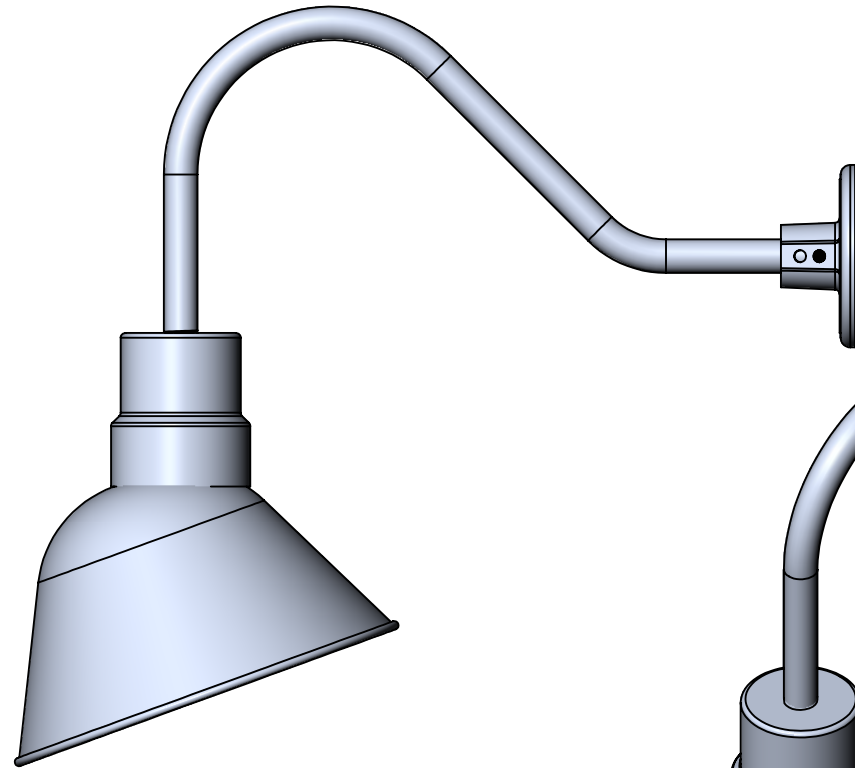
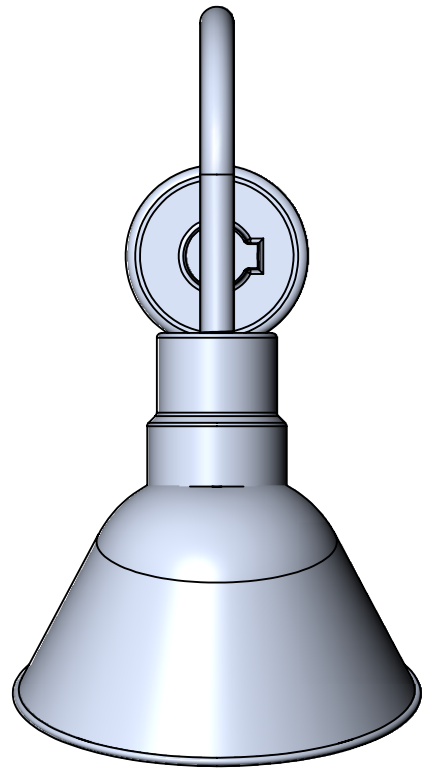

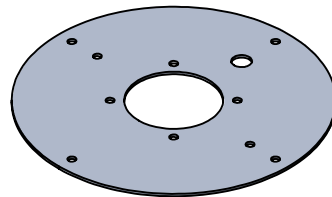
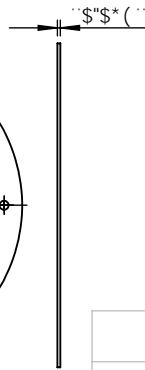
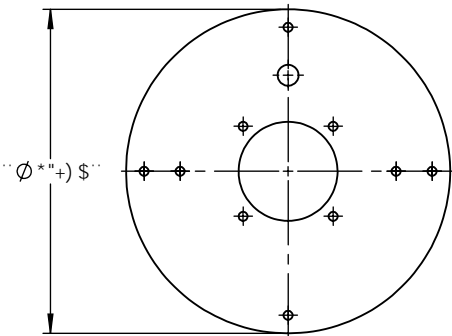
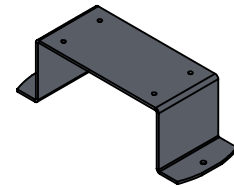
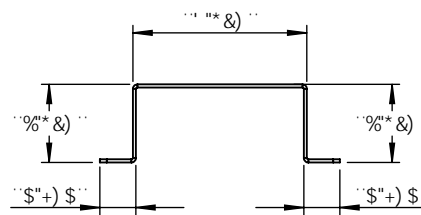
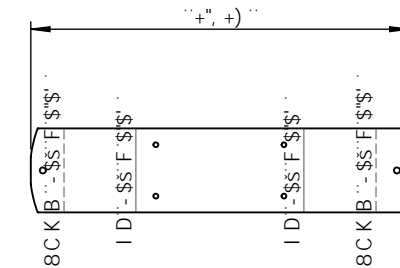
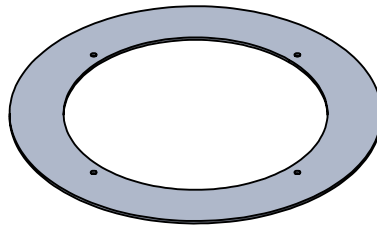
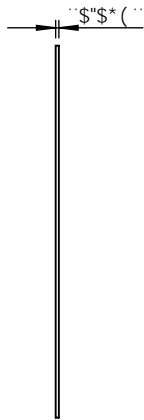
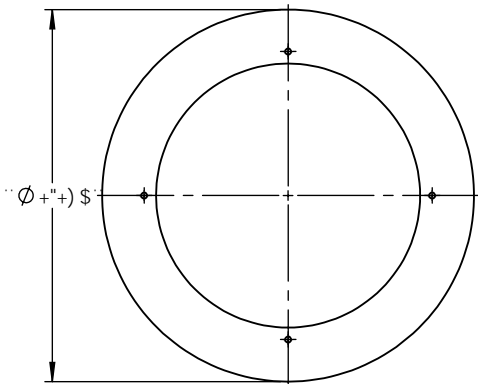

DFC DF-5FM5B87CB: 89BH5@  
 H:9 B: CFA 5HC B 7 C B H5 B 98 B H:6  
 8F5K B: 6H:9 GC @DFC D9FHVC:  
 OBG9FH7 CA D5BMB5A 9<9F92" 5BM  
 F9DFC 81 7 HC B B D5FHCF 5G5 K <C @  
 K H:C I H:9K F H9B D9FA 6GC B C:  
 OBG9FH7 CA D5BMB5A 9<9F92 6  
 DFC <6H98\*

		I B @GGCH:9FK 69GD97 ÷ 98.		B5A 9	85H9	5 @ A BIA '\$\$*' ) "	
		8 A 9BGC BG5F9 B B7 <9G HC @F5B7 9G : F57 HC B5 @± 5B: I @F: A 57 <± .....69B8 ± HK C D@57 9897 A 5 @± H:F99D@57 9897 A 5 @±	8F5K B 7 <97 ?98 9B: 5DDF" A: : 5DDF"			H#@.	
		B H9FDF9H: 9C A 9FF 7 HC @F5B7 B: D9F.	E "5"			95, %\$A 6?!9%&) K !&+?	
		A 5H9F 5@	7 C A A 9BHG			G#9 <b>5</b>	8K ; "'BC" F9J
B9LH5GGM	I G98 C B	: B<				G7 5 @.% (	K 9 ÷ <H' G<99H' 'C : '+
	5DD@7 5HC B	8C B CHG7 5 @98F5K B:					

)

(

&

%

HC H5@H 69@B; <HG&\*"" B7@ 8B; HKF95898@B; HKG

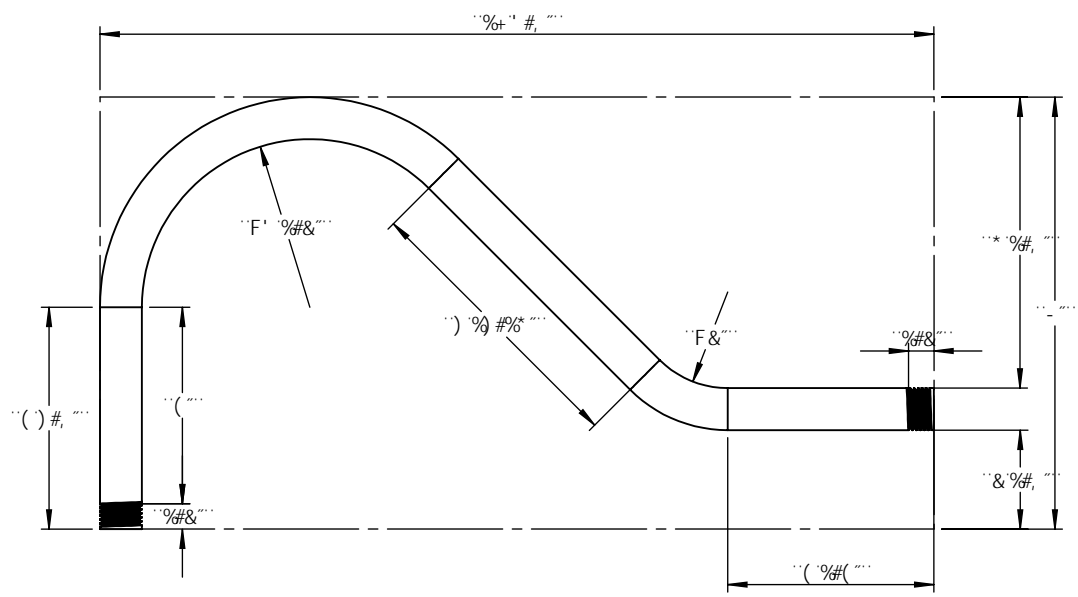
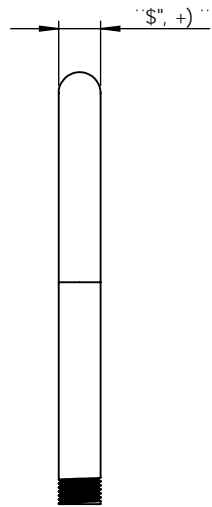
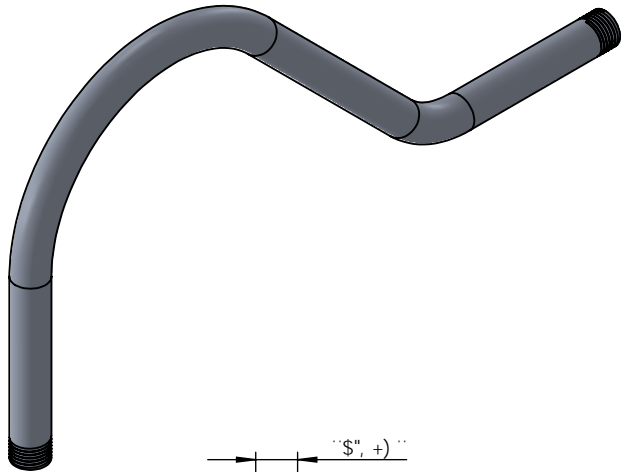

DFC DF-5FM5B87CB: 89BH5@  
 HK9B: CFA 5HC B7C B15B98 B HK-6  
 8F5K B: 6HK-9GC @DFC D9F HVC:  
 OB G9FH7CA D5BMB5A 9<9F92" 5BM  
 F9DFC 817HC B-B D5FHCF 5G5K <C @  
 K HKC1 HK9K F H9B D9FA 6GC B C:  
 OB G9FH7CA D5BMB5A 9<9F92 6  
 DFC <6#98"

		I B @GGCH: 9FK 69GD97 ÷ 98.	B5A 9	85H9
		8A 9BGC BG5F9 B B7 <9G HC @F5B7 9G : F57 HC B5 @± 5B: I @5F: A 57 <± ..... 69B8 ± HK C D @579897 A 5 @± HKF99D @579897 A 5 @±	8F5K B	
		B H9DFD9H: 9CA 9FF 7 HC @F5B7 B: D9F.	7 <97 ?98	
		A 5H9F 5@	9B: 5DDF"	
		: B 6<	A: : 5DDF"	
		8C B CHG75 @98F5K B:	E "5"	
			7 C A A 9BHG	
B9LH5GGM	I G98 C B			
5DD@7 5HC B				

+#, ""5@ A B1A H 69  
 H#@.  
 95, %\$A 6?!9%&) K !&+?  
 GA9 8K; ""BC" F9J  
**5**  
 G75 @.% ( K 9÷ <H' G<99H( 'C: '+

) ( ' & %

#DA 'BC "	D5FHBI A 69F	8 9G7 F-DHC B	E HM
%	95, %\$A 6?!9%&) K !&+?!GDI B '6C K @	GDI B '5@ A -BI A '\$"\$, "\$'	%

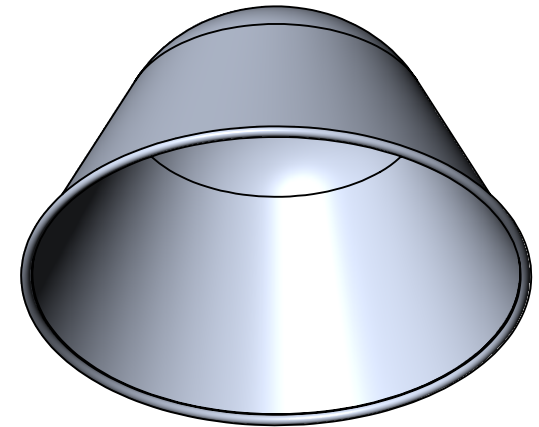
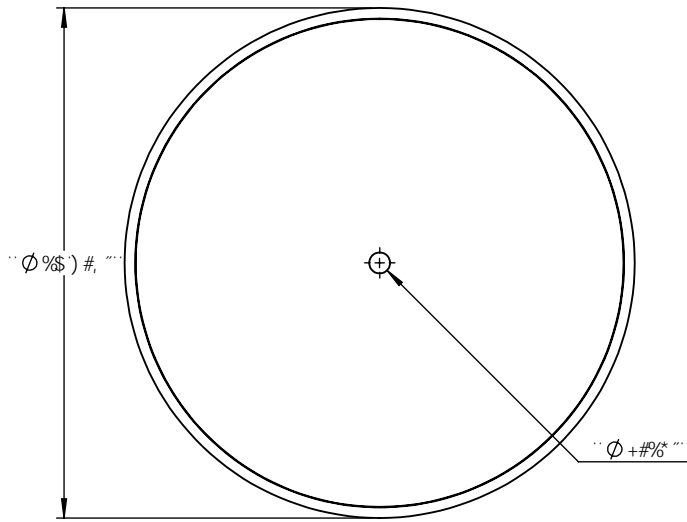
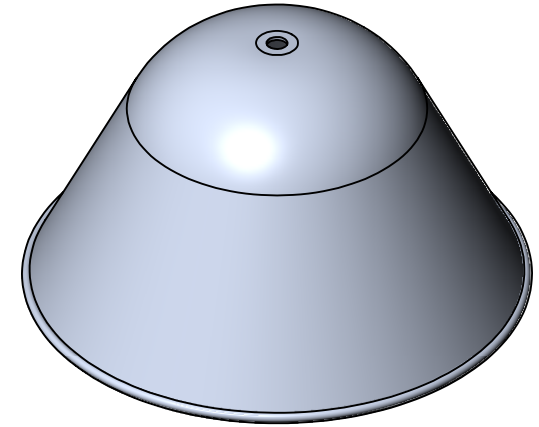
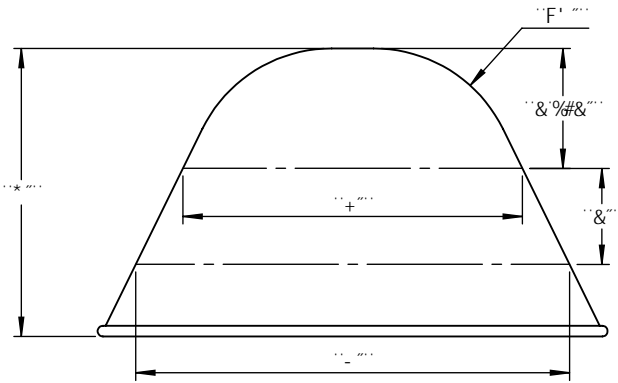

<b>DFC DF-9-5FM5B87CB: 89BH5@</b> H:9 B: CFA 5HC B 7 C B H5-B 98-B H:6 8F5K B: 6H:9GC @DFC D9FHMC: OBG9FH7 CA D5BMB5A 9<9F92" 5BM F9DFC 81 7 HC B -B D5FHCF 5G5 K <C @ K H:C I H:9K F H9B D9FA 6GC B C: OBG9FH7 CA D5BMB5A 9<9F92 6 DFC <6+98"			I B @GGC H:9FK 69GD97 ÷ 98.  8-A 9BG@BG5F9-B 'B7 <9G HC @F5B7 9G :F57 HC B5@± 5B: I @F: A 57 <±.....69B8 ± H C D@57 9897 A 5@± H:F99D@57 9897 A 5@±		B5A 9	85H9	<b>GDI B '5@ A -BI A '\$"\$, "\$'</b>  <b>H#@.</b>  95, %\$A 6?!9%&) K !&+?
			-BH9DF9H: 9CA 9FF 7 HC @F5B7 B: D9F.  A 5H9F 5@	8F5K B  7 <97 ?98  9B: 5DDF"  A: : 5DDF"  E "5"  7 C A A 9BHG			
	B9LH5GGM	I G98 C B	:B 6<				
		5DD@7 5HC B	8C B CHG7 5@98F5K B:				

)

(

&

%

#9A BC "	D5FHBI A 69F	89G7 F-DHC B	E HM
%	95, %\$A 6?!9%&) K !&+?!GDI B 7 I D	GDI B 5@ A -BI A "\$\$, \$"	%

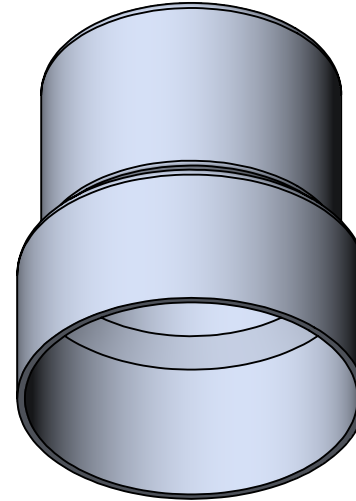
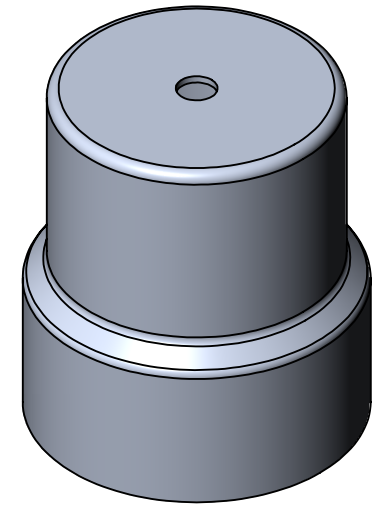
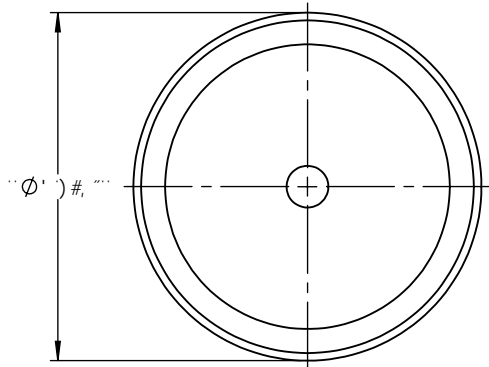
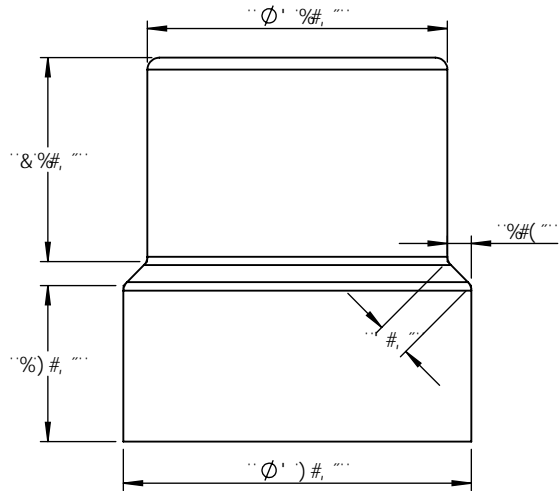

**DFC DF-9-5FM5B87CB: 89BH5@**  
 H-9 B: CFA 5HC B 7 C B H 5 B 98 -B H-6  
 8F5K B: 4G H-9 GC @DFC D9FHMC:  
 OBG9FH7 CA D5BMB5A 9<9F92" 5BM  
 F9DFC 81 7 HC B -B D5FHCF 5G5 K <C @  
 K H-C I H H-9 K F H H B D9FA 6GC B C:  
 OBG9FH7 CA D5BMB5A 9<9F92-6  
 DFC <6H98"

		I B @GGC H: 9FK 69 GD97 ÷ 98.	B5A 9	85H9	GDI B 5@ A -BI A "\$\$, \$"
		8-A 9BGC BG5F9-B -B7 <9G HC @F5B7 9G ; F57 HC B5@± 5B: I @5F: A 57 <± .....69B8 ± HK C D@57 9897 A 5@±± H: F99D@57 9897 A 5@±	8F5K B		
		B H9FDF 9H: 9C A 9F 7 HC @F5B7 B: D9F.	7 <97 ?98		95, %\$A 6?!9%&) K !&+?
		A 5H9F 5@	9B: 5DDF"		
		: B 6<	A: : 5DDF"		G#9 <b>5</b>
	B9LH5GGM	I G98 C B	E "5"		
	5DD@7 5HC B	8C B CHG7 5@98F5K B:	7 C A A 9BHG		F9J
					G7 5 @. %& K 9 ÷ <H'
					G<99H* 'C: '+

)

(

&

%

#DA BC "	D5FHBI A 69F	89G7 F-DHC B	E HM
%	95, %\$A 6?!9%&) K !&+?IGDI B 8CCF 6F57?9H	GDI B 5@ A -BI A "\$\$, \$"	%

#DA BC "	D5FHBI A 69F	89G7 F-DHC B	E HM
%	95, %\$A 6?!9%&) K !&+?IGDI B 8CCF	GDI B 5@ A -BI A "\$\$, \$"	%

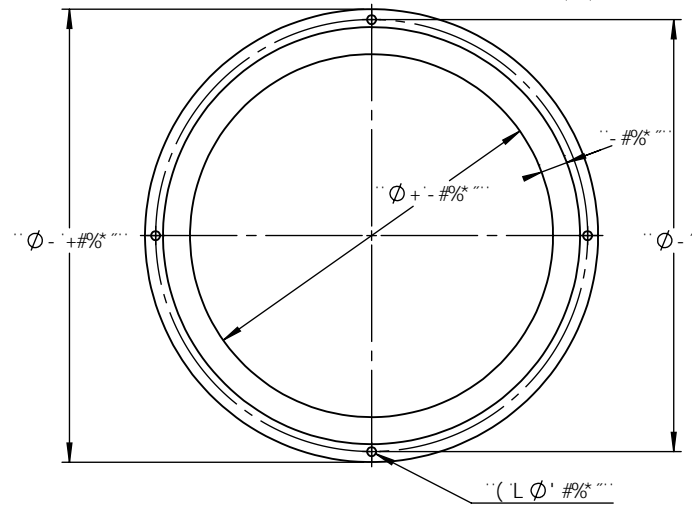
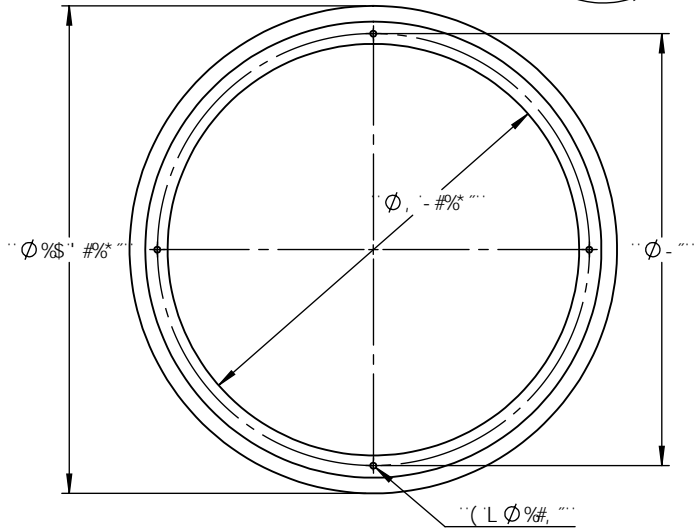
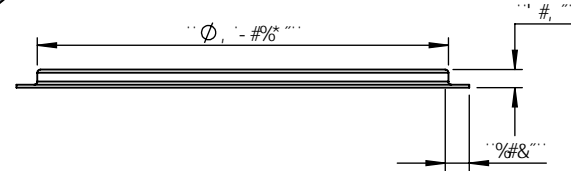
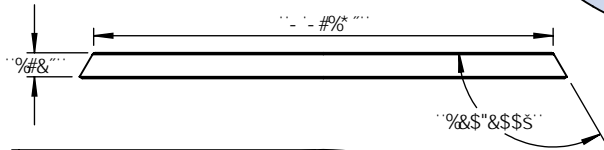
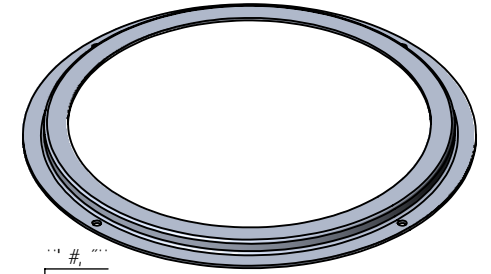
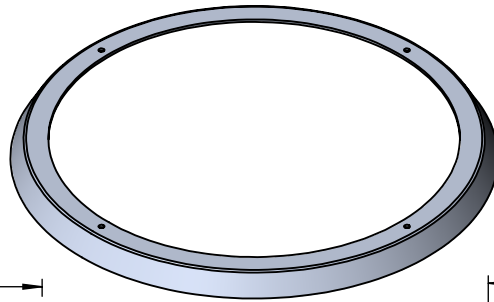

D5FHBI A 69F  
 H-9 B: CFA 5HC B 7 C BI 5-B 98 -B H-6  
 8F5K B: 6H-9 GC @DFC D9FHMC:  
 OBG9FH7 CA D5BMB5A 9<9F92" 5BM  
 F9DFC 81 7 HC B -B D5FHCF 5G5 K <C @  
 K H-C I H-9 K F H9B D9FA 6GC B C:  
 OBG9FH7 CA D5BMB5A 9<9F92 6  
 DFC <6#98"

		I B @GGCH: 9FK 69 GD97 ÷ 98.		B5A 9	85H9
		8-A 9BG C BG5F9-B -B7 <9G HC @F5B7 9G : F57 HC B5 @± 5B: I @5F: A 57 <± ..... 69B 8 ± H K C D @5 7 9 8 97 A 5 @ ± H: F99 D @5 7 9 8 97 A 5 @ ±	8F5K B		
		B H9DF 9H: 9C A 9FF 7 HC @F5B7 B: D9F.	7 <97 ?98		
		A 5H9F 5 @	9B: 5DDF"		
			A: : 5DDF"		
			E "5"		
			7 C A A 9BHG		
B9LH5GGM	I G98 C B	: B 6<			
5DD@7 5HC B		8C B CHG7 5 @98F5K B:			

GDI B 5@ A -BI A "\$\$, \$"		
H#@.		
95, %\$A 6?!9%&) K !&+?		
G#9	8K ; "BC"	F9J
5		
G7 5 @. % (	K 9 ÷ <H'	G<99H+C: '+

)

(

&

%