

#9A BC "	D5FHBI A 69F	8 9G7 F DHC B	E HM	7 I H
%	C L J B M % & K ! A B ! K : ! & ( m i ( % ? ! 6 5 7 ? D @ 5 H 9	& & ; 5 I ; 9	%	
&	C L J B M % & K ! A B ! K : ! & ( m i ( % ? ! H C D G 8 9	& & ; 5 I ; 9	&	
'	C L J B M % & K ! A B ! K : ! & ( m i ( % ? ! G 8 9	& & ; 5 I ; 9	&	
(	C L J B M % & K ! A B ! K : ! & ( m i ( % ? ! 5 7 F M @ 7	5 7 F M @ 7	%	
)	9 g d Y b H 9 7 < S % & \$ & + + J S G ? I , \$ , \$ + *	8 F @ 9 F	%	
*	5 H U @ 9 8 S D B % \$ % \$ S F Y J 8	@ 9 8	&	

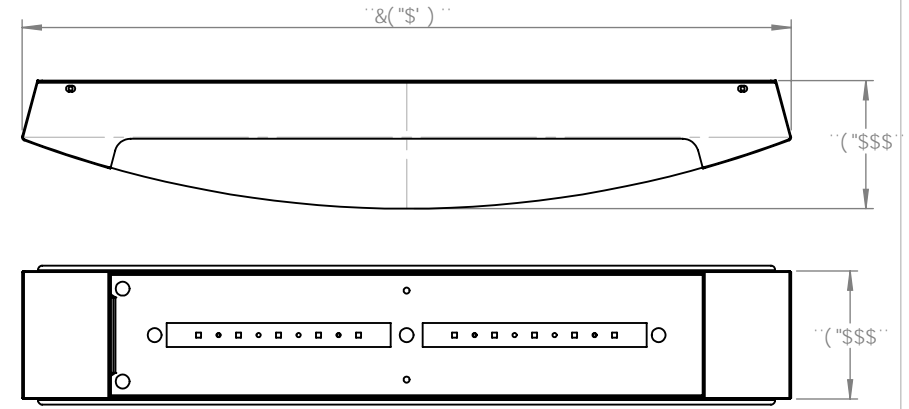

I B @ 9 G C H : 9 F K @ 9 D 9 7 @ 9 8 .	B 5 A 9	8 5 H 9	
8 A 9 B G C B G 5 F 9 B B 7 < 9 G H C @ F 5 B 7 9 G : F 5 7 H C B 5 @ ± "\$ \$" 5 B ; I @ 5 F : A 5 7 < ± "\$ % " 6 9 B 8 ± H K C D @ 5 7 9 8 9 7 A 5 @ ± "\$ \$ % H : F 9 9 D @ 5 7 9 8 9 7 A 5 @ ± "\$ \$ %	8 F 5 K B 7 < 9 7 ? 9 8 9 B ; 5 D D F " A : ; 5 D D F "		H # @ .  C L J B M % & K ! A B ! K : ! & ( m i ( % ?
B H F D F 9 H : 9 C A 9 F 7 H C @ F 5 B 7 B ; D 9 F . A 5 H F 5 @	E " 5 " 7 C A A 9 B H G		G A 9 8 K ; " " B C " F 9 J
: B @ <			<b>5</b> H 7 ? 9 H & ' ' ) (
5 @ @ 6 9 B 8 F 5 8 ± G " \$ " \$ "			G 7 5 @ . % * K 9 ÷ < H ' G < 9 9 H % C : +
5 D D @ 7 5 H C B	8 C B C H G 7 5 @ 9 8 F 5 K B :		

) ( ' % & %

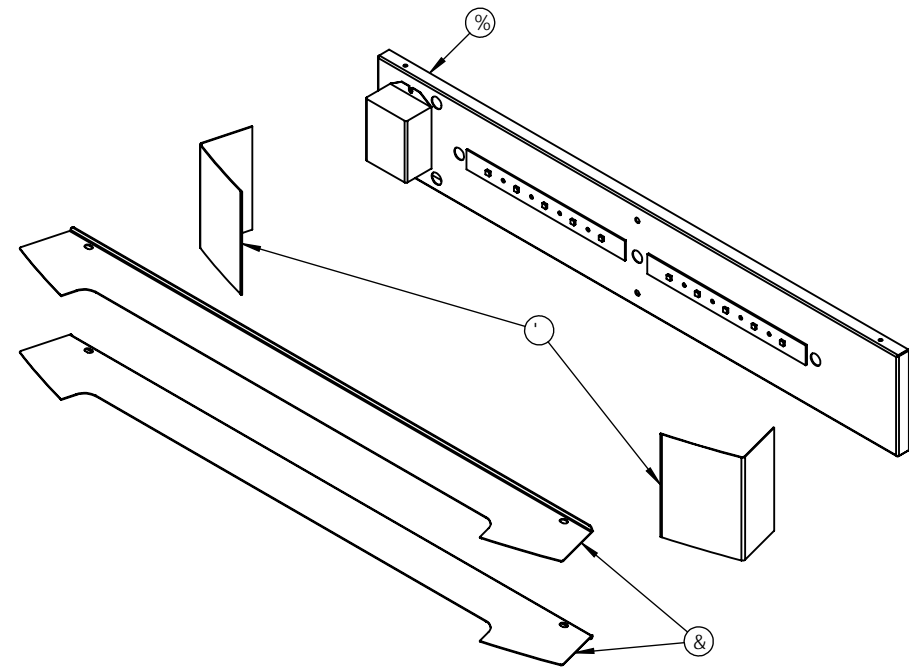
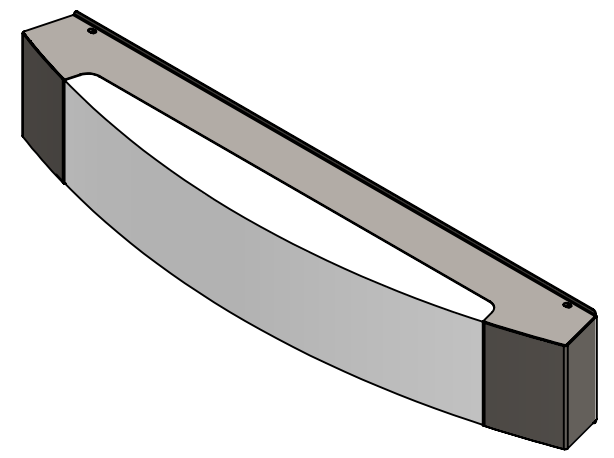
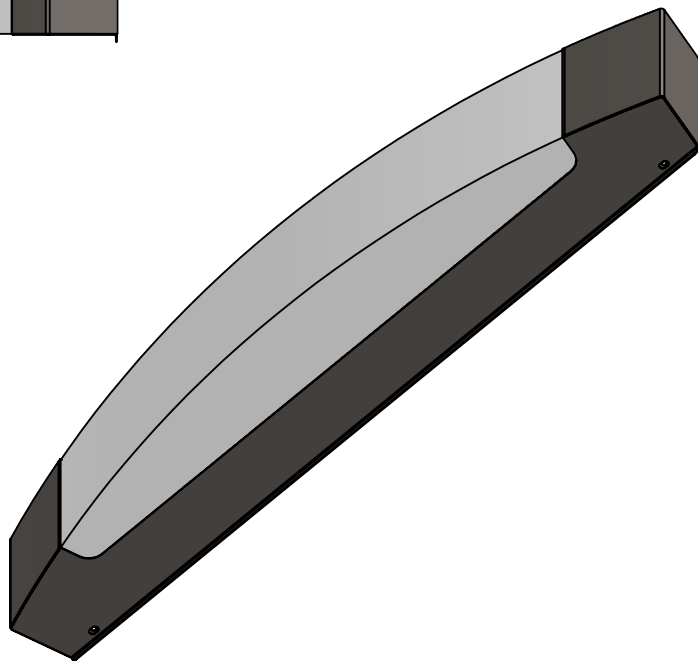
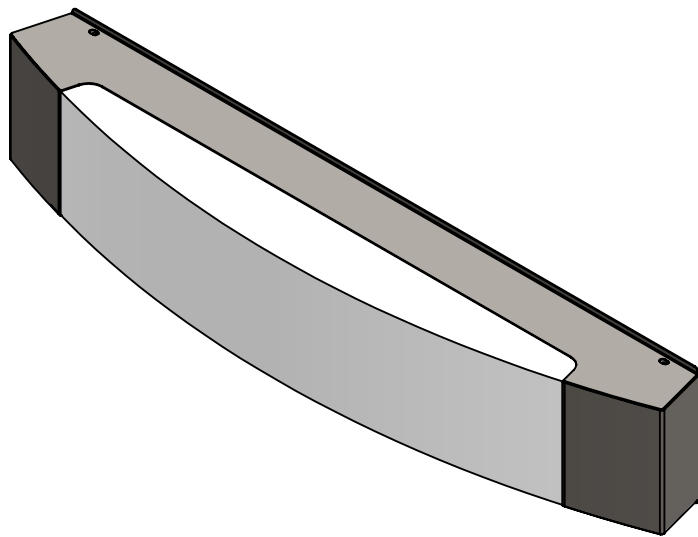
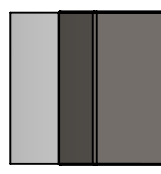

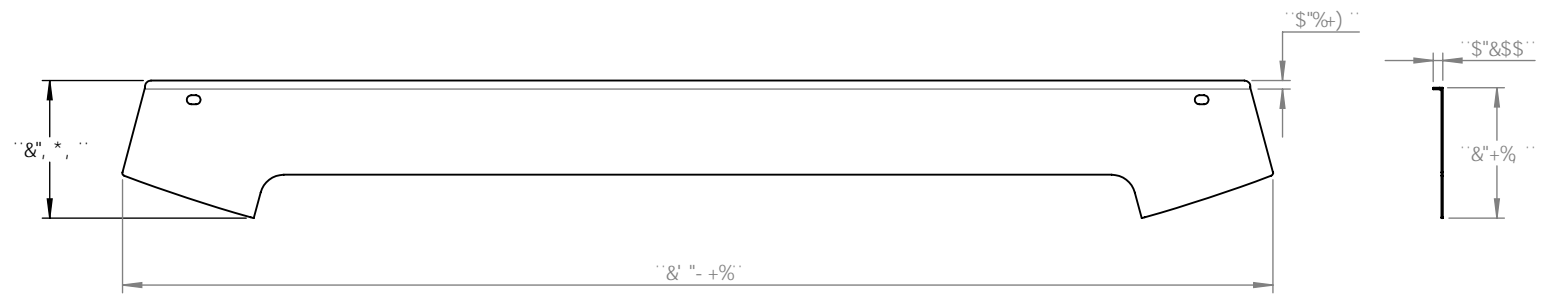
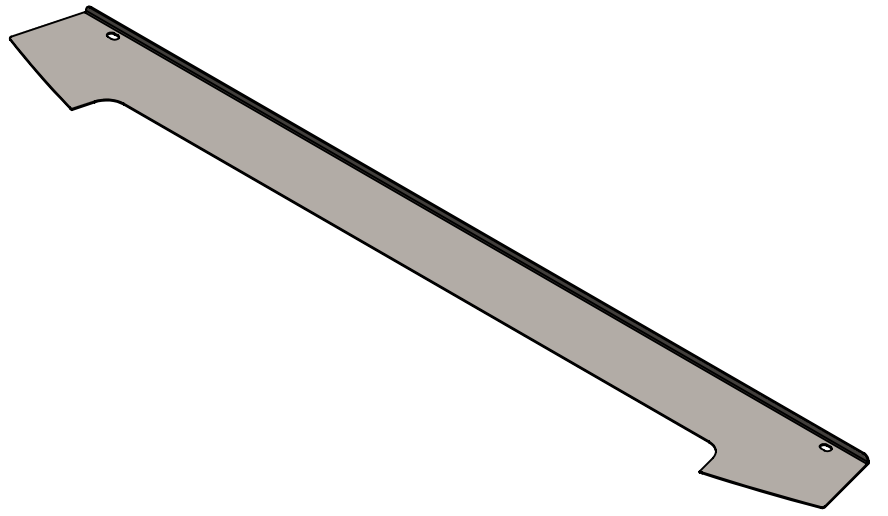

**DFC DF-96 FM5B87CB: 89BH5@**  
 H-9-B: CFA 5HC B 7 C BH5 B 98 B H-6  
 8F5K B: 6H-9GC @DFC D9F HMC:  
 OB 9FH7 CA D5BMB5A 9<9F 92" 5BM  
 F9DFC 8I 7HC B-B D5FHC F 5G5 K <C @  
 K H-C I H-9 K F H-9B D9FA 6GC B C:  
 OB 9FH7 CA D5BMB5A 9<9F 92 G  
 DFC <6H98\*

		I B @GGC H: 9FK 69 GD97 ÷ 98.	B5A 9	85H9	&&; 5I; 9	
		8-A 9BG C BG5F9-B B7 <9G HC @F5B7 9G : F57 HC B5 @± 5B; I @5F: A 57 <± ..... 69B8 ± HK C D @57 9897 A 5@ ± ± HK F99D @57 9897 A 5@ ± ±	8F5K B		H#@.	
		B H9FDF 9H: 9C A 9F 7 HC @F5B7 B: D9F.	7 <97 ?98		CLJBM%&K !A BIK : !&( m(i( %?	
		A 5H9F 5@	9B: 5DDF"			
B9LH5GGM	I G98 CB	: B 6<	A : 5DDF"		G A 9 8K ; "BC"	F9J
	5DD@7 5HC B	8C BCHG75 @98F5K B:	E "5"		5	
			7 C A A 9BHG			G7 5 @. % ( K 9 ÷ <H'

) ( ' & %

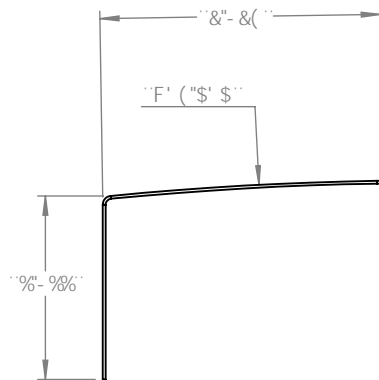
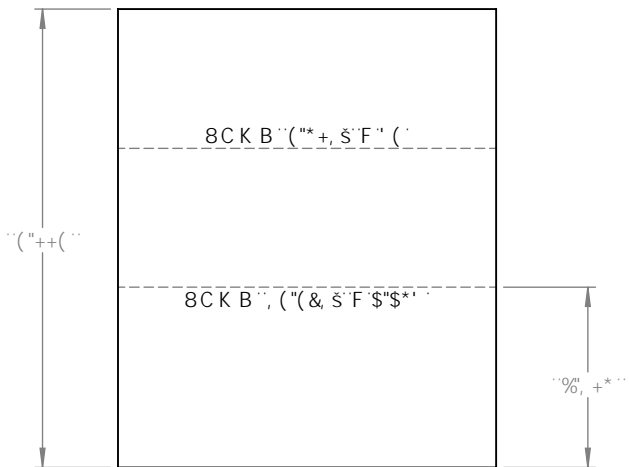
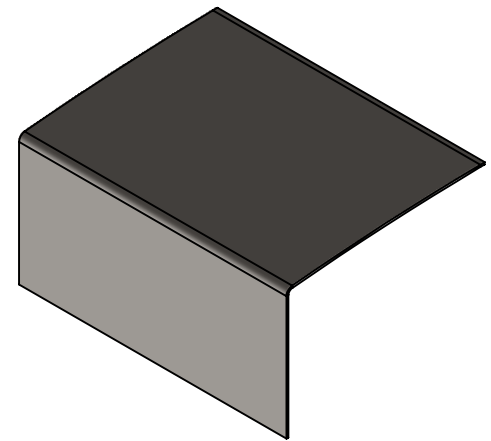
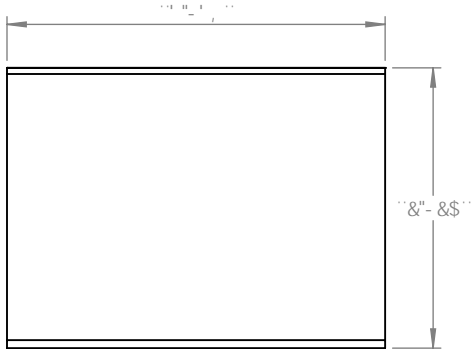

DFC DF-96FM5B87CB: 89BH5@  
 H-9-B: CFA 5HC B 7 C B H5 B 98 B H-6  
 8F5K B: 6H-9GC @DFC D9FHMC:  
 O B 9FH7 CA D5BMB5A 9<9F92 5BM  
 F9DFC 81 7HC B-B D5FHCF 5G5 K <C @  
 K H-C I Hk 9K F H9B D9FA GGC B C:  
 O B 9FH7 CA D5BMB5A 9<9F92 6  
 DFC <6H98\*

		I B @GGCH: 9FK 69 GD97 ÷ 98.	B5A 9	85H9	8&; 5I ; 9	
		8-A 9BG@BG5F9-B B7<9G HC @F5B7 9G : F57 HC B5@± 5B: I @5F: A 57 <± .....69B8 ± HK C D@57 9897 A 5@± HkF99D@57 9897 A 5@±	8F5K B			H#@.
		BH9DF9H: 9CA 9F 7 HC @F5B7 B: D9F.	7 <97 ?98		CLJBM%&K !A B!K : !&( m(i (%?	
		A 5H9F 5@	9B: 5DDF"			
B9LH5GGM	I G98 CB	: B@<	A: 5DDF"		G#9 8K ; ""BC "	F9J
	5DD@7 5HC B	8C BCHG75 @98F5K B:	E "5"		G7 5 @. %& K 9 ÷ <H'	G<99H( 'C: '+
			7 C A A 9BHG			

)

(

&

%

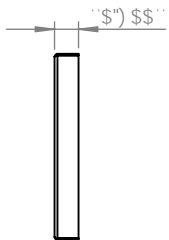
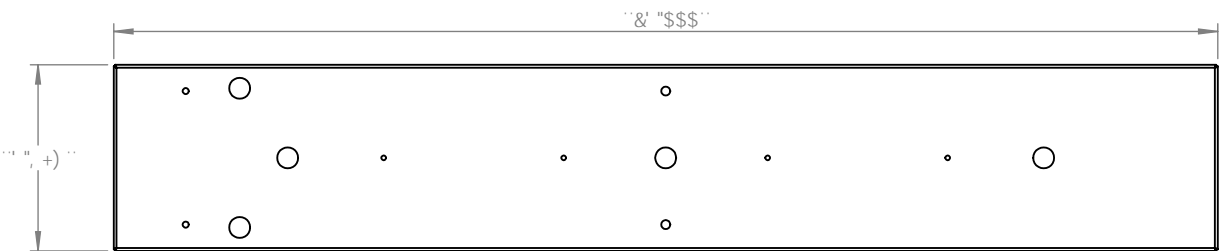
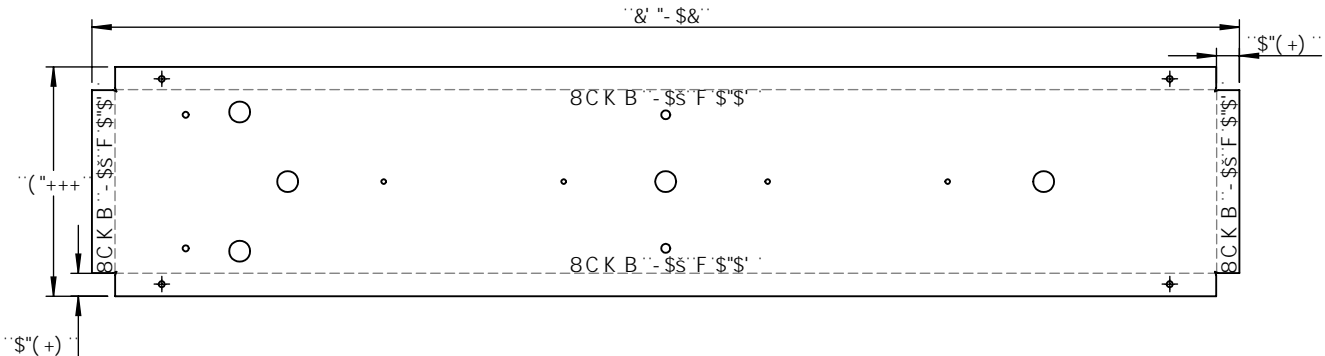
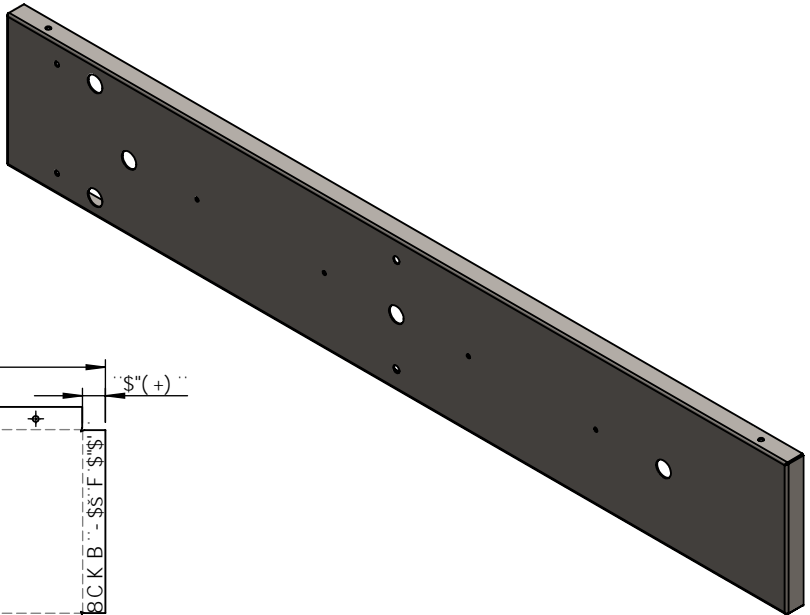

**DFC DF-96FM5B87CB: 89BH5@**  
 H:9 B: CFA 5HC B 7 C BH5 B98 B H:6  
 8F5K B: 6H:9GC @DFC D9FHMC:  
 OB G9FH7 CA D5BMB5A 9 < 9F 92" 5BM  
 F9DFC 81 7 HC B B D5FHCF 5G5 K < C @  
 K H: C I H: 9K F H9B D9FA GGB C:  
 OBG9FH7 CA D5BMB5A 9 < 9F 92 G  
 DFC < 6H98"

		I B @GGCH:9FK 69 GD97 ÷ 98.	B5A 9	85H9	&& ; 51 ; 9	
		8 A 9BG C BG5F9 B B7 < 9G HC @F 5B7 9G ; F57 HC B5 @± 5B: I @5F: A 57 < ± ..... 69B 8 ± HK C D @5 7 9 8 97 A 5 @ ± ± HK F99 D @5 7 9 8 97 A 5 @ ± ±	8F5K B			H # @.
		B H9F DF 9H: 9C A 9F 7 HC @F 5B7 B: D9F.	7 < 97 ? 98		CLJBM % & K ! A B ! K : ! & ( m i ( % ?	
		A 5 H9F 5 @	9B: 5DDF"			
	B9LH5GGM	I G98 C B	A: 5DDF"		G A 9 8 K ; " " BC "	F9J
			E "5"		5	
			7 C A A 9BHG			
			: B 6<		G7 5 @. % ( K 9 ÷ < H'	G < 99H) 'C: '+
	5DD @ 7 5HC B	8C B CHG 7 5 @ 9 8F5K B:				

)

(

,

&

%