

#PA BC "	D5FHBI A 69F	89G7 F-DHC B	E HM	7 I H
%	6C @&D(F!) @8!-!7 5!& L%\$! : FC BHD@H	5@ A -B I A "\$%&)" "D@H	&	
&	6C @&D(F!) @8!-!7 5!& L%\$! : G8 9G D@H	5@ A -B I A "\$%&)" "D@H	&	
'	6C @&D(F!) @8!-!7 5!& L%\$! : HC D'D@H	5@ A -B I A "\$%&)" "D@H	%	
(6C @&D(F!) @8!-!7 5!& L%\$! : C D9B GD57 9HC D'D@H	5@ A -B I A "\$%&)" "D@H	%	
)	6C @&D(F!) @8!-!7 5!& L%\$! : C D9B GD57 96C HC A D@H	5@ A -B I A "\$%&)" "D@H	%	
*	6C @&D(F!) @8!-!7 5!& L%\$! : C D9B GD57 9G8 9D@H	5@ A -B I A "\$%&)" "D@H	&	
+	6C @&D(F!) @8!-!7 5!& L%\$! : F 9D@H	5@ A -B I A "\$%&)" "D@H	%	
,	6C @&D(F!) @8!-!7 5!& L%\$! : HC D'D@H 6F57?9H	5@ A -B I A "\$\$*\$)" "	%	
-	6C @&D(F!) @8!-!7 5!& L%\$! : @8 6F57?9H	5@ A -B I A "\$\$*\$)" "	%	
%\$	6C @&D(F!) @8!-!7 5!& L%\$! : 8C C F	5@ A -B I A "\$\$*\$)" "	%	
%%	6C @&D(F!) @8!-!7 5!& L%\$! : 8F J 9F 6C L	5@ A -B I A "\$\$*\$)" "	%	
%%&	6C @&D(F!) @8!-!7 5!& L%\$! : 8F J 9F 7 5 D	5@ A -B I A "\$\$*\$)" "	%	
%	6C @&D(F!) @8!-!7 5!& L%\$! : GC 7?9H6F57?9H	5@ A -B I A "\$\$*\$)" "	%	
%(6C @&D(F!) @8!-!7 5!& L%\$! : 7 C J 9F H 5 6	&) : 5! : 9	(
%)	6C @&D(F!) @8!-!7 5!& L%\$! : 57 FM@7	57 FM@7	%	
%*) \$ A A < 95 HG B ?	< 95 HG B ?	%	
%+	: i \ Ua H c f c @8 S H A % B J \$ ') \$ % @ % \$ \$ + + j	8 F J 9 F	%	
%	5 H U @8 SD 7 B S 8 % \$ \$ \$ \$ \$) 6	@8	%	

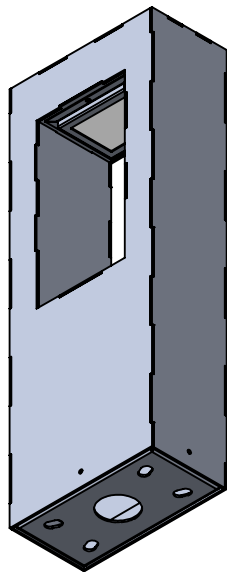
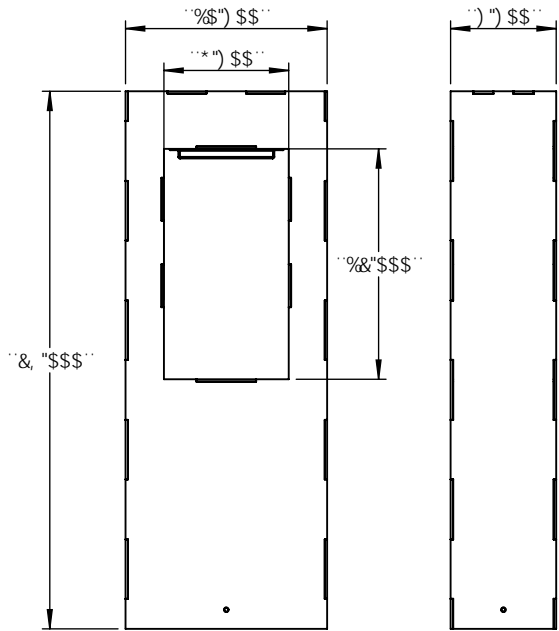
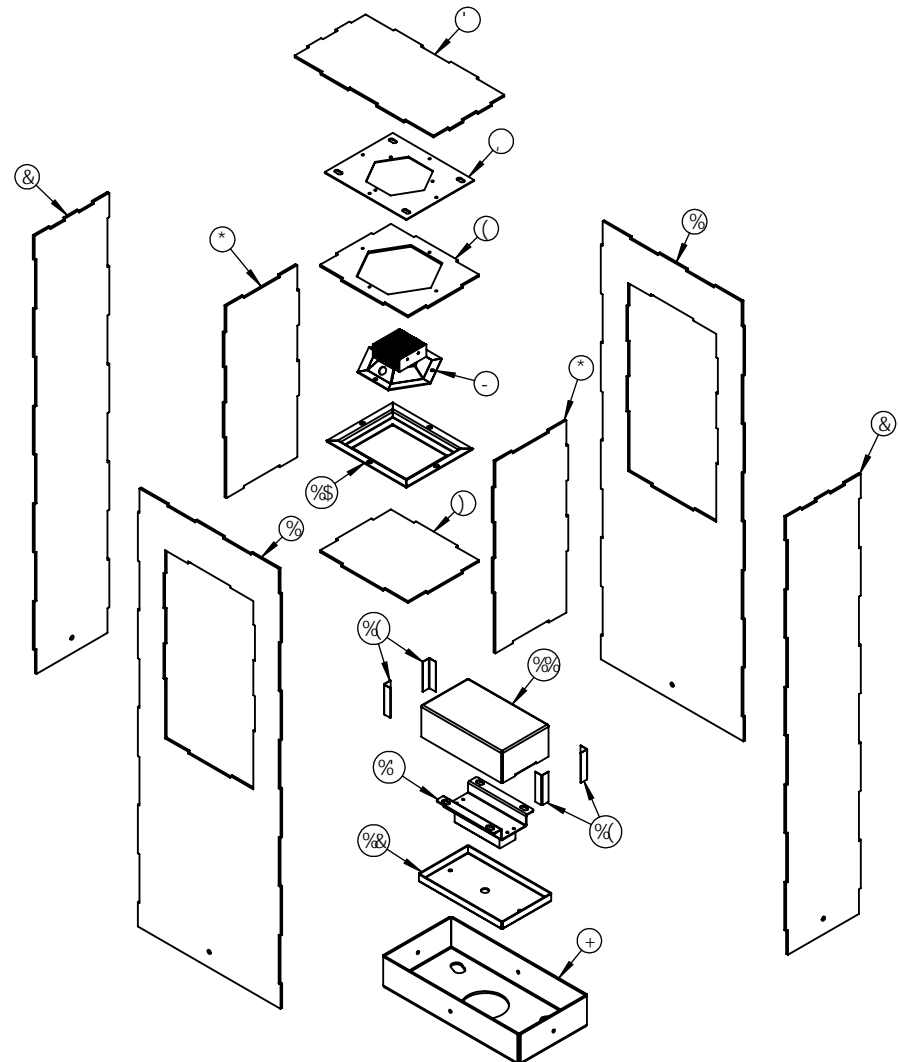

I B @GGC H: 9FK @9 GD97 @ 98.		B5A 9	85H9
8 A 9BG@ BG5F9 B -B7 < 9G HC @F5B7 9G : F57 HC B5 @± "\$\$" 5B: I @F: A 57 < ± "\$\$"" 69B 8 ± HK C D@57 9897 A 5@ ± "\$\$" H:F99D@57 9897 A 5@ ± "\$\$"	8F5K B 7 < 97 ? 98 9B: 5DDF" A: 5DDF"		
B:H@FDF 9H: 9C A 9F 7 HC @F5B7 B: D9F. A 5H@F 5@	E "5" 7 C A A 9BHG		
: B @<			
8C B@HG7 5@8F5K B:			

H#@.

6C @&D(F!) @8!-!7 5!& L%\$

G#9	8K ; ""BC "	F9J
5	H7 ? 9H&' (- \$	
G7 5 @. % % \$ K 9 ÷ < H'		G< 99H% C : ;



EVERGREEN LIGHTING

5 @@69B8 'F58 ÷ G" \$' \$ "

5DD@7 5HC B

8C B@HG7 5@8F5K B:

)

(

&

%

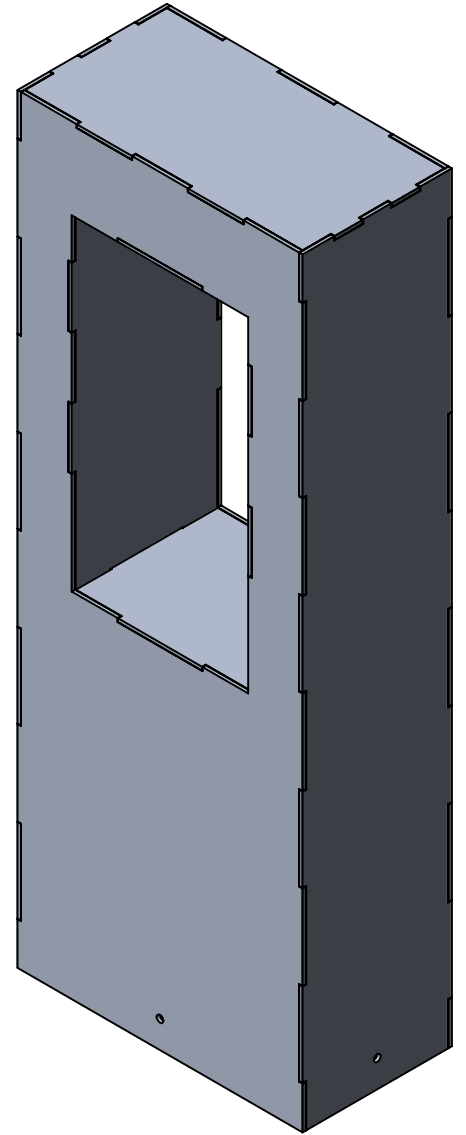
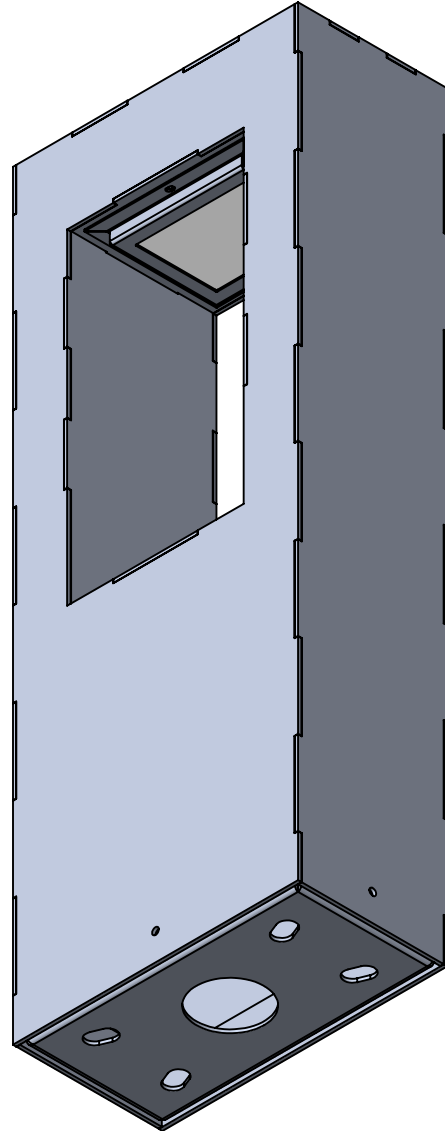
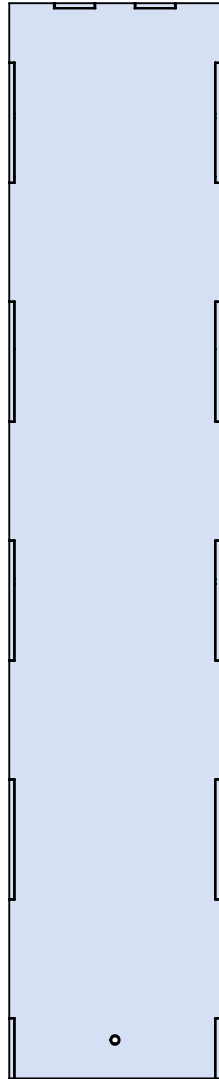
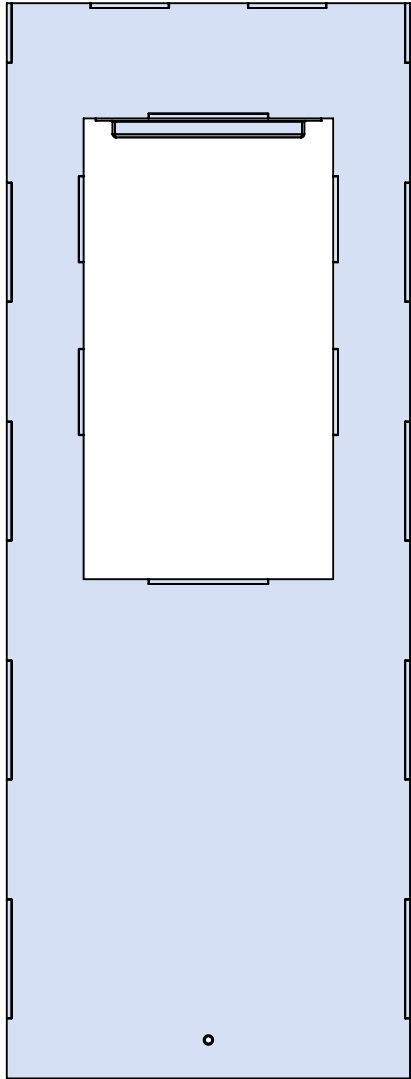

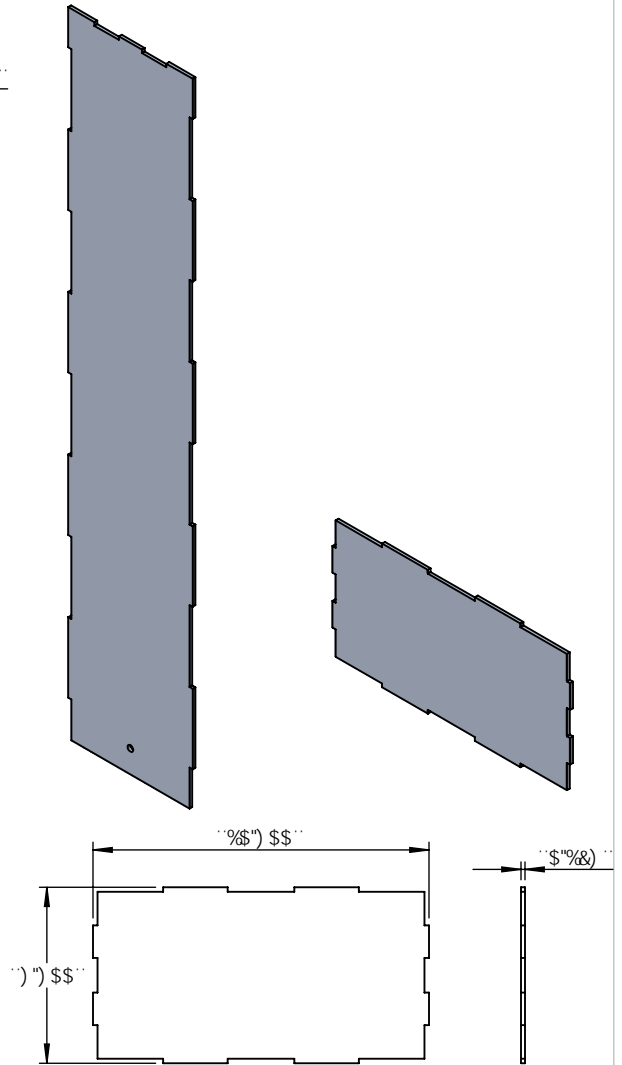
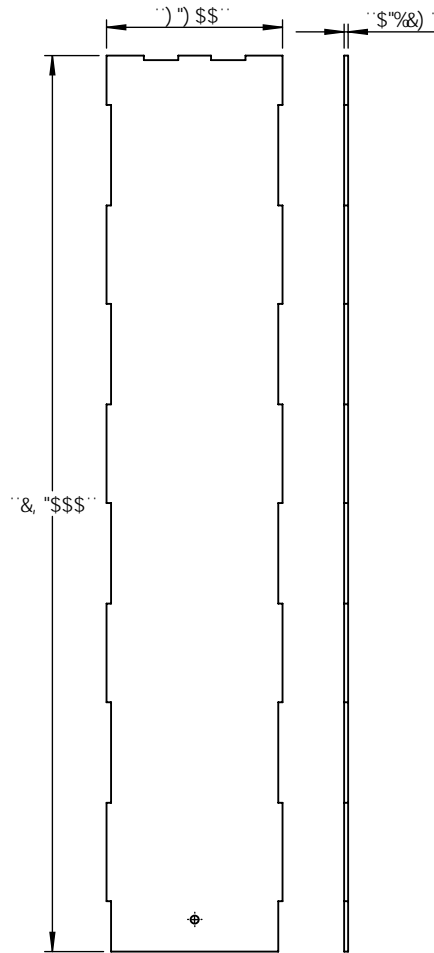
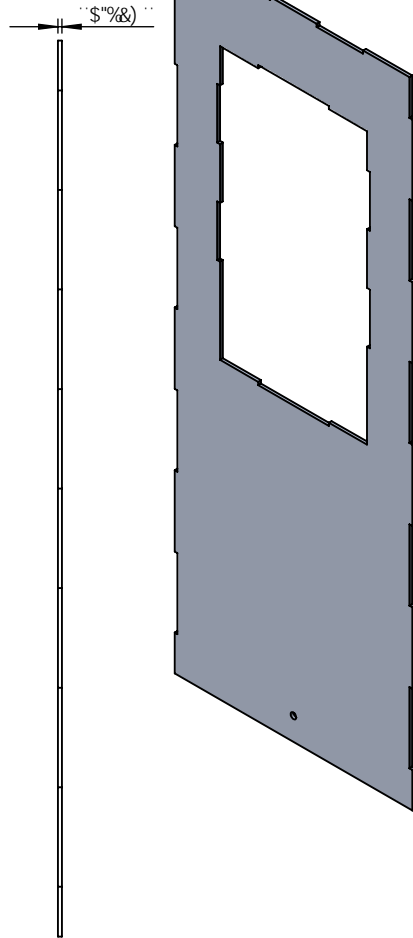
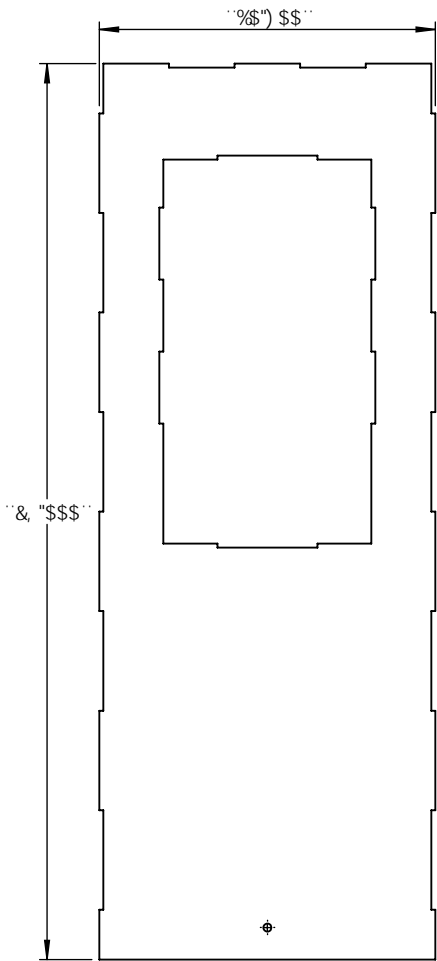

DFC DF-915FM5B87CB: 89BH5@
 H:9 B: CFA 5HC B 7 C B H5 B 98 B H:6
 8F5K B: 6H:9 GC @DFC D9FHMC:
 OBG9FH7 CA D5BMB5A 9<9F92" 5BM
 F9DFC 81 7 HC B B D5FHCF 5G5 K <C @
 K H:C I H:9 K F H9B D9FA 6GC B C:
 OBG9FH7 CA D5BMB5A 9<9F92 6
 DFC <6H98"

		I B @GGCH:9FK 69GD97 ÷ 98.		B5A 9	85H9
		8 A 9BG@BG5F9 B B7 <9G HC @F5B7 9G :F57 HC B5 @± 5B: I @5F: A 57 <±69B8 ± HK C D@579897 A 5@±± H:K F99D@579897 A 5@±	8F5K B 7 <97 ?98 9B: 5DDF" A: : 5DDF" E "5" 7 C A A 9BHG		
		B H9FDF9H: 9C A 9FF 7 HC @F5B7 B: D9F. A 5H9F 5@			
B9LH5GGM	I G98 CB	: B 6<			
	5DD@7 5HC B	8C B CHG75 @98F5K B:			

5 @ A B I A "\$"%) "'D@5H9		
H#@.		
6C @&D@F!) @98!-!7 5!&, L%\$		
G#9 5	8K ; "'BC"	F9J
G7 5 @. % *	K 9 ÷ <H'	G<99H' 'C : ,

)

(

&

%

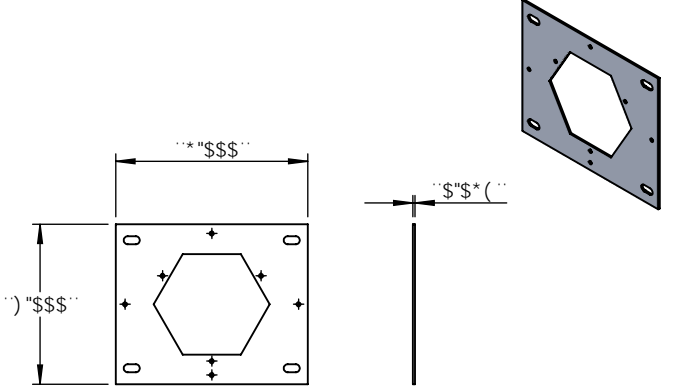
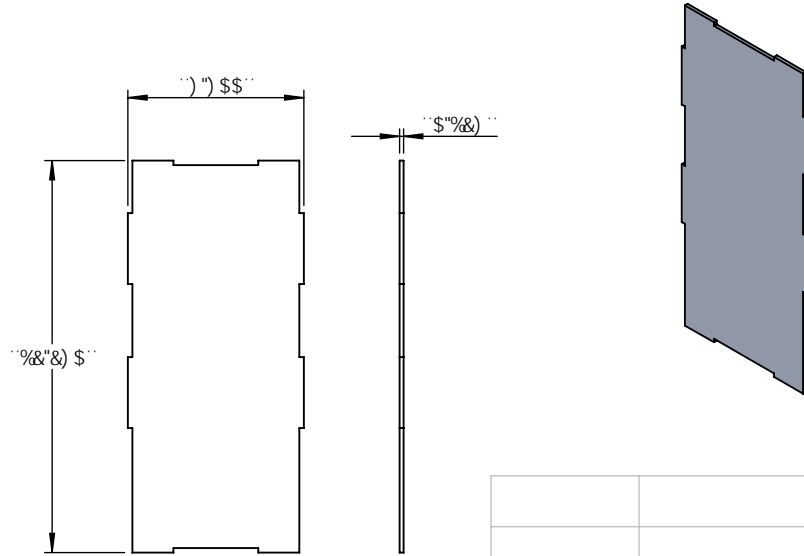
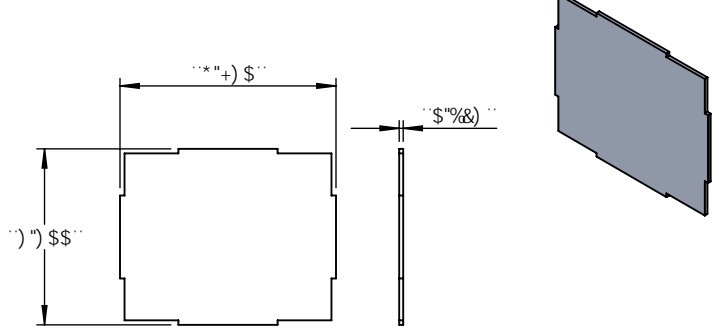
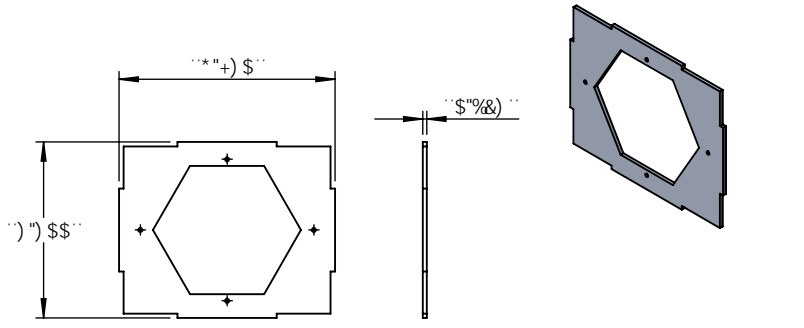

DFC DF-915FM5B87CB: 89BH5@
 H:9 B: CFA 5HC B 7 C B H5 B 98 B H:6
 8F5K B: 6H:9GC @DFC D9F HVC:
 OBG9FH7CA D5BMB5A 9<9F92" 5BM
 F9DFC 81 7HC B-B D5FHCF 5G5 K <C @
 K H:C1 H:9K F H9B D9FA 6GC B C:
 OBG9FH7CA D5BMB5A 9<9F92 6
 DFC <6H98"

		I B @GGCH:9FK 69GD97 ÷ 98.	B5A 9	85H9	5 @ A B I A '\$"%&)" "D@5H9
		8 A 9BGC BG5F9 B B7 <9G HC @F5B7 9G :F57 HC B5 @± 5B: I @5F: A 57 <± "69B8 ± HK C D@57 9897 A 5@± H:F99D@57 9897 A 5@±	8F5K B		H#@.
		B H9FDF 9H: 9C A 9FF 7 HC @F5B7 B: D9F.	7 <97 ?98		6C @&D@F!) @98!-!7 5!&, L%\$
		A 5H9F 5@	9B: 5DDF"		
		:B 6<	A: : 5DDF"		
			E "5"		
			7 C A A 9BHG		
B9LH5GGM	I G98 CB				G#9 8K ; "'BC" F9J
5DD@7 5HC B	8C BCHG75 @98F5K B:				G7 5 @. %* K 9 ÷ <H' G<99H('C: ;

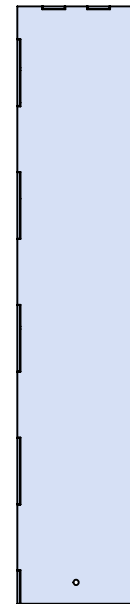
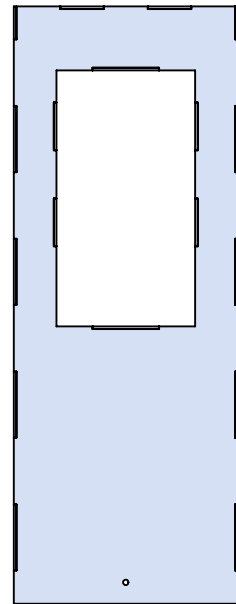
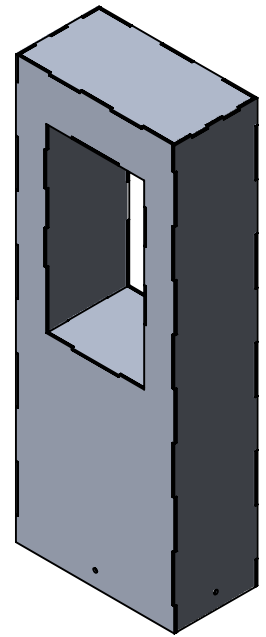
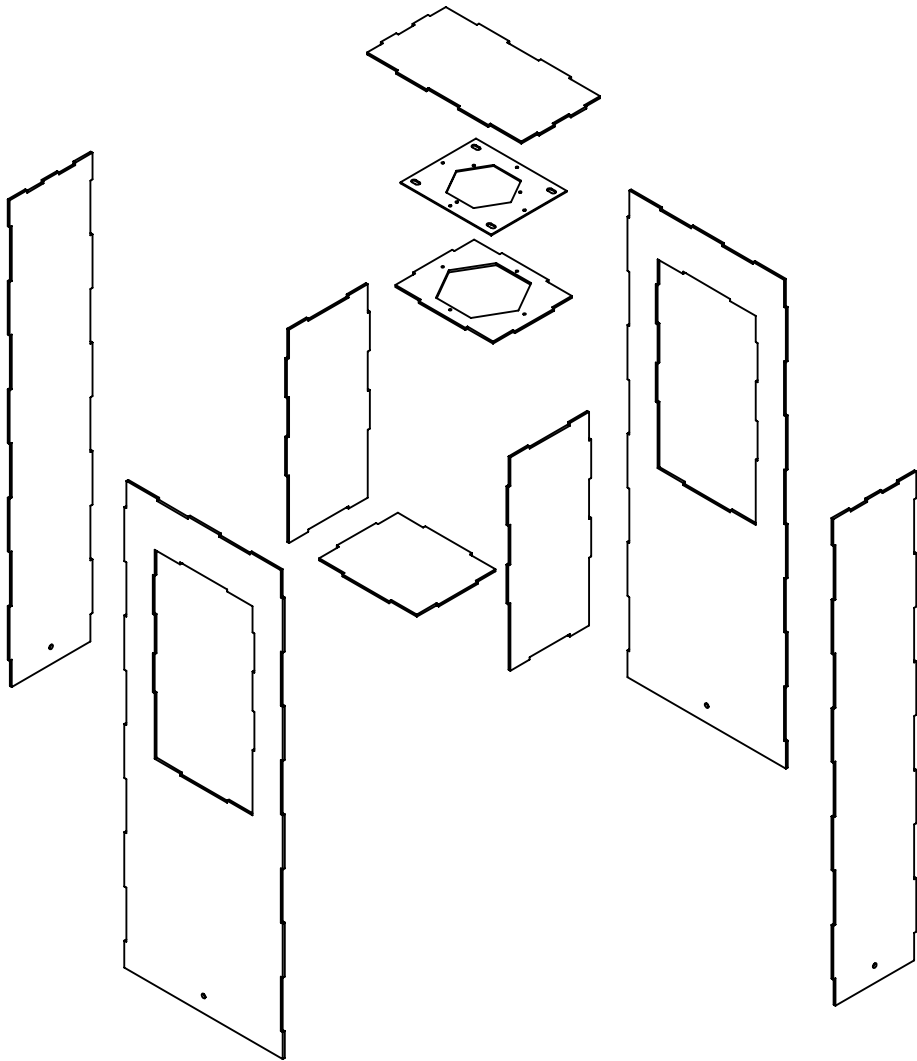

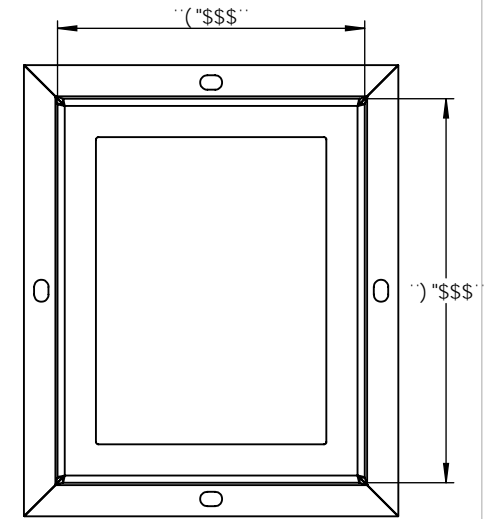
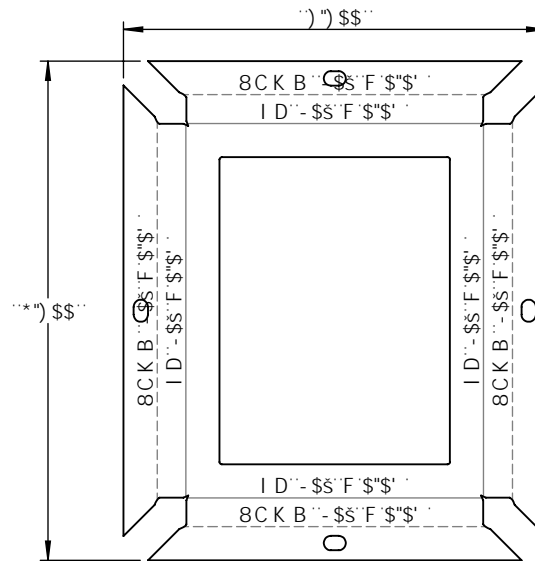
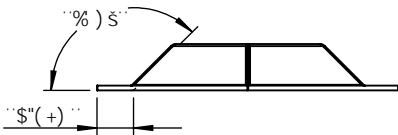
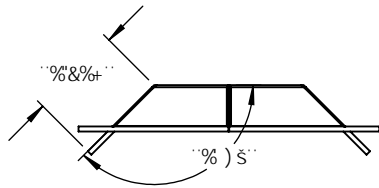
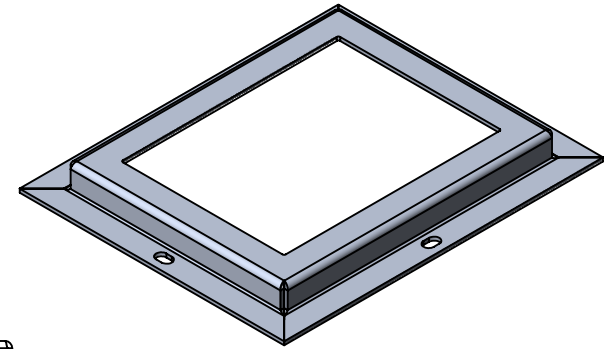
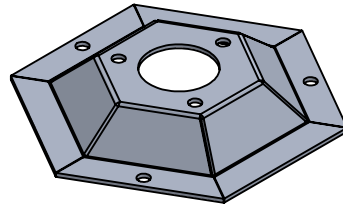
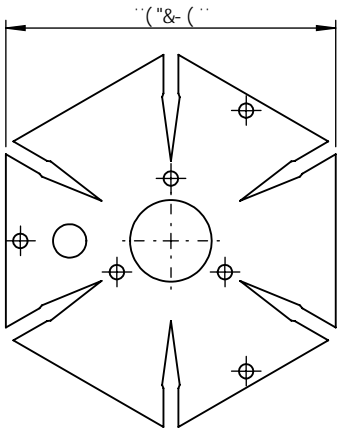

DFC DF-915FM5B87CB: 89BH5@
 H:9 B: CFA 5HC B 7 C B H5 B 98 B H:6
 8F5K B: 6H:9GC @DFC D9FHVC:
 OBG9FH7 CA D5BMB5A 9<9F92" 5BM
 F9DFC 81 7 HC B B D5FHCF 5G5 K <C @
 K H:C1 H:K 9K F H9B D9FA 6GC B C:
 OBG9FH7 CA D5BMB5A 9<9F92 6
 DFC <6H98"

		I B @GGCH:9FK 69GD97 ÷ 98.		B5A 9	85H9
		8A 9BG C BG5F9 B B7 <9G HC @F5B7 9G : F57 HC B5 @± 5B: I @F: A 57 <±69B8 ± HK C D@57 9897 A 5@± H:F99D@57 9897 A 5@±	8F5K B 7 <97 ?98 9B: 5DDF" A: : 5DDF"		
		BH9DF9H: 9CA 9FF 7 HC @F5B7 B: D9F.	E "5" 7 C A A 9BHG		
		A 5HF 5@			
B9LH5GGM	I G98 CB	: B<			
	5DD@7 5HC B	8C B CHG75 @98F5K B:			

5 @ A B I A "\$\$*') "		
H#@.		
6C @&D@F!) @98!-!7 5!& L%		
G#9 5	8K ; ""BC"	F9J
G7 5 @. %&") K 9 ÷ <H'	G<99H* 'C : ;	

)

(

&

%

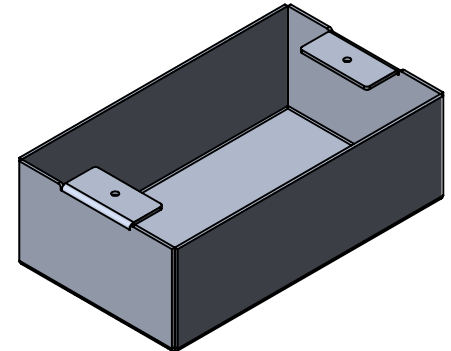
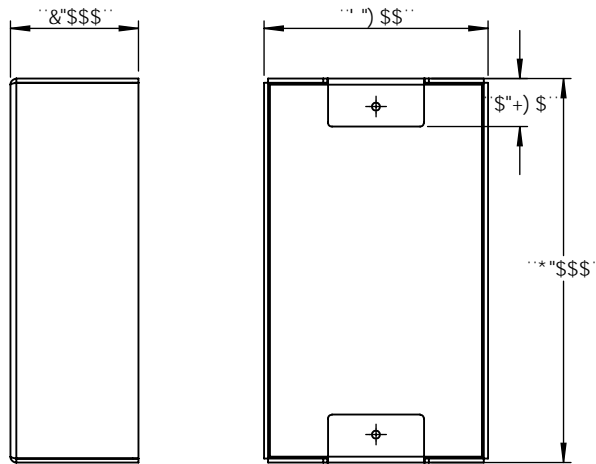
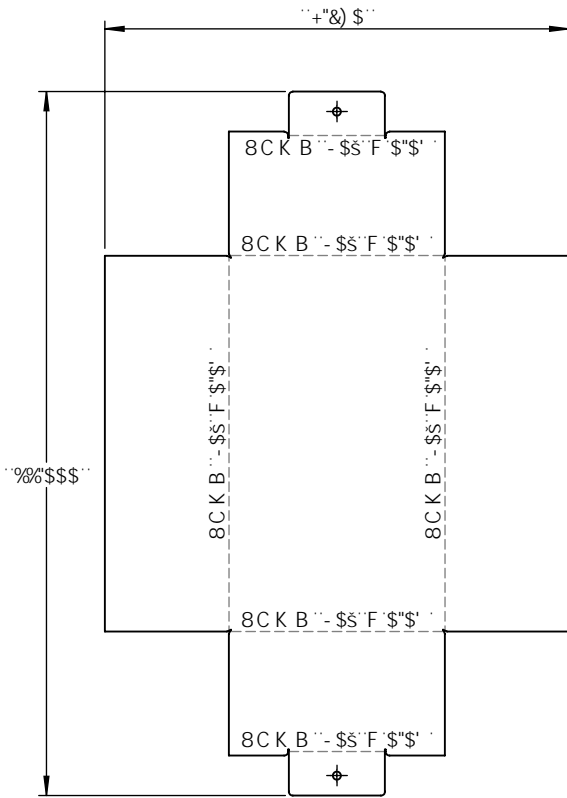
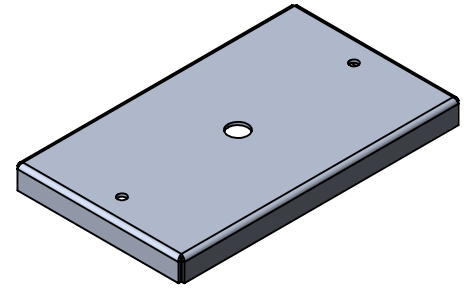
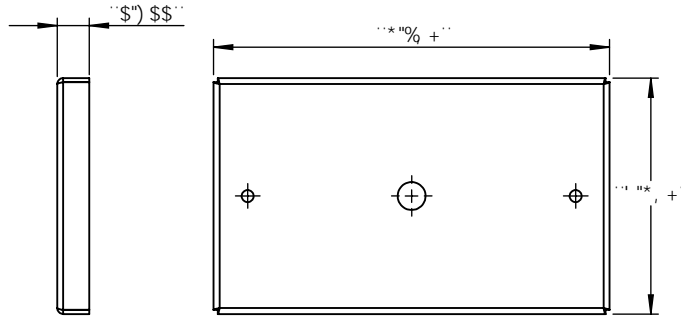
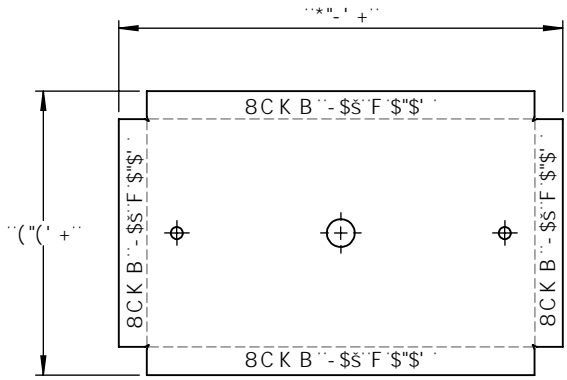

DFC DF 5FM5B87CB: 89BH5@
 H:9 B: CFA 5HC B 7C B15 B98 B H:6
 8F5K B: 6H:9GC @DFC D9FHVC:
 OB9FH7CA D5BMB5A 9<9F92" 5BM
 F9DFC 817HC B-B D5FHCF 5G5K <C@
 K H:C1 H:9K F H9B D9FA 6GB C:
 OB9FH7CA D5BMB5A 9<9F92 6
 DFC <6H98"

B9LH5GGM

I G98 CB

5DD@7 5HC B

I B @GGCH:9FK 69GD97 ÷ 98.

8A 9BGC BG5F9 B B7 <9G
 HC @F5B7 9G
 :F57HC B5@±
 5B: I @F: A 57 <±69B8 ±
 HK C D@579897 A 5@±
 H:F99D@579897 A 5@±

BH9DF9H: 9CA 9FF 7
 HC @F5B7 B: D9F.

A 5HF 5@

:B<

8C BCHG75@8F5K B:

B5A 9

85H9

8F5K B

7 <97 ?98

9B: 5DDF"

A: 5DDF"

E "5"

7 C A A 9BHG

5@ A BIA '\$\$*') "

H#@.

6C @&D@F!) @98!-!7 5!&, L%\$

G#9

5

G7 5 @. %'

8K ; "'BC"

K 9 ÷ <H'

F9J

G<99H+C: ;

)

(

&

%

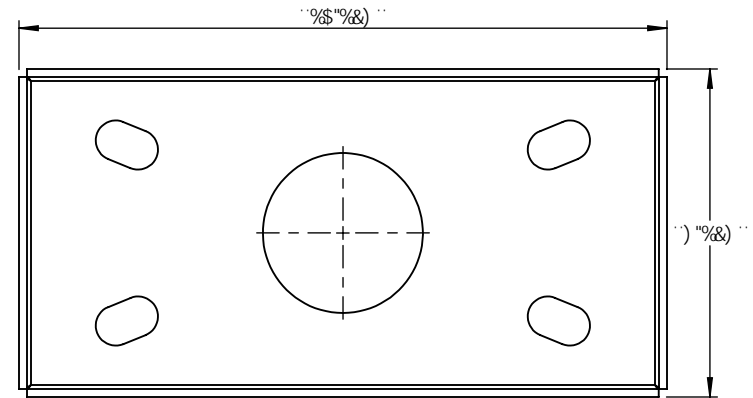
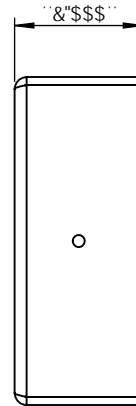
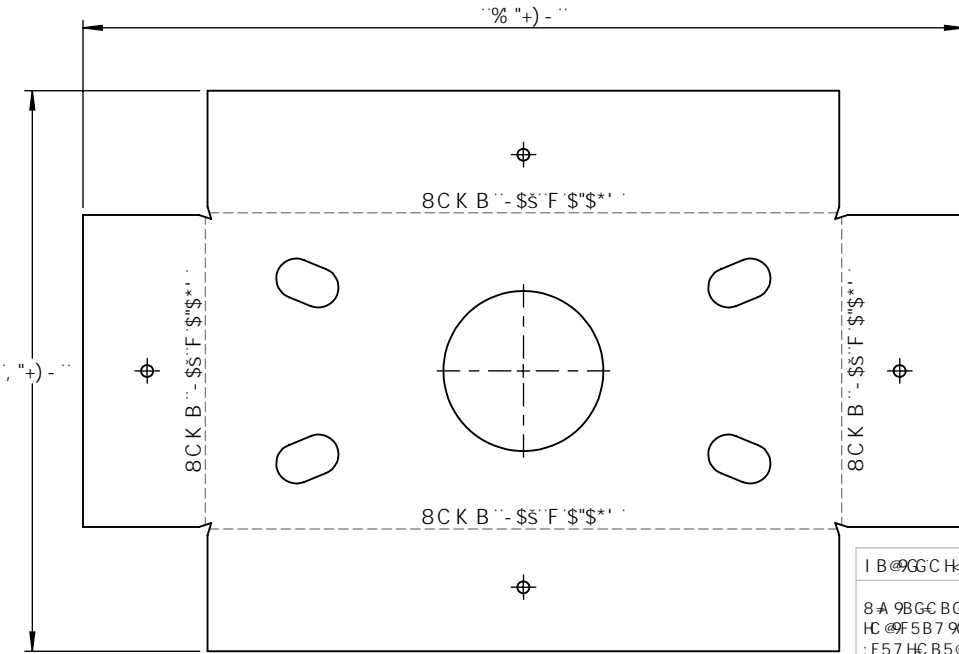
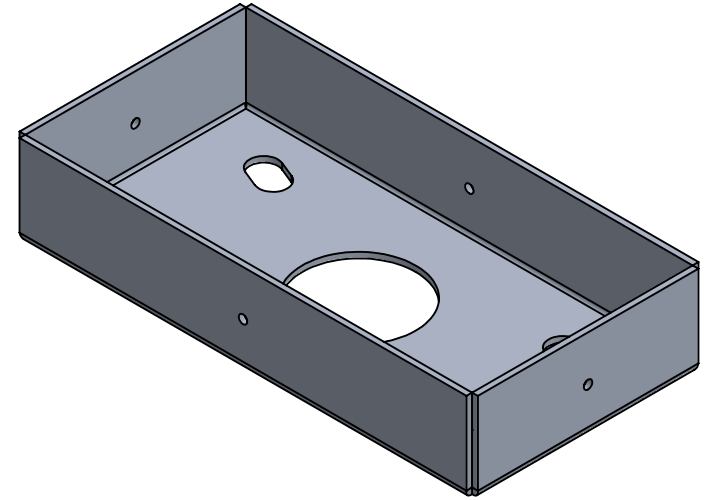
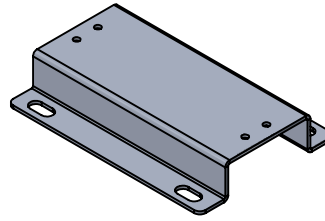
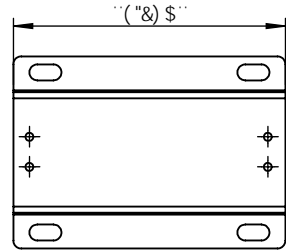
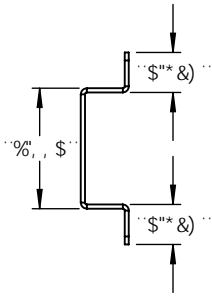
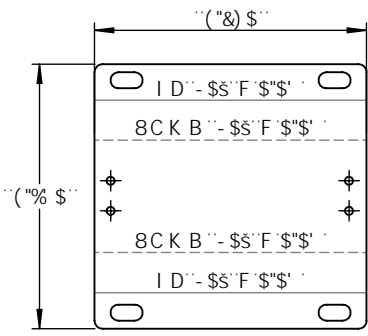

I B @GGC H: 9FK @9 GD97 ÷ 98.

8 A 9BGC BG5F9 B B7 < 9G
 HC @F 5B7 9G
 : F57 HC B5 @±
 5B: I @5F: A 57 < ± 69B8 ±
 HK C D @57 9897 A 5 @ ±
 HKF99D @57 9897 A 5 @ ±

BH@FDF 9H: 9C A 9F 7
 HC @F 5B7 B: D9F.

A 5H@F 5 @

: B @<

8C B@H7 5 @98F5K B:

B5A 9

85H@

5 @ A B I A '\$\$*') "

H#@.

6C @&D@F!) @98!-!7 5!&, L%

DFC DF-9 5FM5B8 7CB: @9BH5 @

H: 9 B: CFA 5HC B 7 C B H5 B 98 B H: 6
 8F5K B: @6H: 9GC @DFC D9FHVC:
 O B @9FH7 C A D5BMB 5A 9 < 9F92" 5BM
 F9DFC 81 7 HC B B D5FHCF 5G5 K < C @
 K H: C I H: 9K F H@B D9FA @GC B C:
 O B @9FH7 C A D5BMB 5A 9 < 9F92 G
 DFC < 6#98"

B9LH5GGM

I G98 C B

5DD@7 5HC B

G@9
5

8K; "BC"

F9J

G7 5 @. %' K 9 ÷ < H'

G < 99H, 'C: ;

)

(

&

%