

I B @GGC H: 9FK 69 GD97 ÷ 98.		B5A 9	85H9	
8 A 9BG C BG5F9 B B7 < 9G HC @F 5B7 9G : F57 HC B5 @± "\$\$" 5B: I @F: A 57 < ± "\$%"" 69B8 ± HK C D@5 7 9897 A 5 @"" ± H: F99D@5 7 9897 A 5 @ ± "\$\$%"	8F5K B			H#@.
	7 < 97 ? 98			
	9B: "5DDF"			J 6C @(\$\$\$\$) \$K !-!K :
	A : "5DDF"			
BH@DF 9H: 9C A 9F 7 HC @F 5B7 B: D9F.	E "5"			
A 5H@F 5@	7 C A A 9BHG			G#9 8K ; ""BC "
				F9J
: B @<				5 H7 ? 9H&' * + \$
5 @69B8 F58 ÷ G "\$" \$"				G7 5 @. % + K 9 ÷ < H'
5DD@7 5HC B	8C B@HG 7 5 @9 8F5K B:			G < 99H % C : % \$

)

(

&

%

#9A BC "	D5FHBI A 69F	89G7 F-DHC B	E HM	7 I H
%	J 6C @(\$mī \$K !-!K :!5B7 <CF 65G9	5@ A -BI A "\$%&)" "D@H9	%	
&	J 6C @(\$mī \$K !-!K :!5B7 <CF D@H9	5@ A -BI A "\$%&)" "D@H9	%	
'	J 6C @(\$mī \$K !-!K :!HC D D@H9	5@ A -BI A "\$%&)" "D@H9	%	
(J 6C @(\$mī \$K !-!K :!<958 G89 D@H9	5@ A -BI A "\$%&)" "D@H9	%	
)	J 6C @(\$mī \$K !-!K :!HC D D@H9 6F57?9H	5@ A -BI A "\$%&)" "D@H9	%	
*	J 6C @(\$mī \$K !-!K :!<958 657? D@H9	5@ A -BI A "\$%&)" "D@H9	%	
+	J 6C @(\$mī \$K !-!K :!H 69:F5A 9	5@ A -BI A "\$%&)" "D@H9	&	
,	J 6C @(\$mī \$K !-!K :!F5A 9 657?G89	5@ A -BI A "\$%&)" "D@H9	&	
-	J 6C @(\$mī \$K !-!K :!HC D @98 6F57?9HD@H9	5@ A -BI A "\$%&)" "D@H9	&	
%\$	J 6C @(\$mī \$K !-!K :!6CHCA @98 6F57?9HD@H9	5@ A -BI A "\$%&)" "D@H9	&	
%%	J 6C @(\$mī \$K !-!K :!@98 D@H9	5@ A -BI A "\$%&)" "D@H9	%	
%&	J 6C @(\$mī \$K !-!K :!@98 8F 9F D@H9	5@ A -BI A "\$%&)" "D@H9	&	
%	J 6C @(\$mī \$K !-!K :!57FM@7 :579	57FM@7	%	
%{(J 6C @(\$mī \$K !-!K :!57FM@7	57FM@7	&	
%)	?H@B!@!! J !D G) \$(& !J 8 A !@D%	8F 9F	%	
%*	?H@B!@!! J !D G) \$(& !J 8 A !@D%	8F 9F	%	
%+	5 'U' @98 SD7 BS8% \$S%\$6!%\$ K 5HH	@98	%	
%	5 'U' @98 DB %\$) 6!%\$GG	@98	(

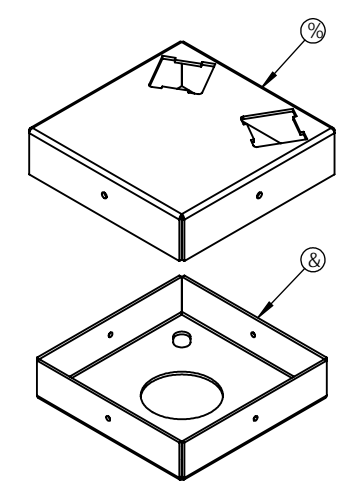
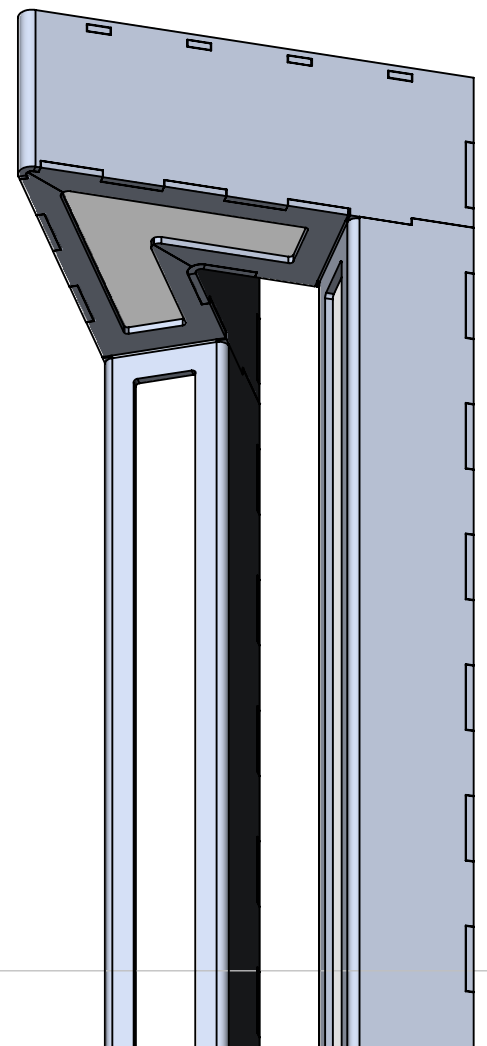
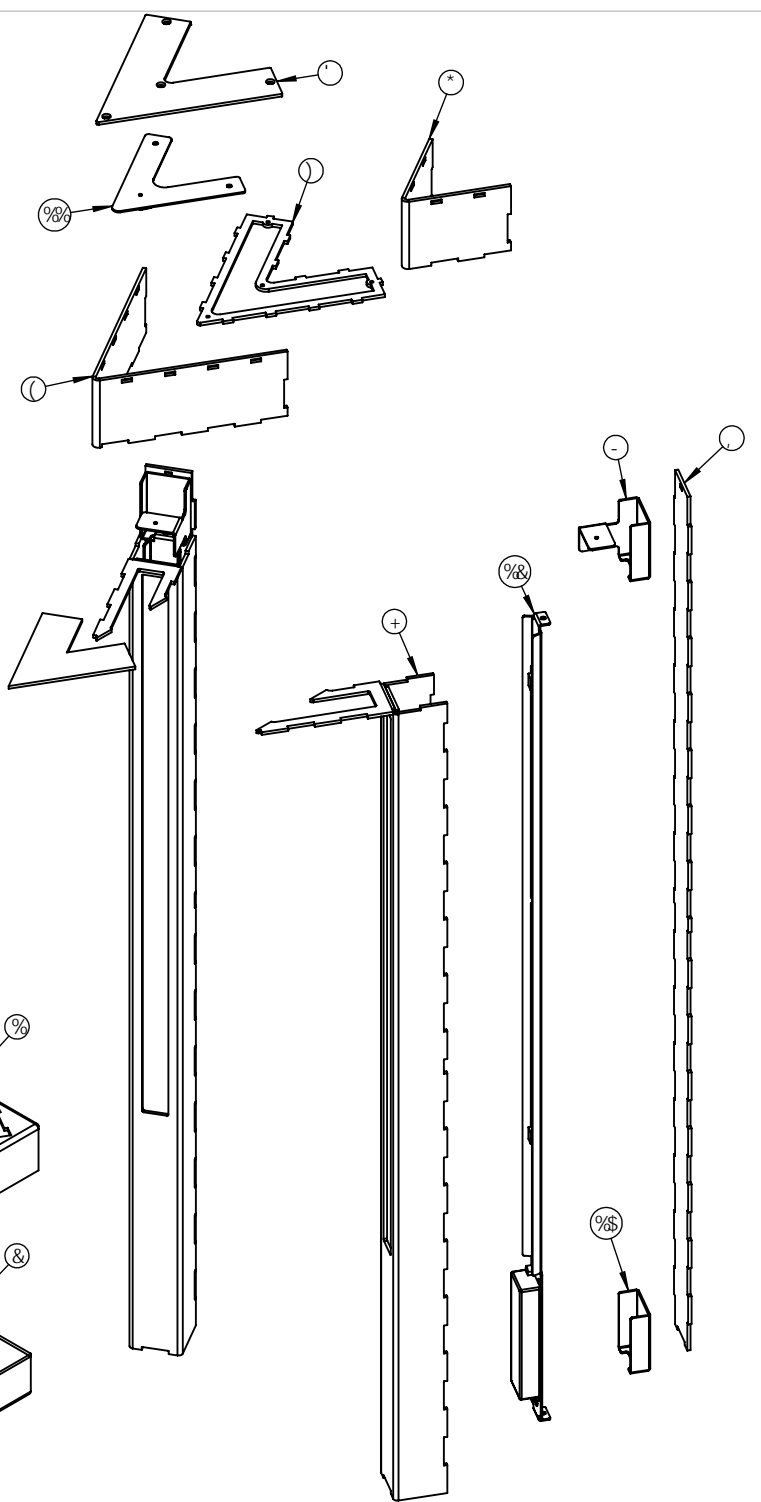

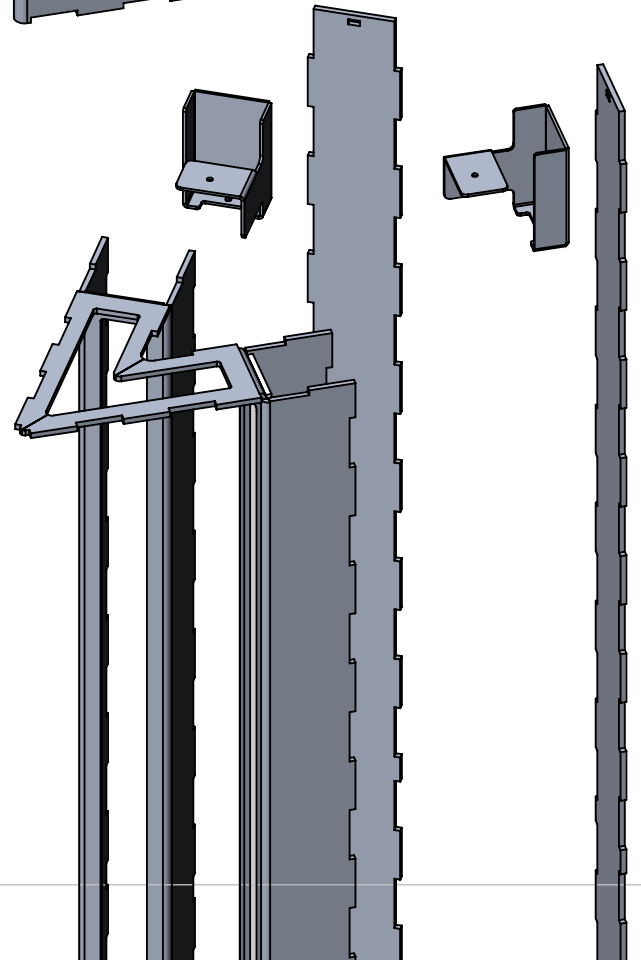
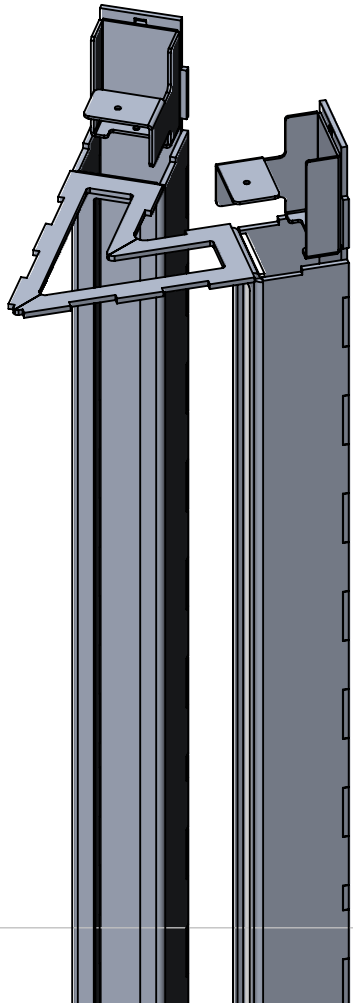
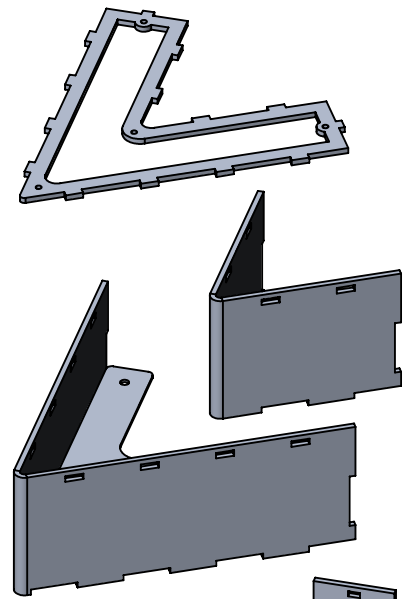
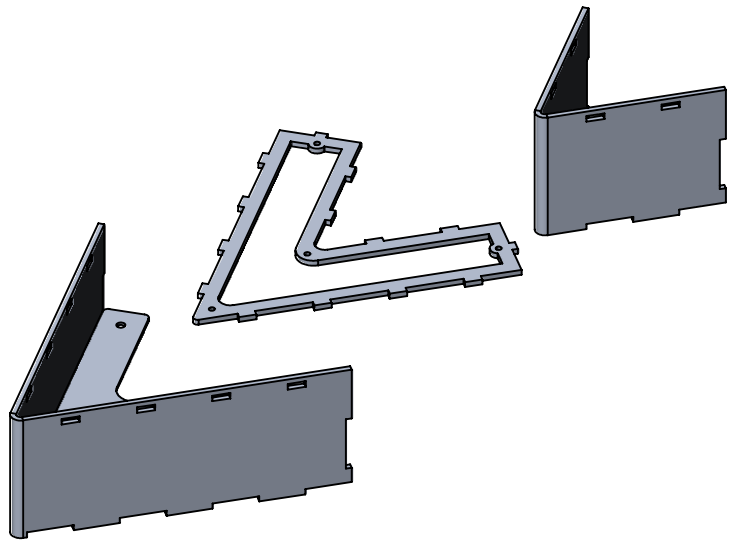

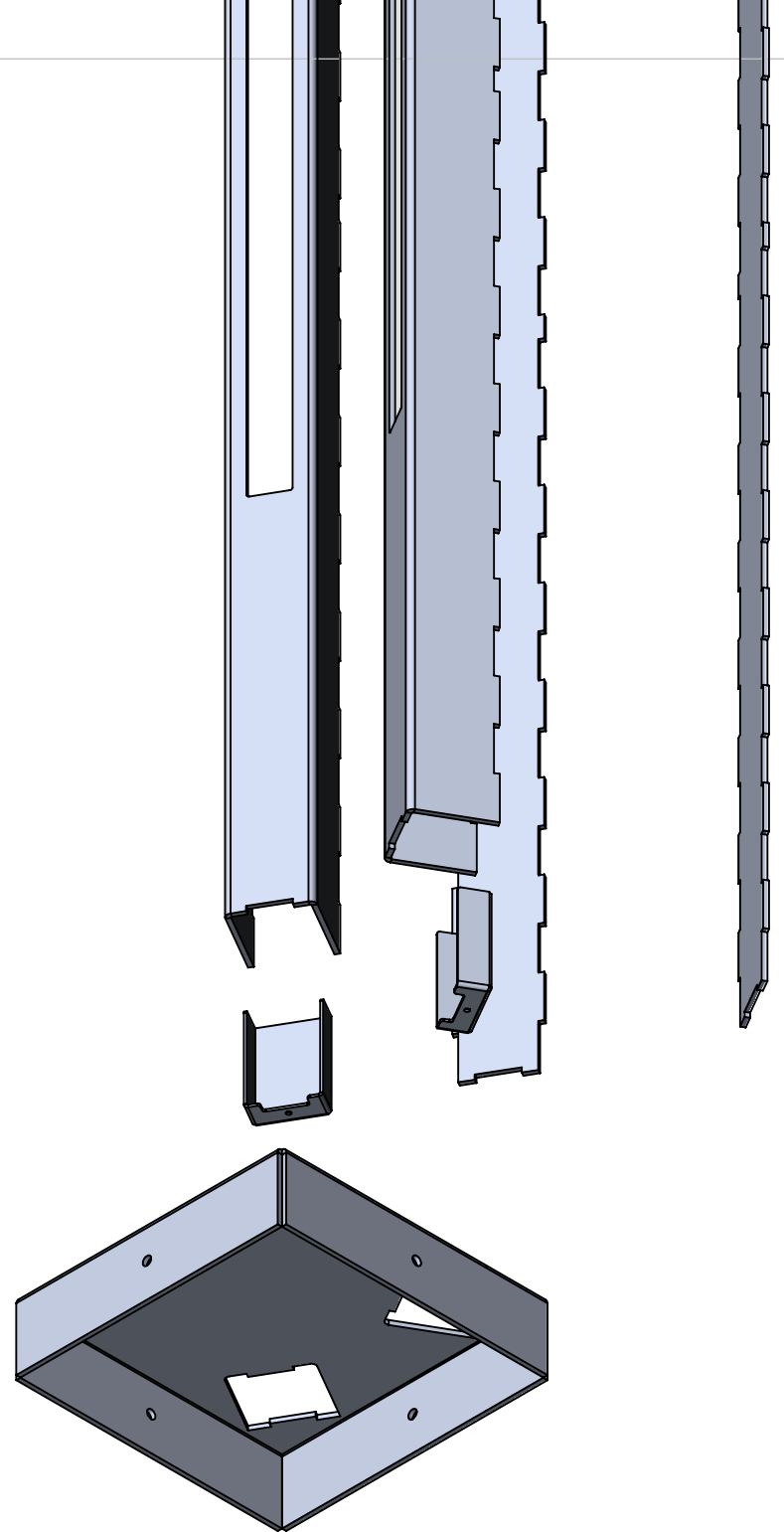
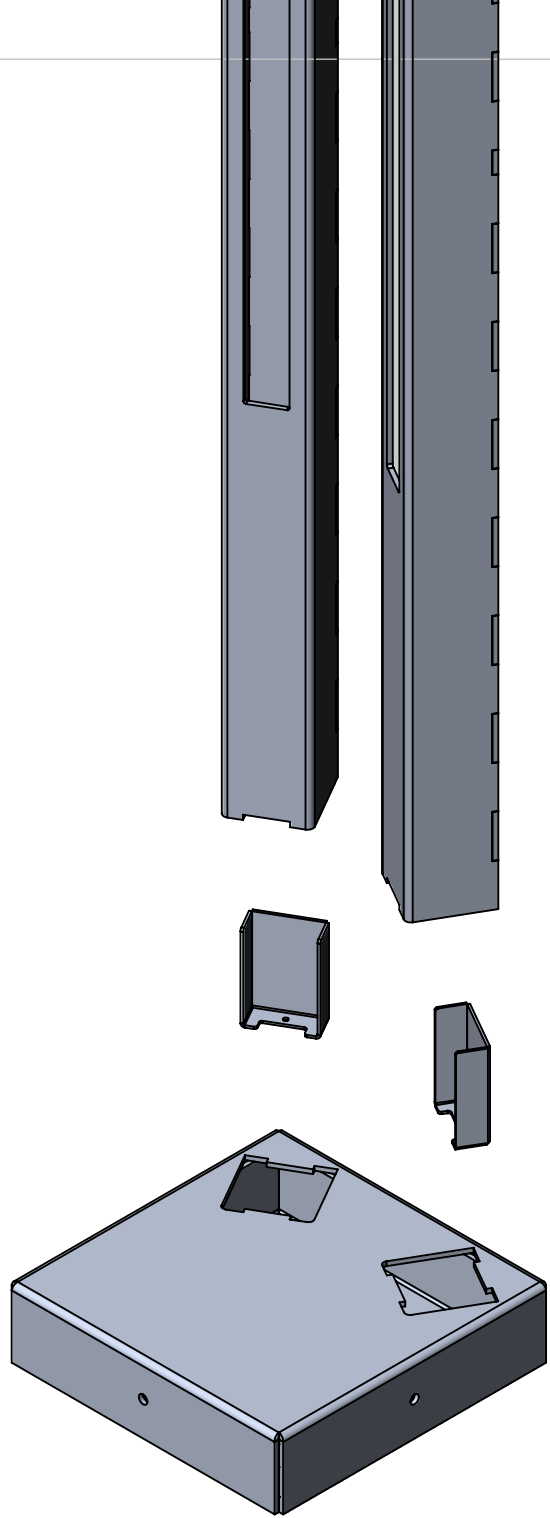

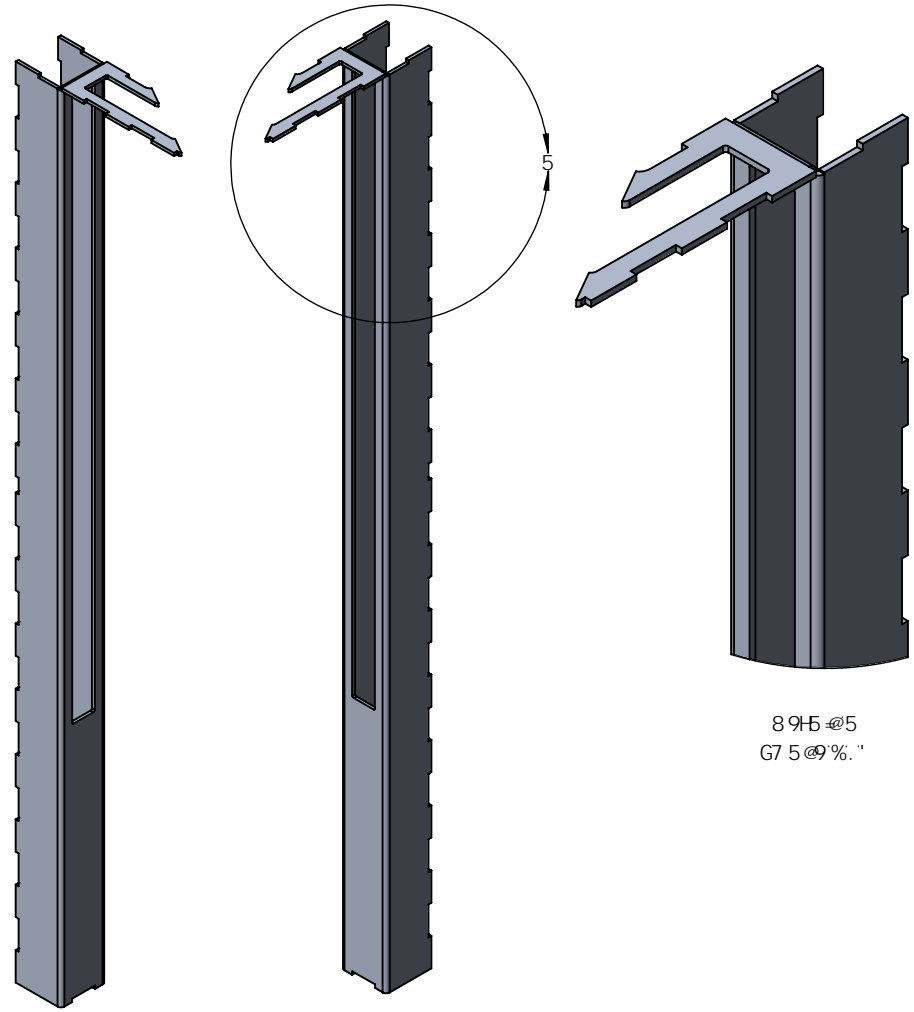
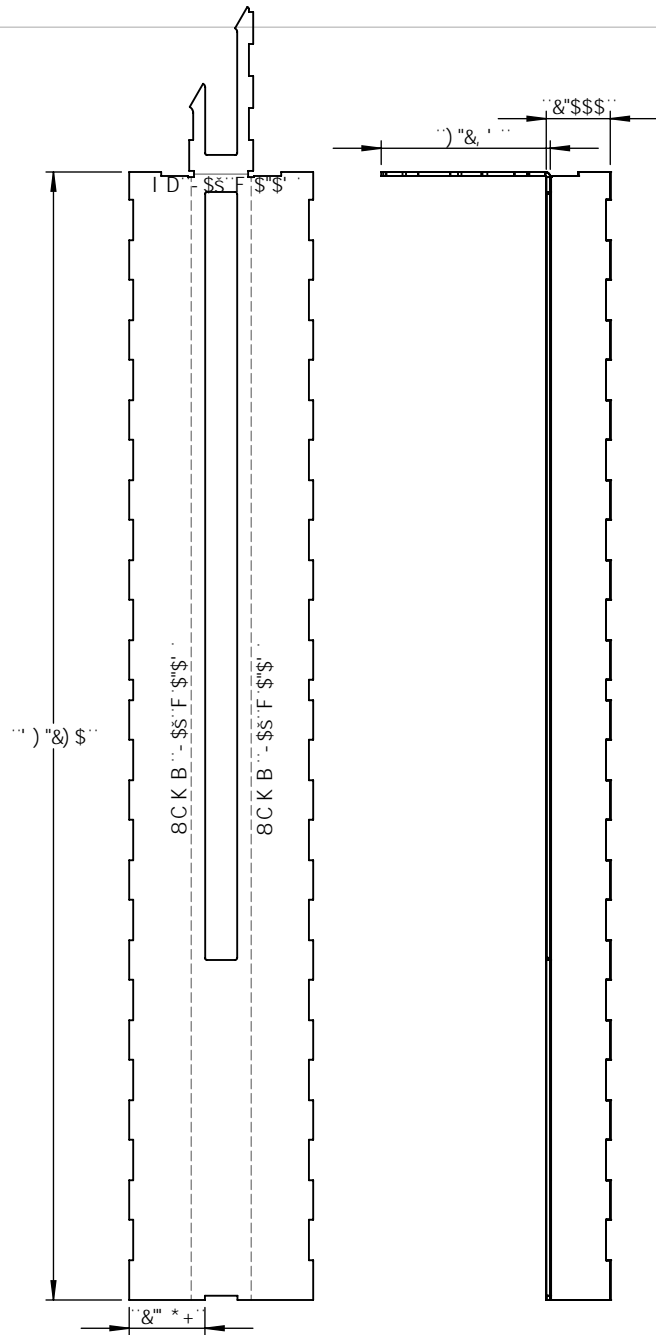

DFC DF 5FM5B87CB: 89BH5@
 H:9 B: CFA 5HC B 7C B15 B98 B H:G
 8F5K B: 4GH:9GC @DFC D9FHC:
 OB99FH7 CA D5BMB5A 9<9F92" 5BM
 F9DFC 81 7HC B B D5FHC F 5G5 K <C @
 K 4:C1 HH:9K F HH9B D9FA 6GC B C:
 O:B99FH7 CA D5BMB5A 9<9F92 G
 DFC <6#98"

B9LH5GGM	I G98 CB
5DD@7 5HC B	

I B @GGCH:9FK 69 GD97 ÷ 98.	B5A 9	85H9
8 A 9BG C BG5F9 B B7 <9G HC @F5B7 9G : F57 HC B5 @± 5B: I @F: A 57 <±69B8 ± HK C D@5 7 9 8 97 A 5 @± H: F99D@5 7 9 8 97 A 5 @±	8F5K B	7 <97 ?98
B H9F DF 9H: 9C A 9F 7 HC @F5B7 B: D9F.	9B: 5DDF"	A: 5DDF"
A 5H9F 5@	E "5"	7 C A A 9BHG
: B <		
8C B CHG7 5 @98F5K B:		

5 @ A B I A '\$"%&) "'D@H9		
H#@.		
J 6C @(\$\$\$\$) \$K !-!K :		
G#9	8K ; "'BC"	F9J
5		
G7 5 @. % *	K 9 ÷ <H'	G<99H) 'C : %\$

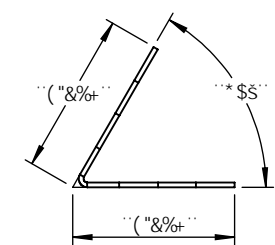
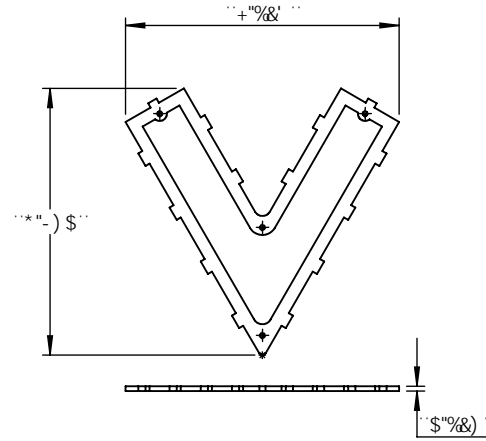
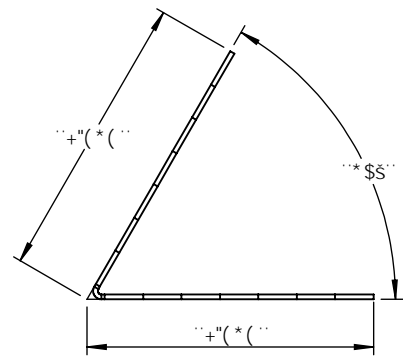
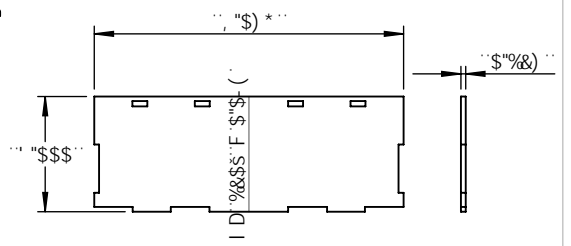
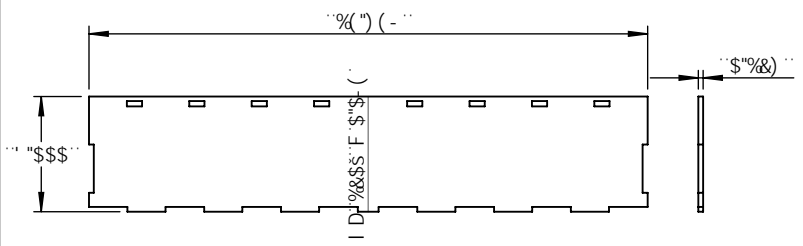
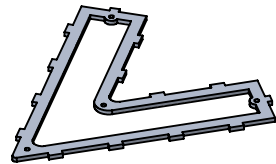
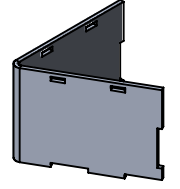
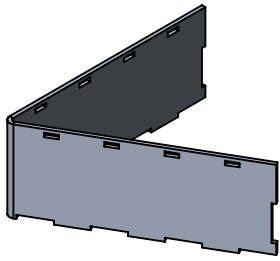

DFC DF-915FM5B87CB: 89B15@
 H:9 B: CFA 5HC B 7 C B15 B98 B H:6
 8F5K B: 6H:9GC @DFC D9FHMC:
 OBG9FH7 CA D5BMB5A 9<9F92" 5BM
 F9DFC 81 7 HC B B D5FHCF 5G5 K <C @
 K H:C1 H:9K F H9B D9FA 6GC B C:
 OBG9FH7 CA D5BMB5A 9<9F92 6
 DFC <6#98*

		I B @GGC H:9FK 69 GD97 ÷ 98.		B5A 9	85H9
		8 A 9BG C BG5F9 B B7 <9G HC @F5B7 9G ; F57 HC B5 @± 5B; I @5F: A 57 <±69B8 ± HK C D@57 9897 A 5@± H:K F99D@57 9897 A 5@±	8F5K B 7 <97 ?98 9B; 5DDF" A: ; 5DDF"		
		B H9F DF 9H: 9C A 9FF 7 HC @F5B7 B: D9F.	E "5" 7 C A A 9BHG		
		A 5H9F 5@			
B9LH5GGM	I G98 C B	: B 6<			
	5DD@7 5HC B	8C B CHG7 5 @98F5K B:			

H#@.			J 6C @(\$fmi" \$K !-!K :		
G#9	8K ; ""BC"				F9J
5					
G7 5 @.%)	K 9 ÷ <H'				G<99H* C : %\$

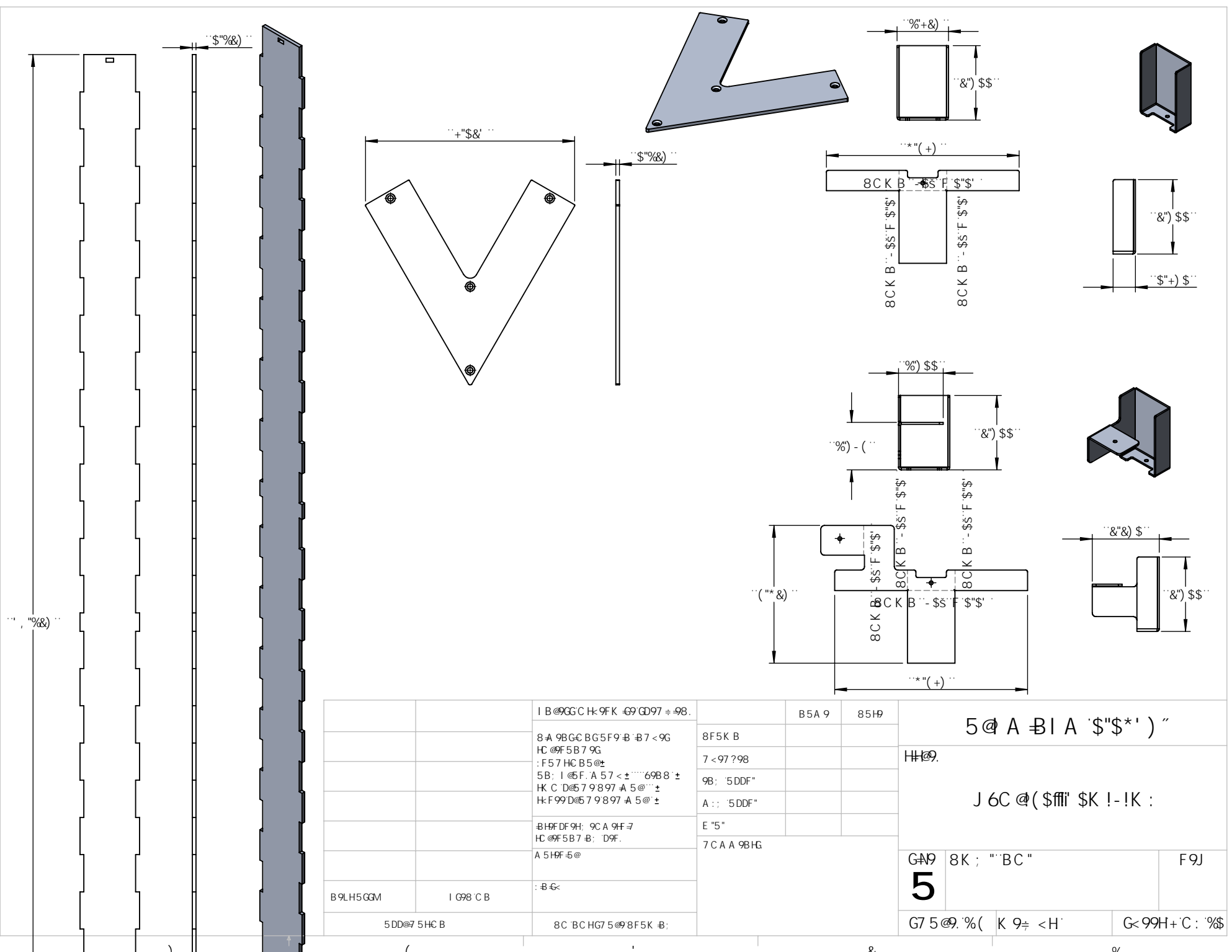

		I B @GGC H: 9FK 69 GD97 ÷ 98.	B5A 9	85H9	5 @ A B I A '\$\$*') "
		8 A 9BG C BG5F9 B B7 < 9G HC @F5B7 9G : F57 HC B5 @± 5B: I @5F: A 57 < ± 69B 8 ± HK C D @57 9897 A 5 @ ± HK F99D @57 9897 A 5 @ ±	8F5K B		H # @.
		B H9F DF 9H: 9C A 9FF 7 HC @F5B7 B: D9F. A 5 H9F 5 @	9B: 5DDF"		J 6C @ (\$ \$\$\$) \$K ! - !K :
B9LH5GGM	I G98 C B	: B <	A: 5DDF"		G A 9 8K ; "'BC"
			E "5"		F9J
			7 C A A 9BHG		
5DD @ 7 5HC B		8C B CHG7 5 @ 8F5K B:			G7 5 @ . % (K 9 ÷ < H'
					G < 99H + C : % \$

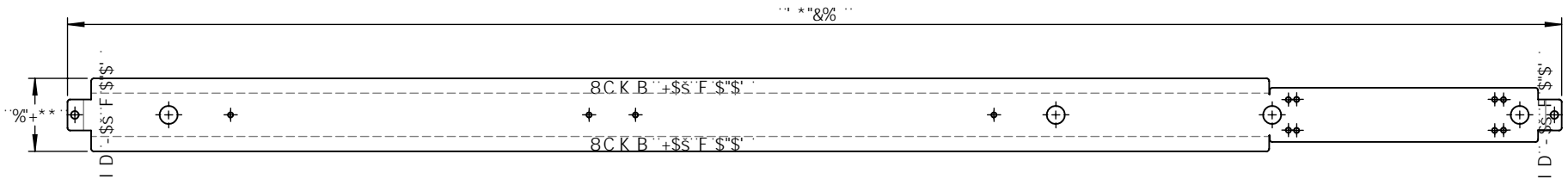
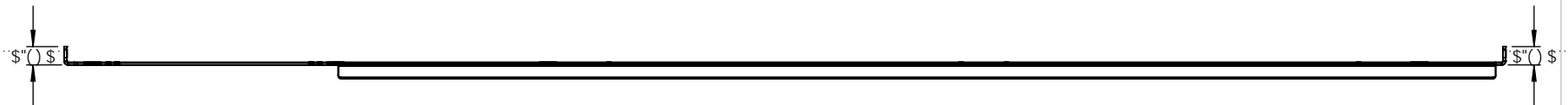
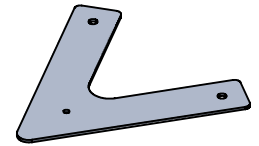
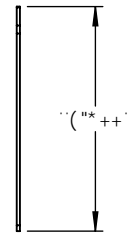
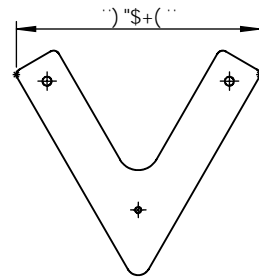
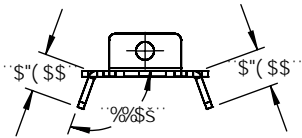
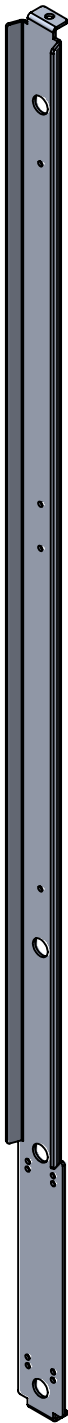

DFC DF-915FM5B87CB: 89BH5@
 H:9 B: CFA 5HC B 7 C B H5 B 98 B H:6
 8F5K B: 6H:9GC @DFC D9FHMC:
 OBG9FH7 CA D5BMB5A 9<9F92" 5BM
 F9DFC 81 7 HC B B D5FHCF 5G5 K <C @
 K H:C I H:K 9K F H9B D9FA 6GC B C:
 OBG9FH7 CA D5BMB5A 9<9F92 6
 DFC <6H98"

		I B @GGCH:9FK 69GD97 ÷ 98. 8A 9BG@BG5F9 B B7 <9G HC @F5B7 9G :F57 HC B5@± 5B: I @5F: A 57 <±69B8 ± HK C D@57 9897 A 5@± H:F99D@57 9897 A 5@±		B5A 9	85H9	5 @ A B I A "\$\$*') "
		BH9FDF9H: 9CA 9FF 7 HC @F5B7 B: D9F. A 5H9F 5@	8F5K B 7 <97 ?98 9B: 5DDF" A: : 5DDF" E "5" 7 C A A 9BHG			H#@.
		:B 6<				J 6C @(\$\$\$\$) \$K !-!K :
B9LH5GGM	I G98 CB					G#9 8K ; ""BC" F9J
5DD@7 5HC B	8C B CHG7 5@98F5K B:					G7 5 @.% (K 9 ÷ <H' G<99H, 'C : %\$

)

(

&

%

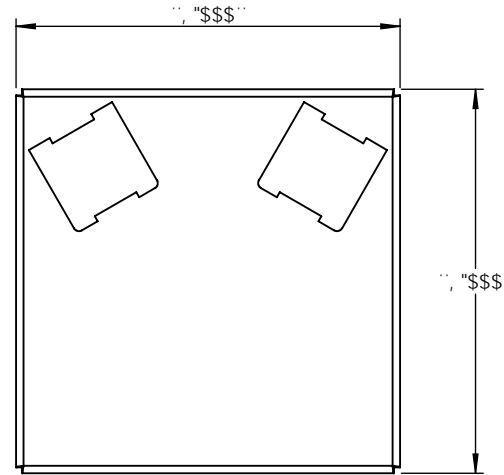
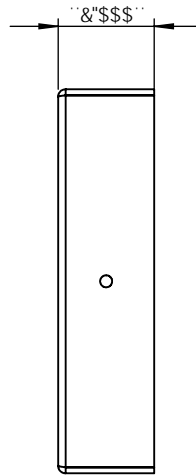
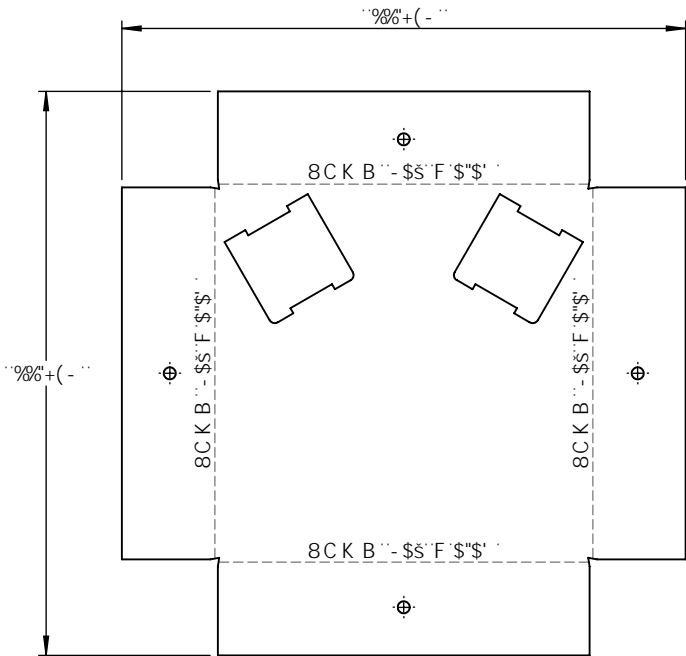
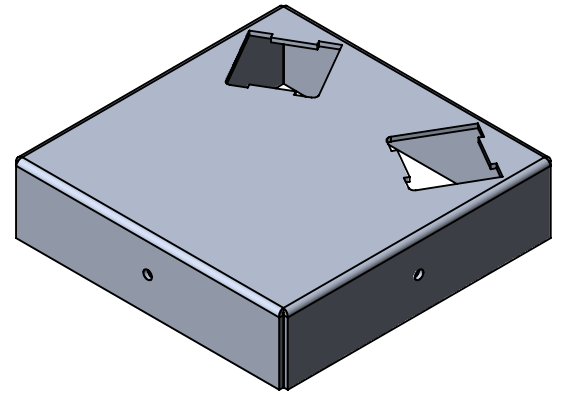

DFC DF 5 FM 5 B 8 7 C B : 8 9 B H 5 @
 H 9 B : C F A 5 H C B 7 C B H 5 B 9 8 B H 6
 8 F 5 K B : 6 H 9 G C @ D F C D 9 F H M C :
 O B G 9 F H 7 C A D 5 B M B 5 A 9 < 9 F 9 2 " 5 B M
 F 9 D F C 8 1 7 H C B B D 5 F H C F 5 G 5 K < C @
 K H C 1 H H 9 K F H 9 B D 9 F A 6 G C B C :
 O B G 9 F H 7 C A D 5 B M B 5 A 9 < 9 F 9 2 6
 D F C < 6 H 9 8 "

		I B @ G G C H : 9 F K 6 9 G D 9 7 ÷ 9 8 .	B 5 A 9	8 5 H 9	5 @ A B I A '\$ "% &) "' D @ 5 H 9	
		8 A 9 B G C B G 5 F 9 B B 7 < 9 G H C @ F 5 B 7 9 G : F 5 7 H C B 5 @ ± 5 B : I @ 5 F : A 5 7 < ± 6 9 B 8 ± H K C D @ 5 7 9 8 9 7 A 5 @ ± ± H : F 9 9 D @ 5 7 9 8 9 7 A 5 @ ±	8 F 5 K B			H # @ .
		B H 9 F D F 9 H : 9 C A 9 F 7 H C @ F 5 B 7 B : D 9 F .	7 < 9 7 ? 9 8		J 6 C @ (\$ m m i ' \$ K ! - ! K :	
		A 5 H 9 F 5 @	9 B : 5 D D F "			
			A : 5 D D F "			
			E " 5 "			
			7 C A A 9 B H G			
	B 9 L H 5 G G M	I G 9 8 C B			G A 9 8 K ; "' BC "	F 9 J
	5 D D @ 7 5 H C B	8 C B C H G 7 5 @ 8 F 5 K B :			5	
						G 7 5 @ . % (K 9 ÷ < H '

)

(

&

%

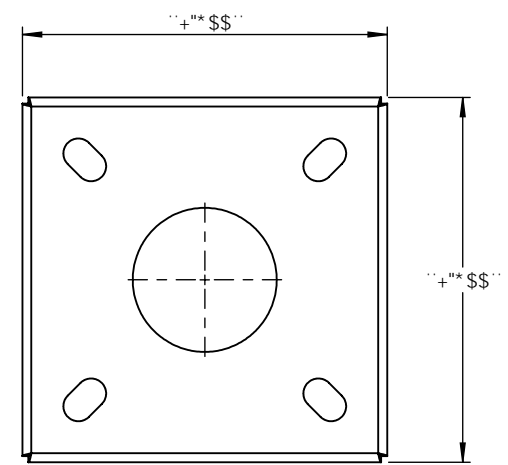
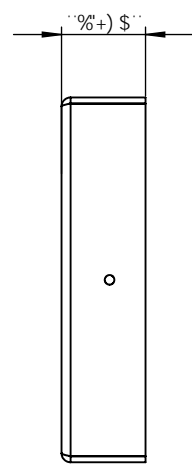
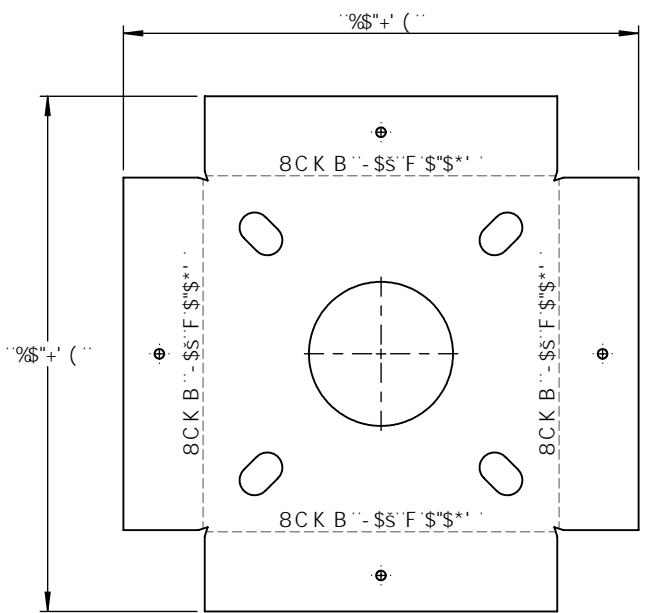
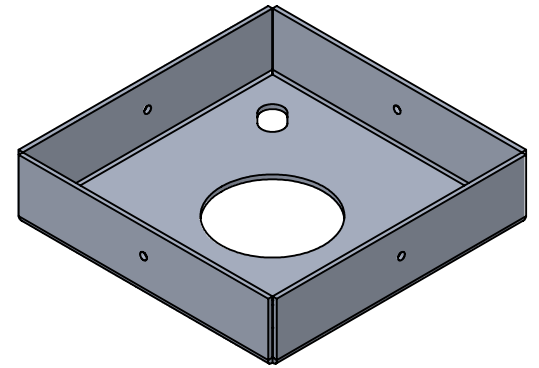

DFC DF 5FM5B87CB: 89B H5@
 H: 9 B: CFA 5HC B 7 C B H5 B 98 B H: 6
 8F5K B: 6H: 9GC @DFC D9F HVC:
 OB G9FH7 CA D5BMB 5A 9 < 9F 92" 5BM
 F9DFC 81 7 HC B B D5FHCF 5G5 K < C @
 K H: C I H: 9K F H9B D9FA 6GC B C:
 OB G9FH7 CA D5BMB 5A 9 < 9F 92 G
 DFC < 6#98"

		I B @GGCH: 9FK 69 GD97 ÷ 98.	B5A 9	85H9
		8 A 9BG C BG5F9 B B7 < 9G HC @F 5B7 9G : F57 HC B5 @± 5B: I @5F: A 57 < ± 69B 8 ± HK C D @5 7 9 8 97 A 5 @ ± H: F99 D @5 7 9 8 97 A 5 @ ±	8F5K B	
		B H9F DF 9H: 9C A 9F 7 HC @F 5B7 B: D9F.	7 < 97 ? 98	
		A 5 H9F 5 @	9B: 5 DDF"	
			A: : 5 DDF"	
			E "5"	
			7 C A A 9BHG	
B9LH5GGM	I G98 C B	: B 6<		
5DD @ 7 5HC B	8C B CHG 7 5 @ 8F5K B:			

5 @ A B I A '\$"%&)" "D @ 5 H 9
 H # @.
 J 6 C @ (\$ f m i " \$ K ! - ! K :
 G A 9 8 K ; " " B C " F 9 J
 5
 G 7 5 @ . % (K 9 ÷ < H ' G < 9 9 H % \$ C : % \$