

#DA "BC"	D5FHBI A 69F	8 9G7 F ðHC B	E HM 7 I H
%	A 58 (&%@A K !K :!(%?!*56' !F8!5@5B7 <CF'D@5H9	: ±H F9 <958	%
&	A 58 (&%@A K !K :!(%?!*56' !F8!5@5B7 <CF'D@5H9	' "5@ A ðB I A 'H 69DC GH	%
'	A 58 (&%@A K !K :!(%?!*56' !F8!5@5B7 <CF'D@5H9	5@ A ðB I A '\$)' '\$\$' D@5H9	%
(A 58 (&%@A K !K :!(%?!*56' !F8!5@5B7 <CF'7CJ 9F	5@ A ðB I A '\$\$*')	&
)	A 58 (&%@A K !K :!(%?!*56' !F8!5@5B7 <CF'7CJ 9F	5@ A ðB I A '\$\$*')	%
*	A 58 (&%@A K !K :!(%?!*56' !F8!5@7CJ 9F'6F57?9H	5@ A ðB I A '\$\$*')	&
+	A 58 (&%@A K !K :!(%?!*56' !F8!5@7CJ 9F' H56	&) ; 5I ; 9	(
,	5B7 <CF'5GG9A 6@M	5B7 <CF'6C @H	(

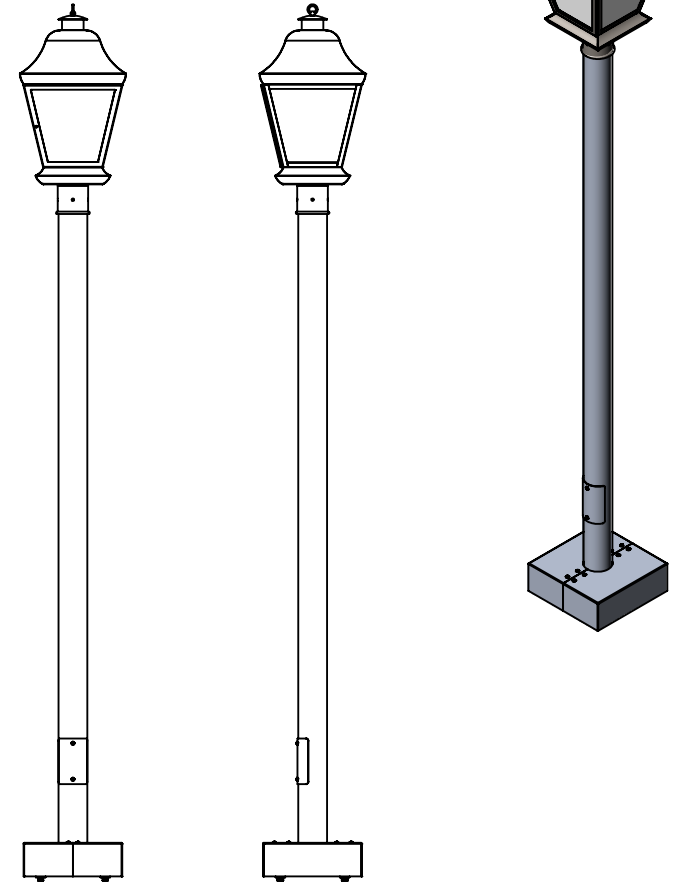
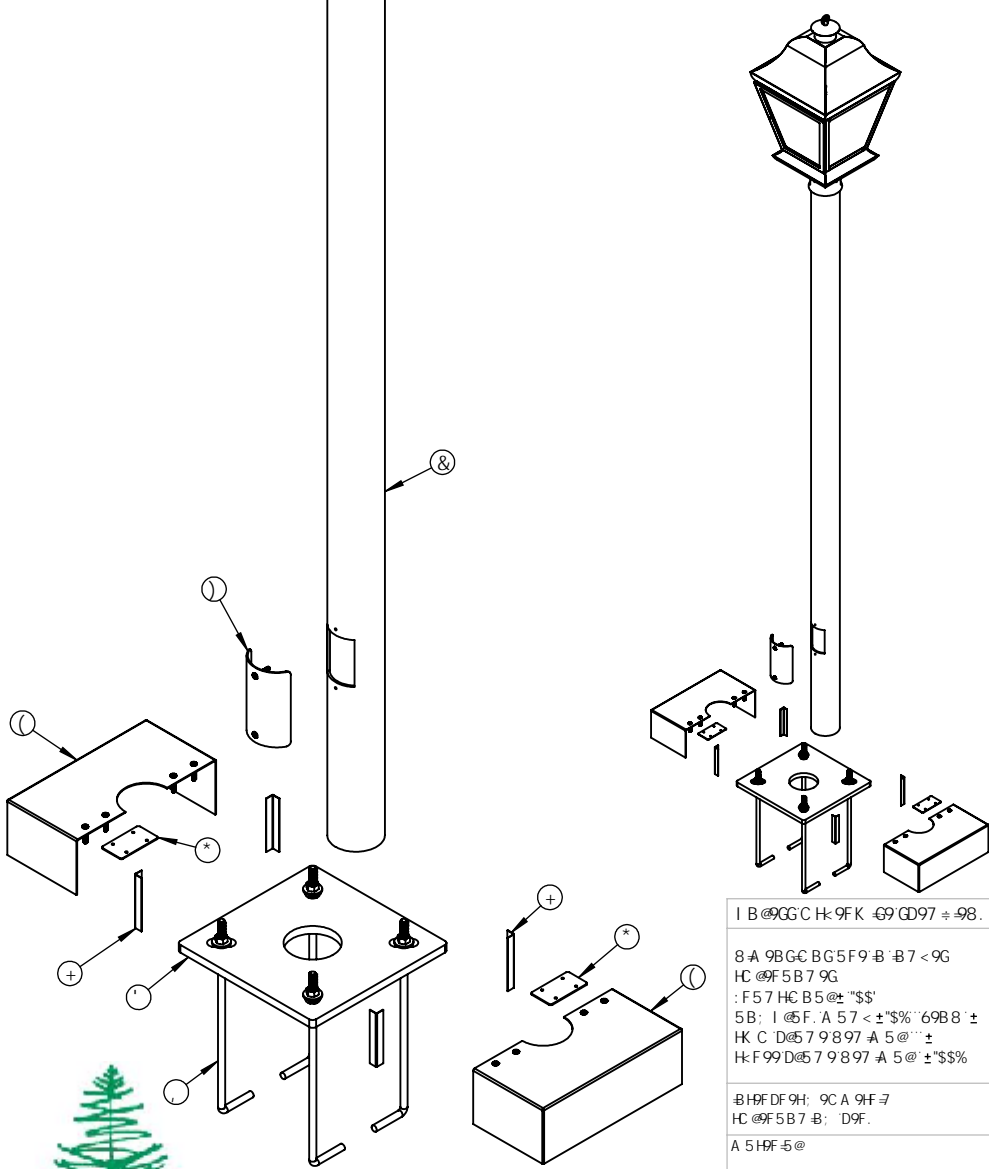

EVERGREEN LIGHTING

5 @69B8 'F58 ð G" '\$' \$"

5DD@7 5HC B

I B @GGC H: 9FK 69 GD97 ð 98.

8 A 9BG@BG5F9 B 'B7 <9G
 HC @F5B7 9G
 : F57 HC B5 @± "\$\$'
 5B: I @5F: A 57 <± "\$\$'" 69B8 ±
 HK C D@57 9897 A 5@' ±
 H: F99D@57 9897 A 5@ ± "\$\$%

BH@DF9H: 9C A 9FF 7
 HC @F5B7 B: 'D9F.
 A 5H@F 5@

: B @<

8C B@HG75 @98F5K B:

B5A 9

85H9

8F5K B

7 <97 ?98

9B: 5DDF"

A: '5DDF"

E "5"

7 C A A 9BHG

H#@.

A 58 (&%@A K !K :!(%?!*56' !F8!5@DC GH

G#9 8K ; "'BC"

F9J

5 H7 ?9H&' * - ,

G7 5 @. %&\$K 9 ð <H'

G<99H%C : '*

)

(

&

%

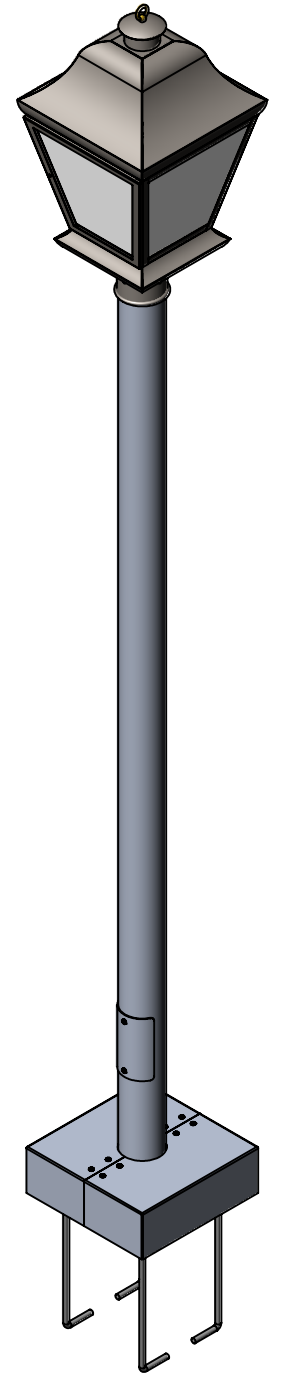
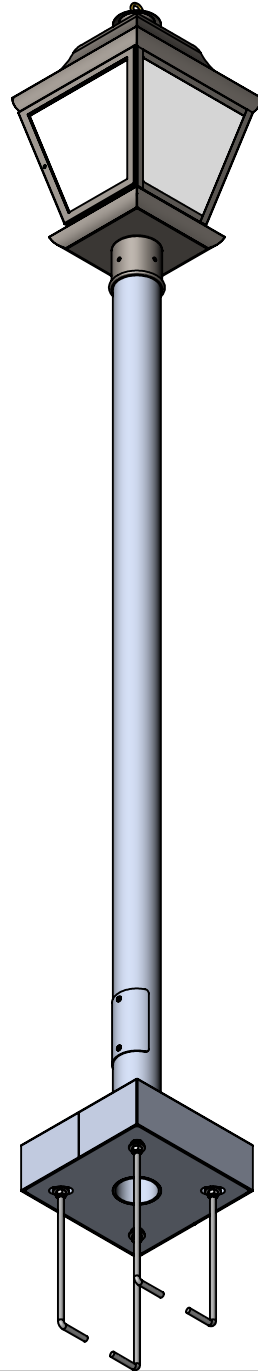
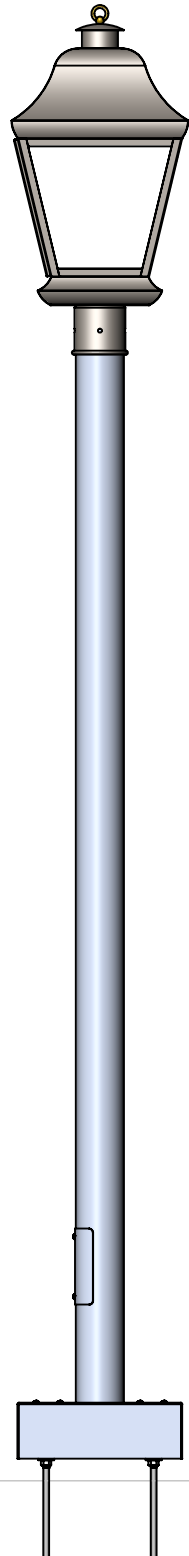
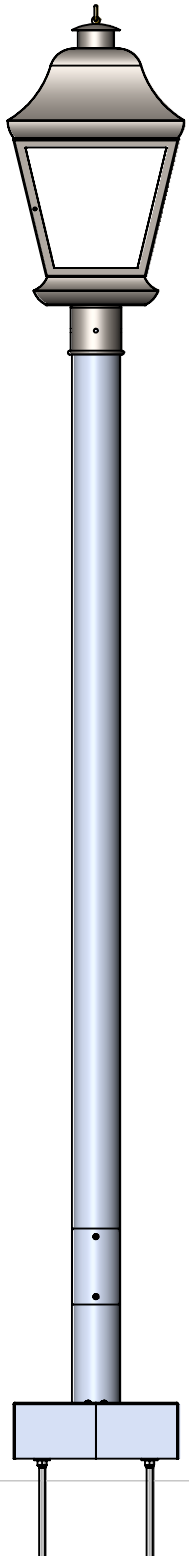

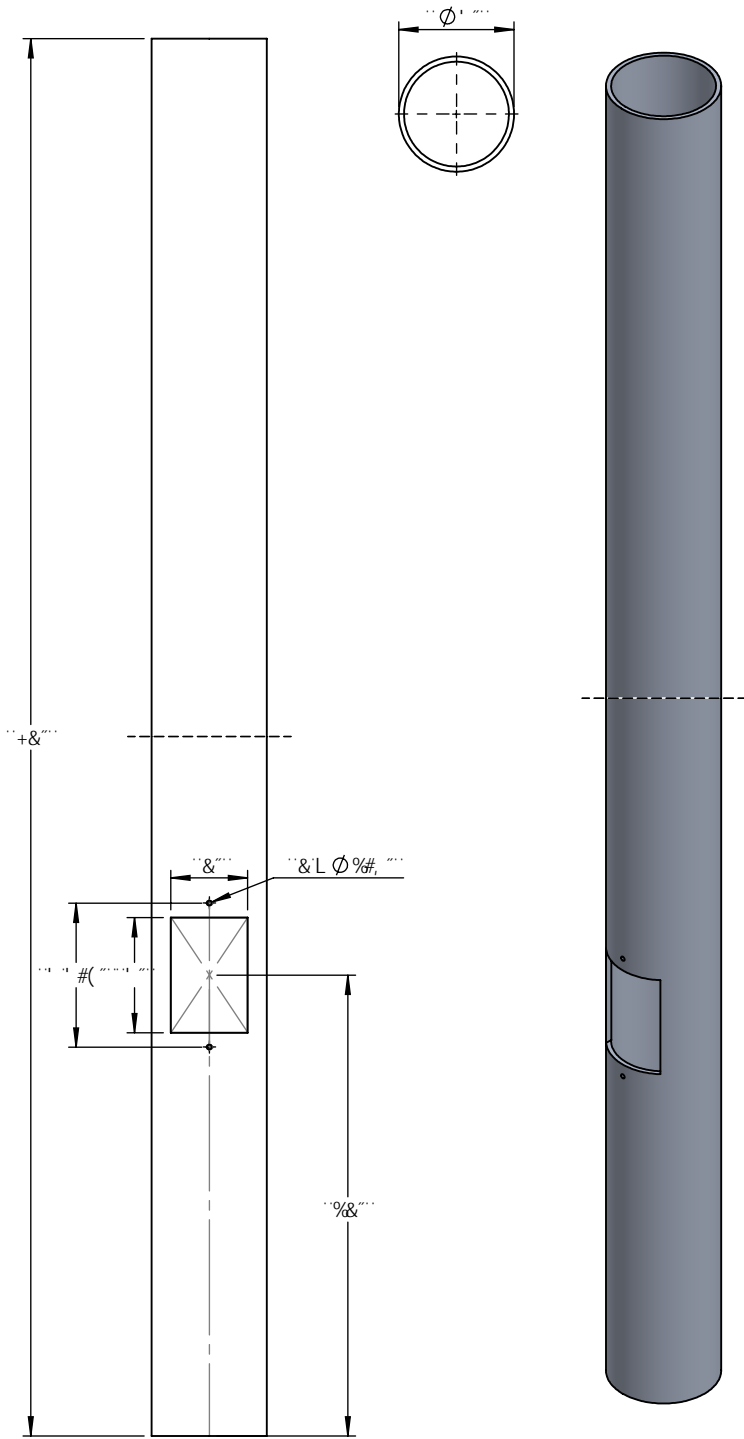

I B @GGC H: 9FK 69 GD97 ÷ 98.		B5A 9	85H9	' "5@ A B I A 'H 69'DC GH
8 A 9BG C BG5F9 B B7 < 9G HC @F5B7 9G : F57 HC B5 @± 5B: I @5F: A 57 < ± 69B8 ± HK C D @57 9897 A 5 @ ± HK F99D @57 9897 A 5 @ ±	8F5K B			H#@.
	7 < 97 ? 98			
	9B: 5DDF"			A 58 (&@A K !K :!(%!*56' !F8!5@DC GH
	A: : 5DDF"			
BH@DF 9H: 9C A 9F 7 HC @F5B7 B: D9F.	E "5"			
A 5H@F 5@	7 C A A 9BHG			
: B @<				G#9 8K ; "'BC " F9J
				5
8C B@HG75 @98F5K B:				G7 5 @. '%& K 9 ÷ < H' G< 99H' 'C: '*

)

(

&

%

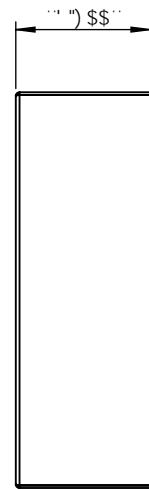
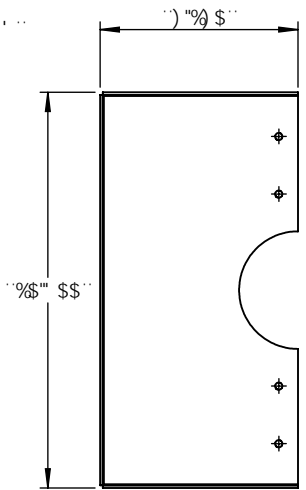
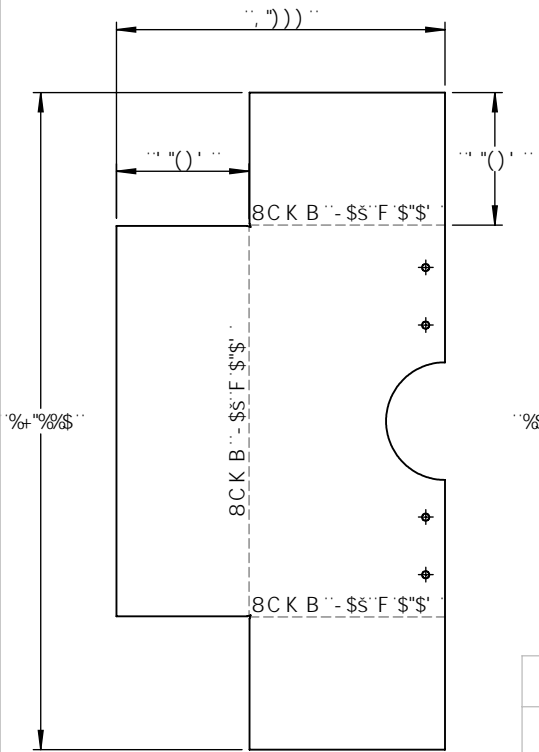
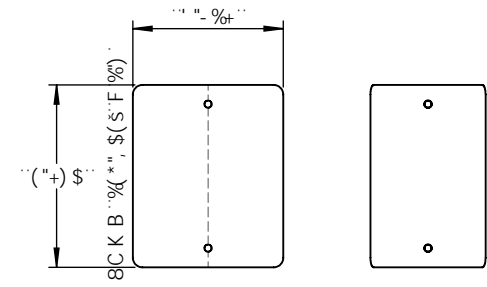
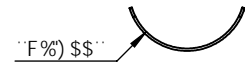
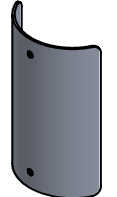
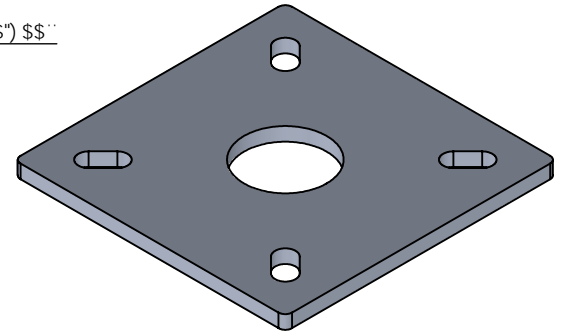
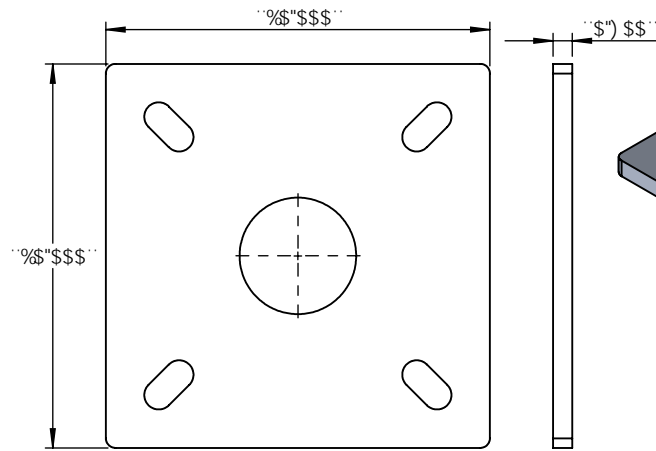
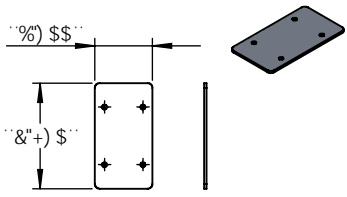

DFC DF 5FM5B87CB: 89BH5@
 H:9 B: CFA 5HC B 7 C B H 5 B 98 B H:6
 8F5K B: 4GH:9GC @DFC D9FHVC:
 OB G9FH7 CA D5BMB5A 9<9F92" 5BM
 F9DFC 81 7 HC B B D5FHCF 5G5 K <C @
 K H:C1 H:9K F H9B D9FA 6GC B C:
 O:BG9FH7 CA D5BMB5A 9<9F92 4
 DFC <6#98"

		I B @GGCH:9FK 69 GD97 ÷ 98.	B5A 9	85H9	5 @ A B I A '\$) \$\$" D@5H9
		8 A 9BG@BG5F9 B B7 <9G HC @F5B7 9G : F57 HC B5 @± 5B: I @5F: A 57 <± 69B8 ± HK C D@57 9897 A 5 @±± H: F99D@57 9897 A 5 @±	8F5K B		H#@.
		B H9FDF9H: 9C A 9FF 7 HC @F5B7 B: D9F.	7 <97 798		
		A 5H9F 5@	9B: 5DDF"		A 58 (&@A K !K :!(%!*56' !F8!5@DC GH
		: B 6<	A: : 5DDF"		
			E "5"		
			7 C A A 9BHG		
B9LH5GGM	I G98 C B				G#9 8K ; "'BC" F9J
5DD@7 5HC B		8C B CHG75 @98F5K B:			G7 5 @.%) K 9 ÷ <H' G<99H('C : *

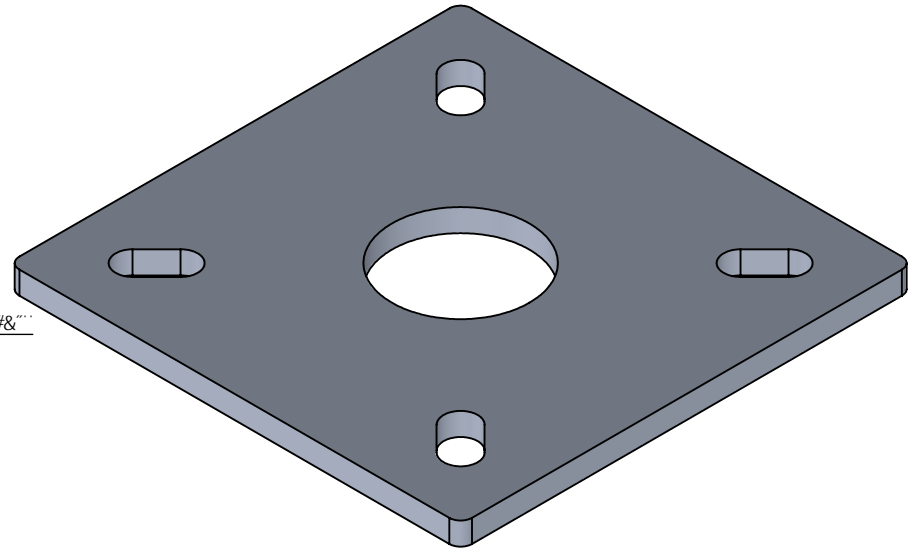
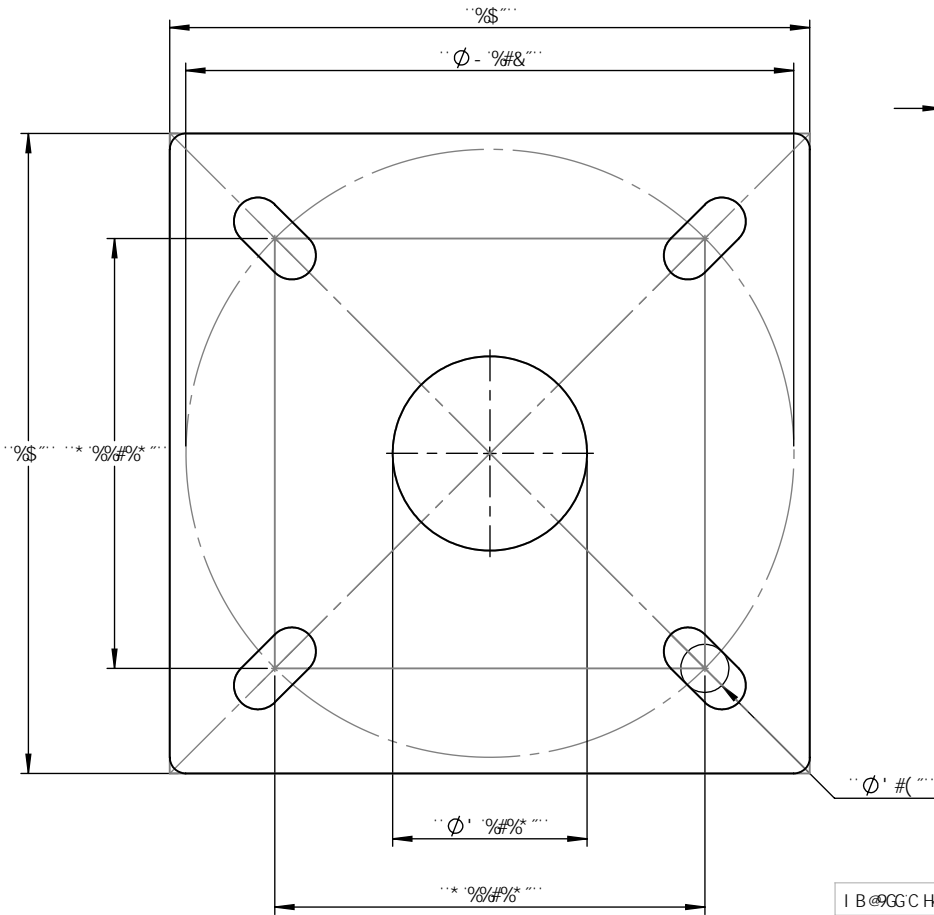

I B @GGC H: 9FK 69 GD97 ÷ 98.	B5A 9	85H9	5 @ A B I A "\$") \$\$ "D @5 H9	
8 A 9BG C BG5F9 B B7 < 9G HC @F 5B7 9G : F57 HC B5 @± 5B: I @5F: A 57 < ± 69B 8 ± HK C D @5 7 9 8 97 A 5 @ ± ± HK F99 D @5 7 9 8 97 A 5 @ ± ±	8F5K B		H#@.	
	7 < 97 ? 98		A 58 (& @ A K ! K : ! (% ! * 5 6 ' ! F 8 ! 5 @ DC GH	
	9B: 5 DDF"			
	A :: 5 DDF"			
	E "5"			
B H F D F 9H: 9C A 9F 7 HC @F 5B7 B: D9F.	7 C A A 9BHG			
A 5 H F 5 @			G A 9	8 K ; " " BC "
: B @ <			5	F 9 J
8 C B CHG 7 5 @ 8 F 5 K B:			G 7 5 @ . %'	K 9 ÷ < H'
				G < 99 H) ' C : '*

DFC DF 5 FM 5 B 8 7 C B: 8 9 B H 5 @
 H: 9 B: C F A 5 H C B 7 C B H 5 B 9 8 B H 6
 8 F 5 K B: 6 H: 9 G C @ D F C D 9 F H M C:
 O B G 9 F H 7 C A D 5 B M B 5 A 9 < 9 F 9 2 " 5 B M
 F 9 D F C 8 I 7 H C B B D 5 F H C F 5 G 5 K < C @
 K H: C I H H: 9 K F H 9 B D 9 F A @ G C B C:
 O B G 9 F H 7 C A D 5 B M B 5 A 9 < 9 F 9 2 G
 D F C < 6 H 9 8 "

B 9 L H 5 G G M I G 9 8 C B
 5 D D @ 7 5 H C B

