

#9A BC "	D5FHBI A 69F	89G7 F-DHC B	E HM	7I H
%	J D%&!GC :!*@A ; !K :!K 9H&+?!657?D@5H9	5@ A -B! A "\$\$*")"	%	
&	J D%&!GC :!*@A ; !K :!K 9H&+?!: #9D@5H9	5@ A -B! A "\$\$*")"	%	
'	J D%&!GC :!*@A ; !K :!K 9H&+?!@98 GD57 9F	5@ A -B! A "\$\$*")"	%	
(	J D%&!GC :!*@A ; !K :!K 9H&+?!: F5A 9D@5H9	5@ A -B! A "\$\$*")"	%	
)	J D%&!GC :!*@A ; !K :!K 9H&+?!9B8 7 5D	5@ A -B! A "\$\$*")"	&	
*	J D%&!GC :!*@A ; !K :!K 9H&+?!57 FM@7	: CFA 98 57 FM@7	%	
+	?H@8!9@!! J !DG )\$( &!J 8-A !@D%	8F= 9F	%	
,	5 HU'@98 SDB%\$\$ (FYj 8	@98	%	

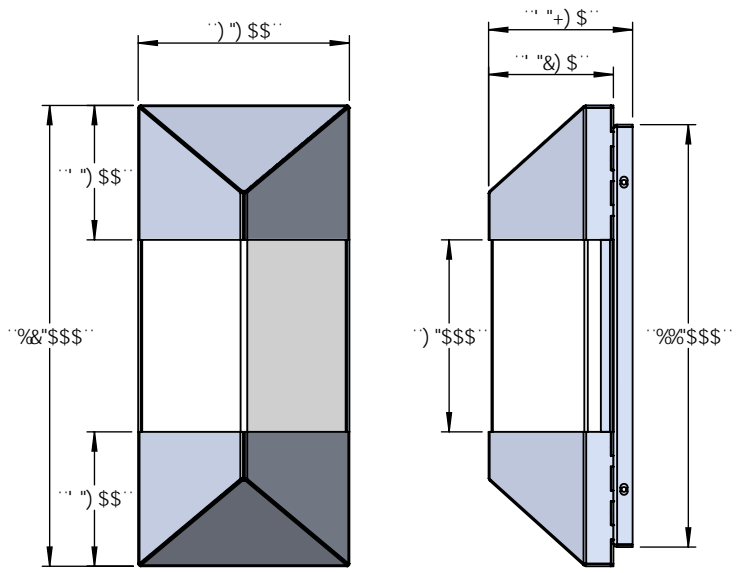

I B @GGC H: 9FK @9 GD97 ÷ 98.	B5A 9	85H9	
8-A 9BG@ BG5F9-B-B7 < 9G HC @F5B7 9G : F57 HC B5 @± "\$\$" 5B: I @5F: A 57 < ± "\$\$"" 69B8 ± HK C D@57 9897-A 5@ ± "\$\$" H: F99D@57 9897-A 5@ ± "\$\$"	8F5K B		H#@.
BH@FDF 9H: 9CA 9FF 7 HC @F5B7 B: D9F. A 5H@F 5@	9B: 5DDF"		J D%&!GC :!*@A ; !K :!K 9H&+?
: B@<	A: 5DDF"		G#9 8K ; ""BC"
5 @@69B8 F58 # G" \$' \$"	E "5"		<b>5</b> H7 ? 9H&' +&
5DD@7 5HC B	7 C A A 9BHG		F9J
8C B@HG7 5@98F5K B:			G7 5 @. %) K 9 ÷ < H'
			G< 99H% C: '-

) ( ' & %

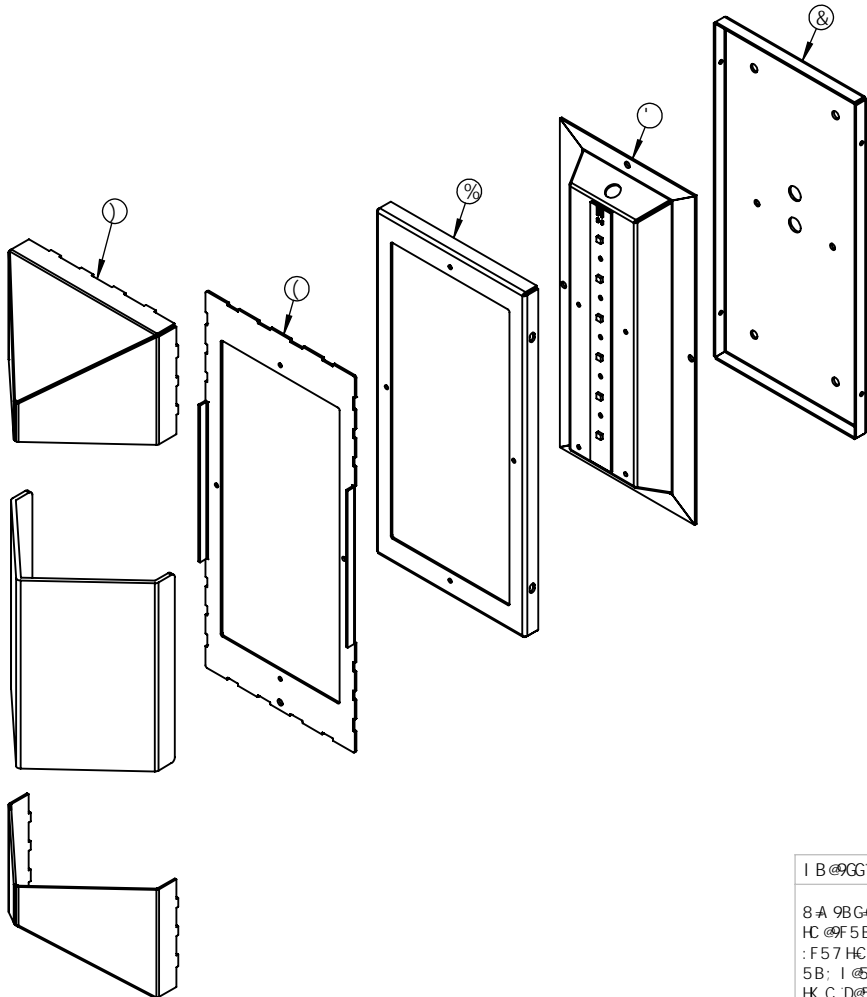
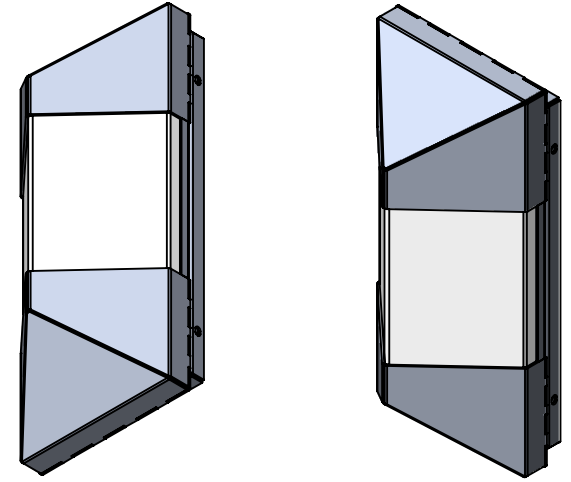
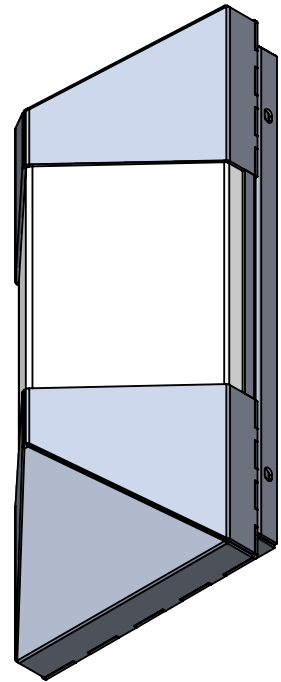
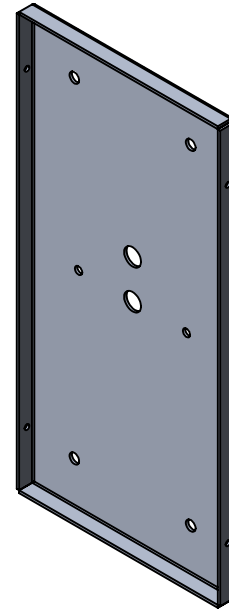
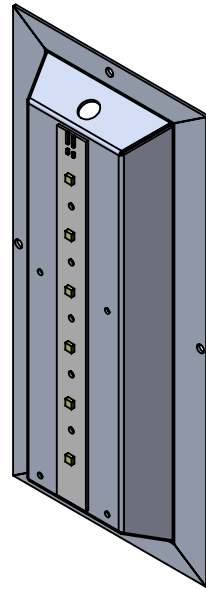
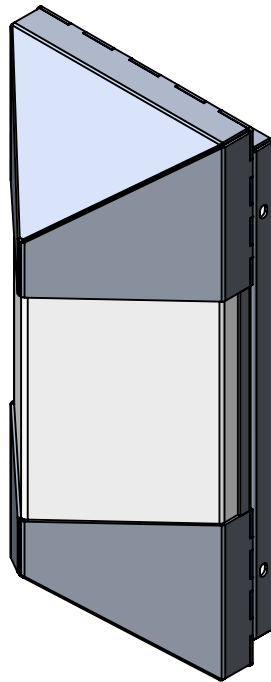
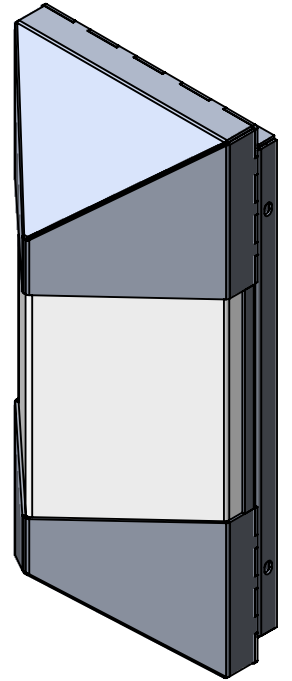
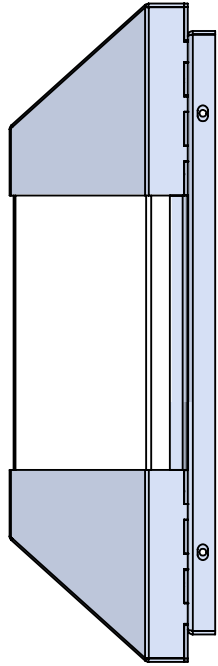
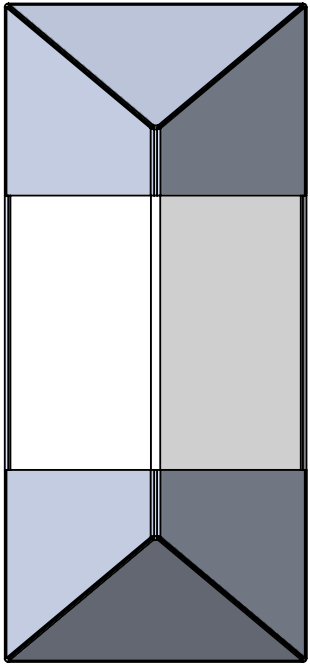

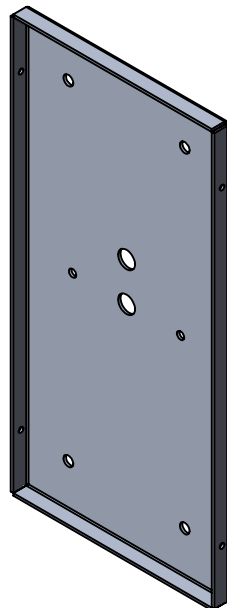
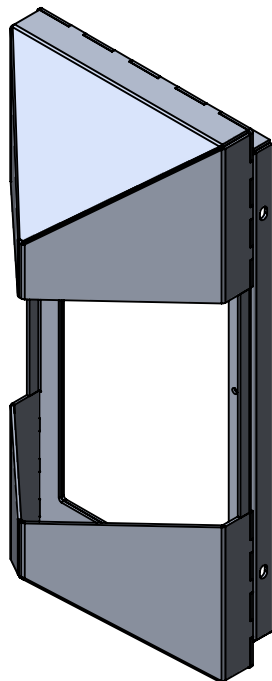
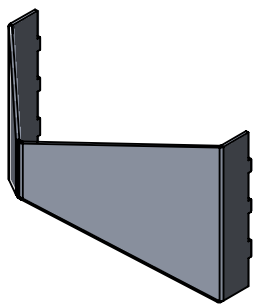
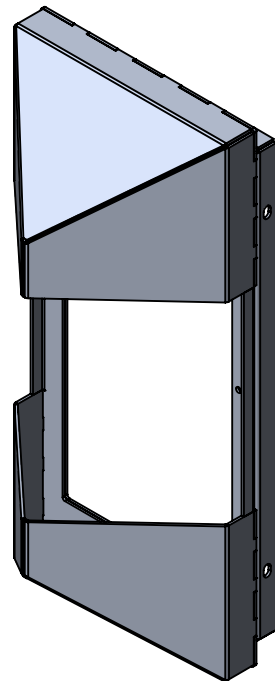
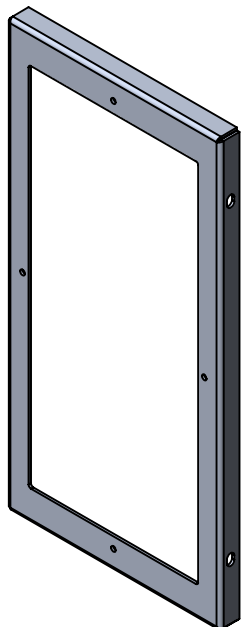
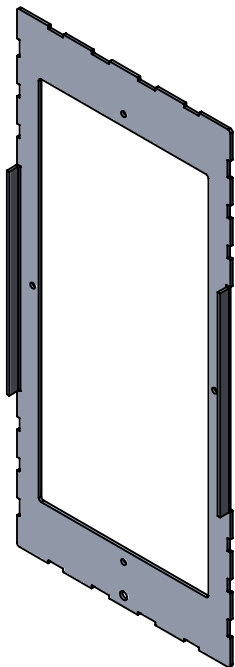
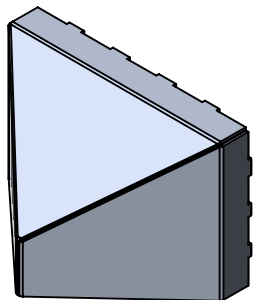

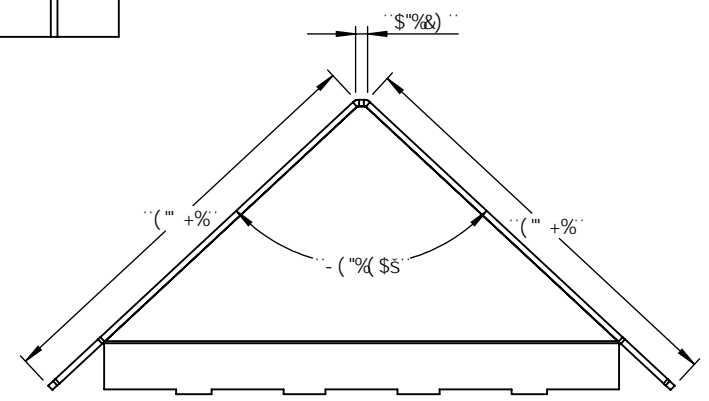
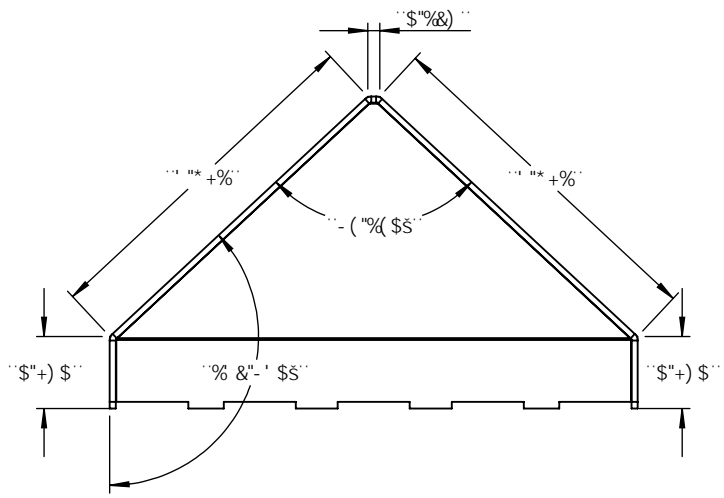
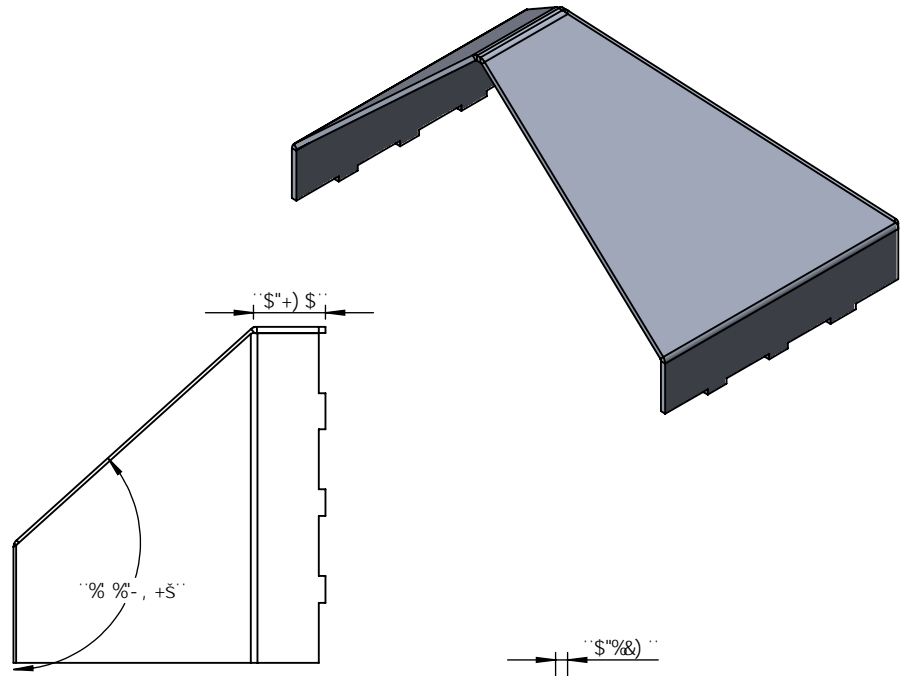
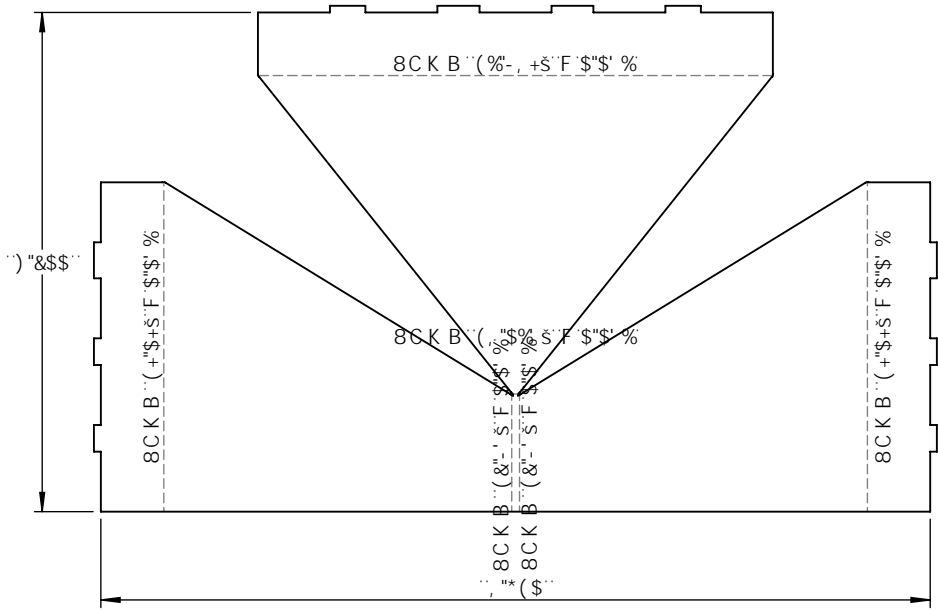

DFC DF 5FM5B87CB: 89BH5@  
 H:9 B: CFA 5HC B 7C B15 B98 B H:6  
 8F5K B: 6H:9GC @DFC D9FHMC:  
 OBG9FH7CA D5BMB5A 9<9F92" 5BM  
 F9DFC 817HC B-B D5FHCF 5G5 K <C @  
 K H:C1 H:9K F H9B D9FA GGC B C:  
 OBG9FH7CA D5BMB5A 9<9F92 G  
 DFC <6H98"

B9LH5GGM	I G98 CB
5DD@7 5HC B	

I B @GGCH:9FK 69GD97 ÷ 98.	B5A 9	85H9
8A 9BG@BG5F9-B B7 <9G HC @F5B7 9G :F57HC B5@± 5B: I @F: A 57 <± .....69B8 ± HK C D@579897 A 5@± H:KF99D@579897 A 5@±	8F5K B	7 <97 ?98
BH9DF9H: 9CA 9F7 HC @F5B7 B: D9F.	9B: 5DDF"	A: : 5DDF"
A 5H9F 5@	E "5"	7 C A A 9BHG
: B <	8C B CHG75 @98F5K B:	

5@A BIA "\$*\$' ) "		
H#@.		
J D%&GC :!*@A ; !K :!K 9H&+?		
G#9	8K ; ""BC"	F9J
<b>5</b>		
G7 5 @. %&	K 9 ÷ <H'	G<99H('C : -

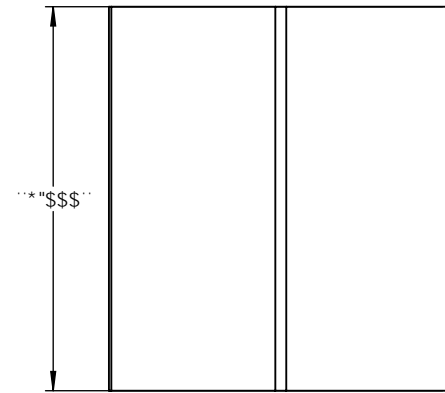
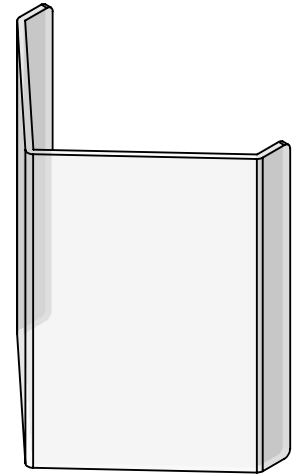
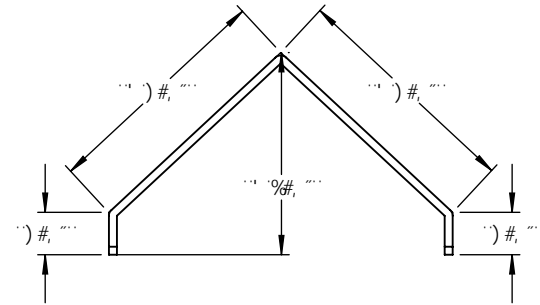
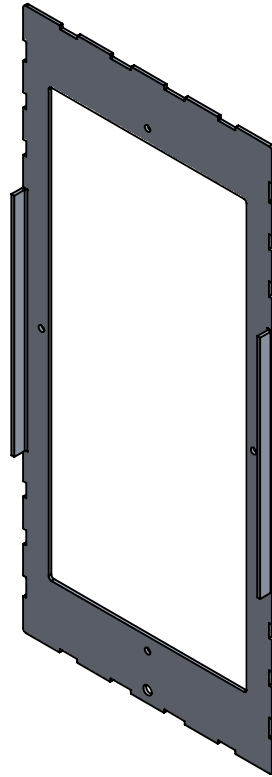
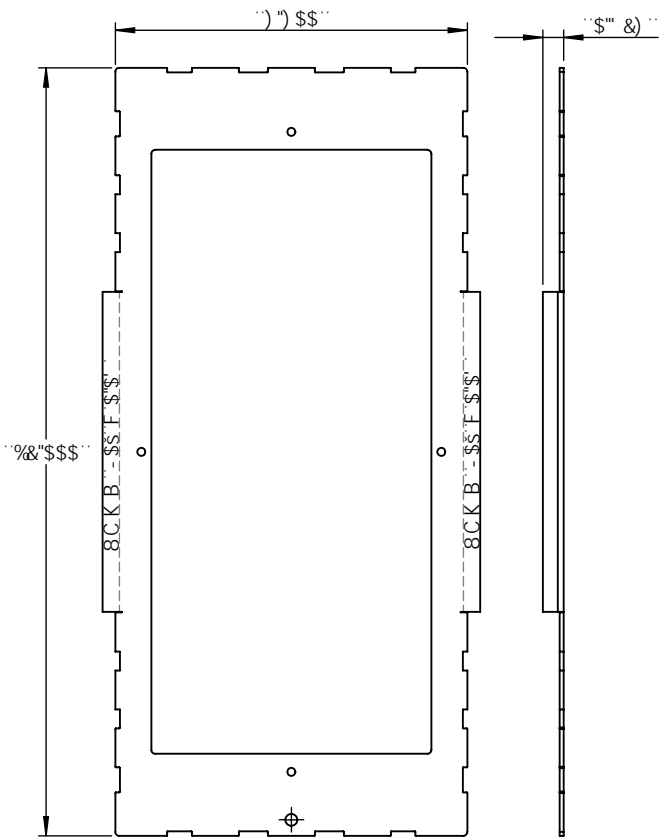

DFC DF-915FM5B87CB: 89BH5@  
 H:9 B: CFA 5HC B 7 C B H5 B 98 B H:6  
 8F5K B: 6H:9GC @DFC D9F HVC:  
 OBG9FH7 CA D5BMB5A 9<9F92" 5BM  
 F9DFC 81 7 HC B B D5FHCF 5G5 K <C @  
 K H:C1 H:K 9K F H9B D9FA 6GC B C:  
 OBG9FH7 CA D5BMB5A 9<9F92 6  
 DFC <6H98\*

B9LH5GGM I G98 CB  
 5DD@7 5HC B

I B @GGCH:9FK 69GD97 ÷ 98.  
 8A 9BGCBG5F9 B B7 <9G  
 HC @F5B7 9G  
 :F57 HC B5@±  
 5B: I @F: A 57 <±.....69B8 ±  
 HK C D@57 9897 A 5@±  
 H:F99D@57 9897 A 5@±  
 BHFDF9H: 9CA 9FF 7  
 HC @F5B7 B: D9F.  
 A 5HF 5@  
 :B<  
 8C BCHG75@98F5K B:

B5A 9 85H9  
 8F5K B  
 7 <97 98  
 9B: 5DDF"  
 A: 5DDF"  
 E "5"  
 7 C A A 9BHG

5@ A BIA '\$\$\*' ) "  
 H#@.  
 J D%&!GC :!\*@A ; !K :!K 9H&+?  
 GA9 8K ; ""BC" F9J  
 5  
 G7 5 @. %' K 9 ÷ <H' G<99H) 'C : '-

K 98'5@5FCI B8

I G98) ; 5I ; 95@ A -BI A 'H56'  
HC 7 @ G9'5B8'K 98' G95A G

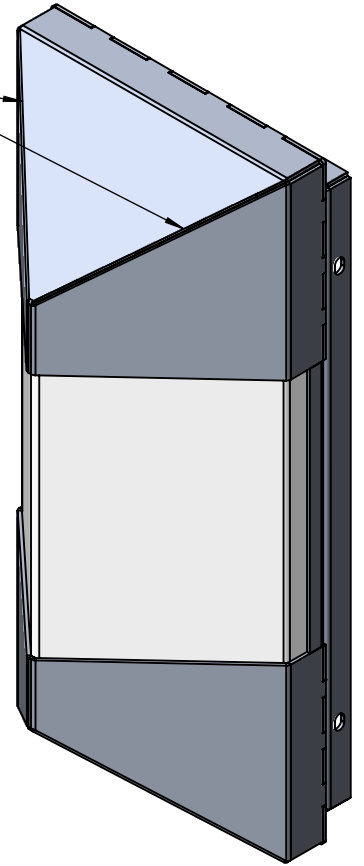
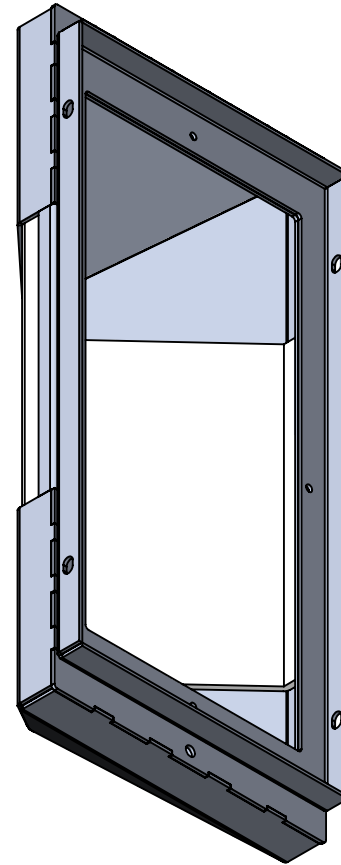
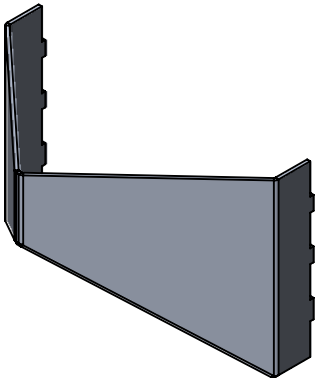
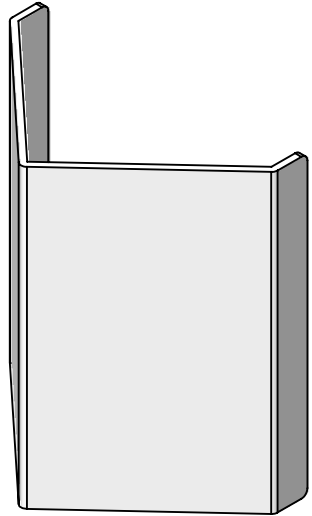
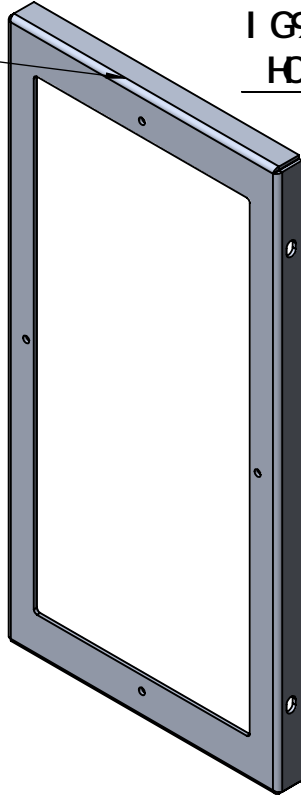
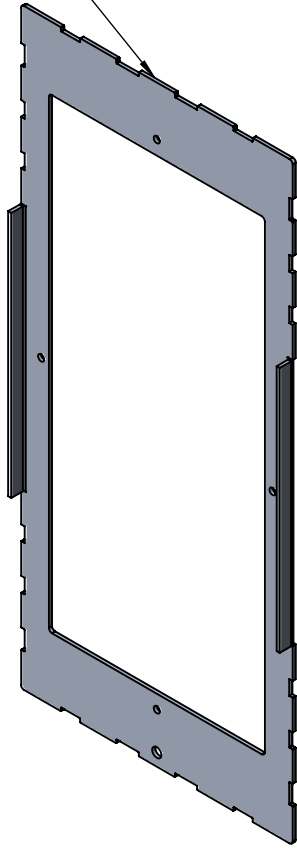
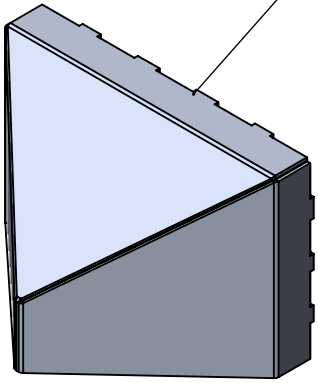

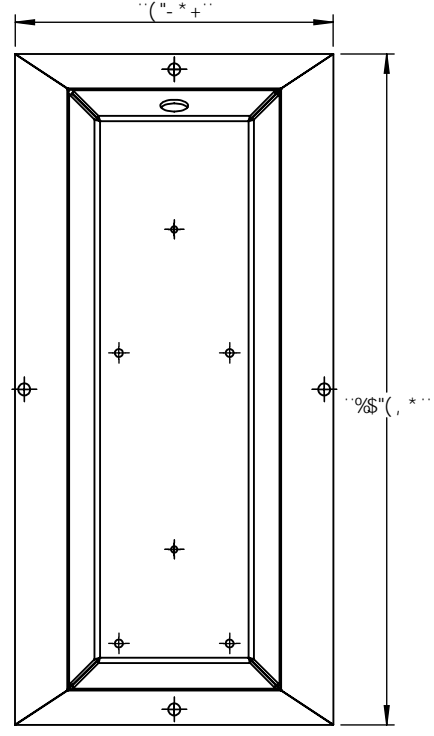
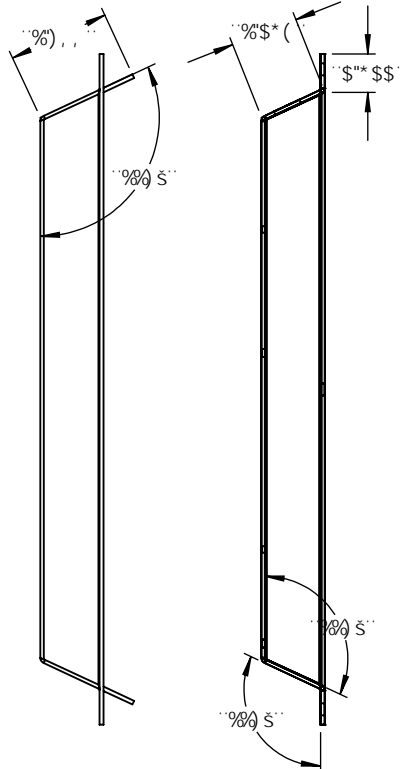
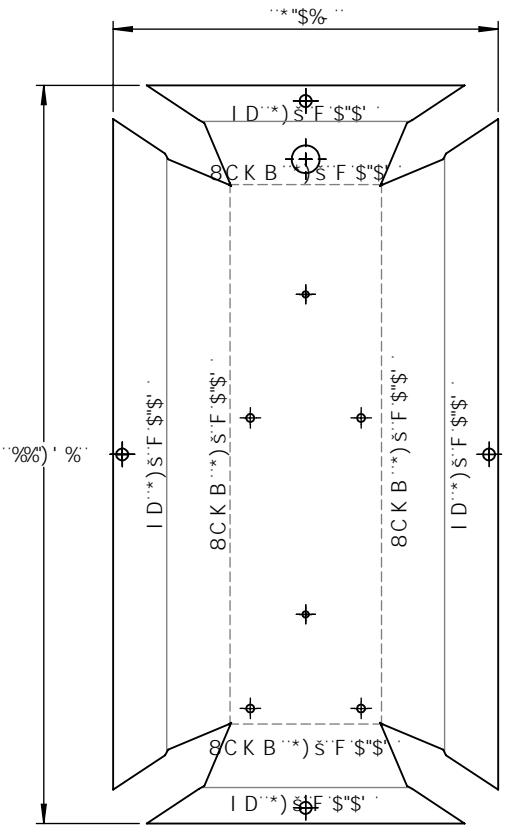
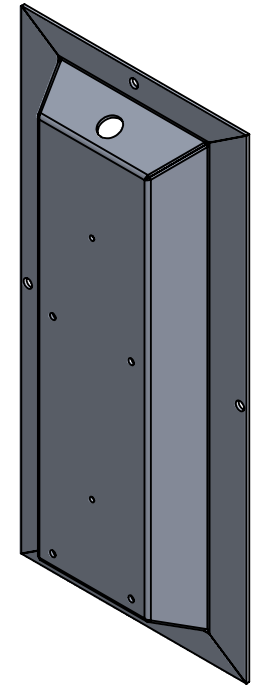
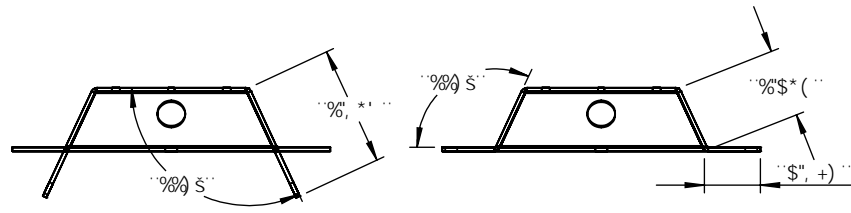

DFC DF 5 FM 5 B 8 7 C B : 8 9 B H 5 @  
 H: 9 B: CFA 5HC B 7 C B H 5 B 98 B H: 6  
 8F5K B: 6H: 9GC @DFC D9F HVC:  
 OB 9FH7 CA D5BMB 5A 9 < 9F 92 " 5BM  
 F9DFC 81 7 HC B B D5FHCF 5G5 K < C @  
 K H: C I H: 9 K F H 9 B D 9FA 6GC B C:  
 O: B 9FH7 CA D5BMB 5A 9 < 9F 92 6  
 DFC < 6 H 98 "

B 9 L H 5 G G M I G 9 8 C B  
 5 D D @ 7 5 H C B

I B @ G G C H: 9 F K 6 9 G D 9 7 ÷ 9 8.  
 8 A 9 B G C B G 5 F 9 B B 7 < 9 G  
 H C @ F 5 B 7 9 G  
 : F 5 7 H C B 5 @ ±  
 5 B: I @ F: A 5 7 < ± ..... 6 9 B 8 ±  
 H K C D @ 5 7 9 8 9 7 A 5 @ ± ±  
 H: F 9 9 D @ 5 7 9 8 9 7 A 5 @ ± ±

B H F D F 9 H: 9 C A 9 F 7  
 H C @ F 5 B 7 B: D 9 F.  
 A 5 H F 5 @  
 : B < 6

8 C B C H G 7 5 @ 8 F 5 K B:

	B 5 A 9	8 5 H 9
8 F 5 K B		
7 < 9 7 9 8		
9 B: 5 D D F "		
A: : 5 D D F "		
E " 5 "		
7 C A A 9 B H G		

5 @ A B I A '\$\$\*' ) "

H @ .

J D % & ! G C : ! \* @ A ; ! K : ! K 9 H & + ?

G A 9	8 K ; " " B C "	F 9 J
<b>5</b>		
G 7 5 @ . %'	K 9 ÷ < H'	G < 9 9 H + C : '-

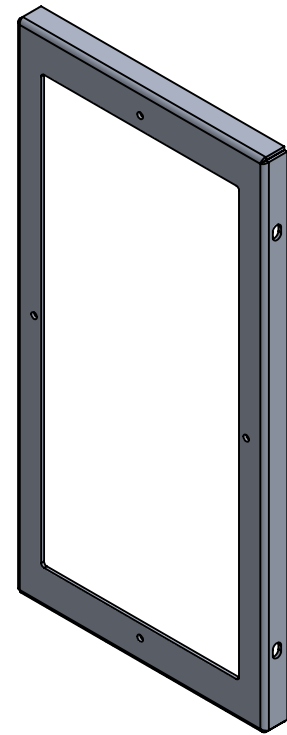
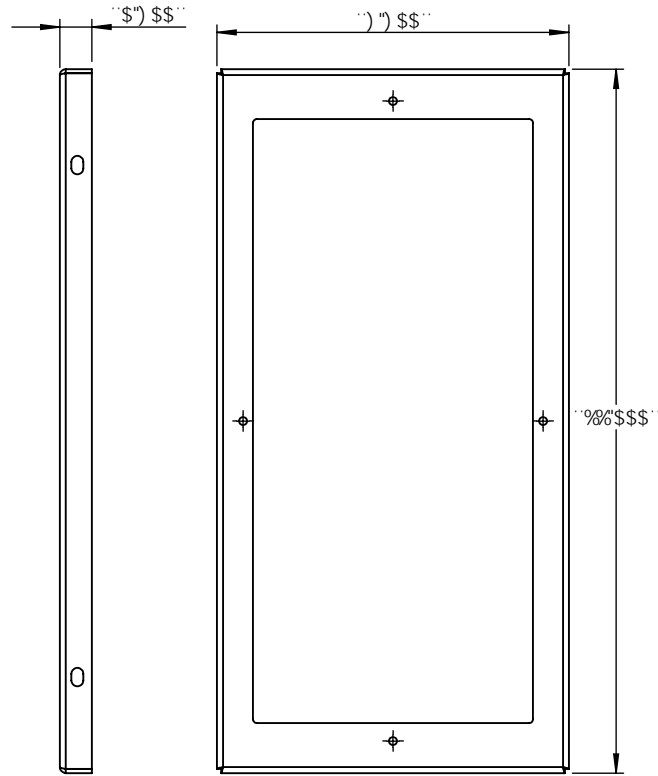
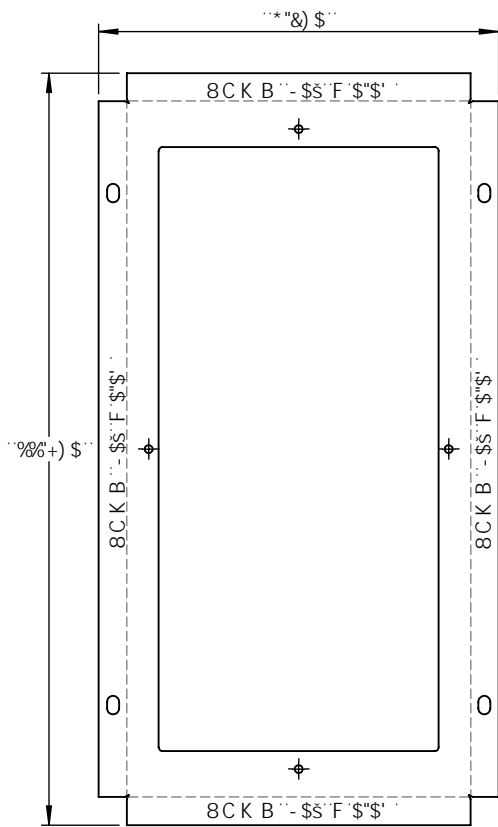

DFC DF 5FM5B87CB: 89BH5@  
 H:9 B: CFA 5HC B 7 C BI5 B98 B H:6  
 8F5K B: 6H:9GC @DFC D9F HVC:  
 OBG9FH7 CA D5BMB5A 9<9F92" 5BM  
 F9DFC 81 7 HC B B D5FHCF 5G5 K <C @  
 K H:C I H:9K F H9B D9FA 6GC B C:  
 OBG9FH7 CA D5BMB5A 9<9F92 6  
 DFC <6H98"

B9LH5GGM

I G98 CB

5DD@7 5HC B

I B @GGC H:9FK 69 GD97 ÷ 98.

8 A 9BG C BG5F9 B B7 <9G  
 HC @F 5B7 9G  
 : F57 HC B5 @±  
 5B: I @F: A 57 <± .....69B 8 ±  
 HK C D@5 7 9897 A 5 @±  
 H:KF99D@5 7 9897 A 5 @±

BH9FDF9H: 9CA 9FF 7  
 HC @F 5B7 B: D9F.

A 5H9F 5@

: B 6<

8C BCHG75 @98F5K B:

B5A 9

85H9

8F5K B

7 <97 ?98

9B: 5DDF"

A: 5DDF"

E "5"

7 C A A 9BHG

5 @ A B I A '\$\$\*' ) "

H#@.

J D%&!GC :!\*@A ; !K :!K 9H&+?

G#9  
5

8K ; "'BC"

F9J

G7 5 @. %'

K 9 ÷ <H'

G<99H, 'C: '-

)

(

&

%



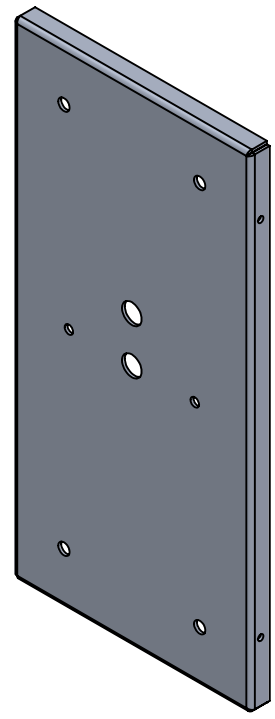
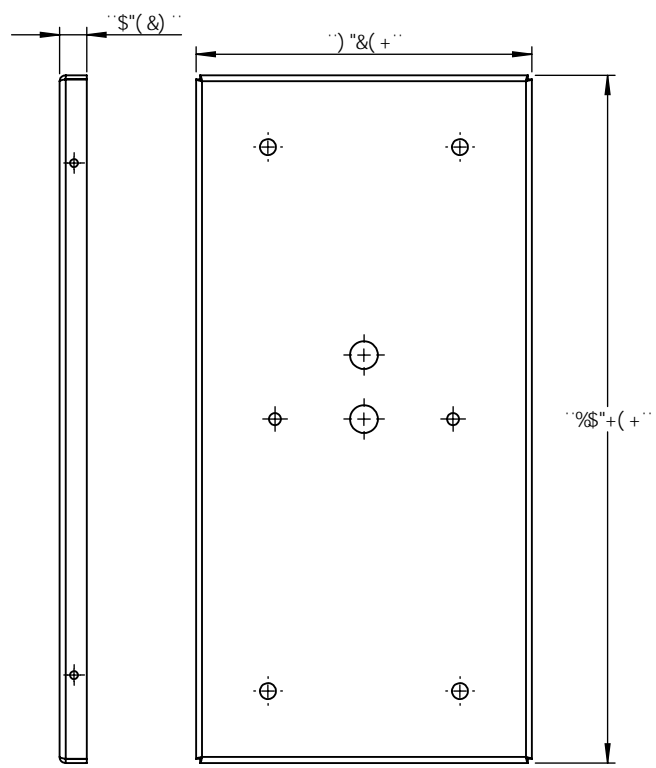
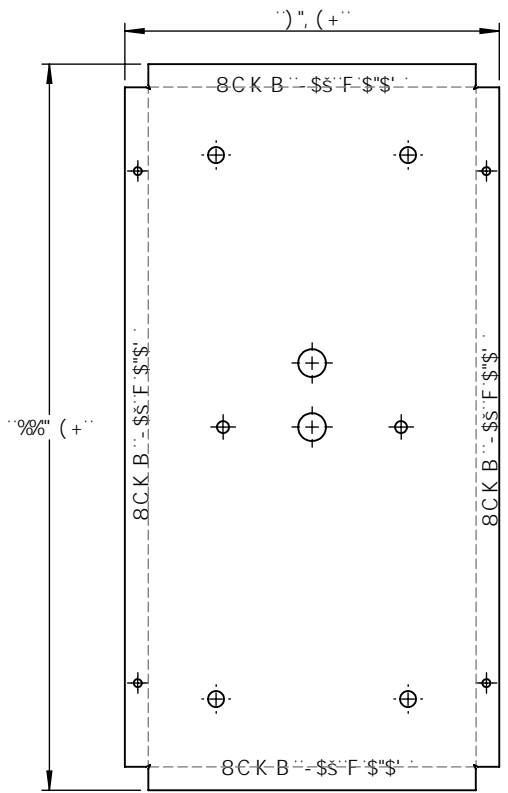

DFC DF 5 FM 5 B 8 7 C B : 8 9 B H 5 @  
 H: 9 B: C F A 5 H C B 7 C B H 5 B 9 8 B H: 6  
 8 F 5 K B: 6 H: 9 G C @ D F C D 9 F H M C:  
 O B G 9 F H 7 C A D 5 B M B 5 A 9 < 9 F 9 2 " 5 B M  
 F 9 D F C 8 1 7 H C B B D 5 F H C F 5 G 5 K < C @  
 K H: C 1 H H: 9 K F H 9 B D 9 F A 6 G C B C:  
 O B G 9 F H 7 C A D 5 B M B 5 A 9 < 9 F 9 2 G  
 D F C < 6 H 9 8 "

B 9 L H 5 G G M I G 9 8 C B  
 5 D D @ 7 5 H C B

I B @ G G C H: 9 F K 6 9 G D 9 7 @ 9 8.  
 8 A 9 B G C B G 5 F 9 B B 7 < 9 G  
 H C @ F 5 B 7 9 G  
 : F 5 7 H C B 5 @ ±  
 5 B: I @ 5 F: A 5 7 < ± ..... 6 9 B 8 ±  
 H K C D @ 5 7 9 8 9 7 A 5 @ ± ±  
 H: F 9 9 D @ 5 7 9 8 9 7 A 5 @ ± ±  
 B H 9 F D F 9 H: 9 C A 9 F 7  
 H C @ F 5 B 7 B: D 9 F.  
 A 5 H 9 F 5 @  
 : B 6 <  
 8 C B C H G 7 5 @ 9 8 F 5 K B:

	B 5 A 9	8 5 H 9
8 F 5 K B		
7 < 9 7 ? 9 8		
9 B: 5 D D F "		
A: : 5 D D F "		
E " 5 "		
7 C A A 9 B H G		

5 @ A B I A "\$ \$ \* ' ) "

H # @ .

J D % & ! G C : ! \* @ A ; ! K : ! K 9 H & + ?

G A 9	8 K ; " " B C "	F 9 J
<b>5</b>		
G 7 5 @ . % ' K 9 & < H ' G < 9 9 H - ' C : ' -		