

EVERGREEN LIGHTING

ALL BEND RADIUS .030"

APPLICATION

DO NOT SCALE DRAWING

UNLESS OTHERWISE SPECIFIED:

DIMENSIONS ARE IN INCHES
 TOLERANCES:
 FRACTIONAL ± .003
 ANGULAR: MACH ± .01 BEND ±
 TWO PLACE DECIMAL ±
 THREE PLACE DECIMAL ±.001

INTERPRET GEOMETRIC
 TOLERANCING PER:

MATERIAL

FINISH

NAME DATE

DRAWN
 CHECKED
 ENG APPR.
 MFG APPR.

Q.A.

COMMENTS:

TITLE:

BOL-LVR-PSS-12W-CA-43"-SBR-30K

SIZE	DWG. NO.	REV
A	TICKET 23849	

SCALE: 1:10	WEIGHT:	SHEET 1 OF 10
-------------	---------	---------------

5

4

3

2

1

ITEM NO.	PART NUMBER	DESCRIPTION	QTY.	CUT
1	BOL-LVR-PSS-12W-CA-43"-SBR-30K-6" CYLINDER	6" STAINLESS STEEL CYLINDER	1	
2	BOL-LVR-PSS-12W-CA-43"-SBR-30K-5" CYLINDER	STAINLESS STEEL 5"CYLINDER	1	
3	BOL-LVR-PSS-12W-CA-43"-SBR-30K-TUBE FLANGE	STAINLESS STEEL 0.250" PLATE	1	
4	BOL-LVR-PSS-12W-CA-43"-SBR-30K-TUBE PLATE	STAINLESS STEEL 0.250" PLATE	16	
5	BOL-LVR-PSS-12W-CA-43"-SBR-30K-SUPPORT PLATE	ALUMINUM 0.500" PLATE	1	
6	BOL-LVR-PSS-12W-CA-43"-SBR-30K-TUBE SLEEVE	SPUN STAINLESS STEEL 0.080"	1	
7	BOL-LVR-PSS-12W-CA-43"-SBR-30K-SPUN INNER CAP	SPUN STAINLESS STEEL 0.080"	1	
8	BOL-LVR-PSS-12W-CA-43"-SBR-30K-SPUN TOP CAP	SPUN STAINLESS STEEL 0.080"	1	
9	BOL-LVR-PSS-12W-CA-43"-SBR-30K-REFLECTOR LOUVER	SPUN ALUMINUM 0.0635"	6	
10	BOL-LVR-PSS-12W-CA-43"-SBR-30K-TUBE BRACKET	STAINLESS STEEL 0.080"	1	
11	BOL-LVR-PSS-12W-CA-43"-SBR-30K-LOUVER SPACER	ALUMINUM 0.0635"	1	
12	BOL-LVR-PSS-12W-CA-43"-SBR-30K-DRIVER BRACKET	ALUMINUM 0.0635"	1	
13	BOL-LVR-PSS-12W-CA-43"-SBR-30K-REFLECTOR SPACER	1/2" ALUMINUM ROUND TUBE	20	
14	BOL-LVR-PSS-12W-CA-43"-SBR-30K-REFLECTOR SUPPORT	0.250" ALUMINUM TUBE	4	
15	BOL-LVR-PSS-12W-CA-43"-SBR-30K-REFLECTOR SPACER BAR	1/2" ALUMINUM ROUND BAR	4	
16	BOL-LVR-PSS-12W-CA-43"-SBR-30K-CONNECTING TUBE	7/8"-1" STAINLESS STEEL ROUND TUBE	1	
17	BOL-LVR-PSS-12W-CA-43"-SBR-30K-LED TUBE	1" SQUARE ALUMINUM TUBE	1	
18	BOL-LVR-PSS-12W-CA-43"-SBR-30K-ACRYLIC TUBE	ACRYLIC LENS	1	
19	KTLD-15-UV-PS350-42-VDIM-LP1	DRIVER	1	
20	Alttailed_PN1012_RevD	LED	4	

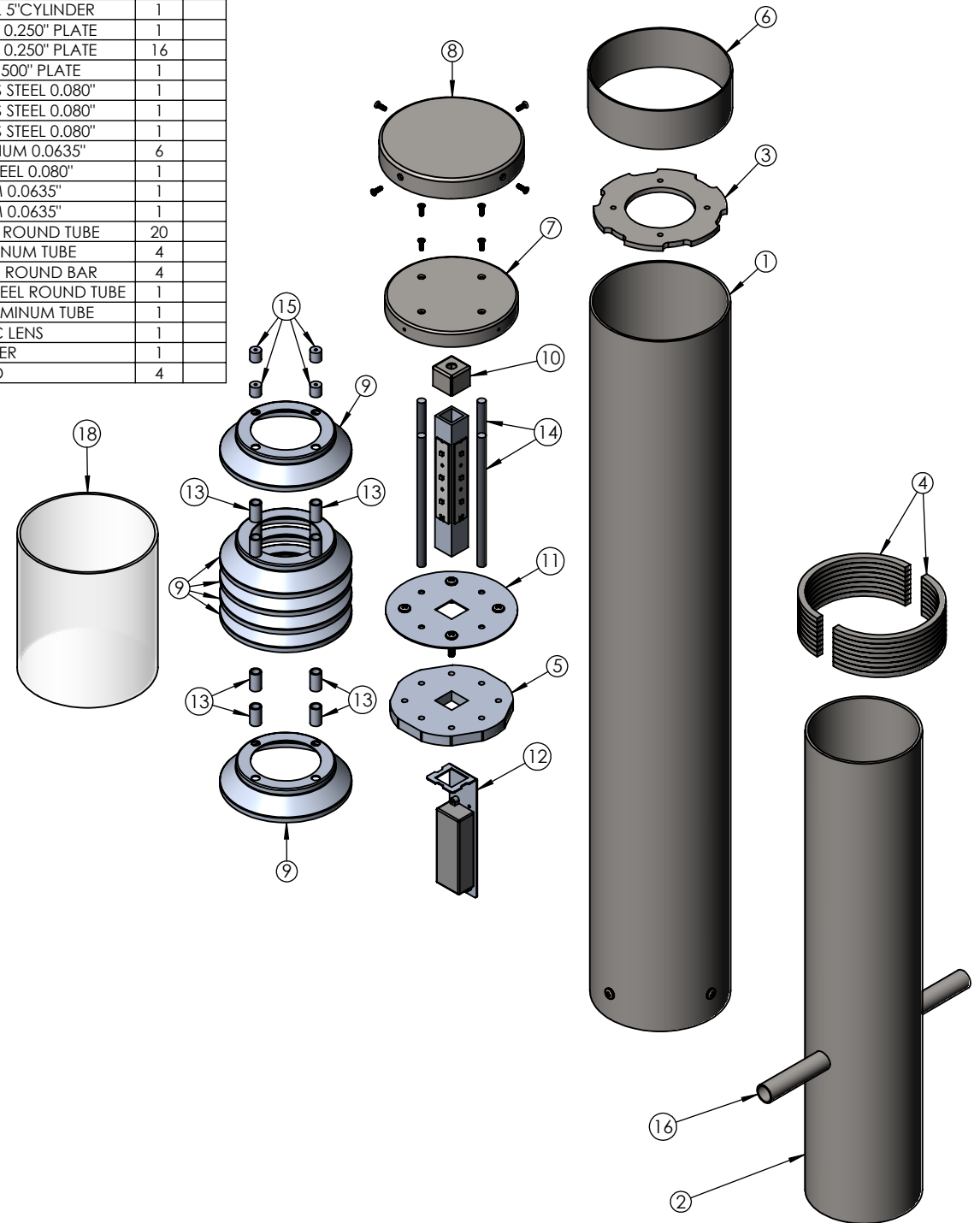

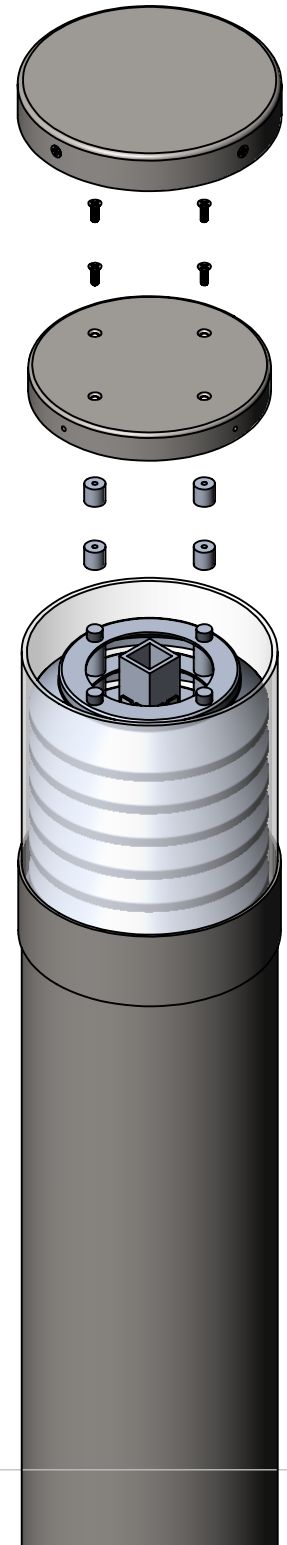
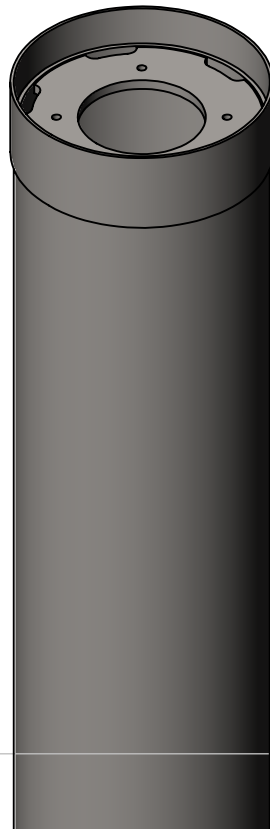
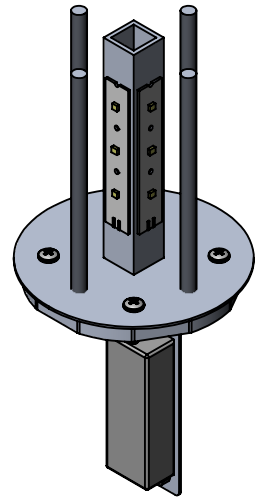
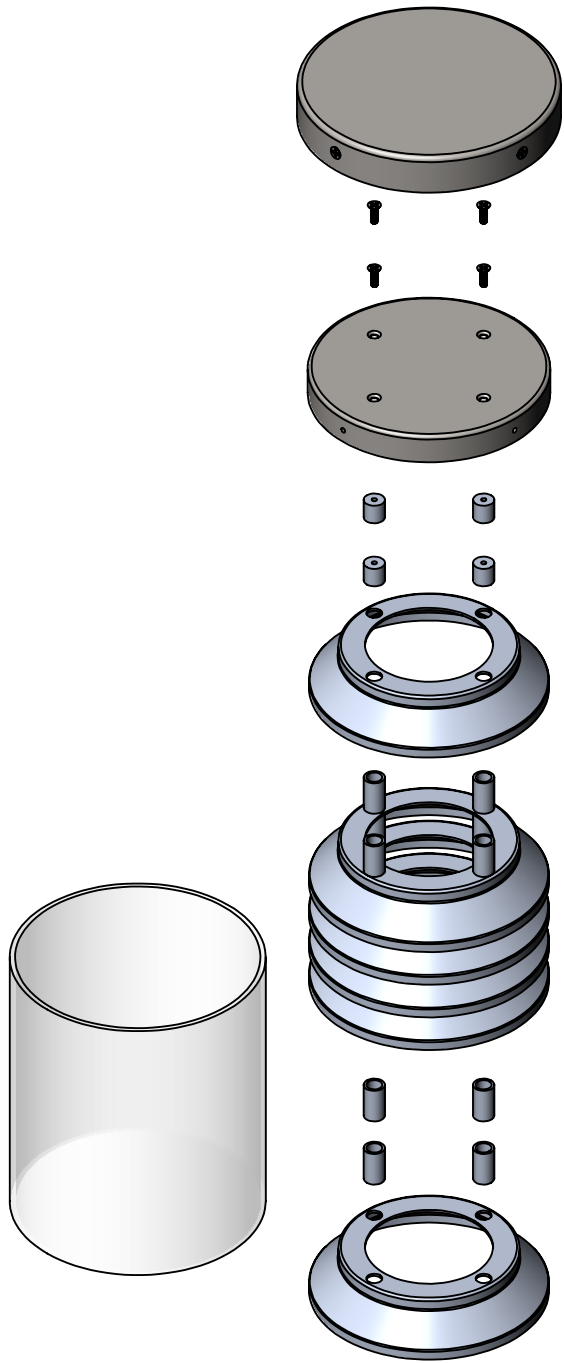

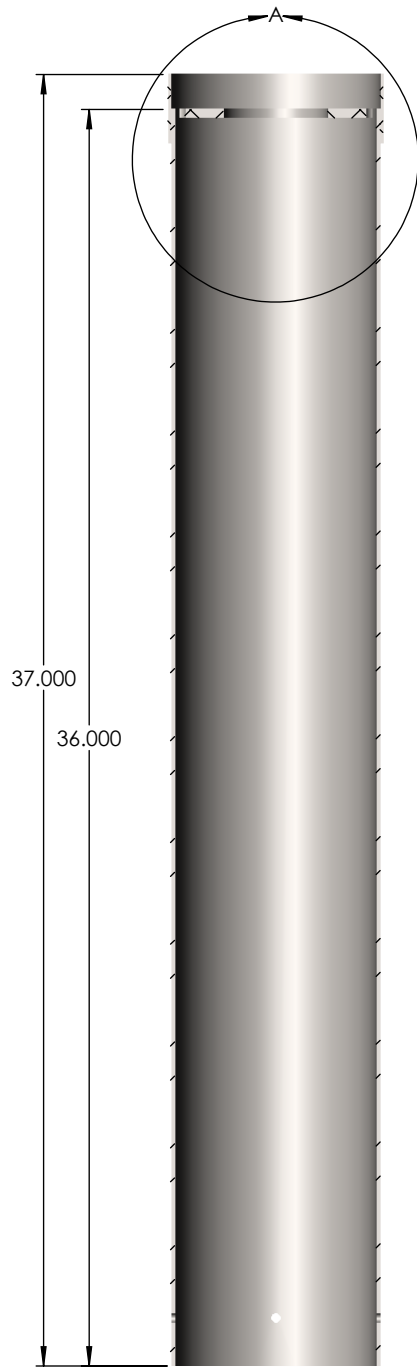
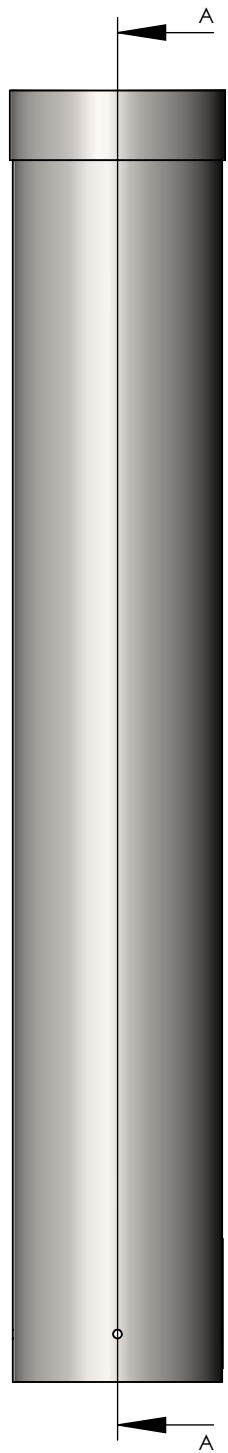

SECTION A-A

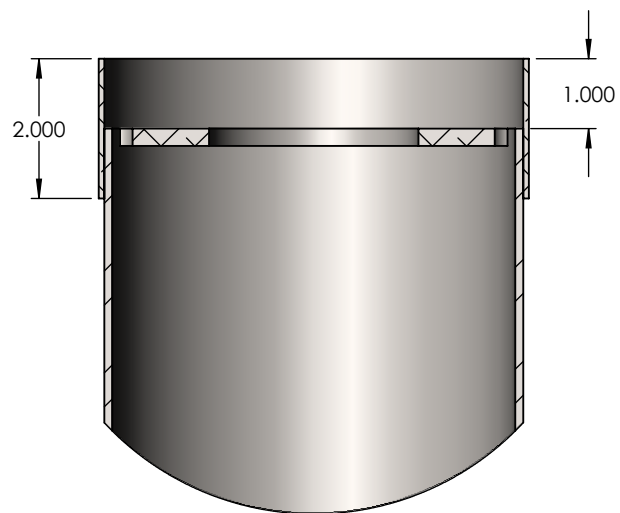

DETAIL A
SCALE 2 : 5.5



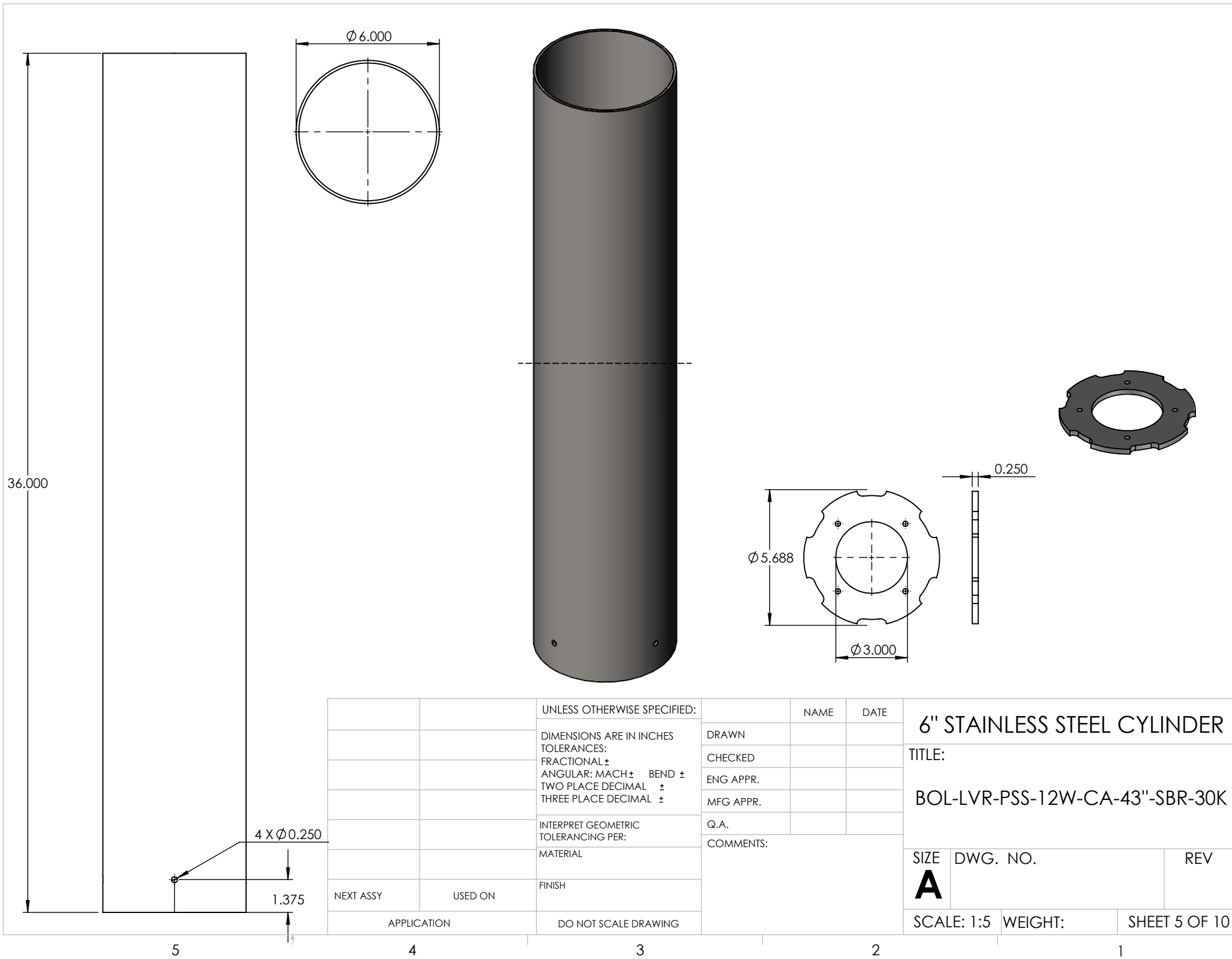

		UNLESS OTHERWISE SPECIFIED:	NAME	DATE	6" STAINLESS STEEL CYLINDER	
		DIMENSIONS ARE IN INCHES	DRAWN		TITLE:	
		TOLERANCES:	CHECKED		BOL-LVR-PSS-12W-CA-43"-SBR-30K	
		FRACTIONAL ±	ENG APPR.		SIZE	DWG. NO.
		ANGULAR: MACH ± BEND ±	MFG APPR.		A	REV
		TWO PLACE DECIMAL ±	Q.A.		SCALE: 1:5	WEIGHT:
		THREE PLACE DECIMAL ±	COMMENTS:			SHEET 5 OF 10
		INTERPRET GEOMETRIC TOLERANCING PER:				
		MATERIAL				
		FINISH				
NEXT ASSY	USED ON					
APPLICATION	DO NOT SCALE DRAWING					

5

4

3

2

1

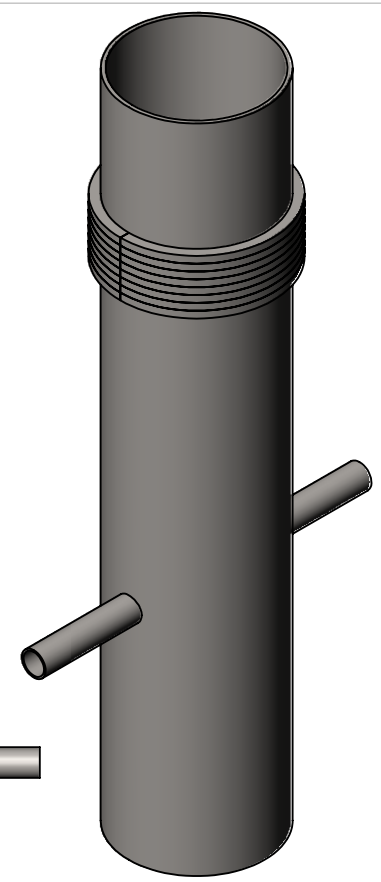
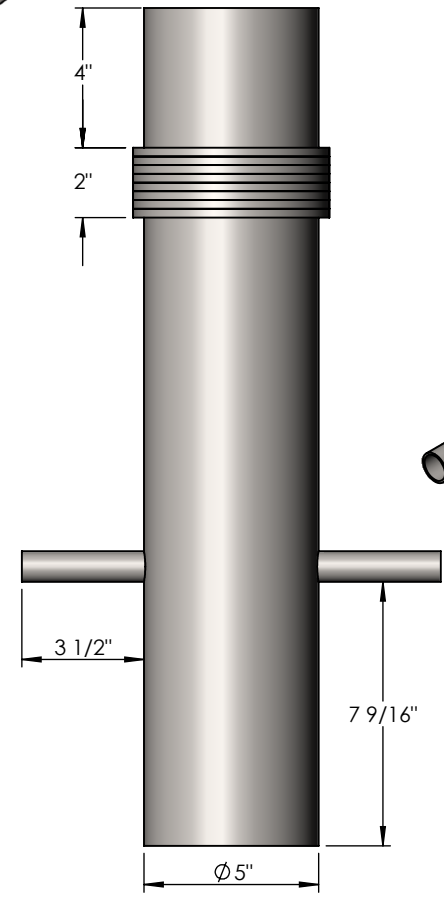
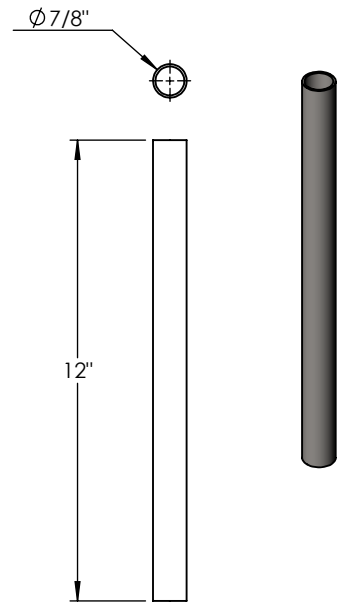
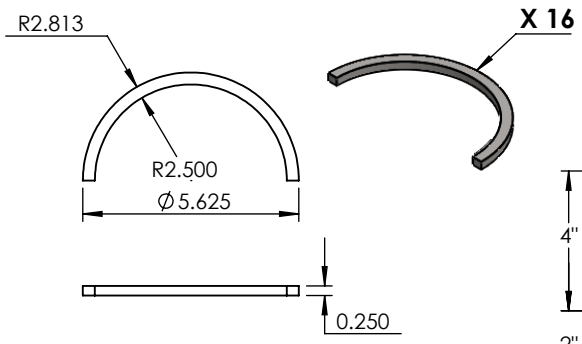
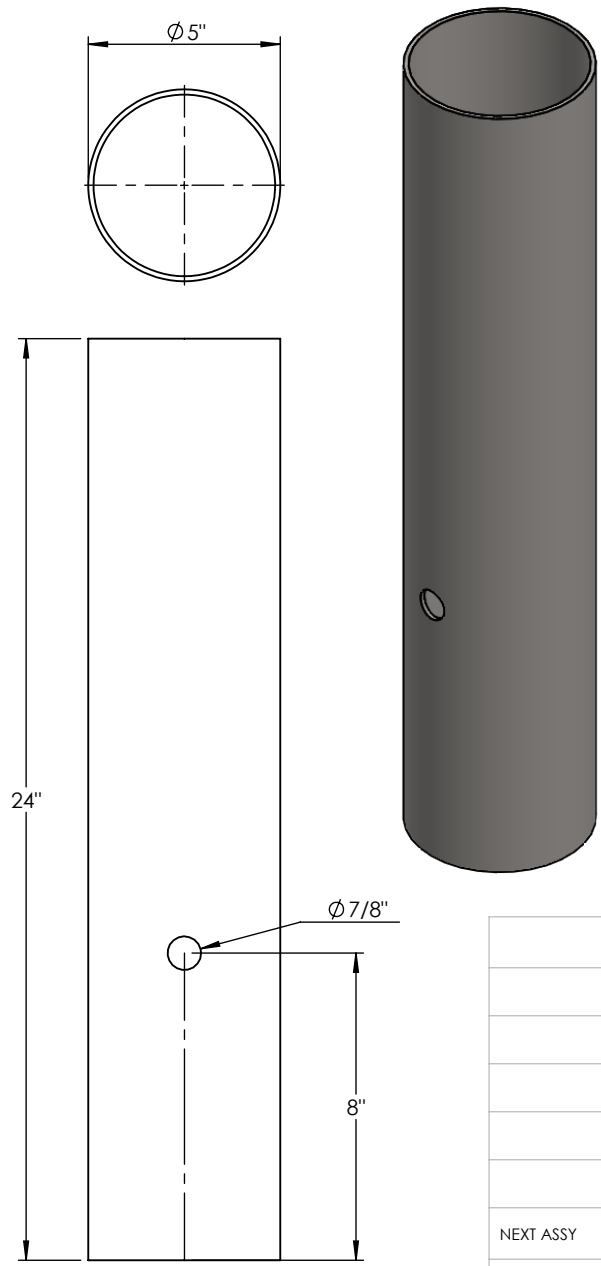

		UNLESS OTHERWISE SPECIFIED:	NAME	DATE
		DIMENSIONS ARE IN INCHES	DRAWN	
		TOLERANCES:	CHECKED	
		FRACTIONAL ±	ENG APPR.	
		ANGULAR: MACH ± BEND ±	MFG APPR.	
		TWO PLACE DECIMAL ±	Q.A.	
		THREE PLACE DECIMAL ±	COMMENTS:	
		INTERPRET GEOMETRIC TOLERANCING PER:		
		MATERIAL		
		FINISH		
NEXT ASSY	USED ON			
APPLICATION	DO NOT SCALE DRAWING			

STAINLESS STEEL 5"CYLINDER		
TITLE:		
BOL-LVR-PSS-12W-CA-43"-SBR-30K		
SIZE	DWG. NO.	REV
A		
SCALE: 1:5	WEIGHT:	SHEET 6 OF 10

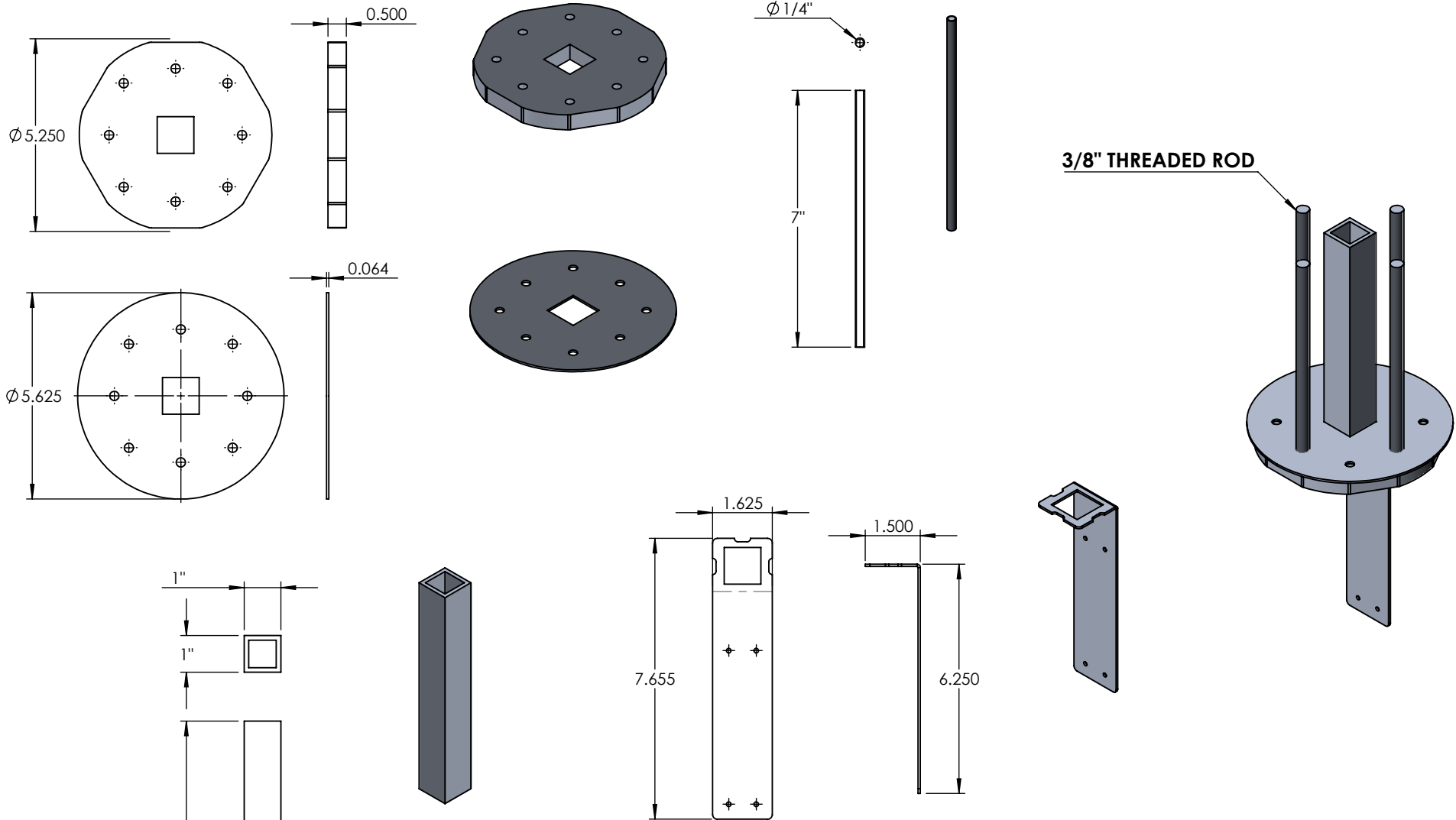

PROPRIETARY AND CONFIDENTIAL
 THE INFORMATION CONTAINED IN THIS DRAWING IS THE SOLE PROPERTY OF <INSERT COMPANY NAME HERE>. ANY REPRODUCTION IN PART OR AS A WHOLE WITHOUT THE WRITTEN PERMISSION OF <INSERT COMPANY NAME HERE> IS PROHIBITED.

		UNLESS OTHERWISE SPECIFIED:		NAME	DATE
		DIMENSIONS ARE IN INCHES	DRAWN		
		TOLERANCES:	CHECKED		
		FRACTIONAL ±	ENG APPR.		
		ANGULAR: MACH ± BEND ±	MFG APPR.		
		TWO PLACE DECIMAL ±	Q.A.		
		THREE PLACE DECIMAL ±	COMMENTS:		
		INTERPRET GEOMETRIC TOLERANCING PER:			
		MATERIAL			
		FINISH			
NEXT ASSY	USED ON				
APPLICATION	DO NOT SCALE DRAWING				

ALUMINUM 0.500" PLATE		
TITLE:		
BOL-LVR-PSS-12W-CA-43"-SBR-30K		
SIZE	DWG. NO.	REV
A		
SCALE: 1:4	WEIGHT:	SHEET 7 OF 10

ITEM NO.	PART NUMBER	DESCRIPTION	QTY.
1	BOL-LVR-PSS-12W-CA-43"-SBR-30K-REFLECTOR LOUVER	SPUN ALUMINUM 0.0635"	1

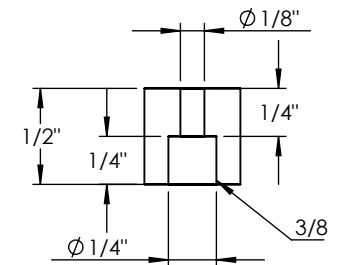
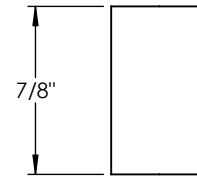
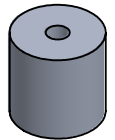
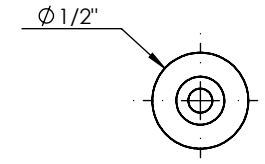
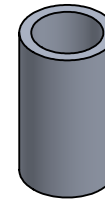
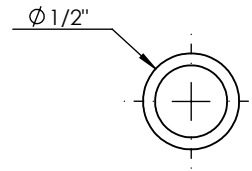
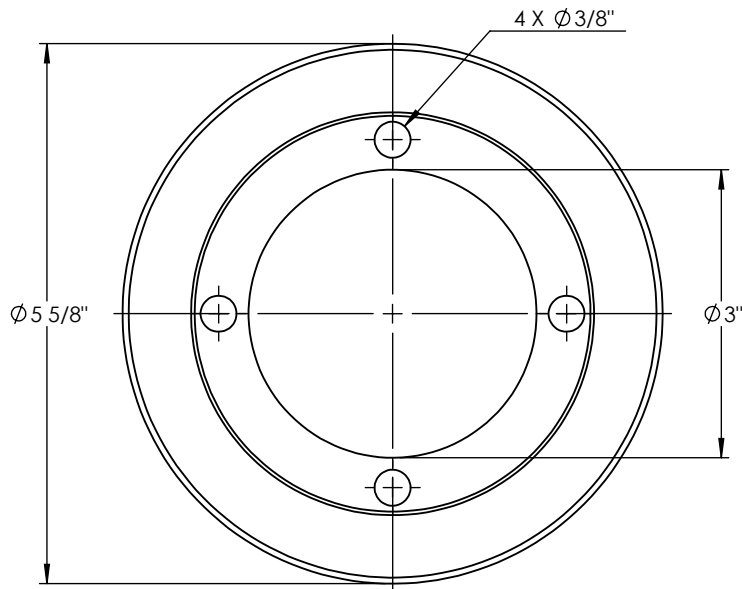
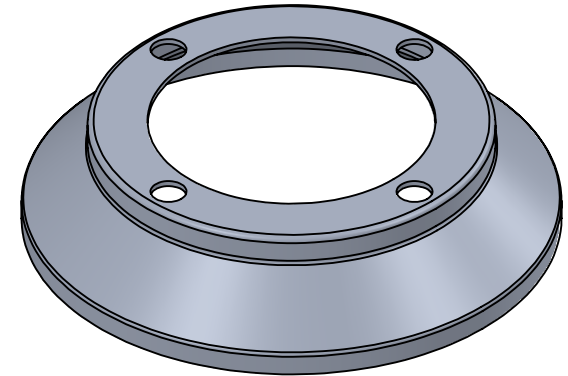
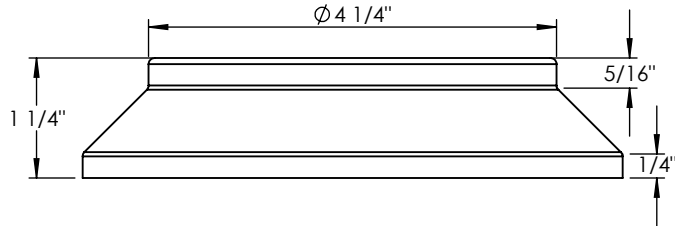

PROPRIETARY AND CONFIDENTIAL
 THE INFORMATION CONTAINED IN THIS DRAWING IS THE SOLE PROPERTY OF <INSERT COMPANY NAME HERE>. ANY REPRODUCTION IN PART OR AS A WHOLE WITHOUT THE WRITTEN PERMISSION OF <INSERT COMPANY NAME HERE> IS PROHIBITED.

		UNLESS OTHERWISE SPECIFIED:	NAME	DATE
		DIMENSIONS ARE IN INCHES TOLERANCES: FRACTIONAL ± ANGULAR: MACH ± BEND ± TWO PLACE DECIMAL ± THREE PLACE DECIMAL ±	DRAWN	
		INTERPRET GEOMETRIC TOLERANCING PER:	CHECKED	
		MATERIAL	ENG APPR.	
		FINISH	MFG APPR.	
NEXT ASSY	USED ON		Q.A.	
APPLICATION	DO NOT SCALE DRAWING		COMMENTS:	

SPUN ALUMINUM 0.0635"

TITLE:
 BOL-LVR-PSS-12W-CA-43"-SBR-30K

SIZE DWG. NO. REV
A

SCALE: 1:2 WEIGHT: SHEET 8 OF 10

ITEM NO.	PART NUMBER	DESCRIPTION	QTY.
1	BOL-LVR-PSS-12W-CA-43"-SBR-30K-TUBE SLEEVE	SPUN STAINLESS STEEL 0.080"	1

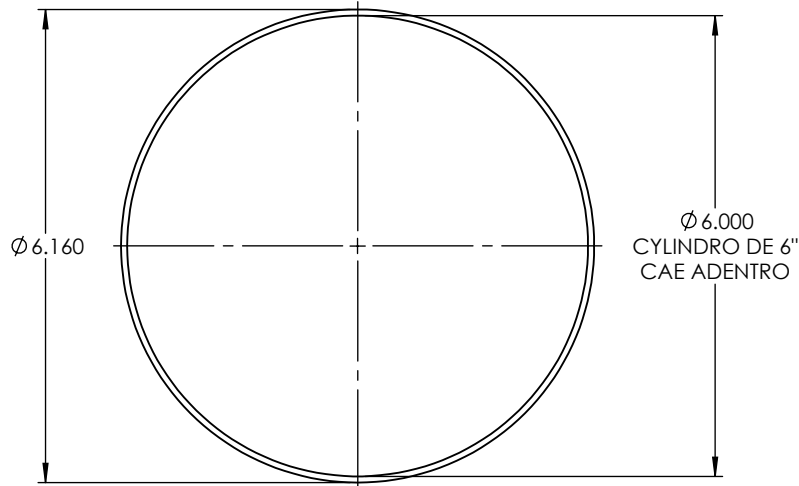
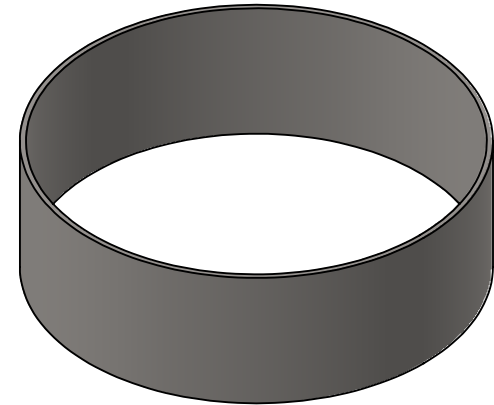

PROPRIETARY AND CONFIDENTIAL
THE INFORMATION CONTAINED IN THIS DRAWING IS THE SOLE PROPERTY OF <INSERT COMPANY NAME HERE>. ANY REPRODUCTION IN PART OR AS A WHOLE WITHOUT THE WRITTEN PERMISSION OF <INSERT COMPANY NAME HERE> IS PROHIBITED.

		UNLESS OTHERWISE SPECIFIED:	NAME	DATE	SPUN STAINLESS STEEL 0.080"	
		DIMENSIONS ARE IN INCHES	DRAWN		TITLE:	
		TOLERANCES:	CHECKED		BOL-LVR-PSS-12W-CA-43"-SBR-30K	
		FRACTIONAL ±	ENG APPR.		SIZE DWG. NO. REV	
		ANGULAR: MACH ± BEND ±	MFG APPR.		SCALE: 1:2.5 WEIGHT: SHEET 9 OF 10	
		TWO PLACE DECIMAL ±	Q.A.			
		THREE PLACE DECIMAL ±	COMMENTS:			
		INTERPRET GEOMETRIC TOLERANCING PER:				
		MATERIAL				
NEXT ASSY	USED ON	FINISH				
APPLICATION		DO NOT SCALE DRAWING				

5

4

3

2

1

PROPRIETARY AND CONFIDENTIAL
 THE INFORMATION CONTAINED IN THIS
 DRAWING IS THE SOLE PROPERTY OF
 <INSERT COMPANY NAME HERE>. ANY
 REPRODUCTION IN PART OR AS A WHOLE
 WITHOUT THE WRITTEN PERMISSION OF
 <INSERT COMPANY NAME HERE> IS
 PROHIBITED.

		UNLESS OTHERWISE SPECIFIED:		NAME	DATE	
		DIMENSIONS ARE IN INCHES TOLERANCES: FRACTIONAL ± ANGULAR: MACH ± BEND ± TWO PLACE DECIMAL ± THREE PLACE DECIMAL ±	DRAWN			TITLE: BOL-LVR-PSS-12W-CA-43"-SBR-30K
			CHECKED			
			ENG APPR.			
			MFG APPR.			
		INTERPRET GEOMETRIC TOLERANCING PER:	Q.A.			
		MATERIAL	COMMENTS:			
		FINISH				SIZE DWG. NO. REV
NEXT ASSY	USED ON					A
APPLICATION		DO NOT SCALE DRAWING				SCALE: 1:2.5 WEIGHT: SHEET 10 OF 10

5

4

3

2

1