

ITEM NO.	PART NUMBER	DESCRIPTION	QTY.	CUT
1	30609-11-CSTSTP-48"-DD-FIREPLATE	ALUMINUM 0.125" PLATE	1	
2	30609-11-CSTSTP-48"-DD-10X10 BOLLARD BODY	ALUMINUM 0.125" PLATE	2	
3	30609-11-CSTSTP-48"-DD-INSIDE BODY PLATE	ALUMINUM 0.0635"	1	
4	30609-11-CSTSTP-48"-DD-HEAD TRIM BASE	ALUMINUM 0.0635"	1	
5	30609-11-CSTSTP-48"-DD-HEAD BASE FRAME	ALUMINUM 0.0635"	1	
6	30609-11-CSTSTP-48"-DD-HEAD BASE BACK	ALUMINUM 0.0635"	1	
7	30609-11-CSTSTP-48"-DD-HEAD BASE TOP	ALUMINUM 0.0635"	1	
8	30609-11-CSTSTP-48"-DD-18X18 TRIANGLE CAP	ALUMINUM 0.0635"	1	
9	30609-11-CSTSTP-48"-DD-LED MOUNTING PLATE	22 GAUGE	1	
10	30609-11-CSTSTP-48"-DD-DRIVER BRACKET	22 GAUGE	1	
11	30609-11-CSTSTP-48"-DD-TRIANGLE FLANGE	25 GAUGE	4	
12	F42TBX-835-A-ECO	BULB	1	
13	30609-11-CSTSTP-48"-DD-ACRYLIC	ACRYLIC	4	
14	AC-CDS-UV42PS DRIVER	EMR DRIVER	1	

UNLESS OTHERWISE SPECIFIED:

DIMENSIONS ARE IN INCHES
 TOLERANCES:
 FRACTIONAL ± .003
 ANGULAR: MACH ± .01 BEND ±
 TWO PLACE DECIMAL ±
 THREE PLACE DECIMAL ± .001

INTERPRET GEOMETRIC
 TOLERANCING PER:

MATERIAL

FINISH

NAME DATE

DRAWN

CHECKED

ENG APPR.

MFG APPR.

Q.A.

COMMENTS:

TITLE:

30609-11-CSTSTP-48"-DD

SIZE DWG. NO. REV

A TICKET 23902

SCALE: 1:12 WEIGHT: SHEET 1 OF 13

ALL BEND RADIUS .030"

APPLICATION

DO NOT SCALE DRAWING



EVERGREEN LIGHTING

5

4

3

2

1

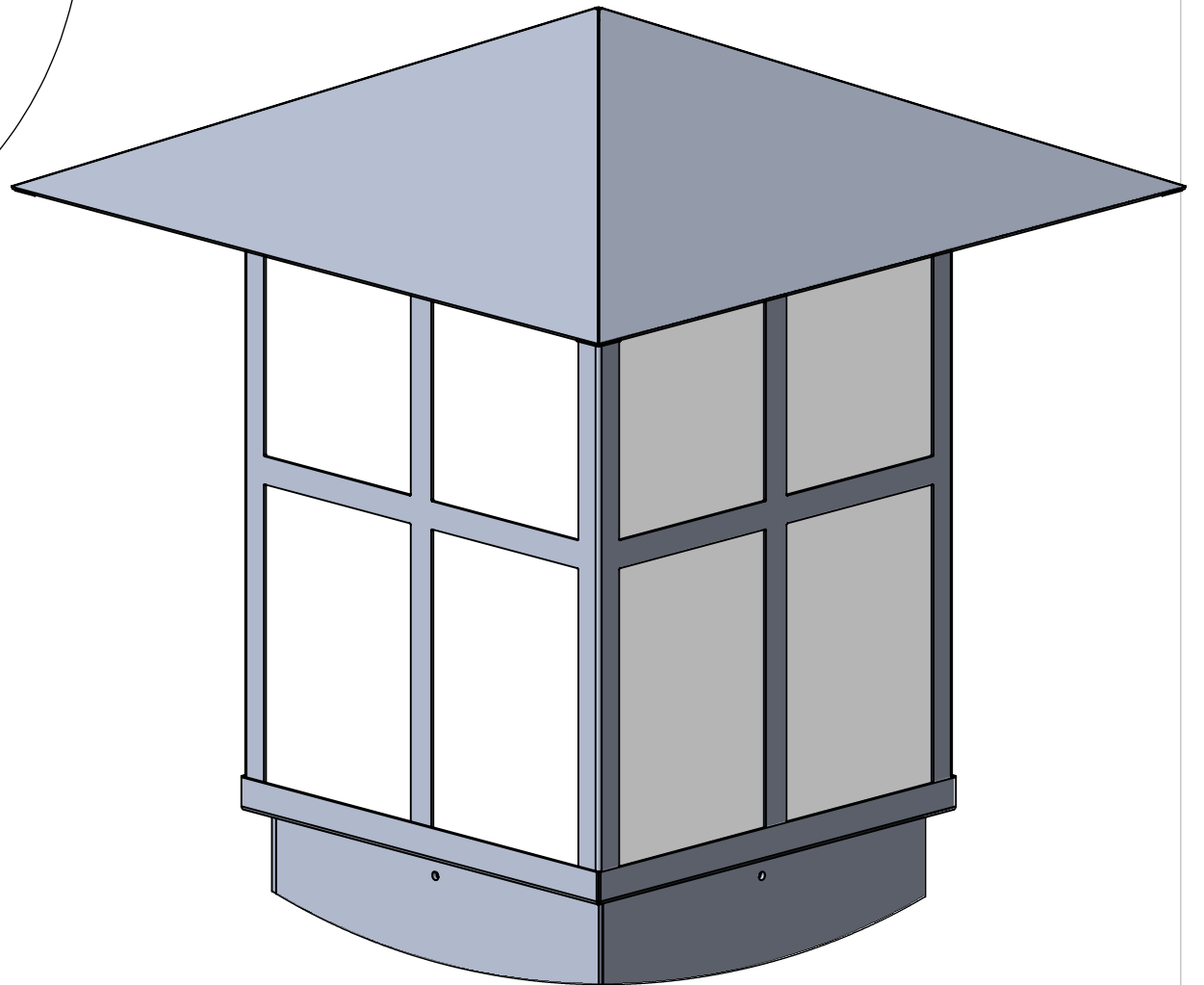
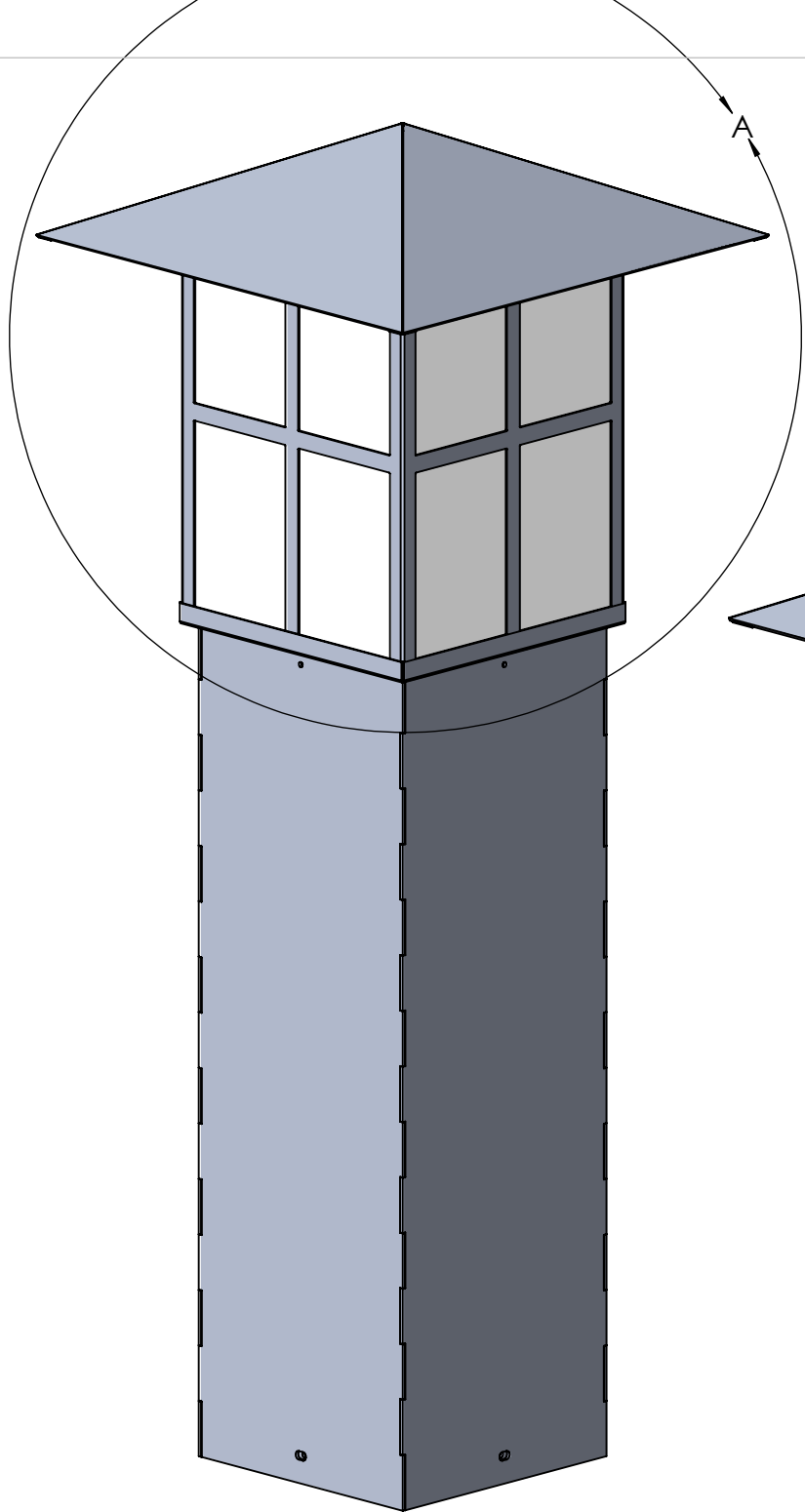

DETAIL A
SCALE 1 : 4

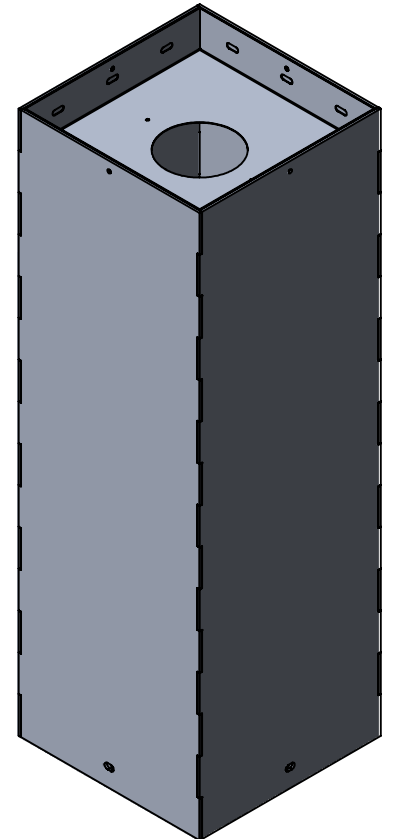
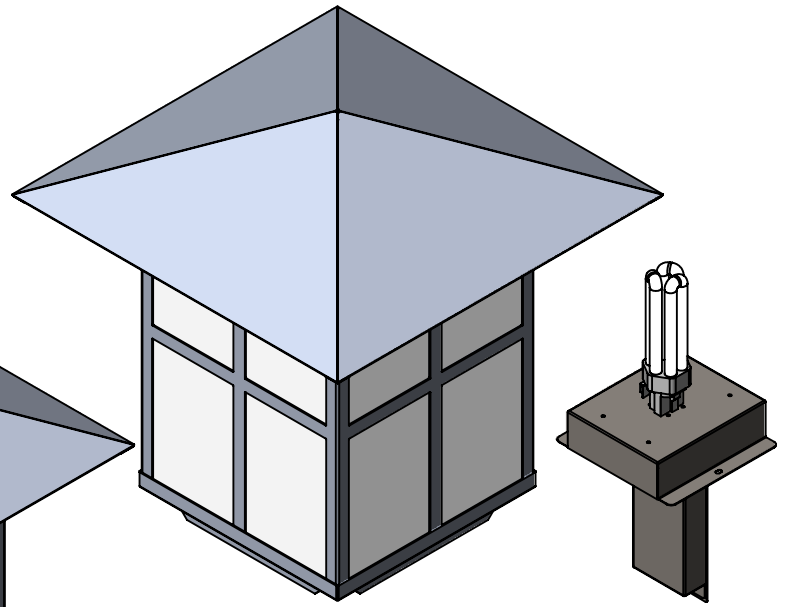
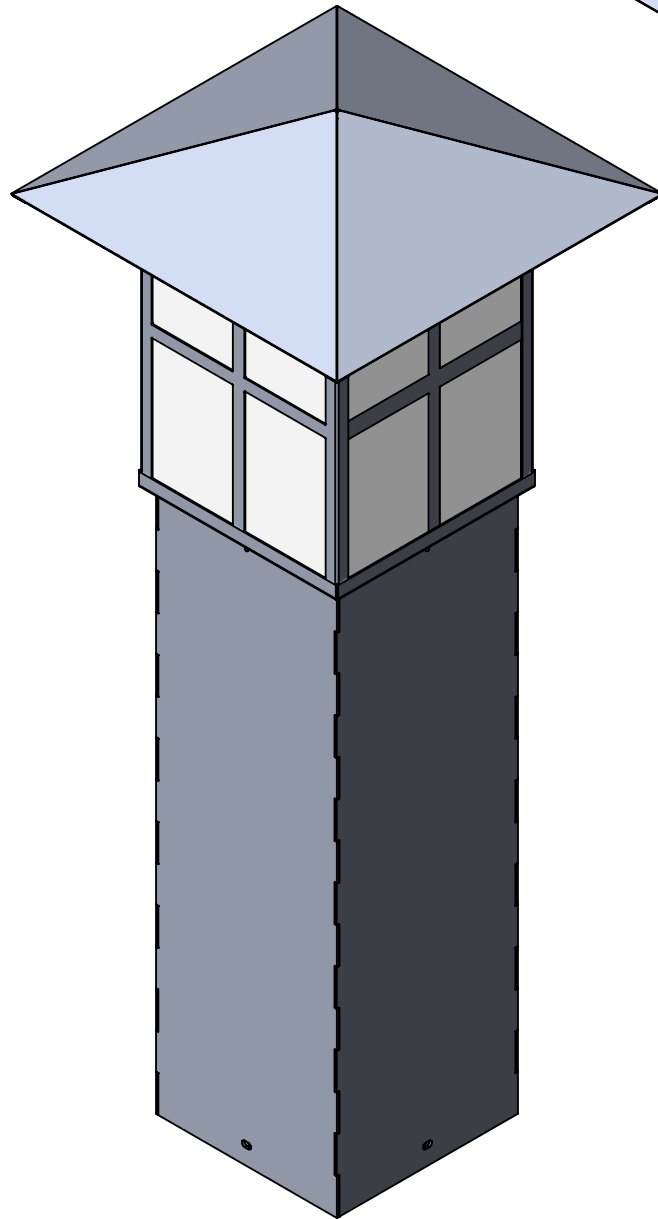
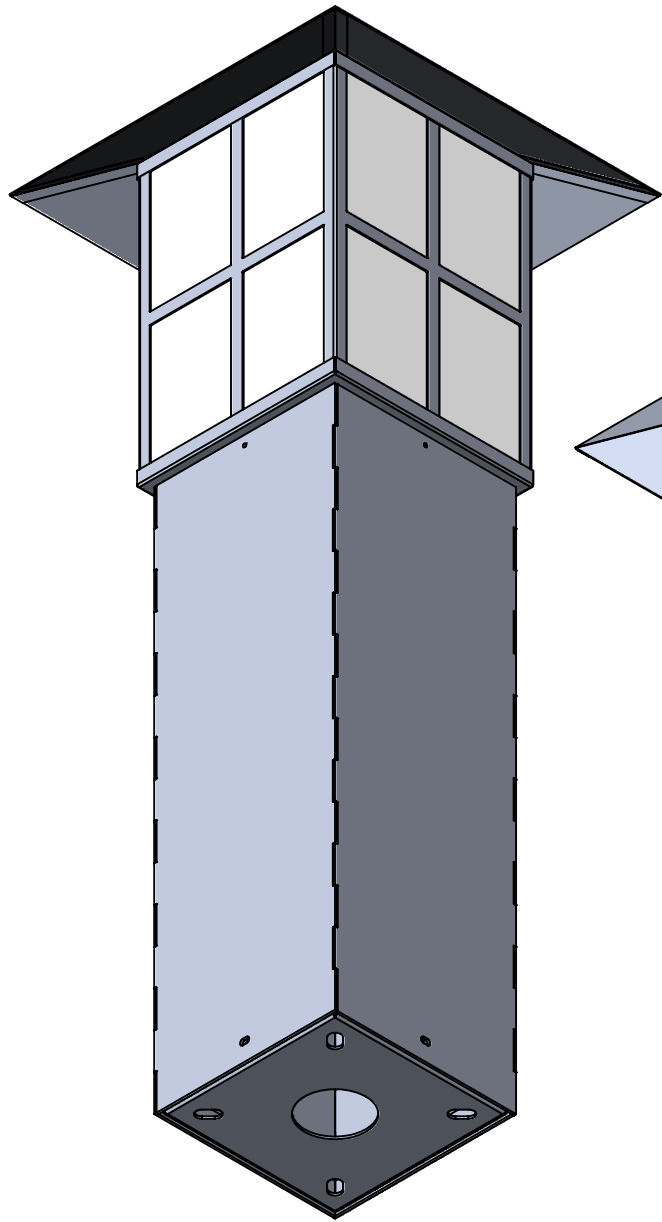

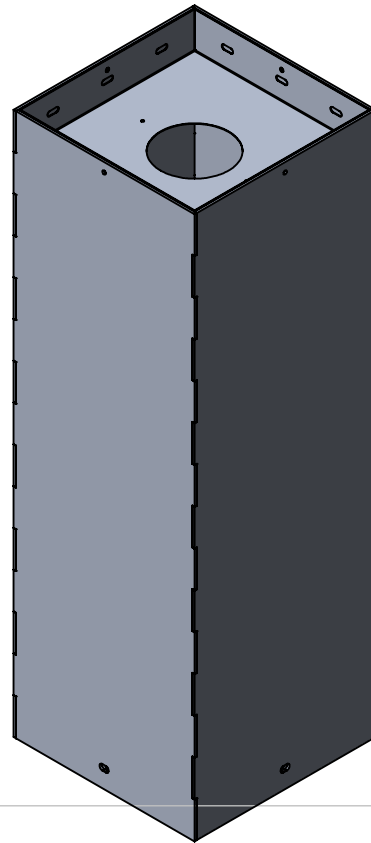
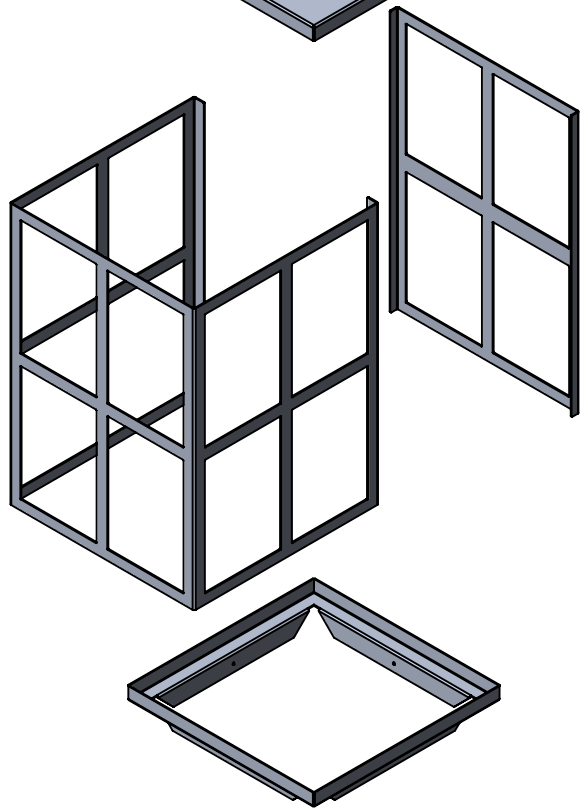
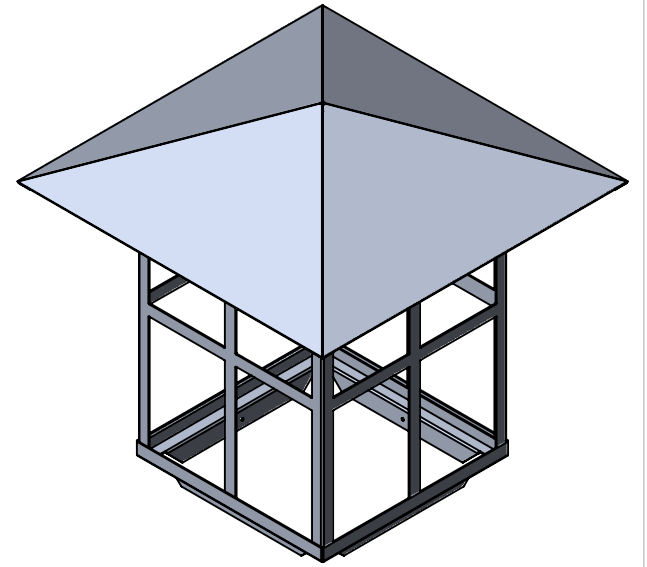
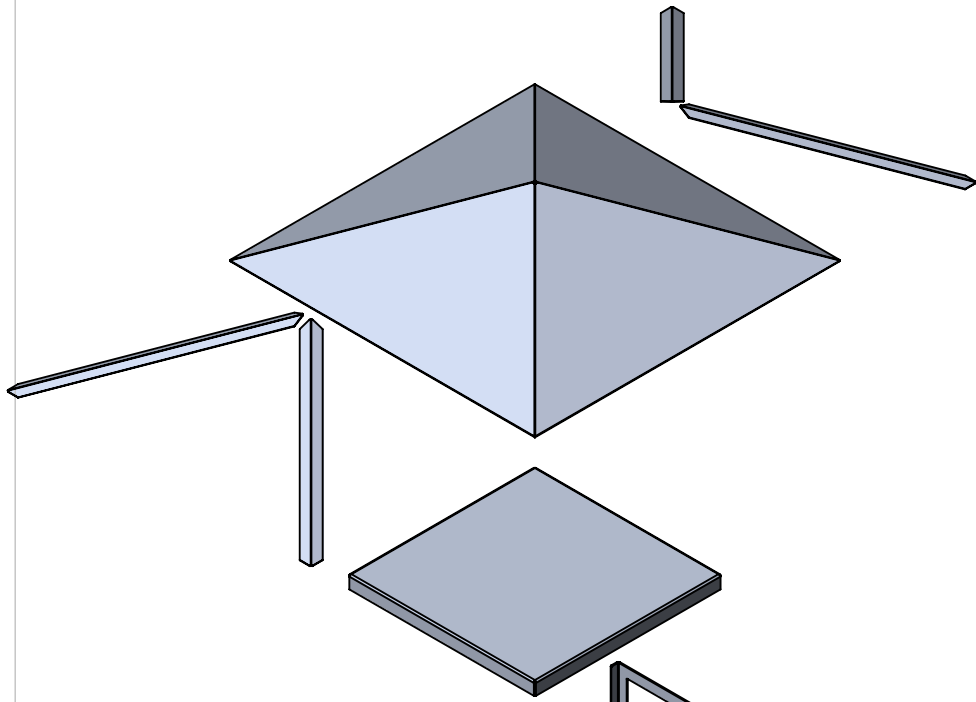

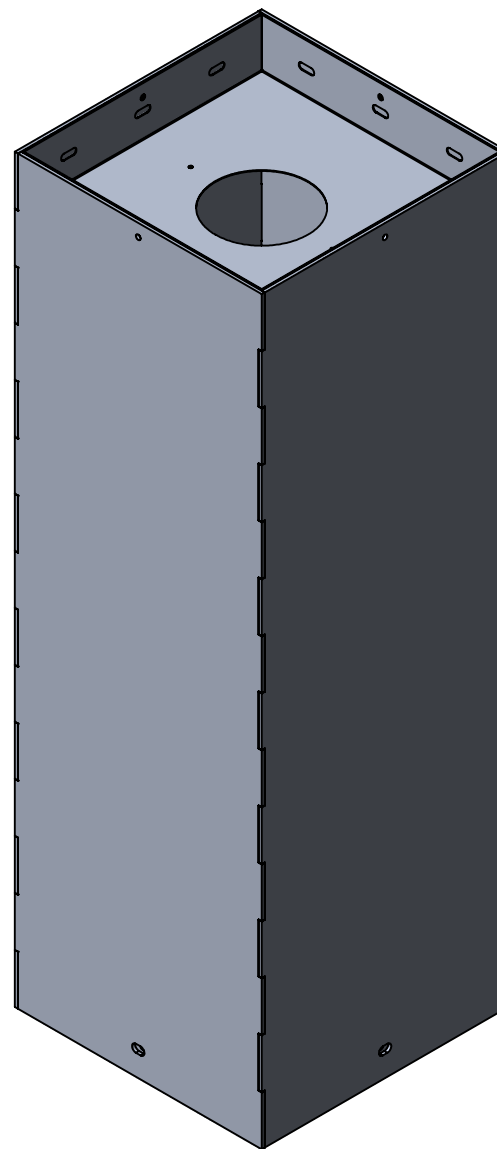
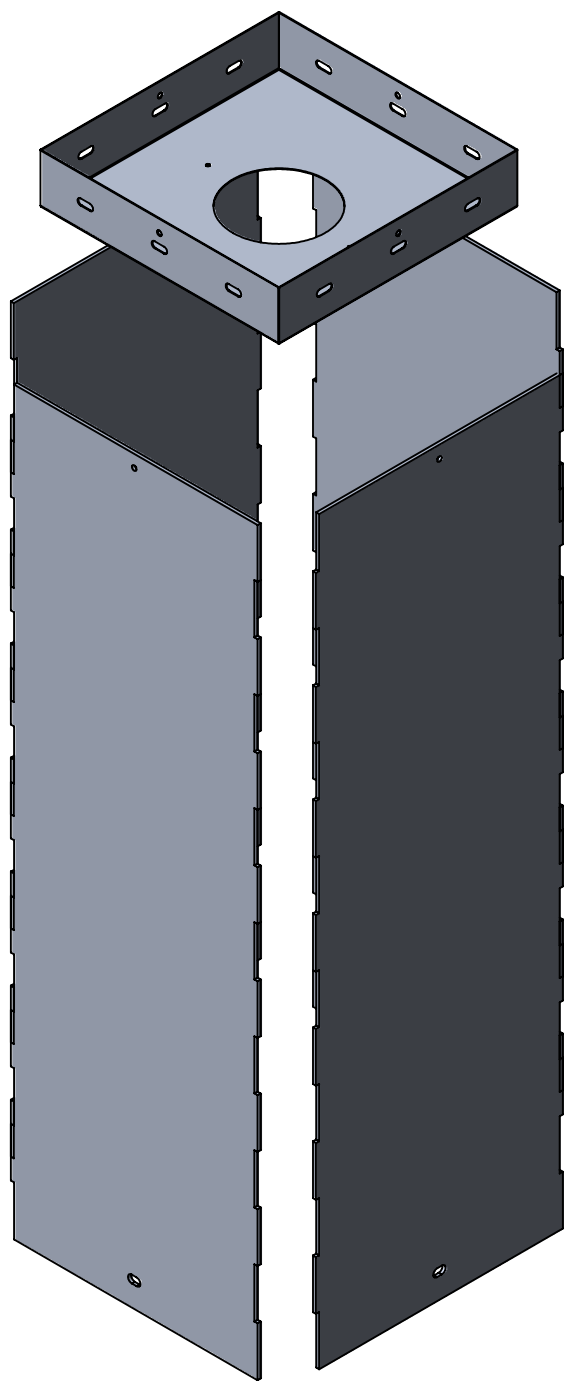

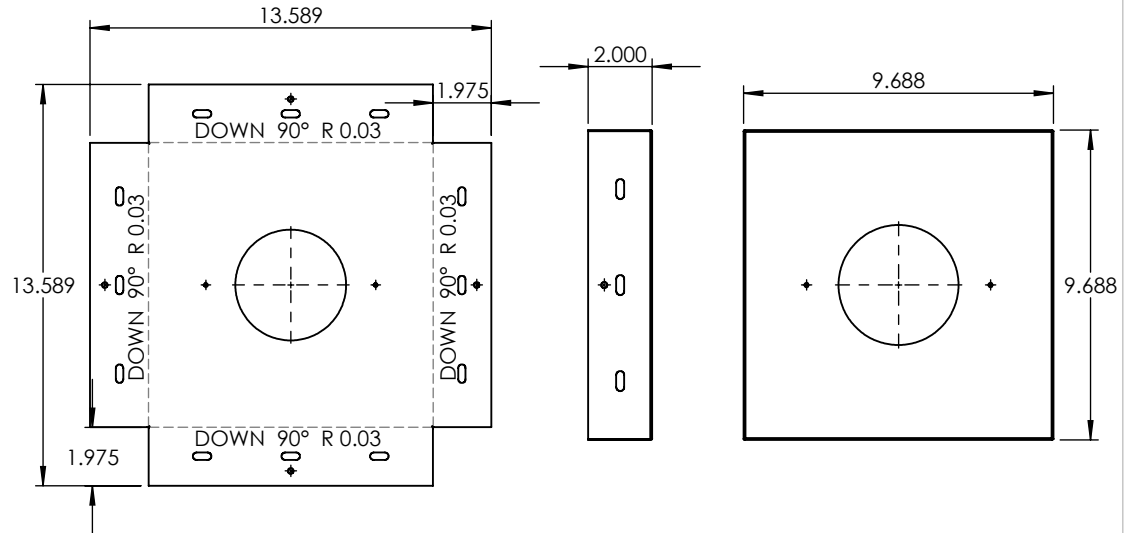
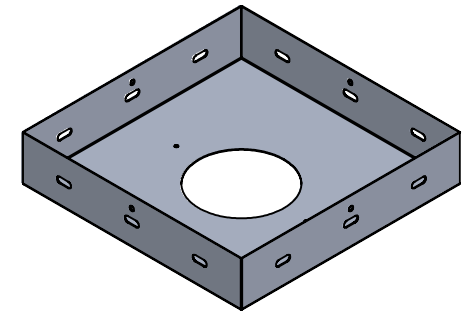
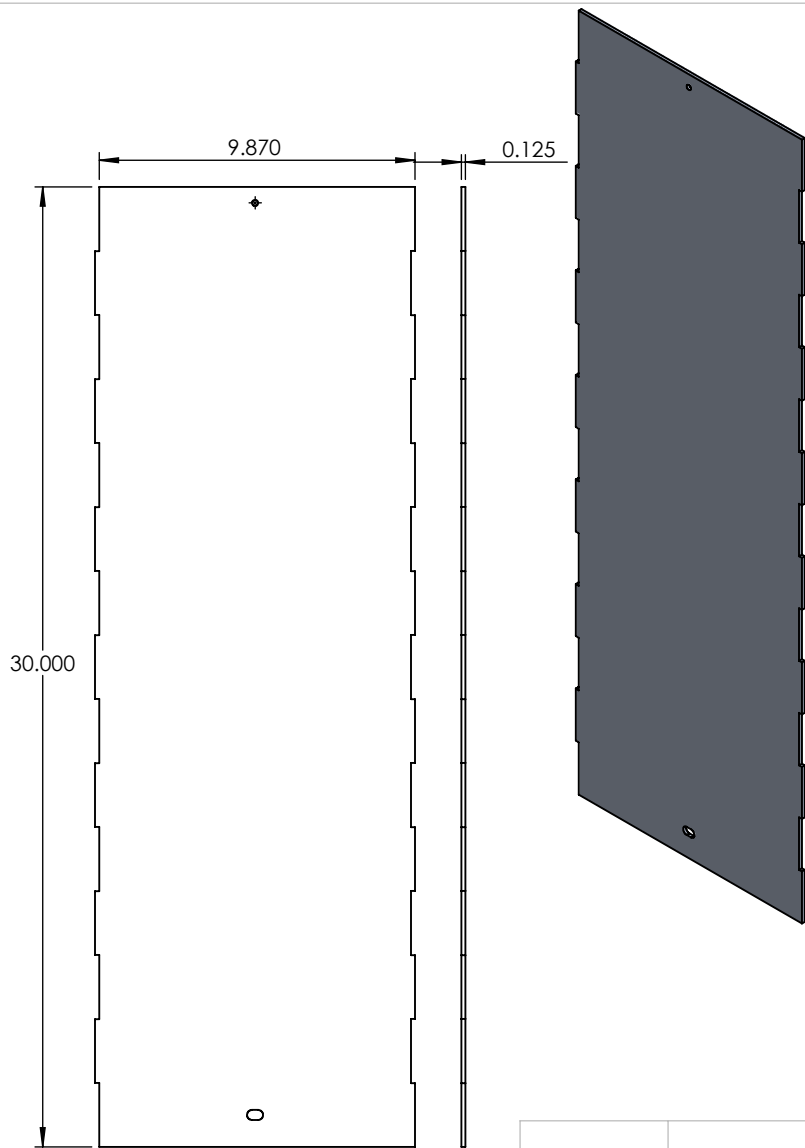

PROPRIETARY AND CONFIDENTIAL
 THE INFORMATION CONTAINED IN THIS DRAWING IS THE SOLE PROPERTY OF <INSERT COMPANY NAME HERE>. ANY REPRODUCTION IN PART OR AS A WHOLE WITHOUT THE WRITTEN PERMISSION OF <INSERT COMPANY NAME HERE> IS PROHIBITED.

		UNLESS OTHERWISE SPECIFIED:	NAME	DATE	ALUMINUM 0.125" PLATE		
		DIMENSIONS ARE IN INCHES TOLERANCES: FRACTIONAL ± ANGULAR: MACH ± BEND ± TWO PLACE DECIMAL ± THREE PLACE DECIMAL ±	DRAWN				TITLE:
		INTERPRET GEOMETRIC TOLERANCING PER:	CHECKED		30609-11-CSTSTP-48"-DD		
		MATERIAL	ENG APPR.				
		FINISH	MFG APPR.		SIZE	DWG. NO.	REV
NEXT ASSY	USED ON		Q.A.		A		
APPLICATION		DO NOT SCALE DRAWING	COMMENTS:			SCALE: 1:6	WEIGHT:

5

4

3

2

1

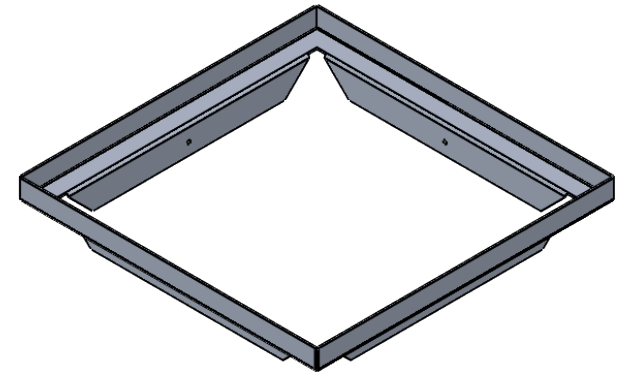
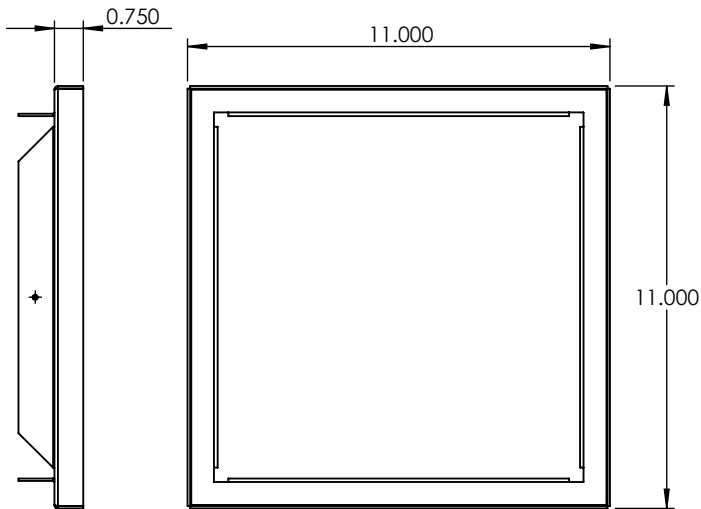
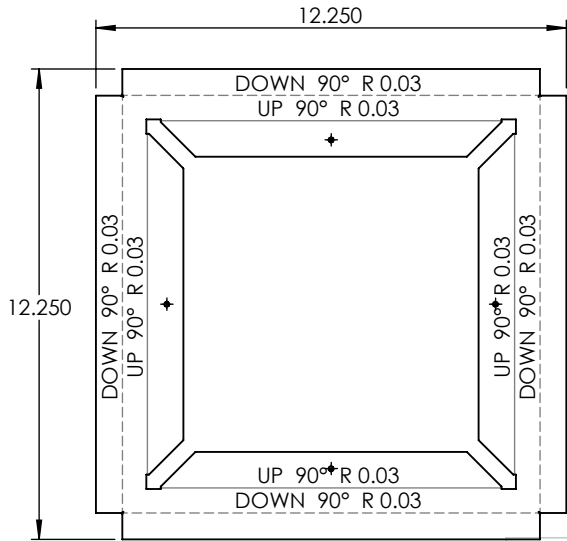
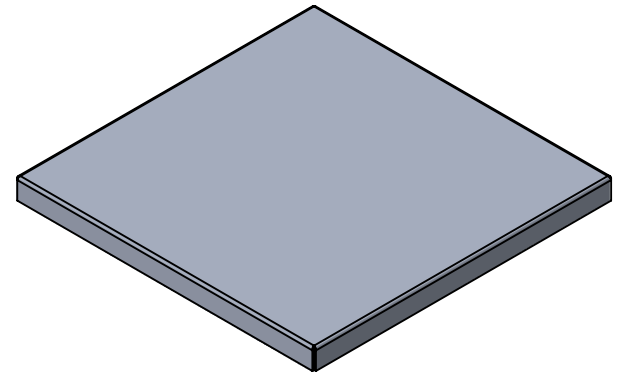
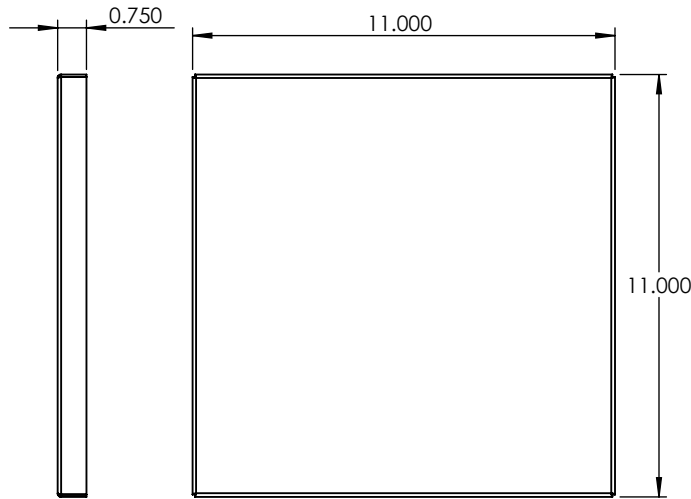
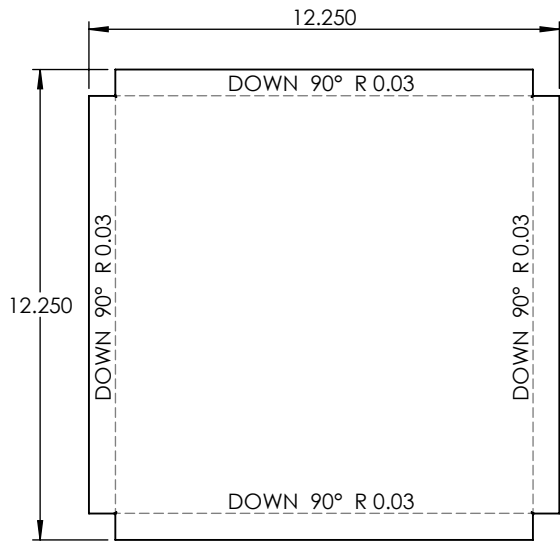

PROPRIETARY AND CONFIDENTIAL
 THE INFORMATION CONTAINED IN THIS DRAWING IS THE SOLE PROPERTY OF <INSERT COMPANY NAME HERE>. ANY REPRODUCTION IN PART OR AS A WHOLE WITHOUT THE WRITTEN PERMISSION OF <INSERT COMPANY NAME HERE> IS PROHIBITED.

		UNLESS OTHERWISE SPECIFIED:		NAME	DATE
		DIMENSIONS ARE IN INCHES	DRAWN		
		TOLERANCES:	CHECKED		
		FRACTIONAL ±	ENG APPR.		
		ANGULAR: MACH ± BEND ±	MFG APPR.		
		TWO PLACE DECIMAL ±	Q.A.		
		THREE PLACE DECIMAL ±	COMMENTS:		
		INTERPRET GEOMETRIC TOLERANCING PER:			
		MATERIAL			
	NEXT ASSY	FINISH			
		USED ON			
	APPLICATION	DO NOT SCALE DRAWING			

ALUMINUM 0.0635"

TITLE:

30609-11-CSTSTP-48"-DD

SIZE	DWG. NO.	REV
A		

SCALE: 1:5 WEIGHT: SHEET 7 OF 13

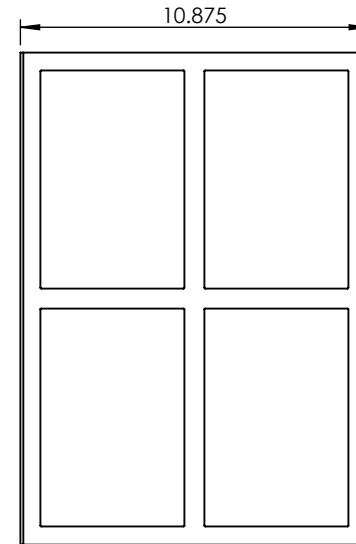
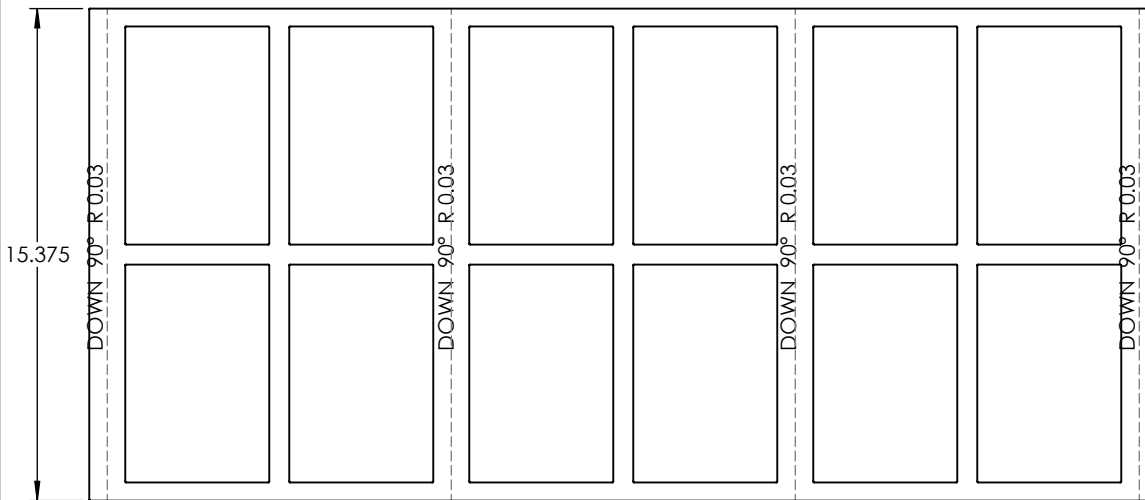
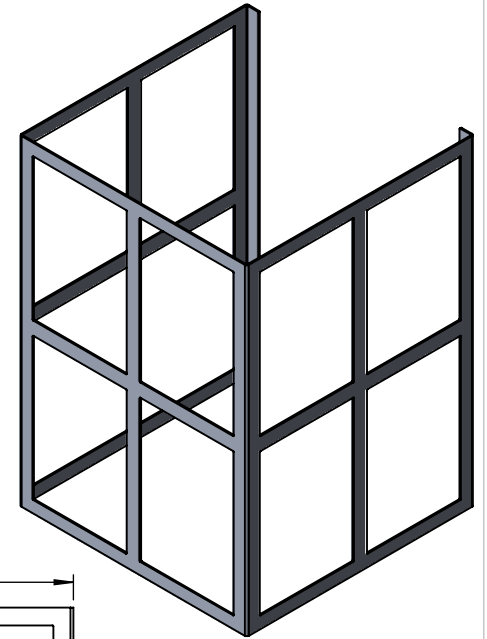
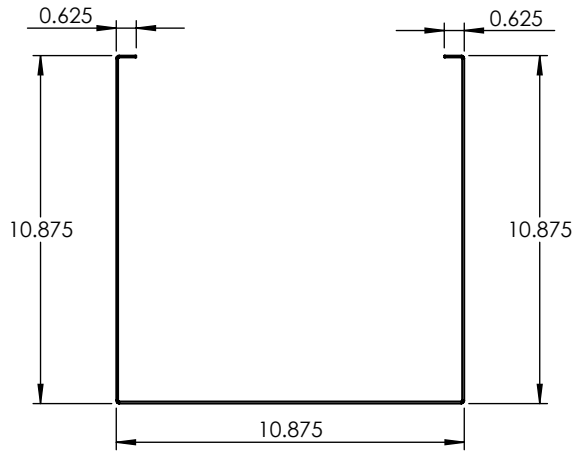

PROPRIETARY AND CONFIDENTIAL
 THE INFORMATION CONTAINED IN THIS DRAWING IS THE SOLE PROPERTY OF <INSERT COMPANY NAME HERE>. ANY REPRODUCTION IN PART OR AS A WHOLE WITHOUT THE WRITTEN PERMISSION OF <INSERT COMPANY NAME HERE> IS PROHIBITED.

		UNLESS OTHERWISE SPECIFIED:		NAME	DATE
		DIMENSIONS ARE IN INCHES	DRAWN		
		TOLERANCES:	CHECKED		
		FRACTIONAL ±	ENG APPR.		
		ANGULAR: MACH ± BEND ±	MFG APPR.		
		TWO PLACE DECIMAL ±	Q.A.		
		THREE PLACE DECIMAL ±	COMMENTS:		
		INTERPRET GEOMETRIC TOLERANCING PER:			
		MATERIAL			
		OLI RUBBER BRONZE POWDERCOAT			
		FINISH			
NEXT ASSY	USED ON				
APPLICATION	DO NOT SCALE DRAWING				

ALUMINUM 0.0635"

TITLE:

30609-11-CSTSTP-48"-DD

SIZE	DWG. NO.	REV
A		

SCALE: 1:6 WEIGHT: SHEET 8 OF 13

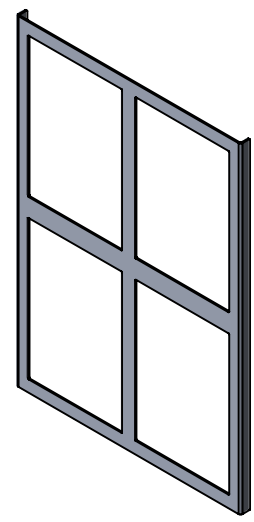
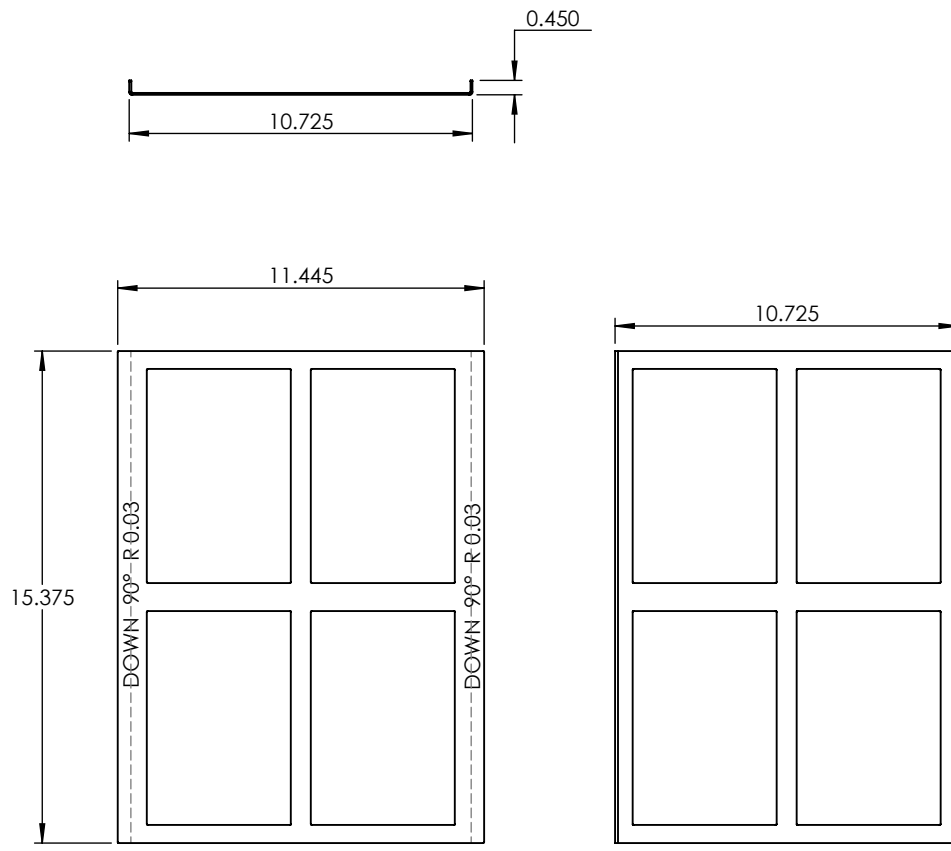

PROPRIETARY AND CONFIDENTIAL
 THE INFORMATION CONTAINED IN THIS DRAWING IS THE SOLE PROPERTY OF <INSERT COMPANY NAME HERE>. ANY REPRODUCTION IN PART OR AS A WHOLE WITHOUT THE WRITTEN PERMISSION OF <INSERT COMPANY NAME HERE> IS PROHIBITED.

		UNLESS OTHERWISE SPECIFIED:		NAME	DATE
		DIMENSIONS ARE IN INCHES	DRAWN		
		TOLERANCES:	CHECKED		
		FRACTIONAL ±	ENG APPR.		
		ANGULAR: MACH ± BEND ±	MFG APPR.		
		TWO PLACE DECIMAL ±	Q.A.		
		THREE PLACE DECIMAL ±	COMMENTS:		
		INTERPRET GEOMETRIC TOLERANCING PER:			
		MATERIAL			
		OLI RUBBER BRONZE POWDERCOAT			
		FINISH			
NEXT ASSY	USED ON				
APPLICATION		DO NOT SCALE DRAWING			

ALUMINUM 0.0635"		
TITLE:		
30609-11-CSTSTP-48"-DD		
SIZE	DWG. NO.	REV
A		
SCALE: 1:6	WEIGHT:	SHEET 9 OF 13

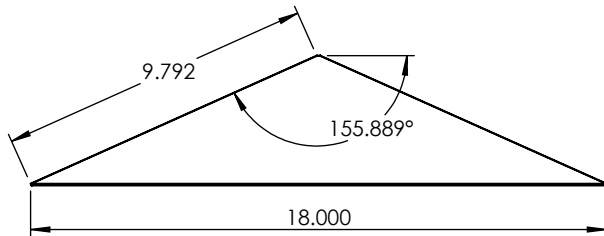
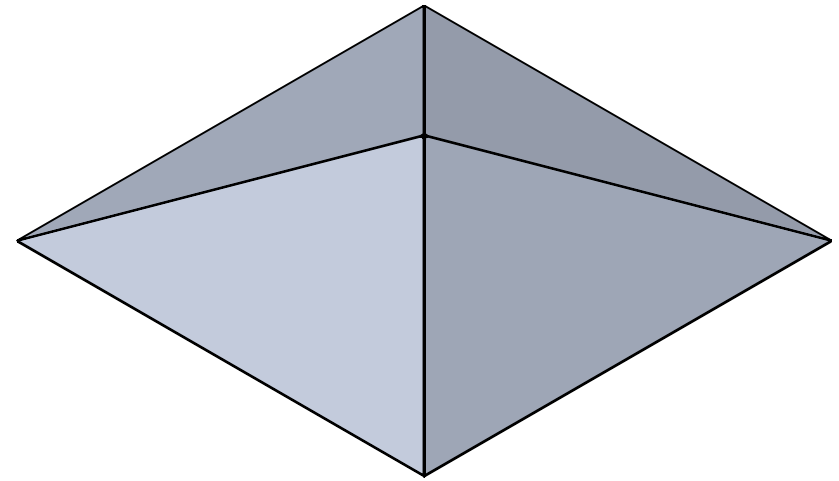
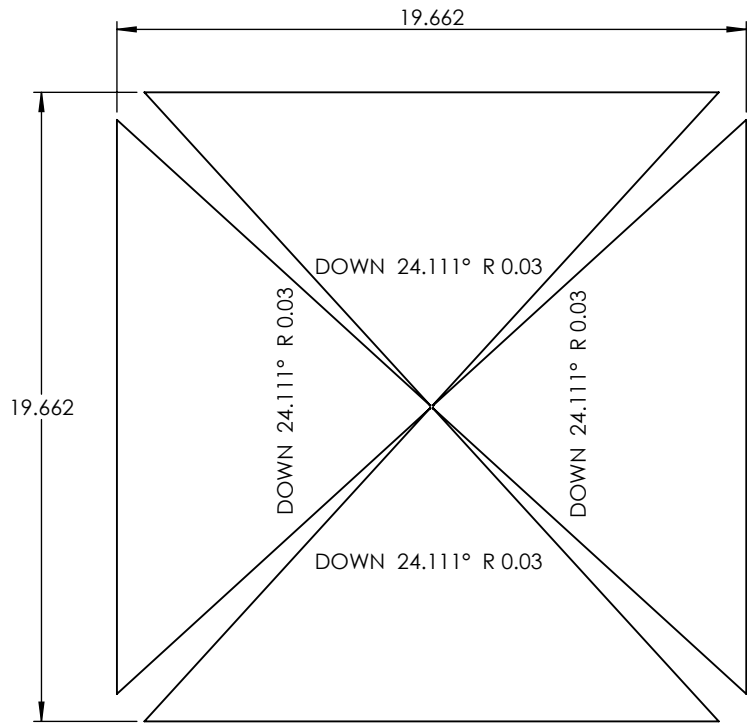

PROPRIETARY AND CONFIDENTIAL
 THE INFORMATION CONTAINED IN THIS DRAWING IS THE SOLE PROPERTY OF <INSERT COMPANY NAME HERE>. ANY REPRODUCTION IN PART OR AS A WHOLE WITHOUT THE WRITTEN PERMISSION OF <INSERT COMPANY NAME HERE> IS PROHIBITED.

		UNLESS OTHERWISE SPECIFIED:		NAME	DATE	ALUMINUM 0.0635"	
		DIMENSIONS ARE IN INCHES	DRAWN			TITLE:	
		TOLERANCES:	CHECKED			30609-11-CSTSTP-48"-DD	
		FRACTIONAL ±	ENG APPR.			SIZE	DWG. NO.
		ANGULAR: MACH ± BEND ±	MFG APPR.			A	REV
		TWO PLACE DECIMAL ±	Q.A.			SCALE: 1:6	WEIGHT:
		THREE PLACE DECIMAL ±	COMMENTS:				SHEET 10 OF 13
		INTERPRET GEOMETRIC TOLERANCING PER:					
		MATERIAL					
	NEXT ASSY	USED ON					
		FINISH					
	APPLICATION	DO NOT SCALE DRAWING					

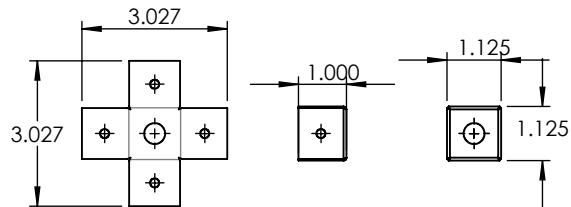
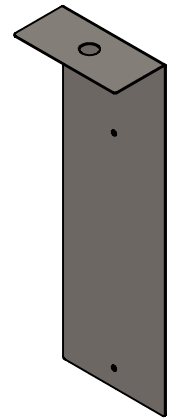
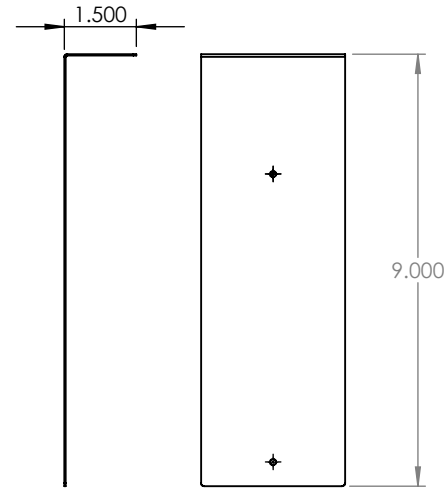
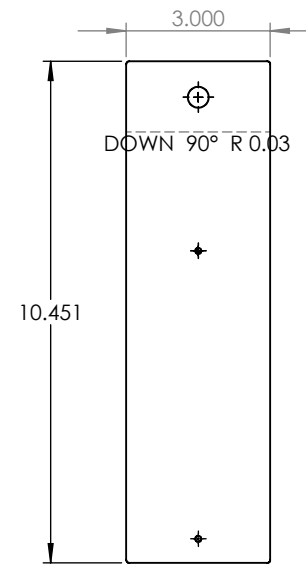
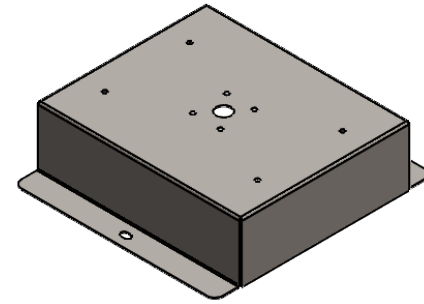
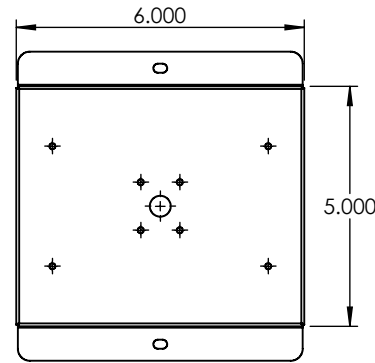
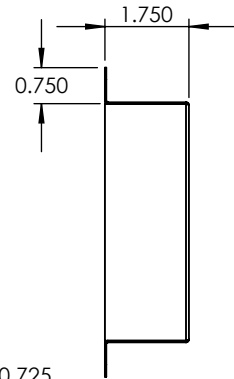
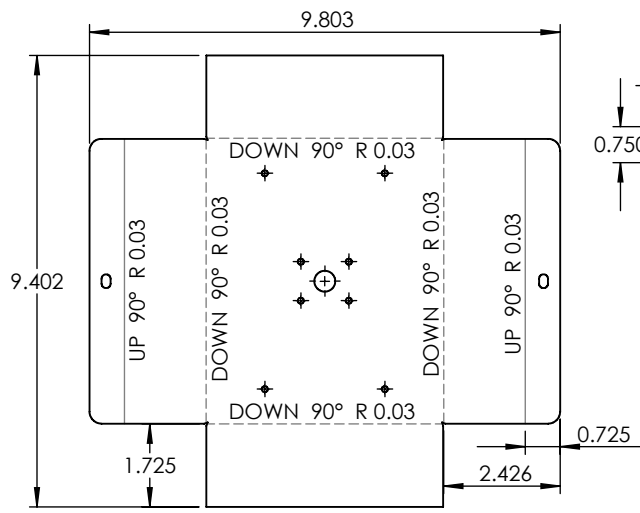

		UNLESS OTHERWISE SPECIFIED:	NAME	DATE	18 GAUGE	
		DIMENSIONS ARE IN INCHES	DRAWN		TITLE:	
		TOLERANCES:	CHECKED		30609-11-CSTSTP-48"-DD	
		FRACTIONAL ±	ENG APPR.		SIZE DWG. NO. REV	
		ANGULAR: MACH ± BEND ±	MFG APPR.		A	
		TWO PLACE DECIMAL ±	Q.A.		SCALE: 1:4 WEIGHT: SHEET 11 OF 13	
		THREE PLACE DECIMAL ±	COMMENTS:			
		INTERPRET GEOMETRIC TOLERANCING PER:				
		MATERIAL				
NEXT ASSY	USED ON	FINISH				
APPLICATION		DO NOT SCALE DRAWING				

5

4

3

2

1

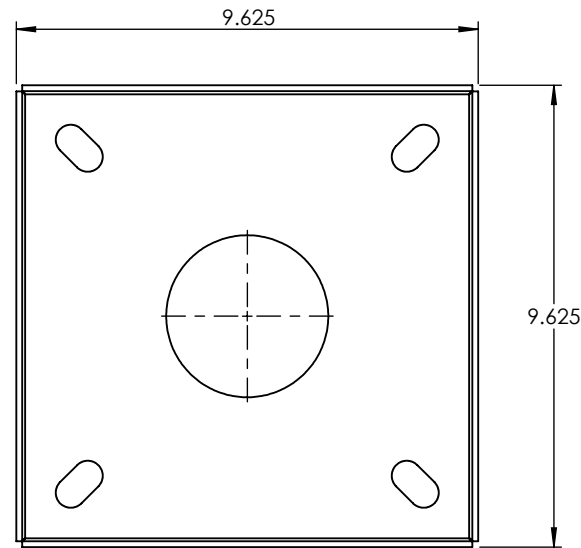
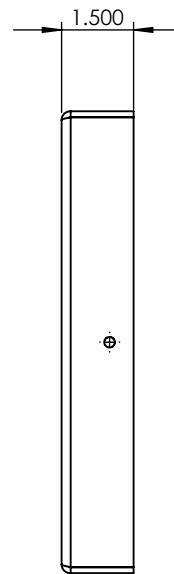
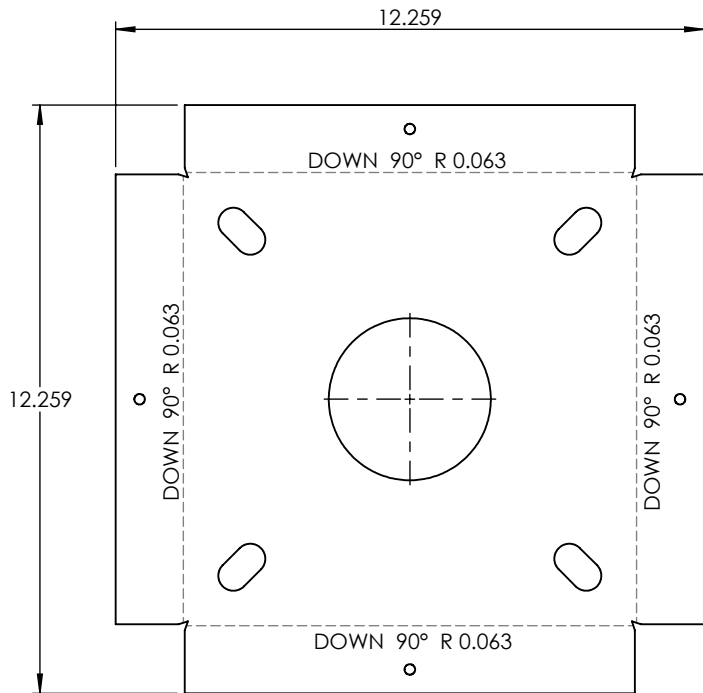
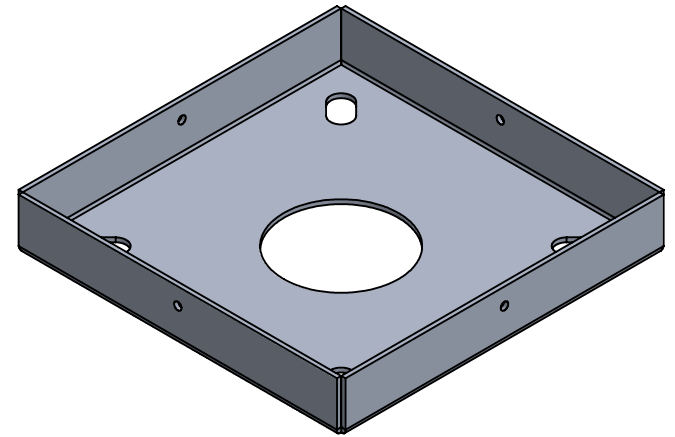

PROPRIETARY AND CONFIDENTIAL
 THE INFORMATION CONTAINED IN THIS DRAWING IS THE SOLE PROPERTY OF <INSERT COMPANY NAME HERE>. ANY REPRODUCTION IN PART OR AS A WHOLE WITHOUT THE WRITTEN PERMISSION OF <INSERT COMPANY NAME HERE> IS PROHIBITED.

		UNLESS OTHERWISE SPECIFIED:		NAME	DATE
		DIMENSIONS ARE IN INCHES			
		TOLERANCES:			
		FRACTIONAL ±		DRAWN	
		ANGULAR: MACH ± BEND ±		CHECKED	
		TWO PLACE DECIMAL ±		ENG APPR.	
		THREE PLACE DECIMAL ±		MFG APPR.	
		INTERPRET GEOMETRIC TOLERANCING PER:		Q.A.	
		MATERIAL		COMMENTS:	
		FINISH			
NEXT ASSY	USED ON				
APPLICATION		DO NOT SCALE DRAWING			

ALUMINUM 0.125" PLATE

TITLE:

30609-11-CSTSTP-48"-DD

SIZE	DWG. NO.	REV
A		

SCALE: 1:4 WEIGHT: SHEET 12 OF 13

