

UNLESS OTHERWISE SPECIFIED:

DIMENSIONS ARE IN INCHES  
 TOLERANCES:  
 FRACTIONAL  $\pm .003$   
 ANGULAR: MACH  $\pm .01$  BEND  $\pm$   
 TWO PLACE DECIMAL  $\pm$   
 THREE PLACE DECIMAL  $\pm .001$

INTERPRET GEOMETRIC  
 TOLERANCING PER:

MATERIAL

FINISH

ALL BEND RADIUS .030"

APPLICATION

DO NOT SCALE DRAWING

	NAME	DATE
DRAWN		
CHECKED		
ENG APPR.		
MFG APPR.		

Q.A.

COMMENTS:

TITLE:

EM712-TR-E2-12W-GR12-41K

SIZE	DWG. NO.	REV
<b>A</b>	TICKET 24238	

SCALE: 1:10	WEIGHT:	SHEET 1 OF 9



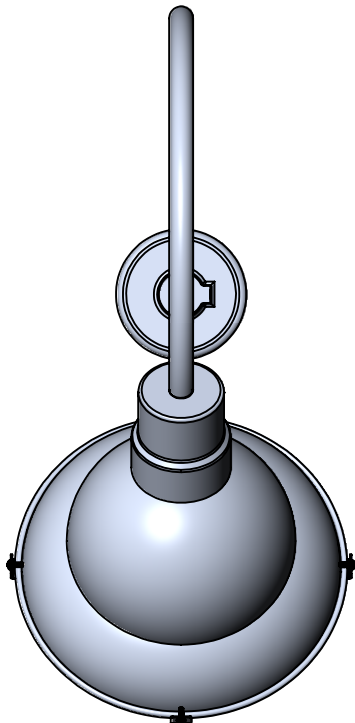
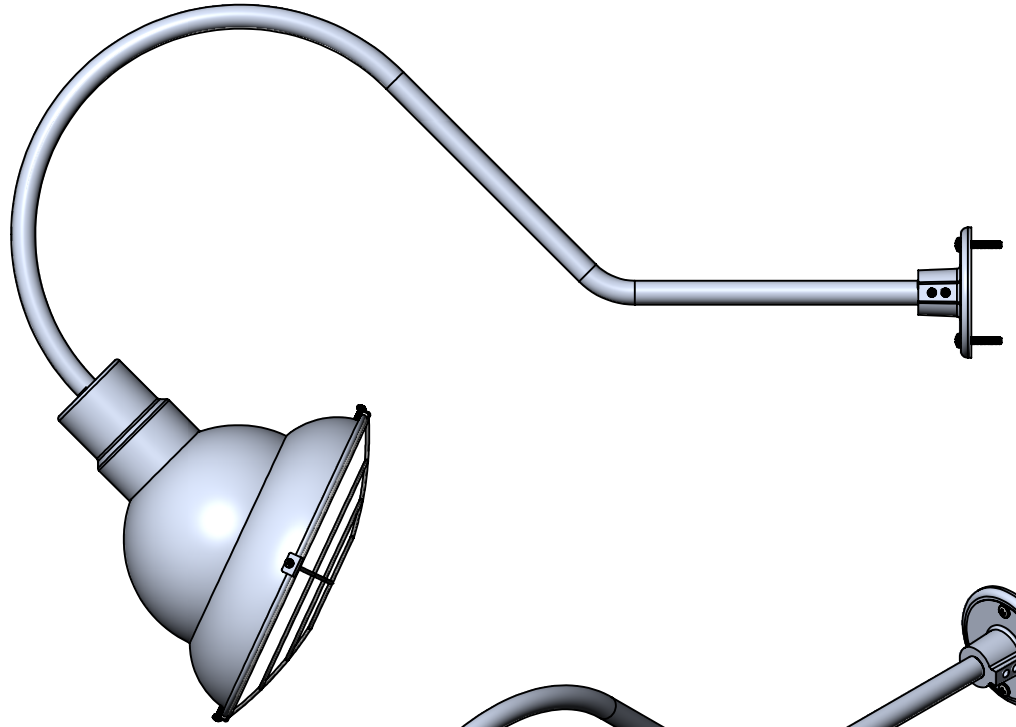
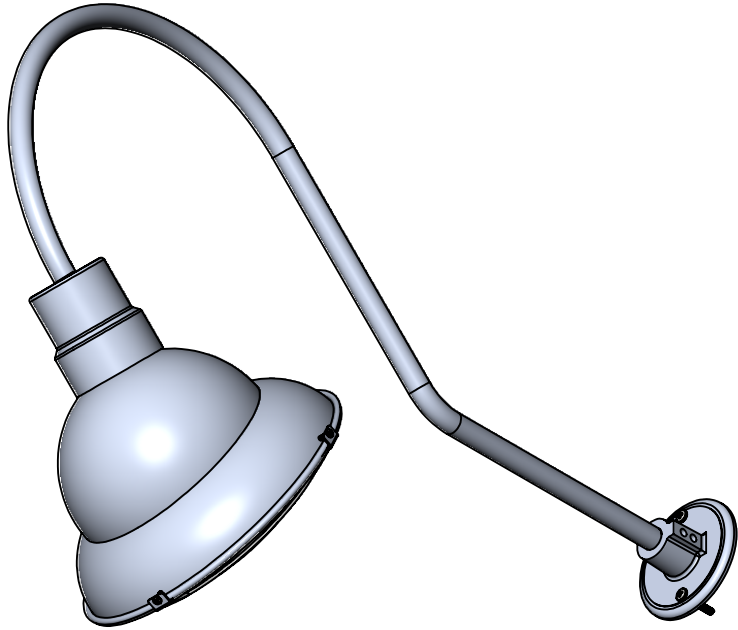

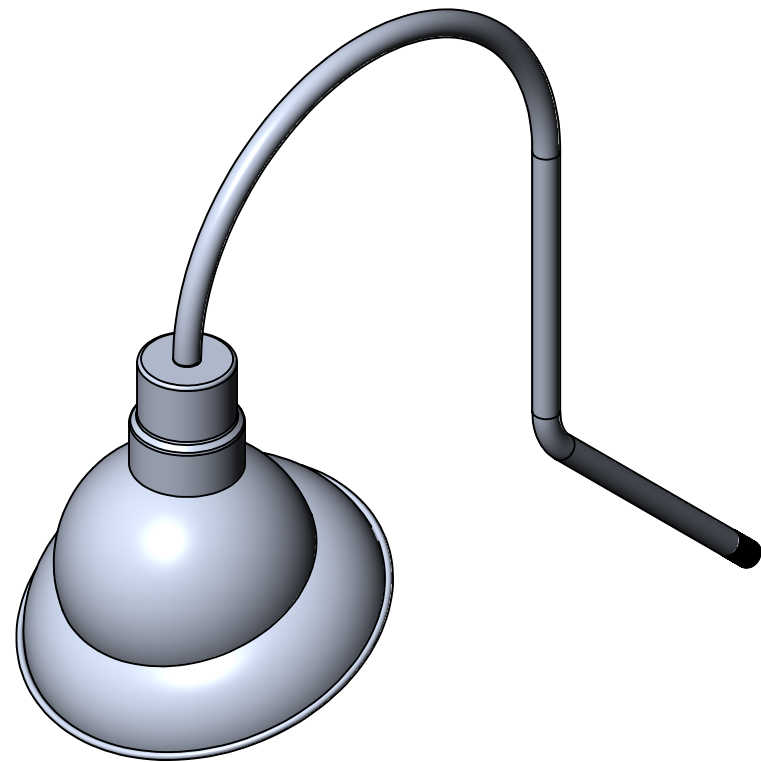
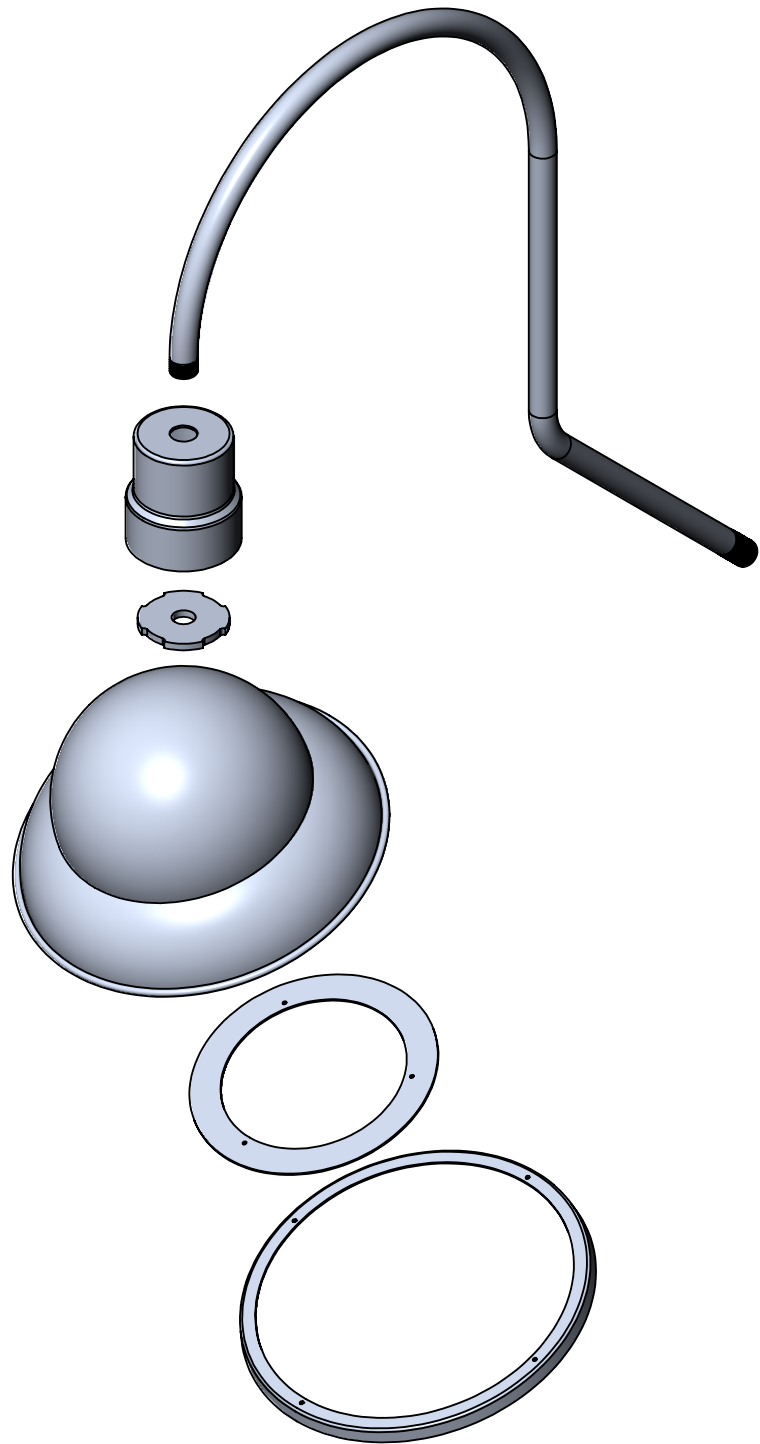

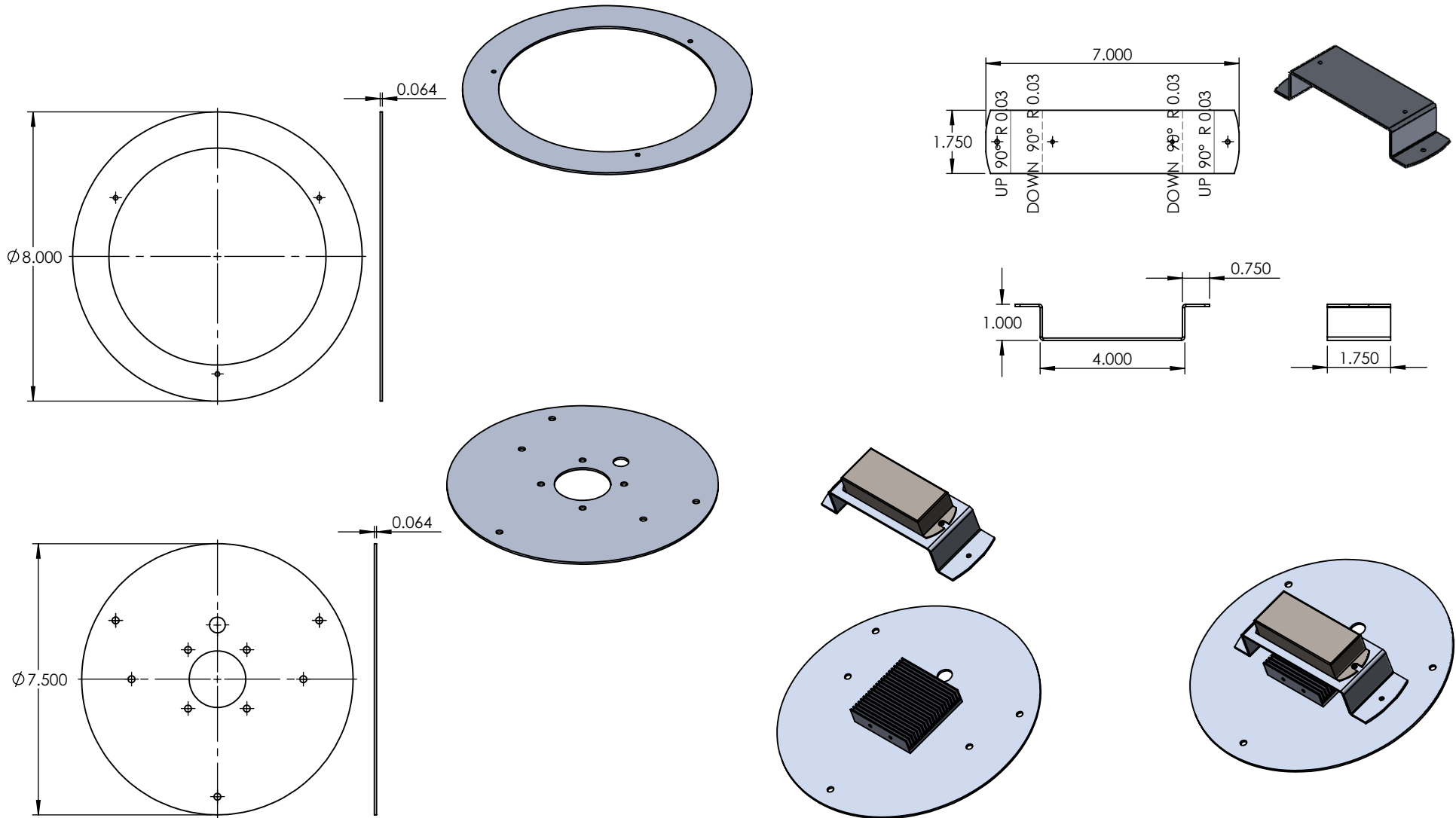

**PROPRIETARY AND CONFIDENTIAL**  
 THE INFORMATION CONTAINED IN THIS DRAWING IS THE SOLE PROPERTY OF <INSERT COMPANY NAME HERE>. ANY REPRODUCTION IN PART OR AS A WHOLE WITHOUT THE WRITTEN PERMISSION OF <INSERT COMPANY NAME HERE> IS PROHIBITED.

		UNLESS OTHERWISE SPECIFIED:		NAME	DATE
		DIMENSIONS ARE IN INCHES	DRAWN		
		TOLERANCES:	CHECKED		
		FRACTIONAL ±	ENG APPR.		
		ANGULAR: MACH ± BEND ±	MFG APPR.		
		TWO PLACE DECIMAL ±	Q.A.		
		THREE PLACE DECIMAL ±	COMMENTS:		
		INTERPRET GEOMETRIC TOLERANCING PER:			
		MATERIAL			
	NEXT ASSY	FINISH			
		USED ON			
	APPLICATION	DO NOT SCALE DRAWING			

ALUMINUM 0.0635"		
TITLE:		
EM712-TR-E2-12W-GR12-41K		
SIZE	DWG. NO.	REV
<b>A</b>		
SCALE: 1:4	WEIGHT:	SHEET 4 OF 9

5

4

3

2

1

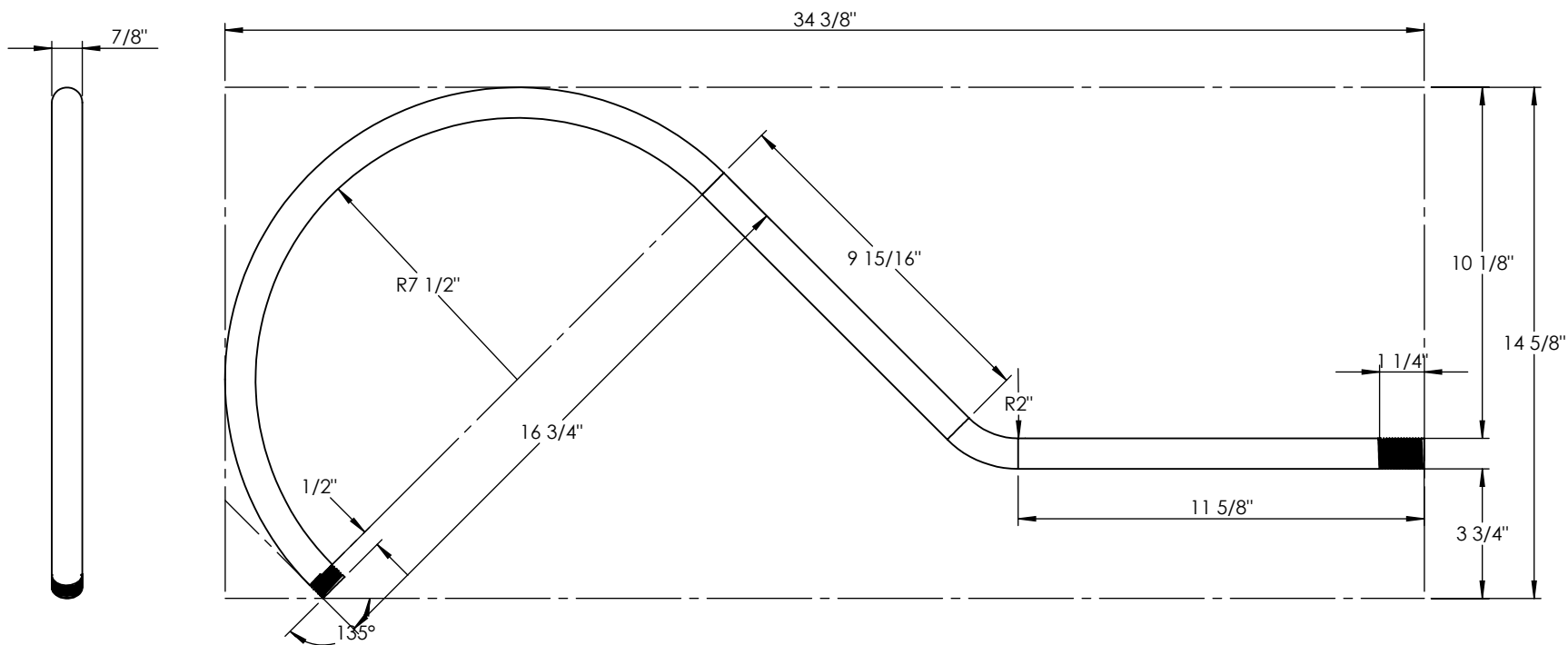
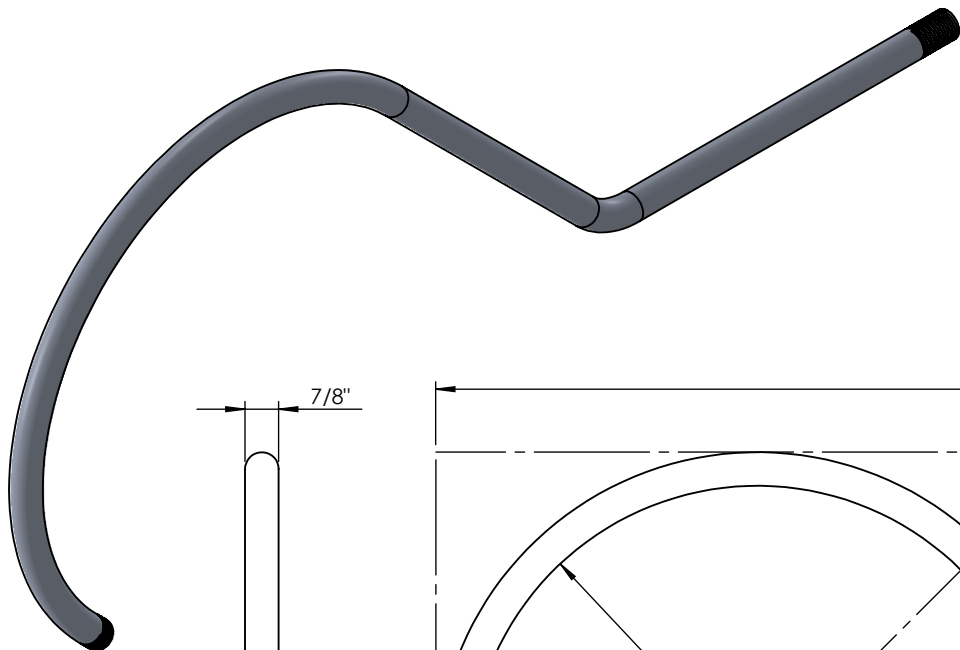

**PROPRIETARY AND CONFIDENTIAL**  
 THE INFORMATION CONTAINED IN THIS DRAWING IS THE SOLE PROPERTY OF <INSERT COMPANY NAME HERE>. ANY REPRODUCTION IN PART OR AS A WHOLE WITHOUT THE WRITTEN PERMISSION OF <INSERT COMPANY NAME HERE> IS PROHIBITED.

		UNLESS OTHERWISE SPECIFIED:	NAME	DATE
		DIMENSIONS ARE IN INCHES	DRAWN	
		TOLERANCES:	CHECKED	
		FRACTIONAL ±	ENG APPR.	
		ANGULAR: MACH ± BEND ±	MFG APPR.	
		TWO PLACE DECIMAL ±	Q.A.	
		THREE PLACE DECIMAL ±	COMMENTS:	
		INTERPRET GEOMETRIC TOLERANCING PER:		
		MATERIAL		
NEXT ASSY	USED ON	FINISH		
APPLICATION		DO NOT SCALE DRAWING		

**7/8" ALUMINUM TUBE**

TITLE:

**EM712-TR-E2-12W-GR12-41K**

SIZE	DWG. NO.	REV
<b>A</b>		

SCALE: 1:5 WEIGHT: SHEET 5 OF 9

ITEM NO.	PART NUMBER	DESCRIPTION	QTY.
1	EM712-TR-E2-12W-GR12-41K-SPUN SPHERE	SPUN ALUMINUM 0.080"	1

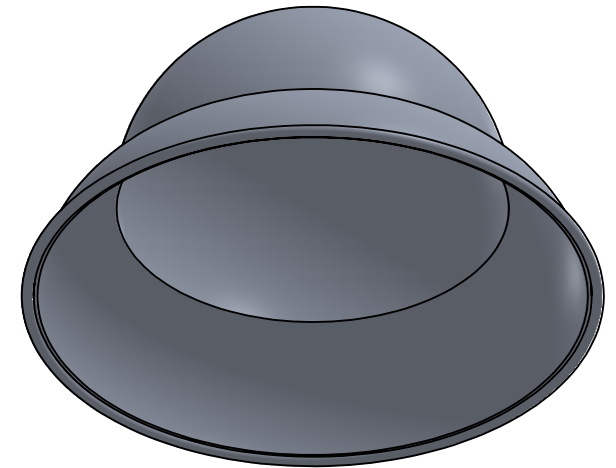
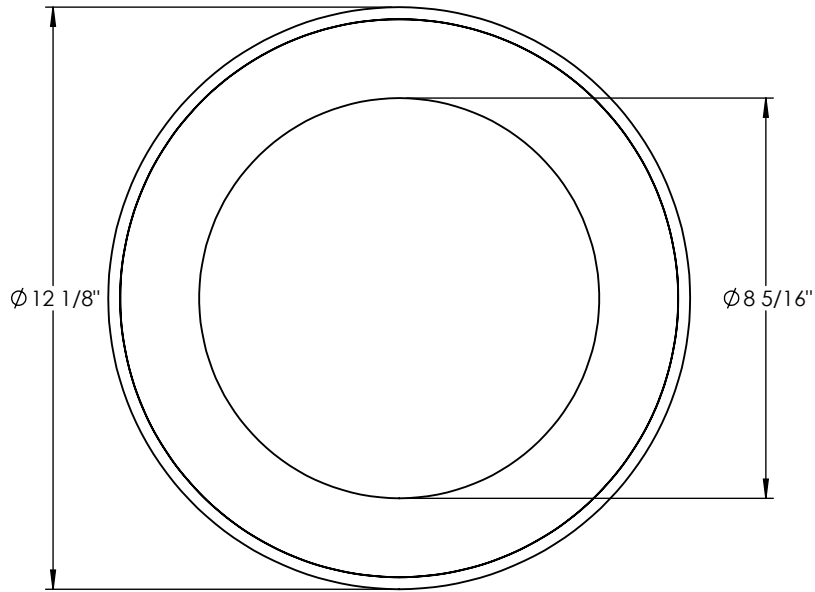
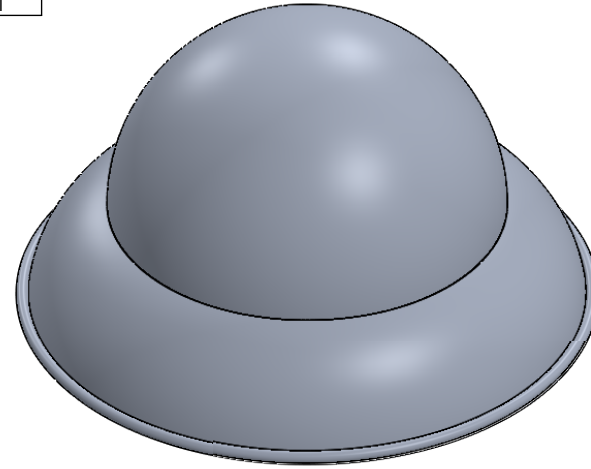
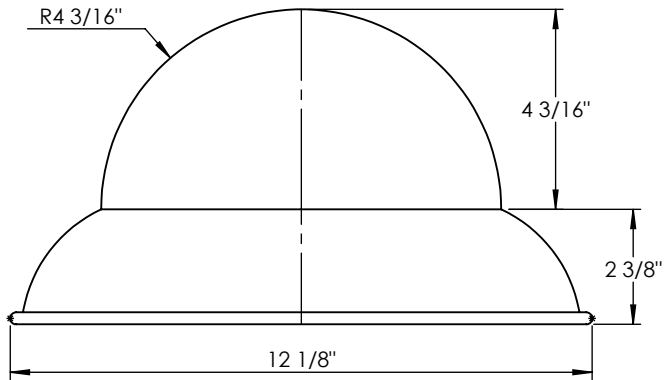

**PROPRIETARY AND CONFIDENTIAL**  
 THE INFORMATION CONTAINED IN THIS DRAWING IS THE SOLE PROPERTY OF <INSERT COMPANY NAME HERE>. ANY REPRODUCTION IN PART OR AS A WHOLE WITHOUT THE WRITTEN PERMISSION OF <INSERT COMPANY NAME HERE> IS PROHIBITED.

UNLESS OTHERWISE SPECIFIED:		NAME	DATE
DIMENSIONS ARE IN INCHES		DRAWN	
TOLERANCES:		CHECKED	
FRACTIONAL $\pm$		ENG APPR.	
ANGULAR: MACH $\pm$ BEND $\pm$		MFG APPR.	
TWO PLACE DECIMAL $\pm$		Q.A.	
THREE PLACE DECIMAL $\pm$		COMMENTS:	
INTERPRET GEOMETRIC TOLERANCING PER:			
MATERIAL			
FINISH			
NEXT ASSY	USED ON		
APPLICATION	DO NOT SCALE DRAWING		

SPUN ALUMINUM 0.080"

TITLE:

EM712-TR-E2-12W-GR12-41K

SIZE	DWG. NO.	REV
<b>A</b>		

SCALE: 1:4	WEIGHT:	SHEET 6 OF 9
------------	---------	--------------

ITEM NO.	PART NUMBER	DESCRIPTION	QTY.
1	EM712-TR-E2-12W-GR12-41K-SPUN CUP	SPUN ALUMINUM 0.080"	1

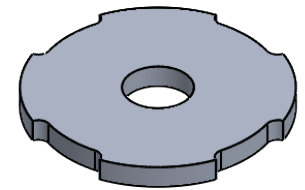
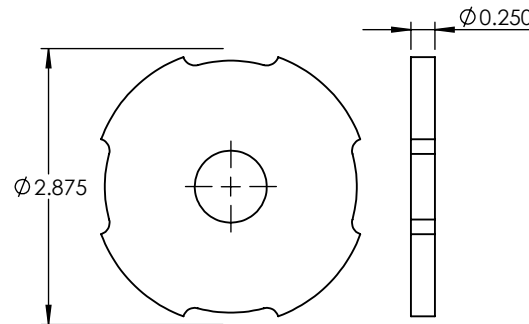
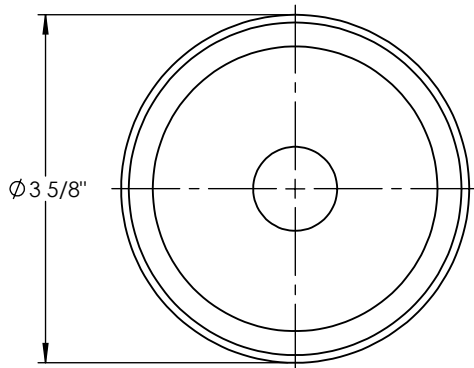
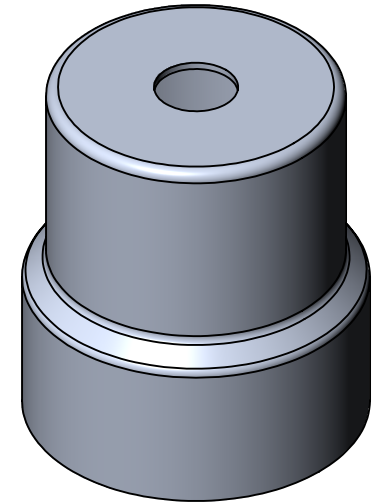
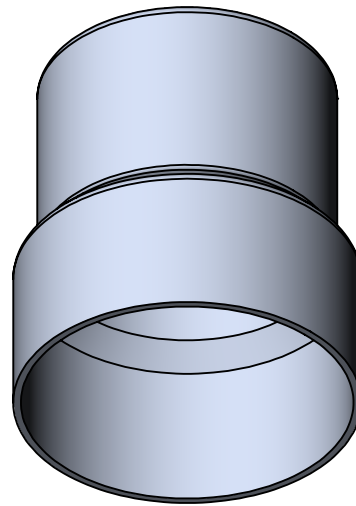
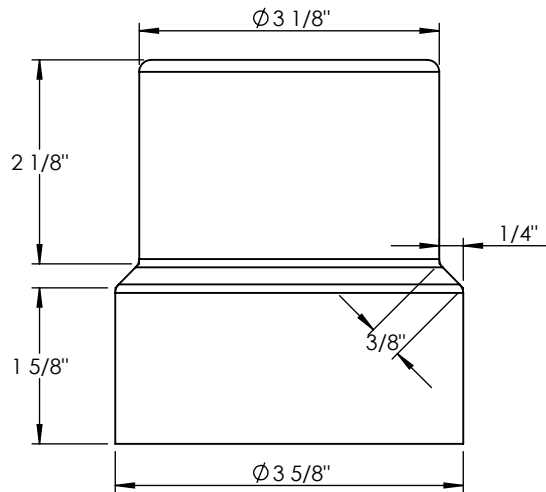

**PROPRIETARY AND CONFIDENTIAL**  
 THE INFORMATION CONTAINED IN THIS DRAWING IS THE SOLE PROPERTY OF <INSERT COMPANY NAME HERE>. ANY REPRODUCTION IN PART OR AS A WHOLE WITHOUT THE WRITTEN PERMISSION OF <INSERT COMPANY NAME HERE> IS PROHIBITED.

UNLESS OTHERWISE SPECIFIED:		NAME	DATE
DIMENSIONS ARE IN INCHES		DRAWN	
TOLERANCES:		CHECKED	
FRACTIONAL ±		ENG APPR.	
ANGULAR: MACH ± BEND ±		MFG APPR.	
TWO PLACE DECIMAL ±		Q.A.	
THREE PLACE DECIMAL ±		COMMENTS:	
INTERPRET GEOMETRIC TOLERANCING PER:			
MATERIAL			
FINISH			
NEXT ASSY	USED ON		
APPLICATION			
DO NOT SCALE DRAWING			

SPUN ALUMINUM 0.080"

TITLE:

EM712-TR-E2-12W-GR12-41K

SIZE  
**A**

DWG. NO.

REV

SCALE: 1:2

WEIGHT:

SHEET 7 OF 9

ITEM NO.	PART NUMBER	DESCRIPTION	QTY.
1	EM712-TR-E2-12W-GR12-41K-SPUN DOOR BRACKET	SPUN ALUMINUM 0.080"	1

ITEM NO.	PART NUMBER	DESCRIPTION	QTY.
1	EM712-TR-E2-12W-GR12-41K-SPUN DOOR	SPUN ALUMINUM 0.080"	1

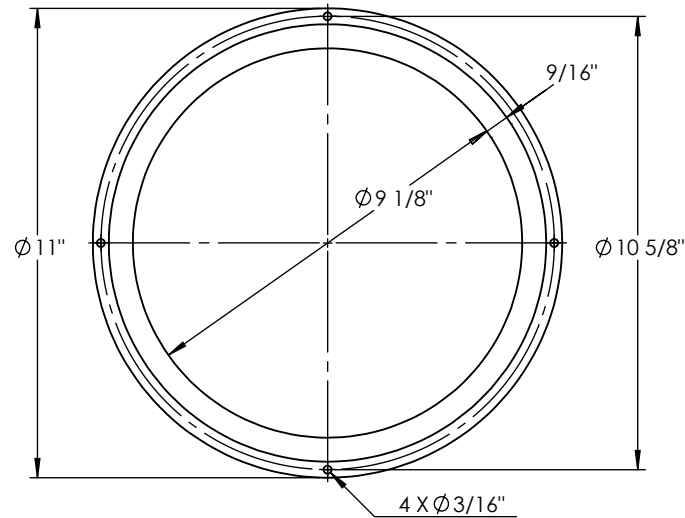
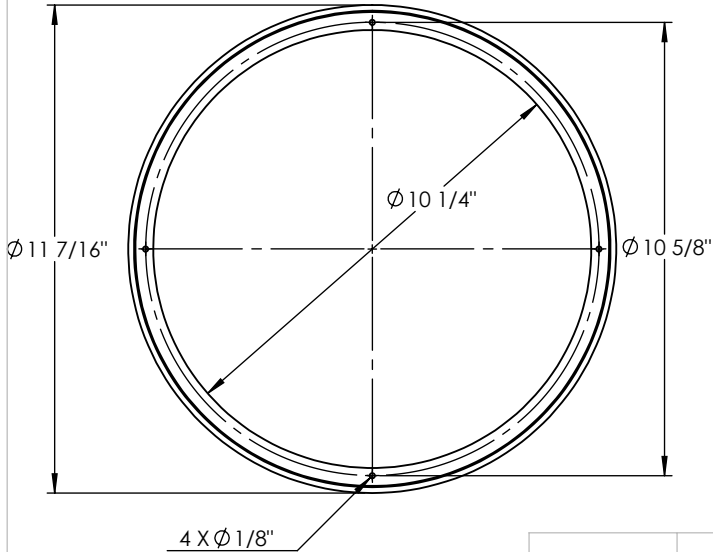
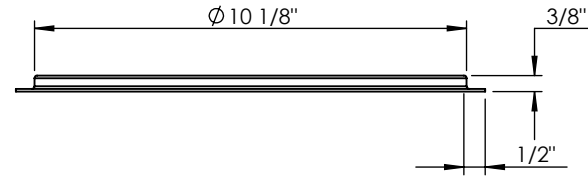
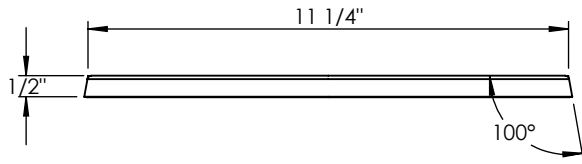
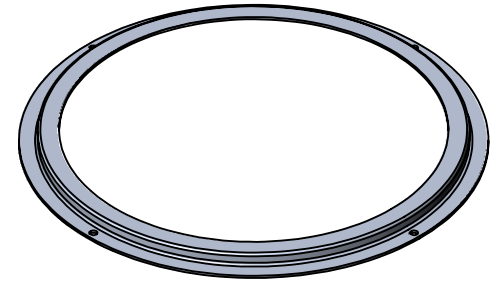
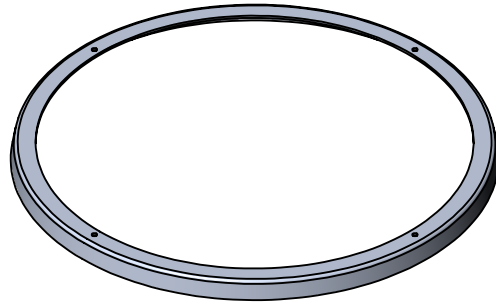

**PROPRIETARY AND CONFIDENTIAL**  
 THE INFORMATION CONTAINED IN THIS DRAWING IS THE SOLE PROPERTY OF <INSERT COMPANY NAME HERE>. ANY REPRODUCTION IN PART OR AS A WHOLE WITHOUT THE WRITTEN PERMISSION OF <INSERT COMPANY NAME HERE> IS PROHIBITED.

UNLESS OTHERWISE SPECIFIED:		NAME	DATE
DIMENSIONS ARE IN INCHES		DRAWN	
TOLERANCES:		CHECKED	
FRACTIONAL ±		ENG APPR.	
ANGULAR: MACH ± BEND ±		MFG APPR.	
TWO PLACE DECIMAL ±		Q.A.	
THREE PLACE DECIMAL ±		COMMENTS:	
INTERPRET GEOMETRIC TOLERANCING PER:			
MATERIAL			
FINISH			
NEXT ASSY	USED ON		
APPLICATION	DO NOT SCALE DRAWING		

SPUN ALUMINUM 0.080"		
TITLE:		
EM712-TR-E2-12W-GR12-41K		
SIZE	DWG. NO.	REV
<b>A</b>		
SCALE: 1:4.5	WEIGHT:	SHEET 8 OF 9



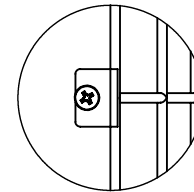
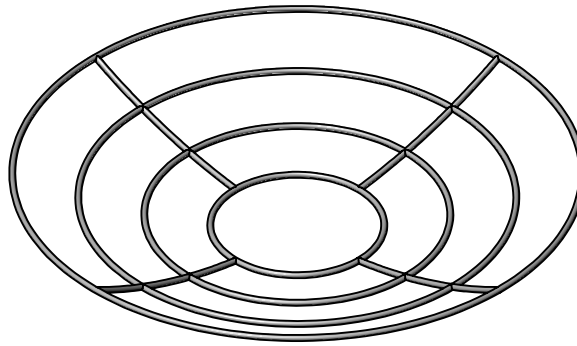
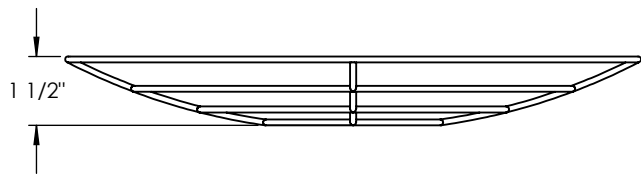

DETAIL C  
SCALE 2 : 5

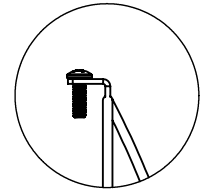

DETAIL A  
SCALE 2 : 5

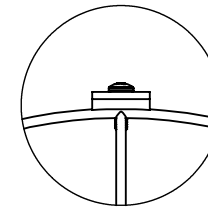

DETAIL B  
SCALE 2 : 5

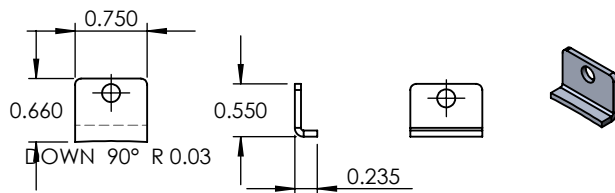
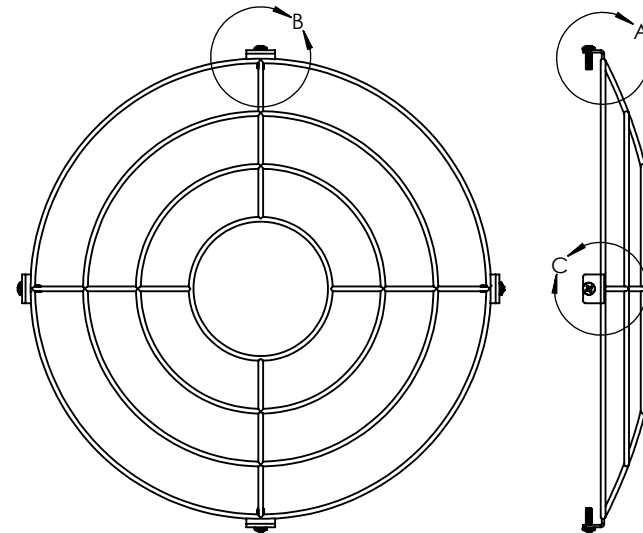
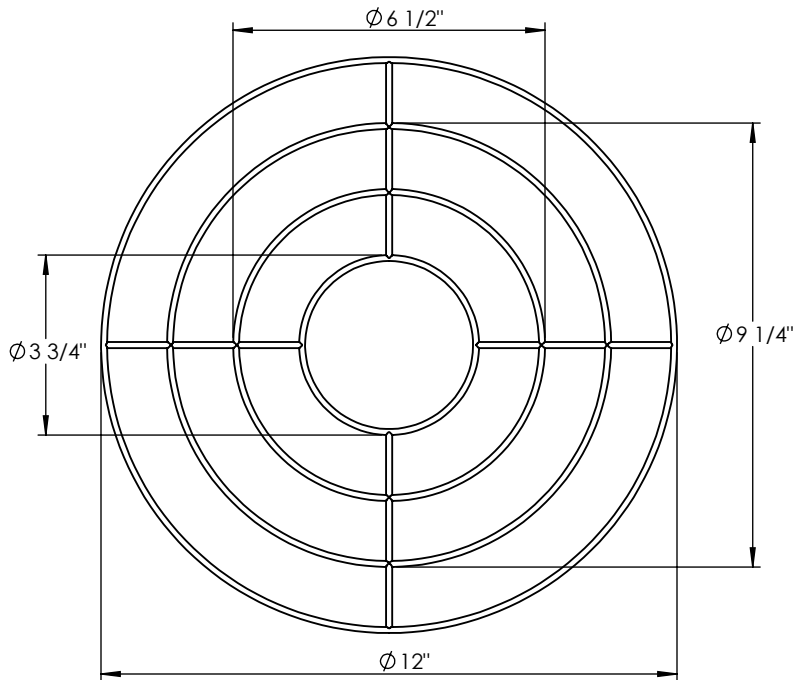

UNLESS OTHERWISE SPECIFIED:

DIMENSIONS ARE IN INCHES  
TOLERANCES:  
FRACTIONAL ±  
ANGULAR: MACH ± BEND ±  
TWO PLACE DECIMAL ±  
THREE PLACE DECIMAL ±

INTERPRET GEOMETRIC  
TOLERANCING PER:

MATERIAL

FINISH

DO NOT SCALE DRAWING

NAME

DATE

DRAWN

CHECKED

ENG APPR.

MFG APPR.

Q.A.

COMMENTS:

ALUMINUM 0.250" WIRE

TITLE:

EM712-TR-E2-12W-GR12-41K

SIZE  
**A**

DWG. NO.

REV

SCALE: 1:4

WEIGHT:

SHEET 9 OF 9

**PROPRIETARY AND CONFIDENTIAL**  
THE INFORMATION CONTAINED IN THIS  
DRAWING IS THE SOLE PROPERTY OF  
<INSERT COMPANY NAME HERE>. ANY  
REPRODUCTION IN PART OR AS A WHOLE  
WITHOUT THE WRITTEN PERMISSION OF  
<INSERT COMPANY NAME HERE> IS  
PROHIBITED.

NEXT ASSY

USED ON

APPLICATION

5

4

3

2

1