

ITEM NO.	PART NUMBER	DESCRIPTION	QTY.	CUT
1	ANGDN-8W-12X8-9WF-WET-41K-FRAME	22 GAUGE	1	
2	ANGDN-8W-12X8-9WF-WET-41K-TOP FRAME TABS	22 GAUGE	2	
3	ANGDN-8W-12X8-9WF-WET-41K-BOTTOM FRAME TABS	22 GAUGE	2	
4	ANGDN-8W-12X8-9WF-WET-41K-SOLID CAPS	22 GAUGE	2	
5	ANGDN-8W-12X8-9WF-WET-41K-BACKPLATE	22 GAUGE	1	
6	ANGDN-8W-12X8-9WF-WET-41K-FIREPLATE	22 GAUGE	1	
7	ANGDN-8W-12X8-9WF-WET-41K-ACRYLIC	ACRYLIC	1	
8	EspenTECH_120277V_SKU808076	DRIVER	1	
9	AlfAILED_PN1011_RevB	LED	2	

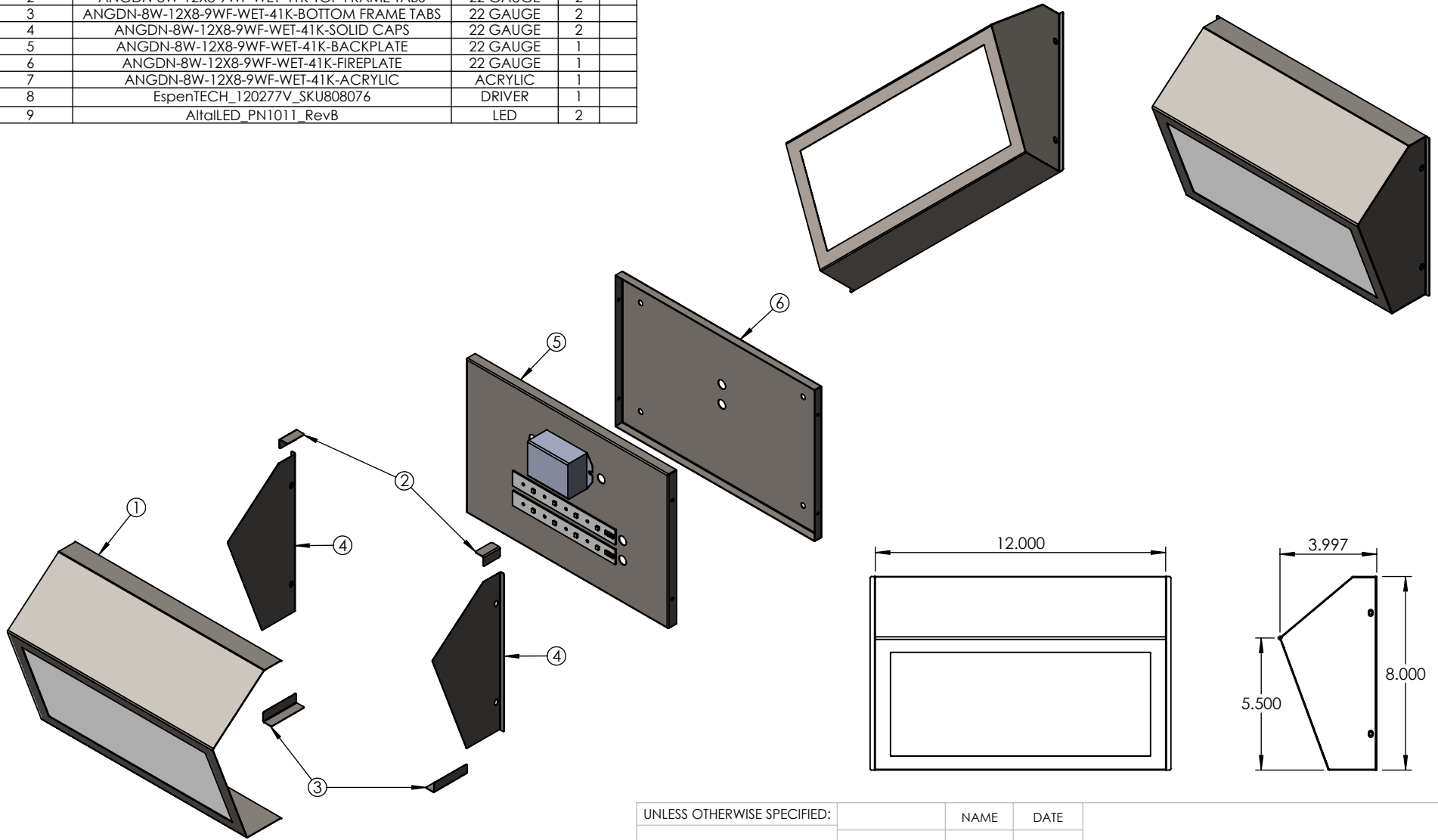

ALL BEND RADIUS .030"

APPLICATION

DO NOT SCALE DRAWING

UNLESS OTHERWISE SPECIFIED:

DIMENSIONS ARE IN INCHES
 TOLERANCES:
 FRACTIONAL $\pm .003$
 ANGULAR: MACH $\pm .01$ BEND \pm
 TWO PLACE DECIMAL \pm
 THREE PLACE DECIMAL $\pm .001$

INTERPRET GEOMETRIC
 TOLERANCING PER:

MATERIAL

FINISH

NAME

DATE

DRAWN

CHECKED

ENG APPR.

MFG APPR.

Q.A.

COMMENTS:

TITLE:

ANGDN-8W-12X8-9WF-WET-41K

SIZE DWG. NO.

A TICKET 24239

REV

SCALE: 1:6

WEIGHT:

SHEET 1 OF 5

5

4

3

2

1

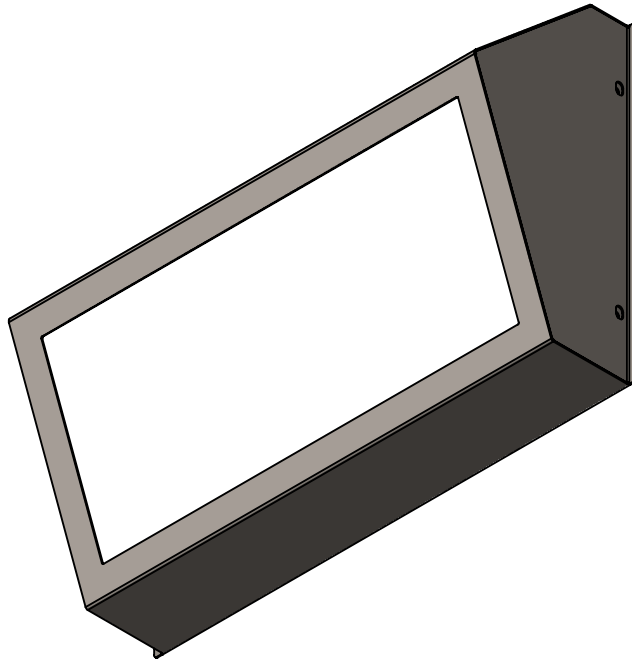
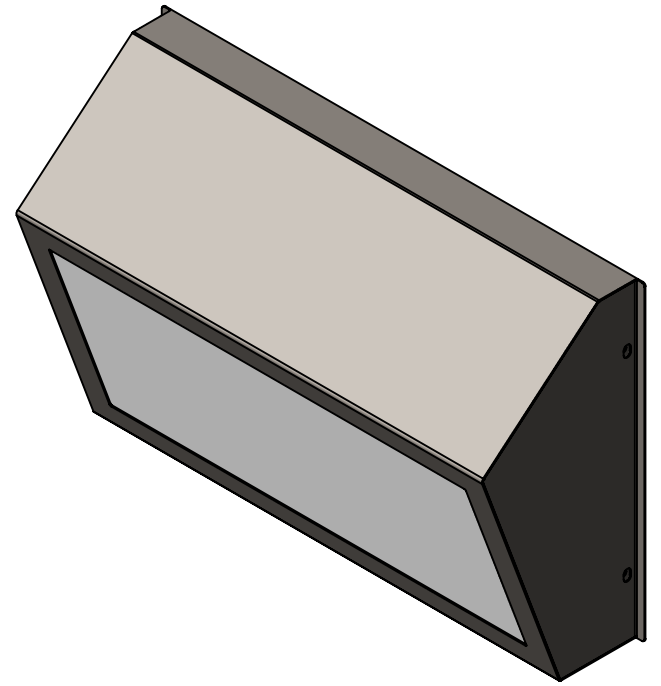
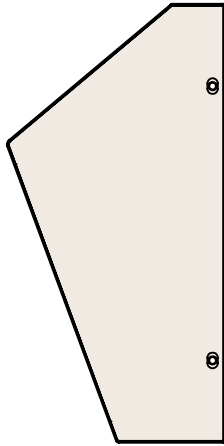
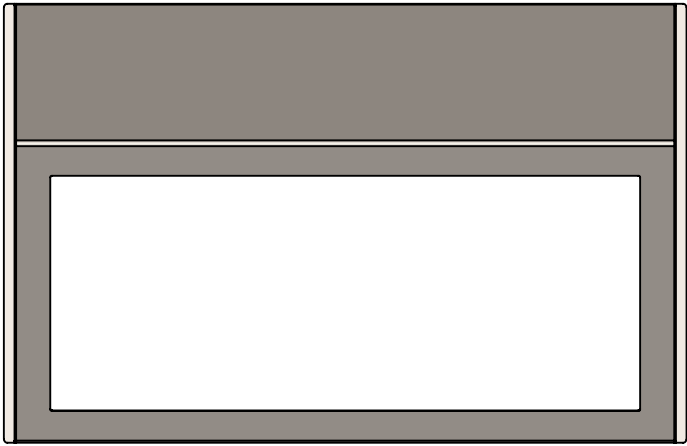

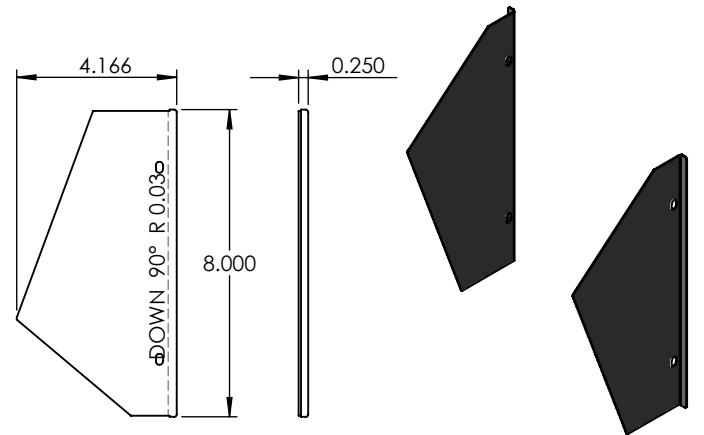
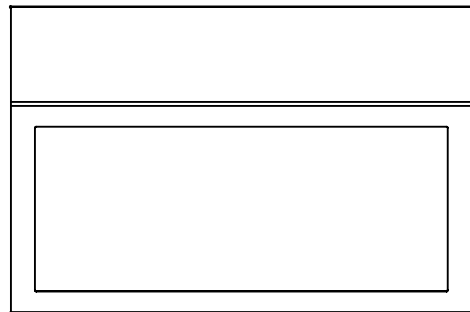
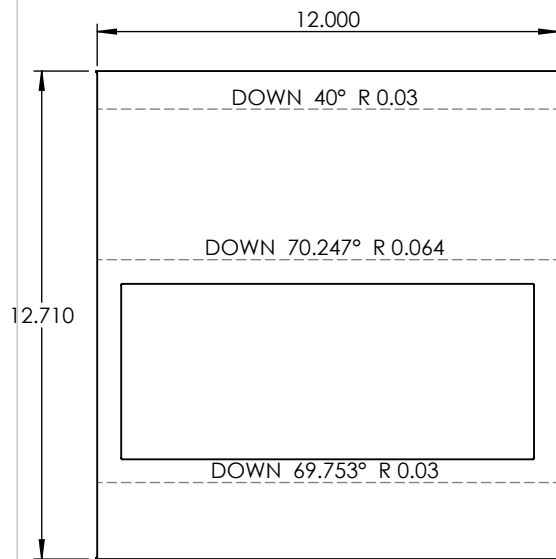
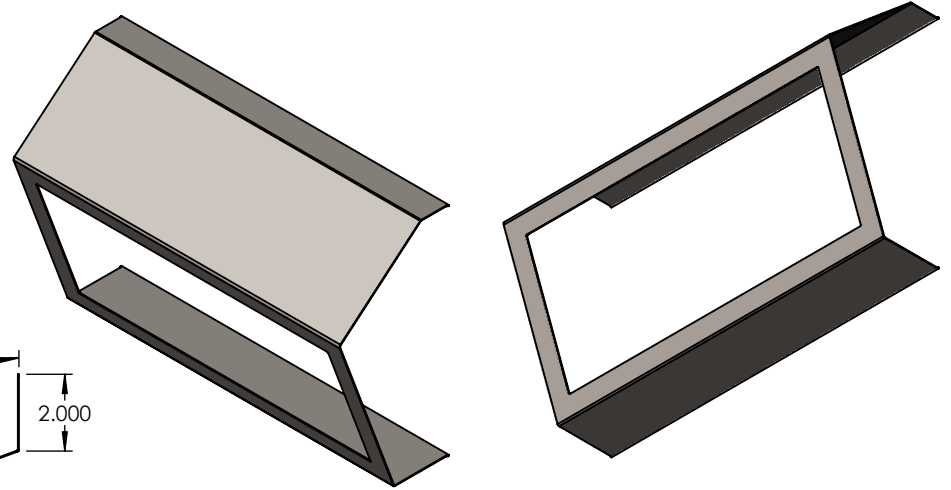
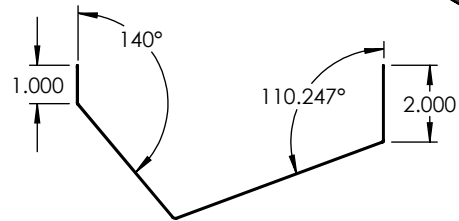
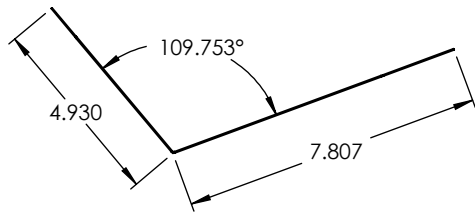

PROPRIETARY AND CONFIDENTIAL
 THE INFORMATION CONTAINED IN THIS DRAWING IS THE SOLE PROPERTY OF <INSERT COMPANY NAME HERE>. ANY REPRODUCTION IN PART OR AS A WHOLE WITHOUT THE WRITTEN PERMISSION OF <INSERT COMPANY NAME HERE> IS PROHIBITED.

		UNLESS OTHERWISE SPECIFIED:	NAME	DATE
		DIMENSIONS ARE IN INCHES	DRAWN	
		TOLERANCES:	CHECKED	
		FRACTIONAL ±	ENG APPR.	
		ANGULAR: MACH ± BEND ±	MFG APPR.	
		TWO PLACE DECIMAL ±	Q.A.	
		THREE PLACE DECIMAL ±	COMMENTS:	
		INTERPRET GEOMETRIC TOLERANCING PER:		
		MATERIAL		
NEXT ASSY	USED ON	FINISH		
APPLICATION		DO NOT SCALE DRAWING		

22 GAUGE		
TITLE:		
ANGDN-8W-12X8-9WF-WET-41K		
SIZE	DWG. NO.	REV
A		
SCALE: 1:5	WEIGHT:	SHEET 3 OF 5

5

4

3

2

1

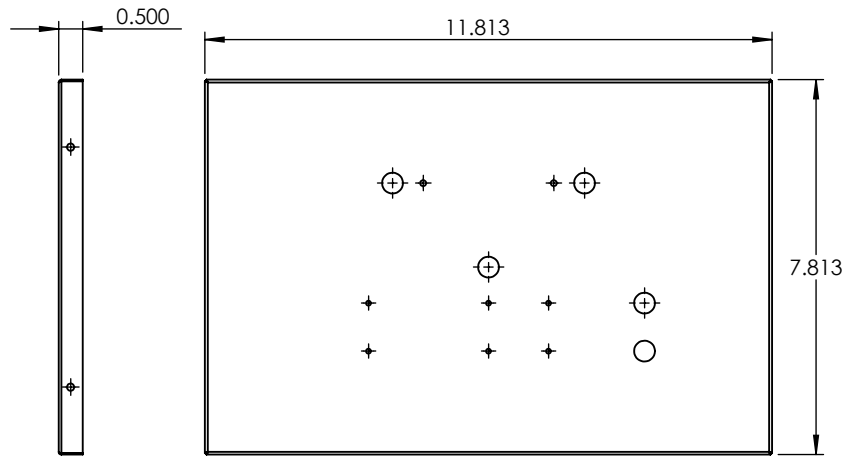
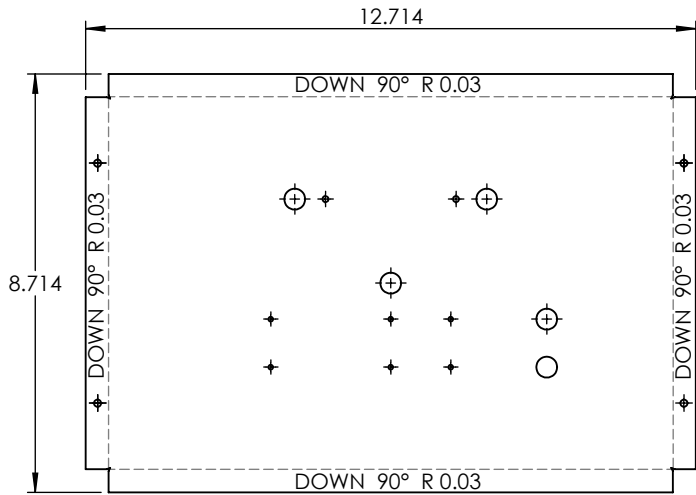
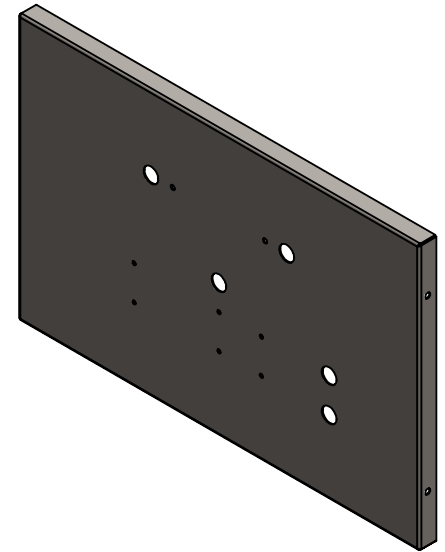

PROPRIETARY AND CONFIDENTIAL
 THE INFORMATION CONTAINED IN THIS DRAWING IS THE SOLE PROPERTY OF <INSERT COMPANY NAME HERE>. ANY REPRODUCTION IN PART OR AS A WHOLE WITHOUT THE WRITTEN PERMISSION OF <INSERT COMPANY NAME HERE> IS PROHIBITED.

		UNLESS OTHERWISE SPECIFIED:		NAME	DATE	+ 22 GAUGE	
		DIMENSIONS ARE IN INCHES					TITLE: ANGDN-8W-12X8-9WF-WET-41K
		TOLERANCES:					
		FRACTIONAL ±					
		ANGULAR: MACH ± BEND ±					
		TWO PLACE DECIMAL ±				SIZE DWG. NO. REV	
		THREE PLACE DECIMAL ±					
		INTERPRET GEOMETRIC TOLERANCING PER:				SCALE: 1:4 WEIGHT: SHEET 4 OF 5	
		MATERIAL					
		FINISH					
NEXT ASSY	USED ON						
APPLICATION		DO NOT SCALE DRAWING					

5

4

3

2

1

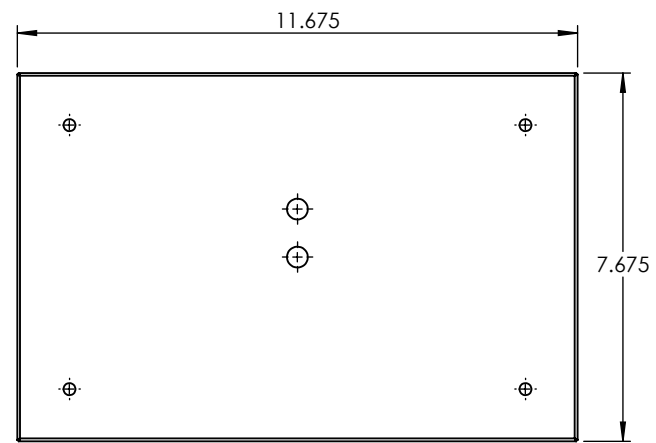
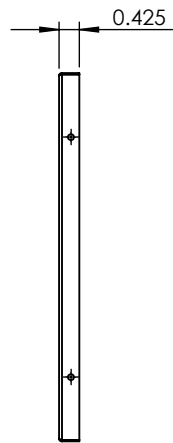
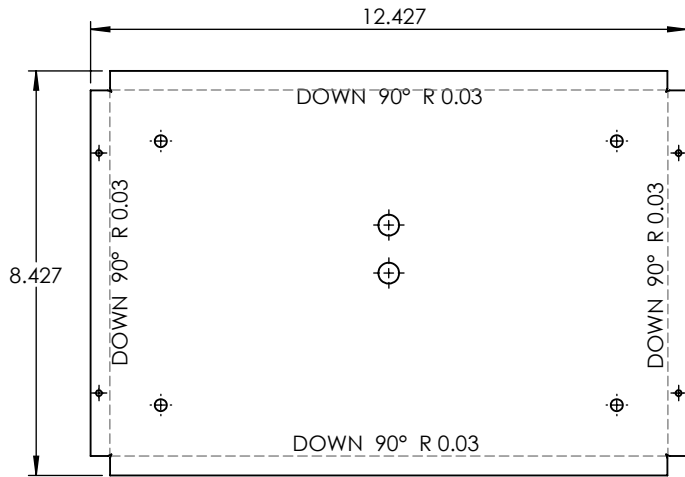
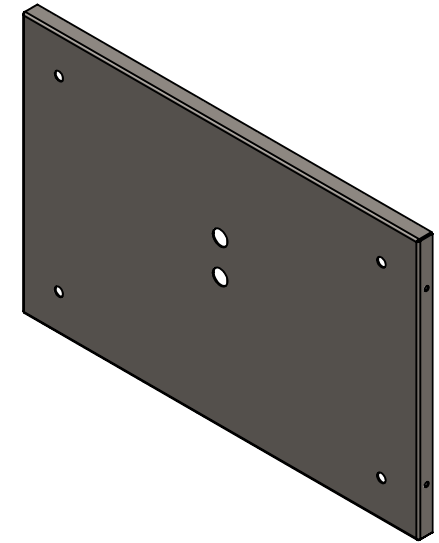
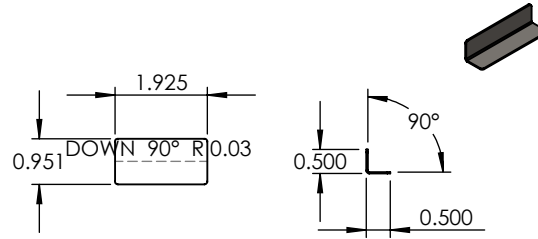
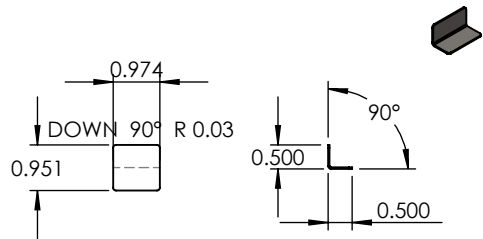

PROPRIETARY AND CONFIDENTIAL
 THE INFORMATION CONTAINED IN THIS DRAWING IS THE SOLE PROPERTY OF <INSERT COMPANY NAME HERE>. ANY REPRODUCTION IN PART OR AS A WHOLE WITHOUT THE WRITTEN PERMISSION OF <INSERT COMPANY NAME HERE> IS PROHIBITED.

		UNLESS OTHERWISE SPECIFIED:		NAME	DATE
		DIMENSIONS ARE IN INCHES	DRAWN		
		TOLERANCES:	CHECKED		
		FRACTIONAL ±	ENG APPR.		
		ANGULAR: MACH ± BEND ±	MFG APPR.		
		TWO PLACE DECIMAL ±	Q.A.		
		THREE PLACE DECIMAL ±	COMMENTS:		
		INTERPRET GEOMETRIC TOLERANCING PER:			
		MATERIAL			
		FINISH			
NEXT ASSY	USED ON				
APPLICATION	DO NOT SCALE DRAWING				

22 GAUGE		
TITLE:		
ANGDN-8W-12X8-9WF-WET-41K		
SIZE	DWG. NO.	REV
A		
SCALE: 1:4	WEIGHT:	SHEET 5 OF 5