

UNLESS OTHERWISE SPECIFIED:		NAME	DATE	FIXTURE HEAD		
DIMENSIONS ARE IN INCHES TOLERANCES: FRACTIONAL ± .003 ANGULAR: MACH ± .01 BEND ± TWO PLACE DECIMAL ± THREE PLACE DECIMAL ±.001		DRAWN				TITLE:
INTERPRET GEOMETRIC TOLERANCING PER:		CHECKED		PAL4320LS-MBK-WF-30K		
MATERIAL		ENG APPR.				
FINISH		MFG APPR.		SIZE	DWG. NO.	REV
ALL BEND RADIUS .030"		Q.A.		A TICKET 24417		
APPLICATION	DO NOT SCALE DRAWING	COMMENTS:		SCALE: 1:8	WEIGHT:	SHEET 1 OF 13



EVERGREEN LIGHTING

5

4

3

2

1

ITEM NO.	PART NUMBER	DESCRIPTION	QTY.	CUT
1	PAL4320LS-MBK-WF-30K-TOP SPUN BOWL	SPUN 22 GAUGE	1	
2	PAL4320LS-MBK-WF-30K-TOP SPUN ACCENTS	SPUN 22 GAUGE	1	
3	PAL4320LS-MBK-WF-30K-TOP SQUARE	22 GAUGE	1	
4	PAL4320LS-MBK-WF-30K-FRAME TOP BEND	22 GAUGE	4	
5	PAL4320LS-MBK-WF-30K-FRAME TABS	22 GAUGE	4	
6	PAL4320LS-MBK-WF-30K-FRAME BOTTOM BEND	22 GAUGE	4	
7	PAL4320LS-MBK-WF-30K-DOOR	22 GAUGE	1	
8	PAL4320LS-MBK-WF-30K-BRACKET TABS	22 GAUGE	2	
9	PAL4320LS-MBK-WF-30K-LED BRACKET	22 GAUGE	1	
10	PAL4320LS-MBK-WF-30K-BOTTOM CAP	18 GAUGE	1	
11	PAL4320LS-MBK-WF-30K-ACRYLIC	ACRYLIC	4	
12	POST FITTER	3" STEEL POST FITTER	1	
13	Altal_LED_PN1019_SHIM PLATE	ALUMINUM 0.125" PLATE	2	
14	KTLD-25-UV-700-VDIM-LA1	DRIVER	1	
15	Altal_LED_PN1019_RevC	LED	2	

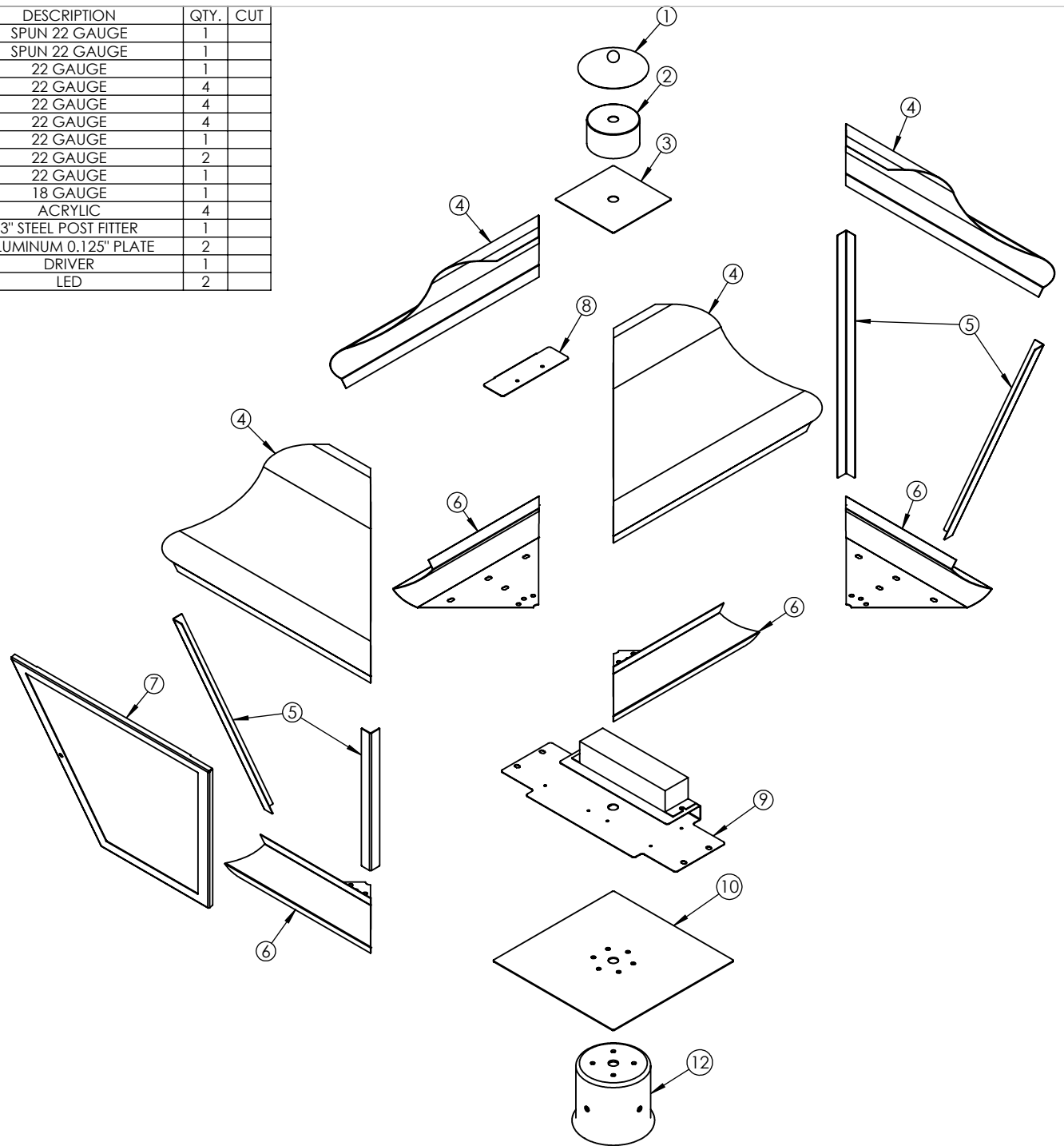

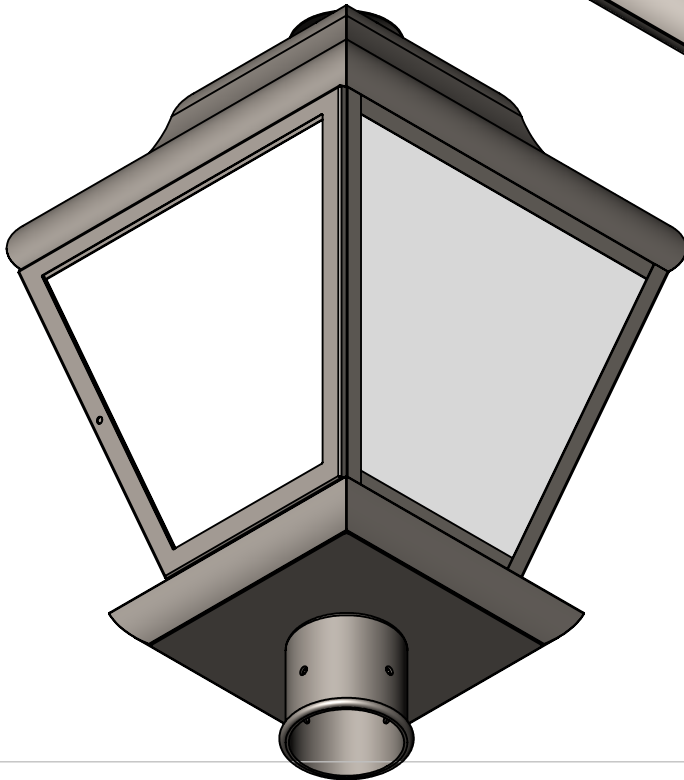
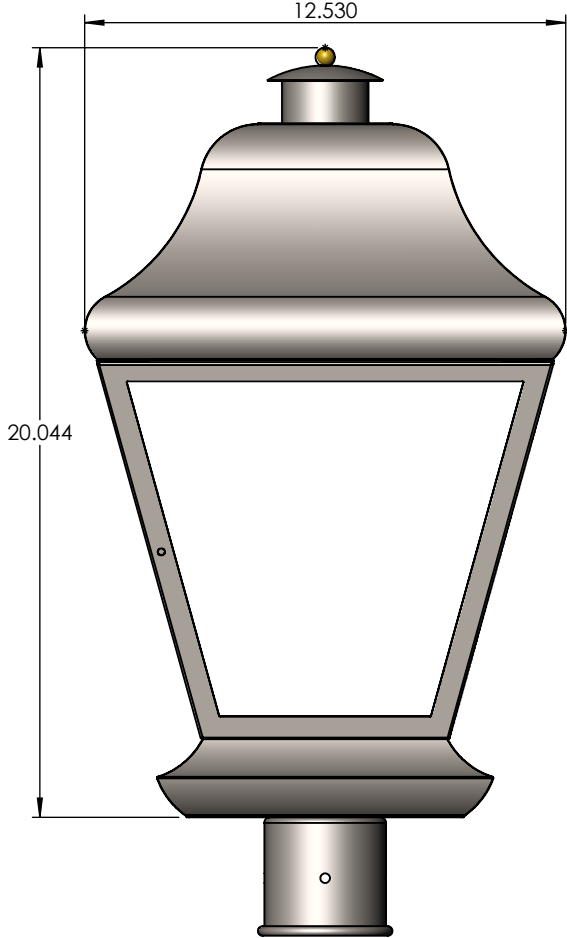
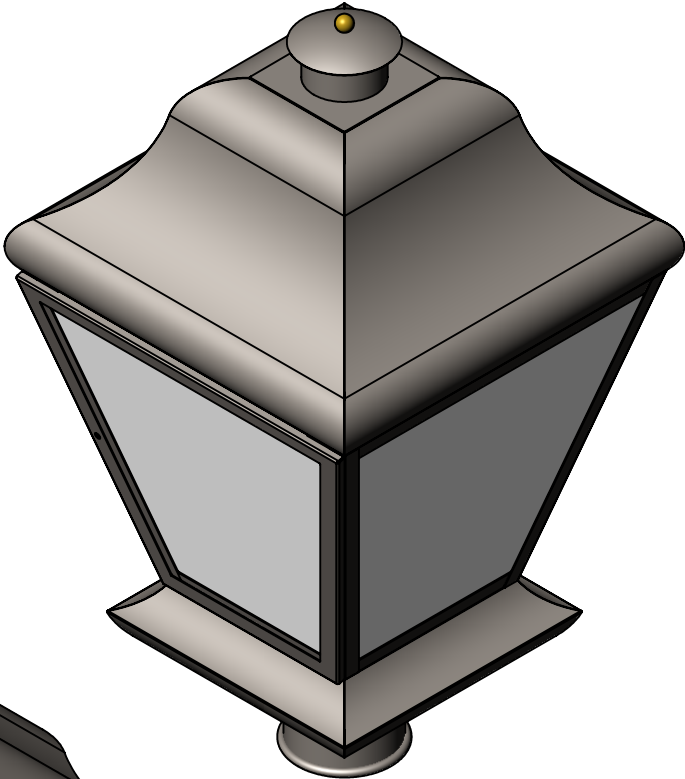
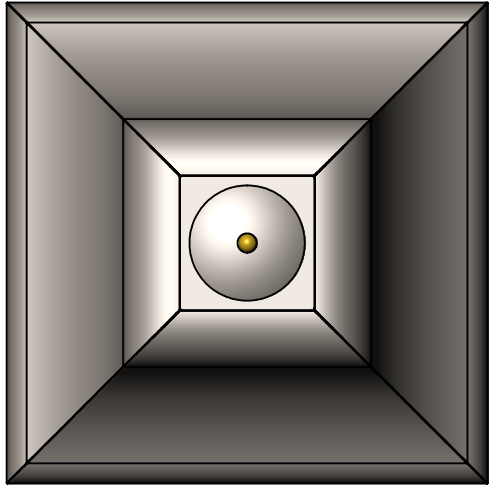

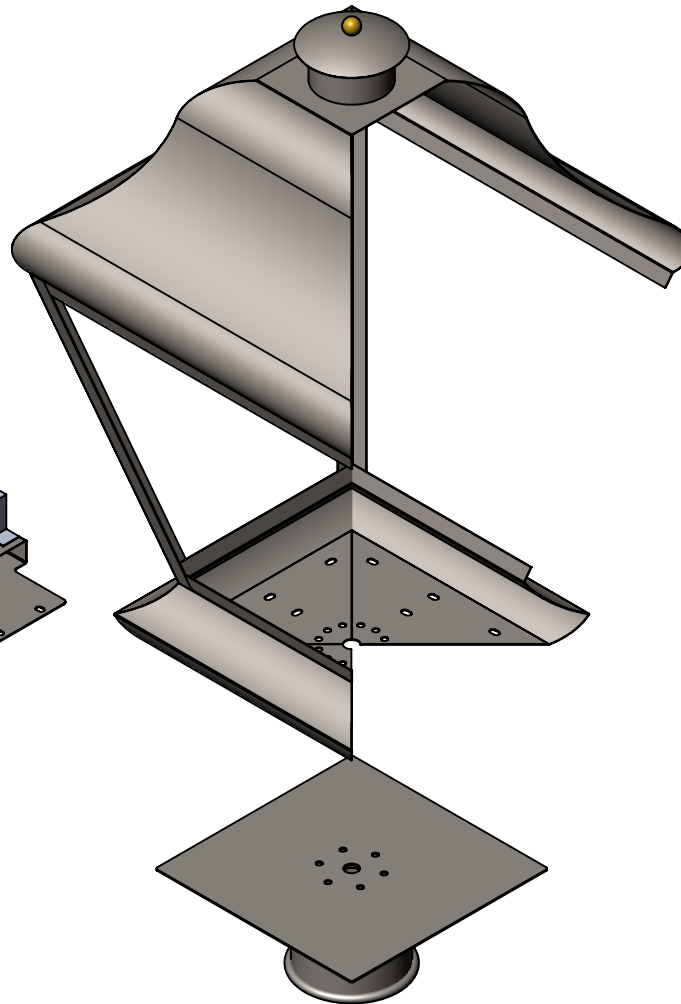
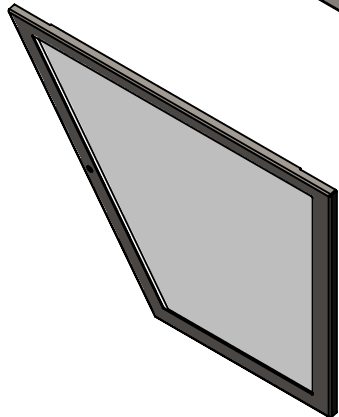
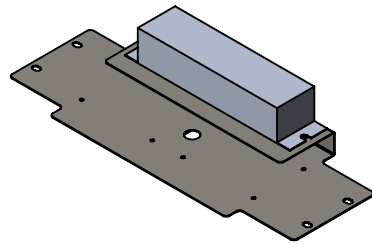
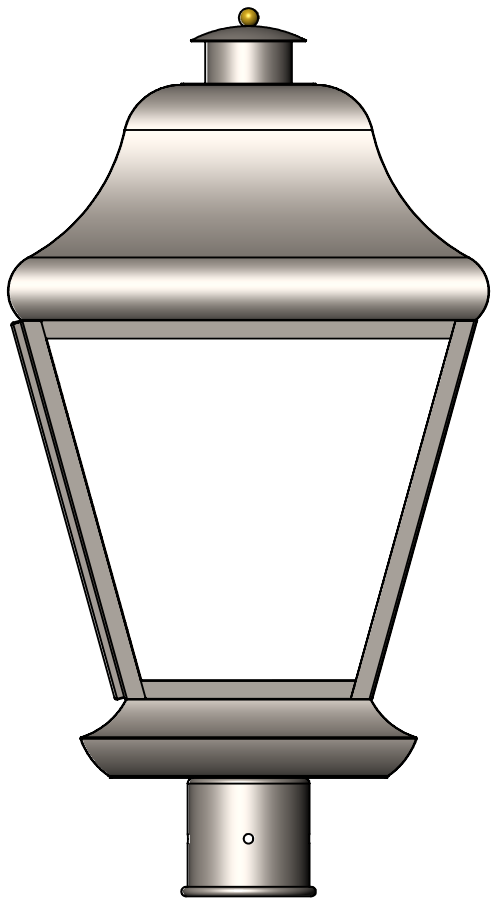

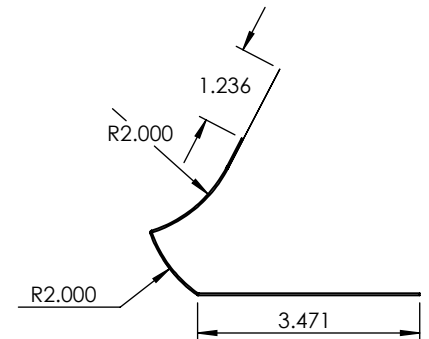
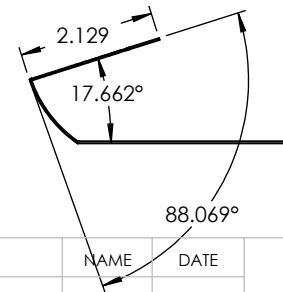
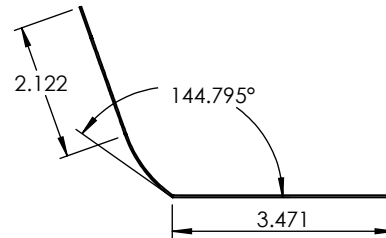
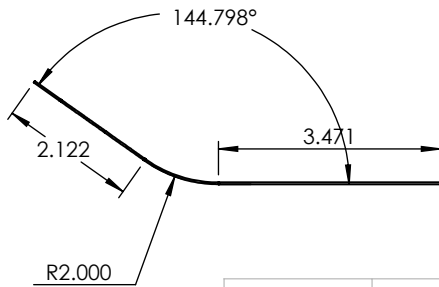
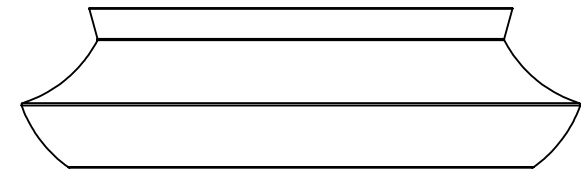
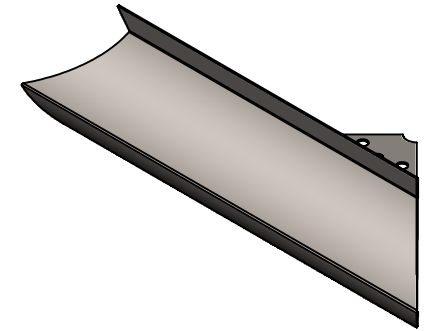
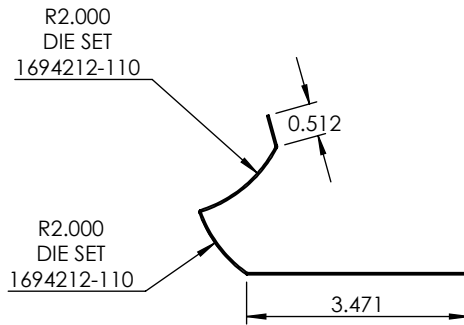
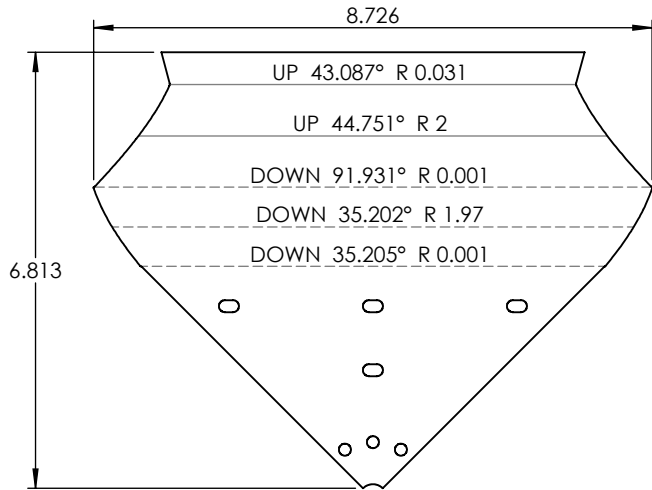

PROPRIETARY AND CONFIDENTIAL
 THE INFORMATION CONTAINED IN THIS DRAWING IS THE SOLE PROPERTY OF <INSERT COMPANY NAME HERE>. ANY REPRODUCTION IN PART OR AS A WHOLE WITHOUT THE WRITTEN PERMISSION OF <INSERT COMPANY NAME HERE> IS PROHIBITED.

		UNLESS OTHERWISE SPECIFIED:	NAME	DATE
		DIMENSIONS ARE IN INCHES	DRAWN	
		TOLERANCES:	CHECKED	
		FRACTIONAL ±	ENG APPR.	
		ANGULAR: MACH ± BEND ±	MFG APPR.	
		TWO PLACE DECIMAL ±	Q.A.	
		THREE PLACE DECIMAL ±	COMMENTS:	
		INTERPRET GEOMETRIC TOLERANCING PER:		
		MATERIAL		
NEXT ASSY	USED ON	FINISH		
APPLICATION		DO NOT SCALE DRAWING		

22 GAUGE

TITLE:
 PAL4320LS-MBK-WF-30K

SIZE A	DWG. NO.	REV
SCALE: 1:3	WEIGHT:	SHEET 6 OF 13

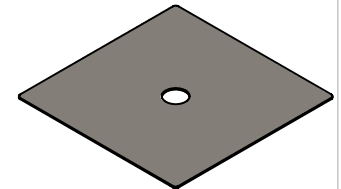
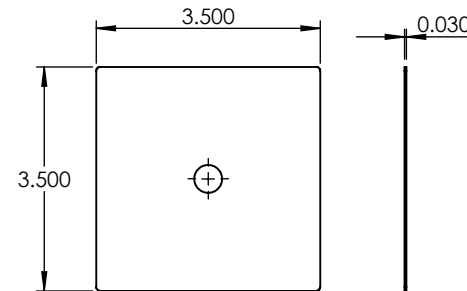
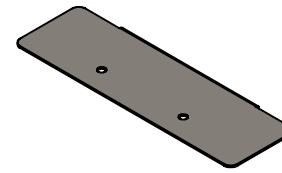
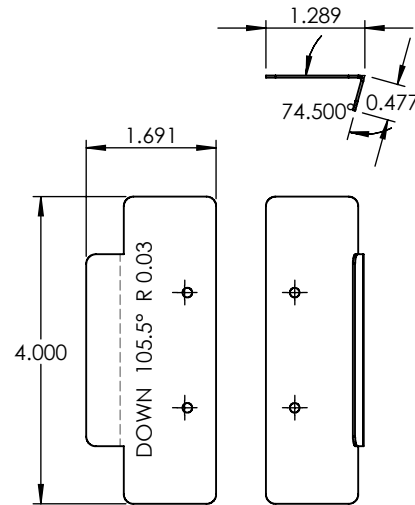
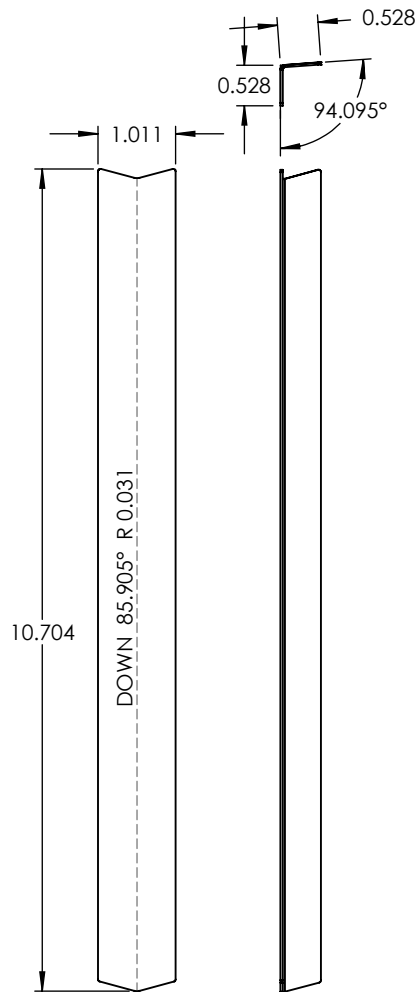

PROPRIETARY AND CONFIDENTIAL
 THE INFORMATION CONTAINED IN THIS DRAWING IS THE SOLE PROPERTY OF <INSERT COMPANY NAME HERE>. ANY REPRODUCTION IN PART OR AS A WHOLE WITHOUT THE WRITTEN PERMISSION OF <INSERT COMPANY NAME HERE> IS PROHIBITED.

		UNLESS OTHERWISE SPECIFIED:	NAME	DATE	22 GAUGE	
		DIMENSIONS ARE IN INCHES TOLERANCES: FRACTIONAL ± ANGULAR: MACH ± BEND ± TWO PLACE DECIMAL ± THREE PLACE DECIMAL ±	DRAWN			
		INTERPRET GEOMETRIC TOLERANCING PER:	CHECKED			
		MATERIAL	ENG APPR.			
		FINISH	MFG APPR.			
NEXT ASSY	USED ON		Q.A.		SIZE	REV
APPLICATION		DO NOT SCALE DRAWING	COMMENTS:		DWG. NO.	
					SCALE: 1:2.5	WEIGHT:
					SHEET 7 OF 13	

5

4

3

2

1

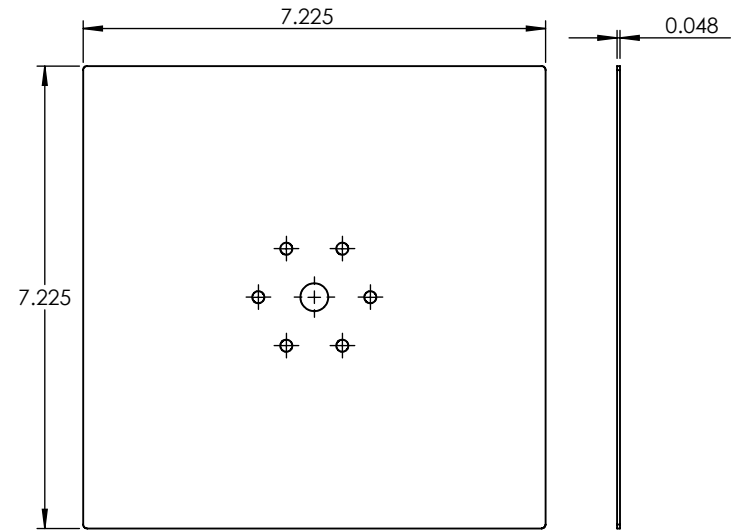
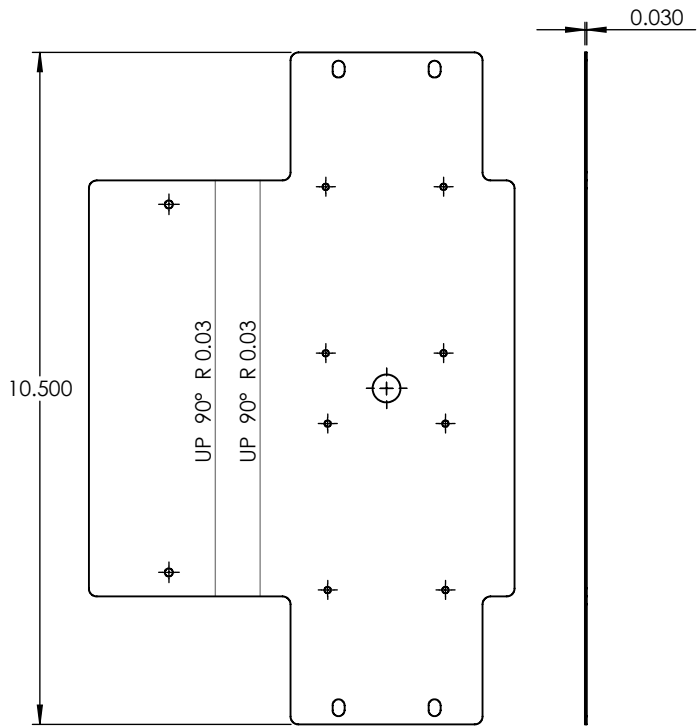
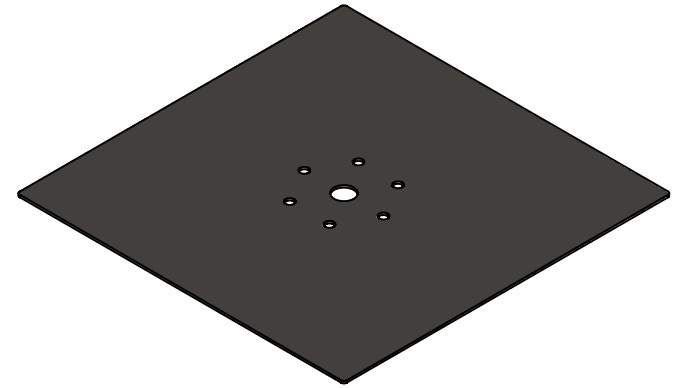
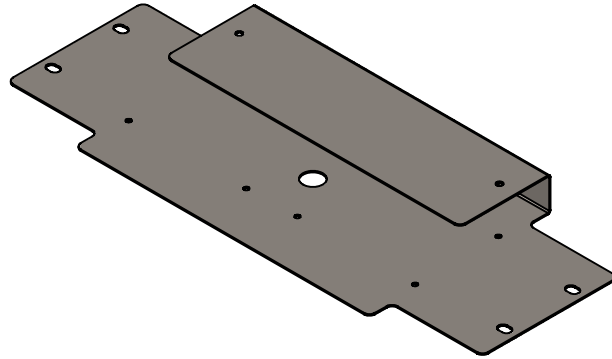

UNLESS OTHERWISE SPECIFIED:		NAME	DATE	22 GAUGE	
DIMENSIONS ARE IN INCHES TOLERANCES: FRACTIONAL ± ANGULAR: MACH ± BEND ± TWO PLACE DECIMAL ± THREE PLACE DECIMAL ±		DRAWN			
INTERPRET GEOMETRIC TOLERANCING PER:		CHECKED		SIZE DWG. NO. REV	
MATERIAL		ENG APPR.			
FINISH		MFG APPR.		SCALE: 1:3 WEIGHT: SHEET 8 OF 13	
NEXT ASSY		USED ON	Q.A.		
APPLICATION		DO NOT SCALE DRAWING	COMMENTS:		

PROPRIETARY AND CONFIDENTIAL
THE INFORMATION CONTAINED IN THIS DRAWING IS THE SOLE PROPERTY OF <INSERT COMPANY NAME HERE>. ANY REPRODUCTION IN PART OR AS A WHOLE WITHOUT THE WRITTEN PERMISSION OF <INSERT COMPANY NAME HERE> IS PROHIBITED.

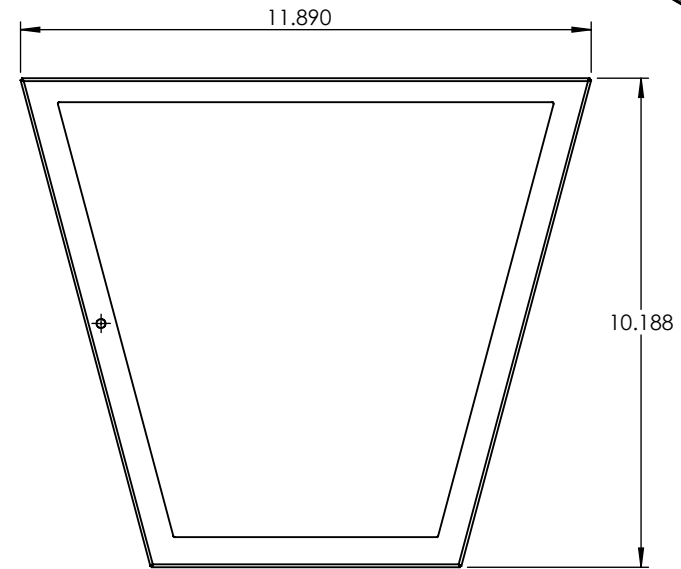
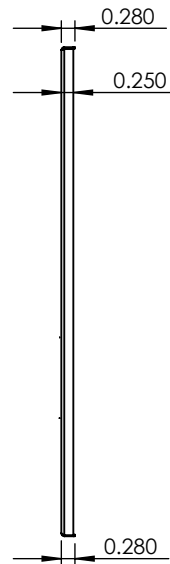
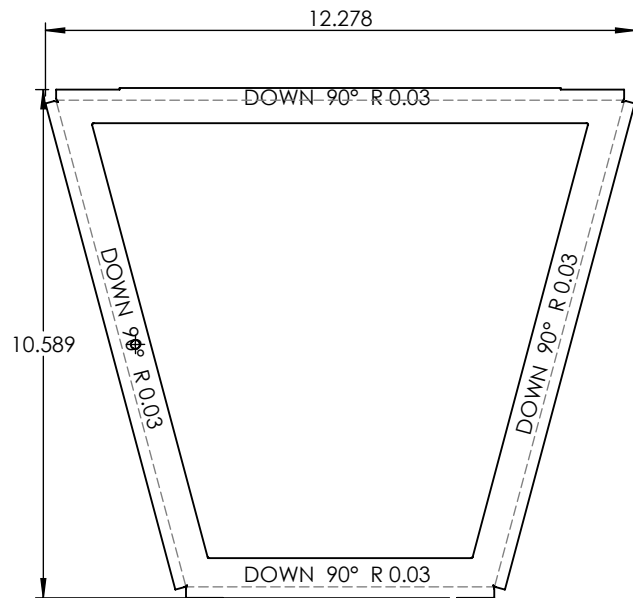
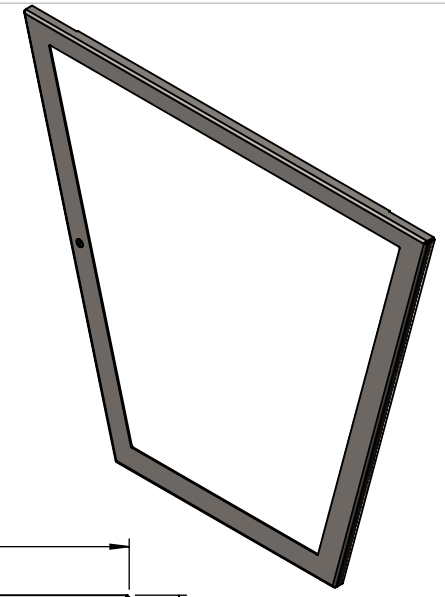

PROPRIETARY AND CONFIDENTIAL
 THE INFORMATION CONTAINED IN THIS DRAWING IS THE SOLE PROPERTY OF <INSERT COMPANY NAME HERE>. ANY REPRODUCTION IN PART OR AS A WHOLE WITHOUT THE WRITTEN PERMISSION OF <INSERT COMPANY NAME HERE> IS PROHIBITED.

		UNLESS OTHERWISE SPECIFIED:		NAME	DATE	22 GAUGE	
		DIMENSIONS ARE IN INCHES TOLERANCES: FRACTIONAL ± ANGULAR: MACH ± BEND ± TWO PLACE DECIMAL ± THREE PLACE DECIMAL ±		DRAWN			
		INTERPRET GEOMETRIC TOLERANCING PER:		CHECKED		SIZE DWG. NO. REV	
		MATERIAL		ENG APPR.			
		FINISH		MFG APPR.		SCALE: 1:4 WEIGHT: SHEET 9 OF 13	
NEXT ASSY	USED ON			Q.A.			
APPLICATION		DO NOT SCALE DRAWING		COMMENTS:			

ITEM NO.	PART NUMBER	DESCRIPTION	QTY.
1	PAL2224L-ORB-WF-30K-TOP SPUN CAP	SPUN 22 GAUGE	1

ITEM NO.	PART NUMBER	DESCRIPTION	QTY.
1	MAD4320L-ORB-A-41K-TOP ROLLED CIRCLE	22 GAUGE	1

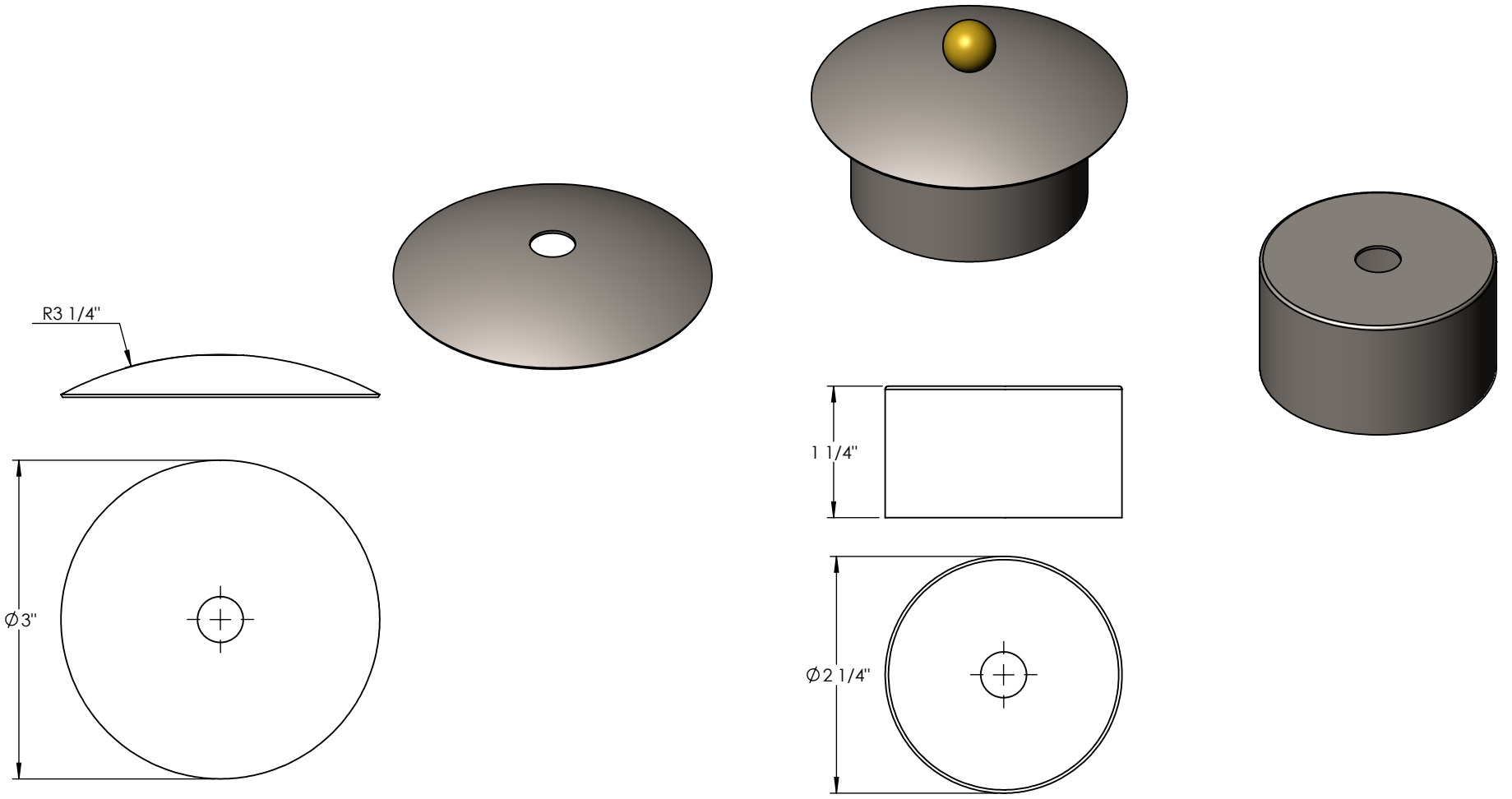

PROPRIETARY AND CONFIDENTIAL
 THE INFORMATION CONTAINED IN THIS DRAWING IS THE SOLE PROPERTY OF <INSERT COMPANY NAME HERE>. ANY REPRODUCTION IN PART OR AS A WHOLE WITHOUT THE WRITTEN PERMISSION OF <INSERT COMPANY NAME HERE> IS PROHIBITED.

		UNLESS OTHERWISE SPECIFIED:	NAME	DATE
		DIMENSIONS ARE IN INCHES TOLERANCES: FRACTIONAL ± ANGULAR: MACH ± BEND ± TWO PLACE DECIMAL ± THREE PLACE DECIMAL ±	DRAWN	
		INTERPRET GEOMETRIC TOLERANCING PER:	CHECKED	
		MATERIAL	ENG APPR.	
		FINISH	MFG APPR.	
			Q.A.	
			COMMENTS:	
NEXT ASSY	USED ON			
APPLICATION		DO NOT SCALE DRAWING		

TITLE:		
SPUN 22 GAUGE		
PAL4320LS-MBK-WF-30K		
SIZE	DWG. NO.	REV
A		
SCALE: 1:1.5WEIGHT:		SHEET 10 OF 13

ITEM NO.	PART NUMBER	DESCRIPTION	QTY.
1	POST FITTER	3" STEEL POST FITTER	1

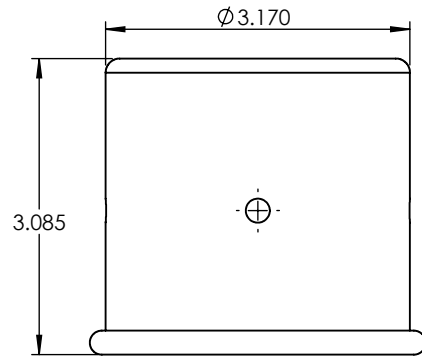
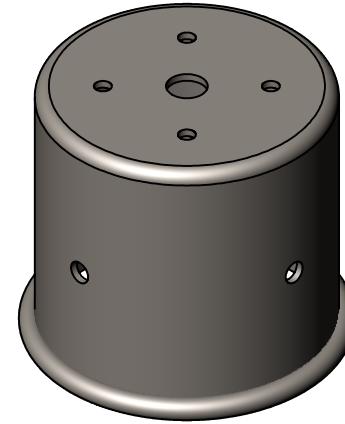
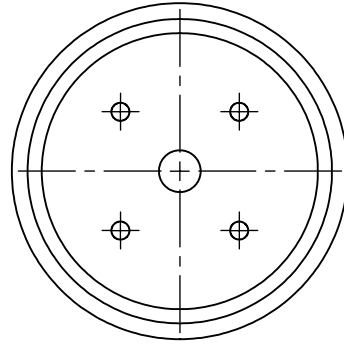

PROPRIETARY AND CONFIDENTIAL
 THE INFORMATION CONTAINED IN THIS DRAWING IS THE SOLE PROPERTY OF <INSERT COMPANY NAME HERE>. ANY REPRODUCTION IN PART OR AS A WHOLE WITHOUT THE WRITTEN PERMISSION OF <INSERT COMPANY NAME HERE> IS PROHIBITED.

		UNLESS OTHERWISE SPECIFIED:		NAME	DATE	3" STEEL POST FITTER		
		DIMENSIONS ARE IN INCHES TOLERANCES: FRACTIONAL ± ANGULAR: MACH ± BEND ± TWO PLACE DECIMAL ± THREE PLACE DECIMAL ±	DRAWN					
		INTERPRET GEOMETRIC TOLERANCING PER:	CHECKED			PAL4320LS-MBK-WF-30K		
		MATERIAL	ENG APPR.			SIZE	DWG. NO.	REV
		FINISH	MFG APPR.			A		
NEXT ASSY	USED ON		Q.A.					
APPLICATION		DO NOT SCALE DRAWING	COMMENTS:			SCALE: 1:2	WEIGHT:	SHEET 11 OF 13

