

ITEM NO.	PART NUMBER	DESCRIPTION	QTY.	CUT
1	ECL-W-24L-AB-WF-PE-TBL-WET-30K-FRAME	22 GAUGE	1	
2	ECL-W-24L-AB-WF-PE-TBL-WET-30K-BACKPLATE	22 GAUGE	1	
3	ECL-W-24L-AB-WF-PE-TBL-WET-30K-FIREPLATE	22 GAUGE	1	
4	ECL-W-24L-AB-WF-PE-TBL-WET-30K-TAB	22 GAUGE	4	
5	ECL-W-24L-AB-WF-PE-TBL-WET-30K-ACRYLIC	ACRYLIC	1	
6	ECL-W-24L-AB-WF-PE-TBL-WET-30K-FLAT BAR	1/4"X1/2" ALUMINUM FLAT BAR BAR	1	
7	PHOTO CELL MODEL 2.0	SENSOR	1	
8	KTLD-25-UV-700-VDIM-LA1	DRIVER	1	
9	Altiled_PN110B_RevC	LED	2	

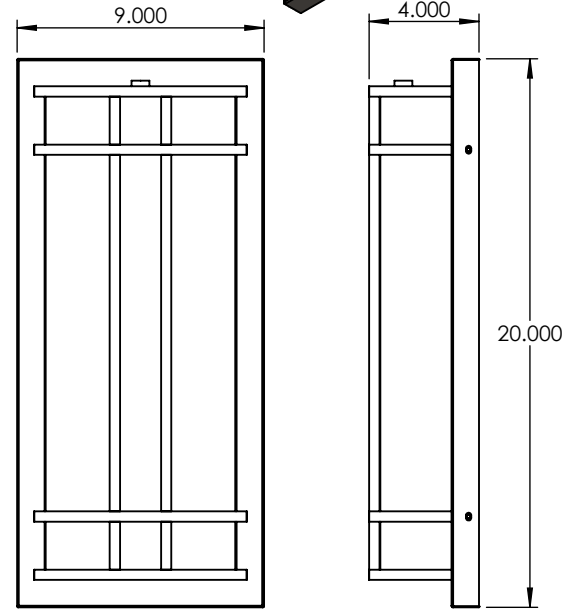
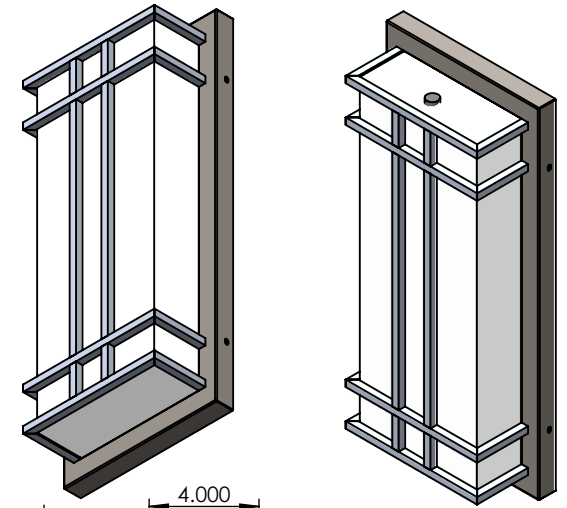
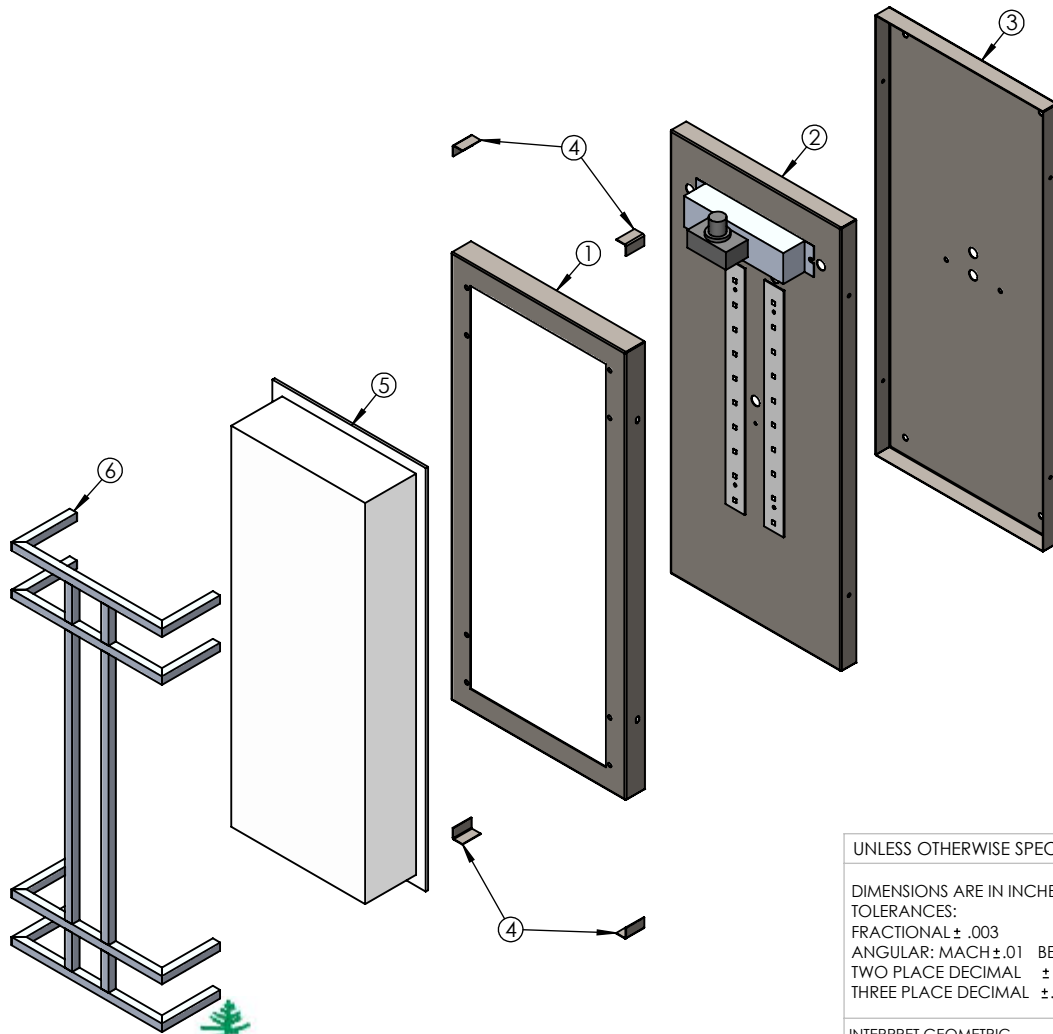

ALL BEND RADIUS .030"

APPLICATION

DO NOT SCALE DRAWING

UNLESS OTHERWISE SPECIFIED:

DIMENSIONS ARE IN INCHES
 TOLERANCES:
 FRACTIONAL ± .003
 ANGULAR: MACH ± .01 BEND ±
 TWO PLACE DECIMAL ±
 THREE PLACE DECIMAL ± .001

INTERPRET GEOMETRIC
 TOLERANCING PER:

MATERIAL

FINISH

NAME

DATE

DRAWN

CHECKED

ENG APPR.

MFG APPR.

Q.A.

COMMENTS:

TITLE:

ECL-W-24L-AB-WF-PE-TBL-WET-30K

SIZE DWG. NO.

A TICKET 24435

REV

SCALE: 1:7 WEIGHT:

SHEET 1 OF 7

5

4

3

2

1

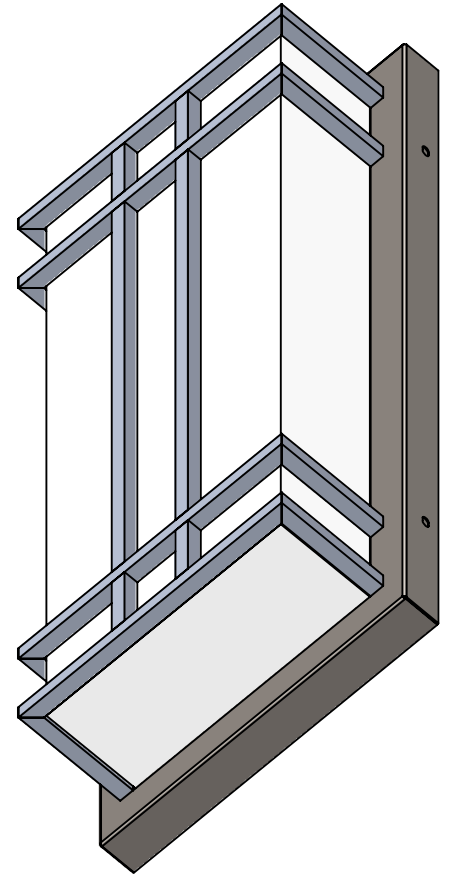
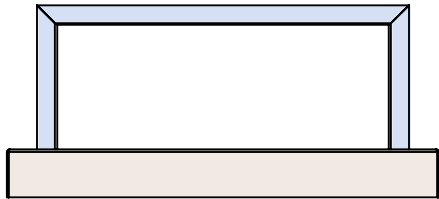
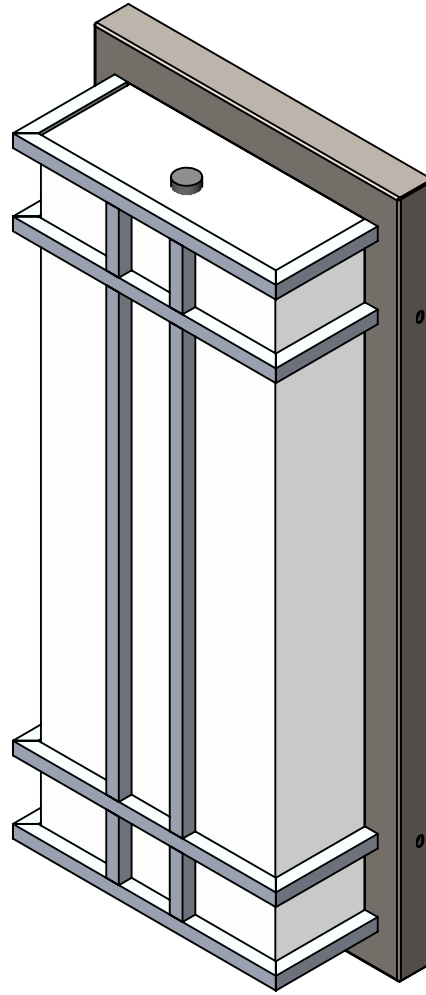
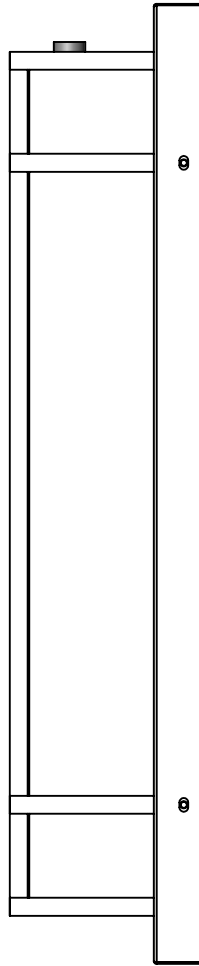
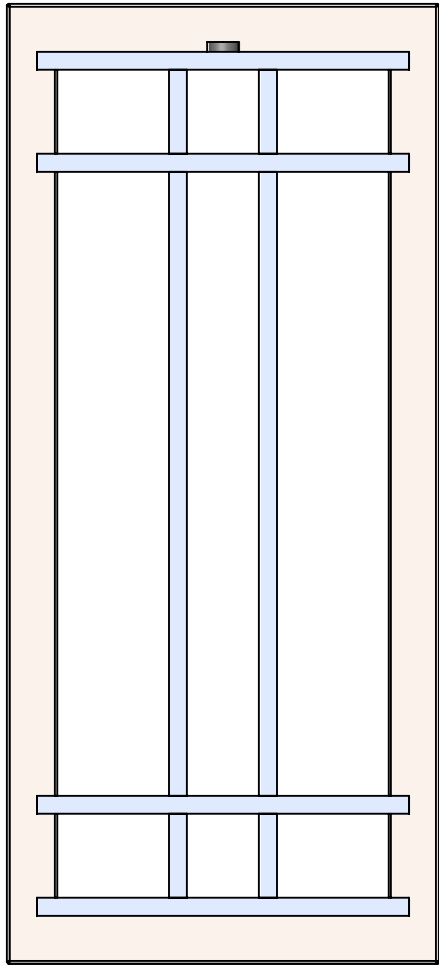

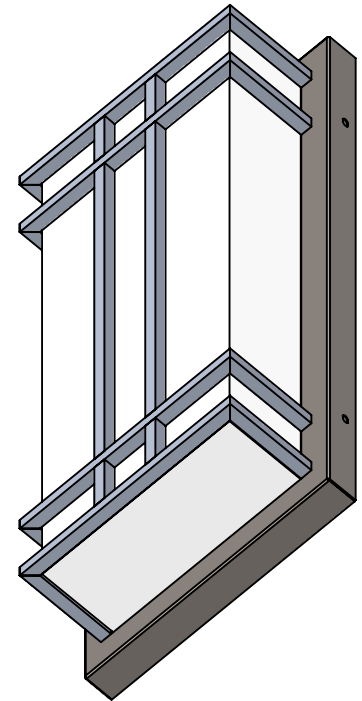
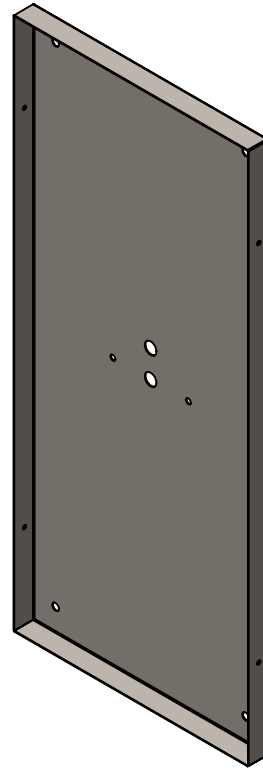
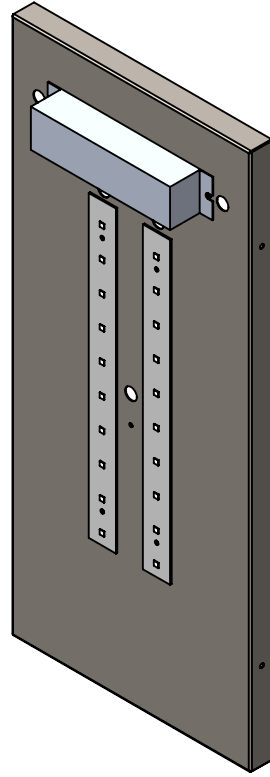
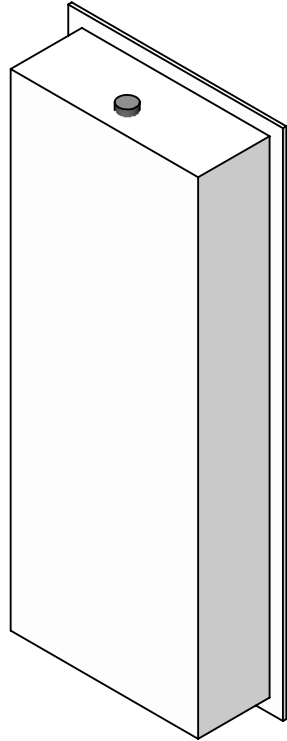
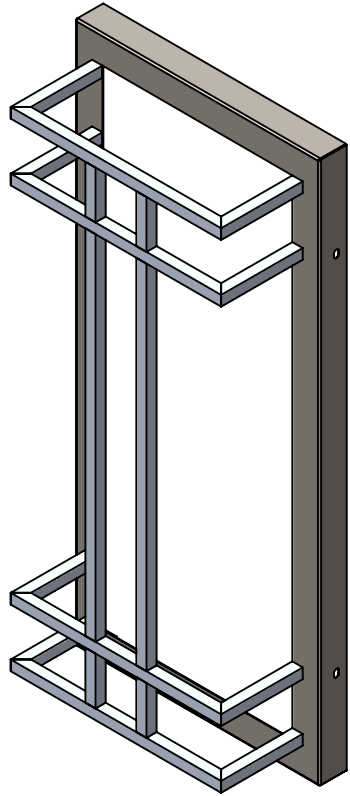

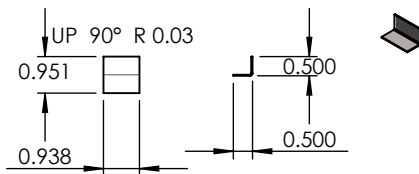
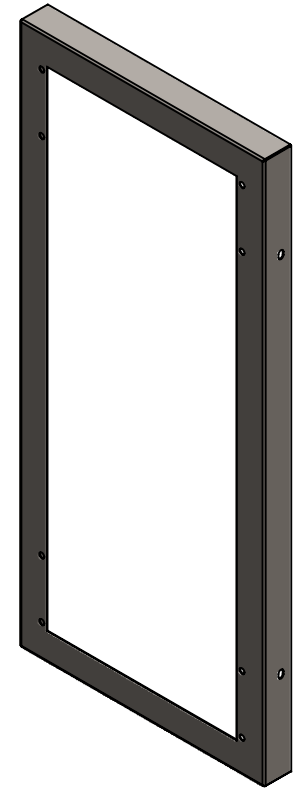
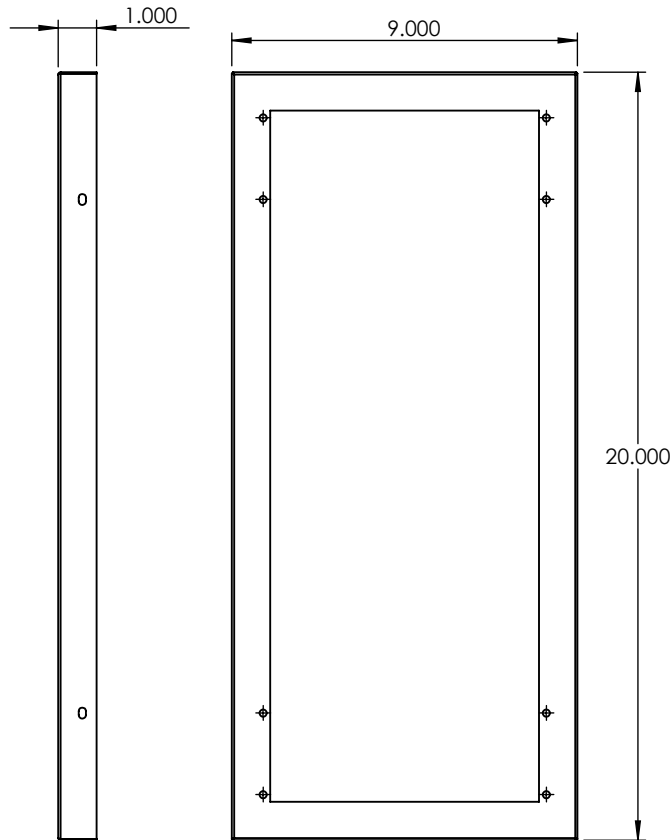
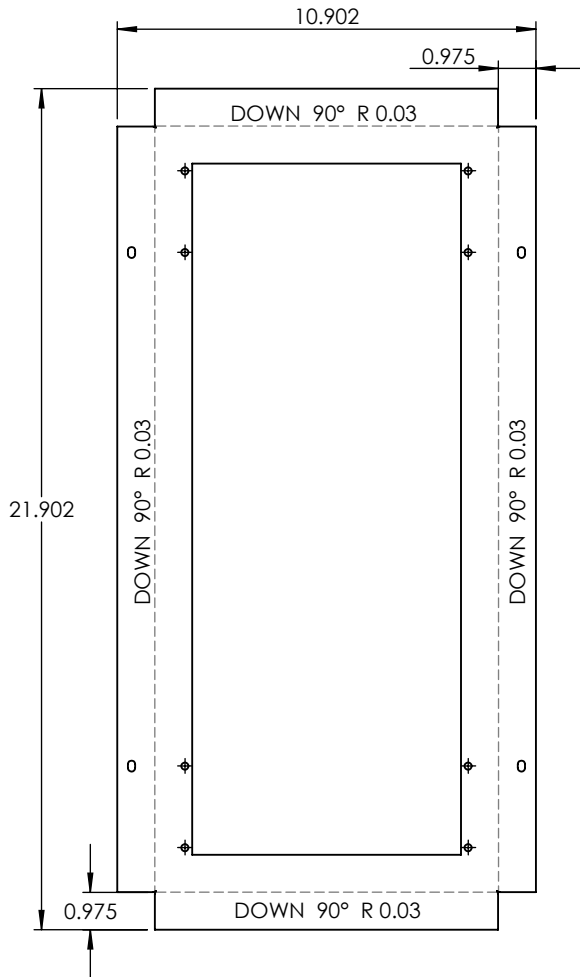

PROPRIETARY AND CONFIDENTIAL
 THE INFORMATION CONTAINED IN THIS DRAWING IS THE SOLE PROPERTY OF <INSERT COMPANY NAME HERE>. ANY REPRODUCTION IN PART OR AS A WHOLE WITHOUT THE WRITTEN PERMISSION OF <INSERT COMPANY NAME HERE> IS PROHIBITED.

NEXT ASSY	USED ON	FINISH
APPLICATION		DO NOT SCALE DRAWING

UNLESS OTHERWISE SPECIFIED: DIMENSIONS ARE IN INCHES TOLERANCES: FRACTIONAL ± ANGULAR: MACH ± BEND ± TWO PLACE DECIMAL ± THREE PLACE DECIMAL ±	NAME	DATE	22 GAUGE	
	DRAWN			
	CHECKED		ECL-W-24L-AB-WF-PE-TBL-WET-30K	
	ENG APPR.		SIZE	DWG. NO.
MFG APPR.		SCALE: 1:5		
Q.A.		WEIGHT:		SHEET 4 OF 7
COMMENTS:				

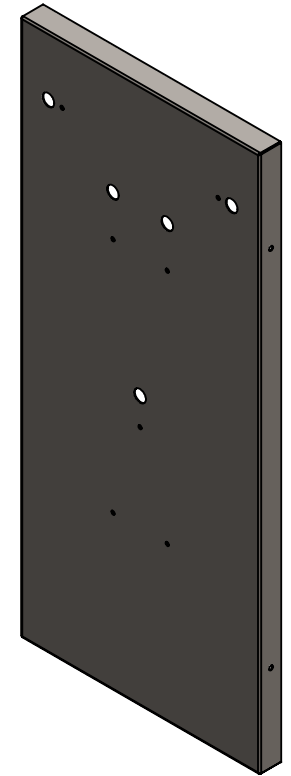
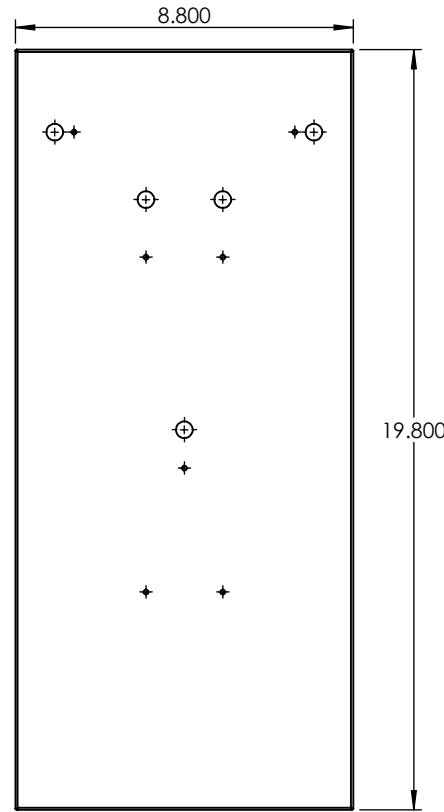
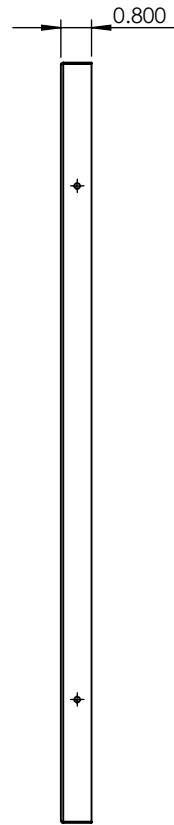
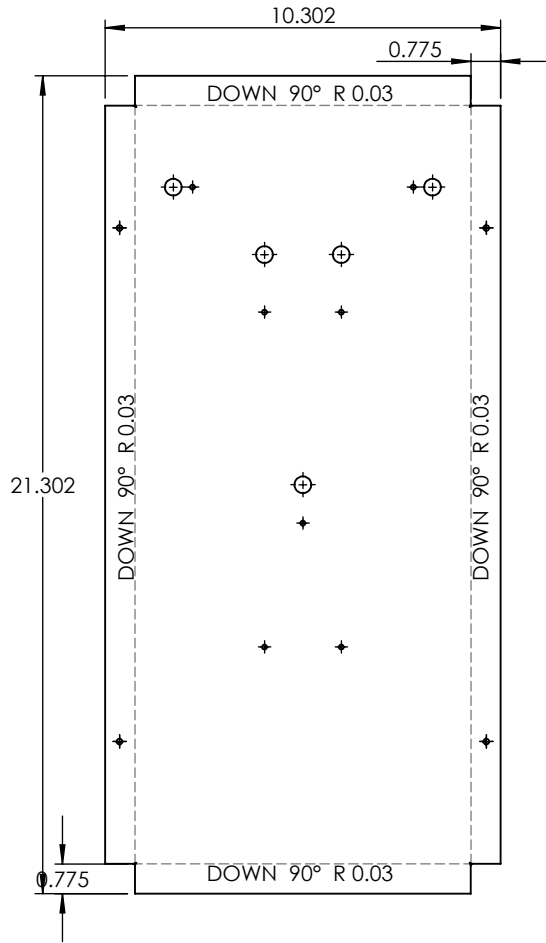

PROPRIETARY AND CONFIDENTIAL
 THE INFORMATION CONTAINED IN THIS DRAWING IS THE SOLE PROPERTY OF <INSERT COMPANY NAME HERE>. ANY REPRODUCTION IN PART OR AS A WHOLE WITHOUT THE WRITTEN PERMISSION OF <INSERT COMPANY NAME HERE> IS PROHIBITED.

		UNLESS OTHERWISE SPECIFIED:	NAME	DATE	22 GAUGE	
		DIMENSIONS ARE IN INCHES	DRAWN		TITLE:	
		TOLERANCES:	CHECKED		ECL-W-24L-AB-WF-PE-TBL-WET-30K	
		FRACTIONAL ±	ENG APPR.		SIZE DWG. NO. REV	
		ANGULAR: MACH ± BEND ±	MFG APPR.		SCALE: 1:5 WEIGHT: SHEET 5 OF 7	
		TWO PLACE DECIMAL ±	Q.A.			
		THREE PLACE DECIMAL ±	COMMENTS:			
		INTERPRET GEOMETRIC TOLERANCING PER:				
		MATERIAL				
NEXT ASSY	USED ON	FINISH				
APPLICATION		DO NOT SCALE DRAWING				

5

4

3

2

1

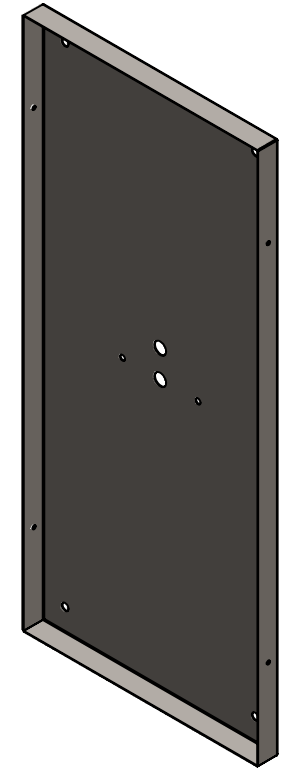
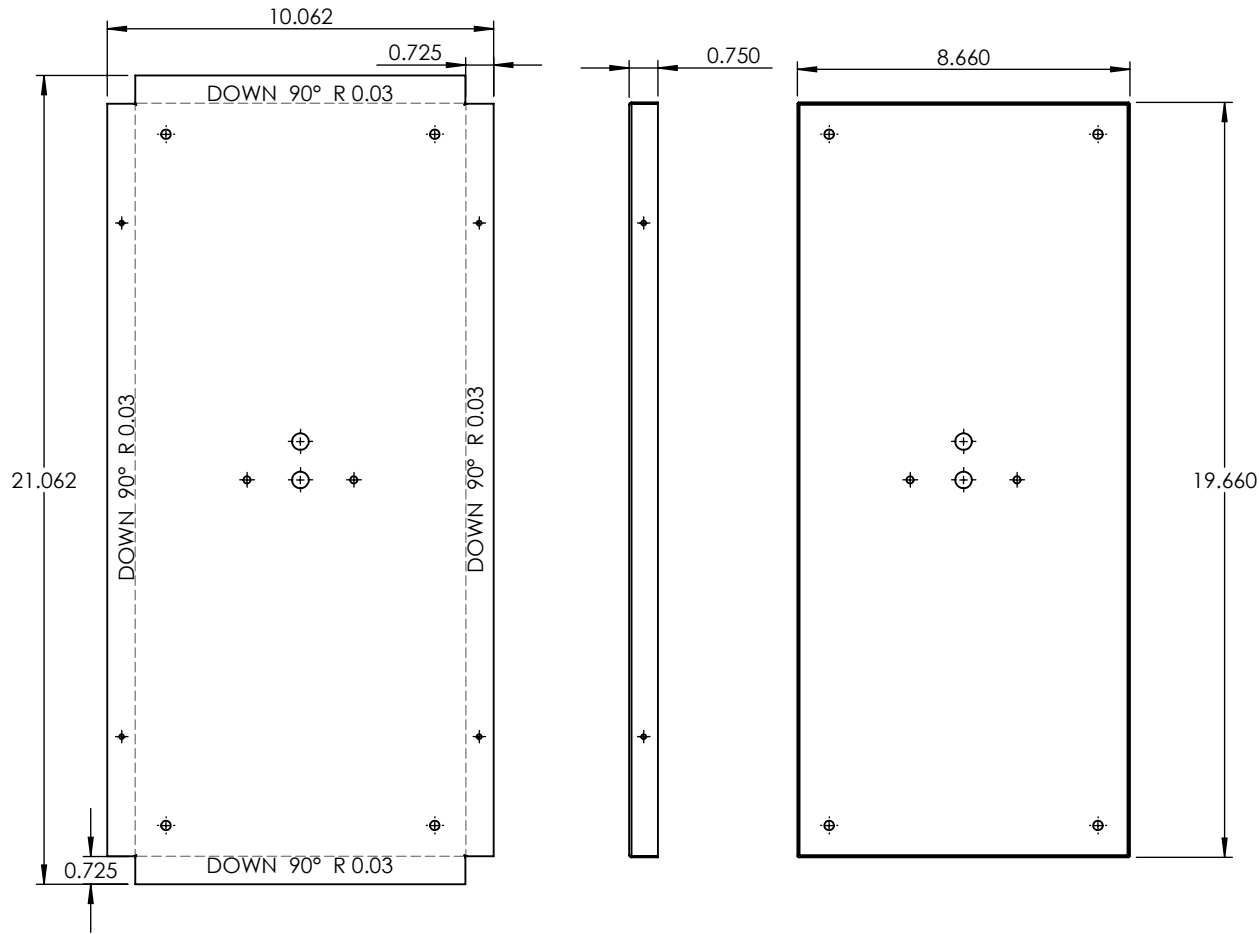

PROPRIETARY AND CONFIDENTIAL
 THE INFORMATION CONTAINED IN THIS DRAWING IS THE SOLE PROPERTY OF <INSERT COMPANY NAME HERE>. ANY REPRODUCTION IN PART OR AS A WHOLE WITHOUT THE WRITTEN PERMISSION OF <INSERT COMPANY NAME HERE> IS PROHIBITED.

		UNLESS OTHERWISE SPECIFIED:	NAME	DATE	22 GAUGE	
		DIMENSIONS ARE IN INCHES	DRAWN		TITLE:	
		TOLERANCES:	CHECKED		ECL-W-24L-AB-WF-PE-TBL-WET-30K	
		FRACTIONAL ±	ENG APPR.		SIZE DWG. NO. REV	
		ANGULAR: MACH ± BEND ±	MFG APPR.		SCALE: 1:5 WEIGHT: SHEET 6 OF 7	
		TWO PLACE DECIMAL ±	Q.A.			
		THREE PLACE DECIMAL ±	COMMENTS:			
		INTERPRET GEOMETRIC TOLERANCING PER:				
		MATERIAL				
NEXT ASSY	USED ON	FINISH				
APPLICATION		DO NOT SCALE DRAWING				

5

4

3

2

1

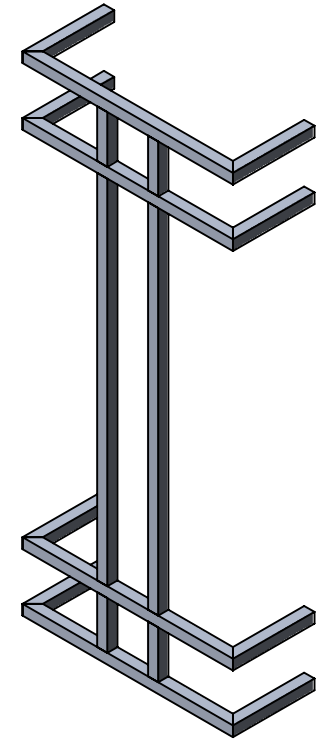
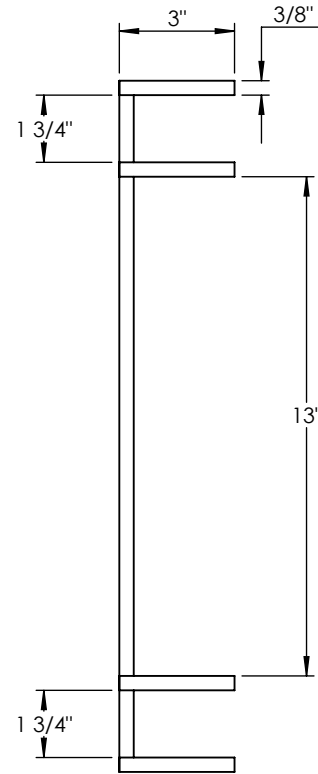
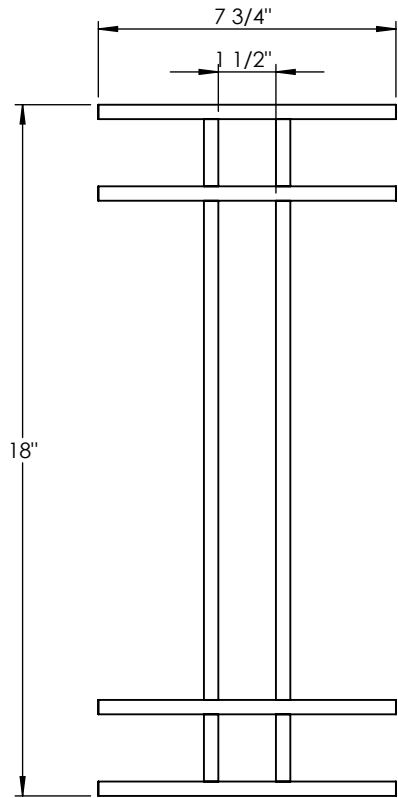
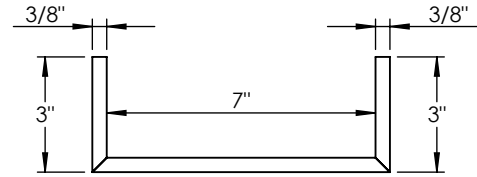

PROPRIETARY AND CONFIDENTIAL
 THE INFORMATION CONTAINED IN THIS DRAWING IS THE SOLE PROPERTY OF <INSERT COMPANY NAME HERE>. ANY REPRODUCTION IN PART OR AS A WHOLE WITHOUT THE WRITTEN PERMISSION OF <INSERT COMPANY NAME HERE> IS PROHIBITED.

NEXT ASSY	USED ON
APPLICATION	

UNLESS OTHERWISE SPECIFIED:
DIMENSIONS ARE IN INCHES
TOLERANCES:
FRACTIONAL ±
ANGULAR: MACH ± BEND ±
TWO PLACE DECIMAL ±
THREE PLACE DECIMAL ±
INTERPRET GEOMETRIC TOLERANCING PER:
MATERIAL
FINISH
DO NOT SCALE DRAWING

	NAME	DATE
DRAWN		
CHECKED		
ENG APPR.		
MFG APPR.		
Q.A.		
COMMENTS:		

1/4"X1/2" ALUMINUM FLAT BAR BAR		
TITLE:		
ECL-W-24L-AB-WF-PE-TBL-WET-30K		
SIZE	DWG. NO.	REV
A		
SCALE: 1:5	WEIGHT:	SHEET 7 OF 7