

EVERGREEN LIGHTING

5@69B8'F58+G"\$'\$"

5DD@7 5HC B

I B @GGC H: 9FK 69 GD97 ÷ 98.
 8 A 9BGC BG5F9 B' B7 < 9G
 HC @F 5B7 9G
 : F57 HC B5 @± "\$\$'
 5B: I @F: A 57 < ± "\$%''69B8 ±
 HK C D@5 7 9 8 97 A 5 @'' ±
 H: F99 D@5 7 9 8 97 A 5 @ ± "\$\$%
 B H@F DF 9H: 9C A 9F 7
 HC @F 5B7 B: D9F.
 A 5 H@F 5 @
 : B @<

8C B CHG7 5 @ 8F5K B:

	B5A 9	85H9	
	8F5K B		
	7 < 97 ? 98		
	9B: 5DDF"		
	A: : 5DDF"		
	E "5"		
	7 C A A 9BHG		
			H#@.
			@B!5A !GDFL&! '\$!(7 8@H6?!-!:%\$6
G#9	8K; ""BC"		F9J
5	H7 ? 9H&&-) &		
G7 5 @. %,	K 9 ÷ < H'		G< 99H%C: %

) (' & %

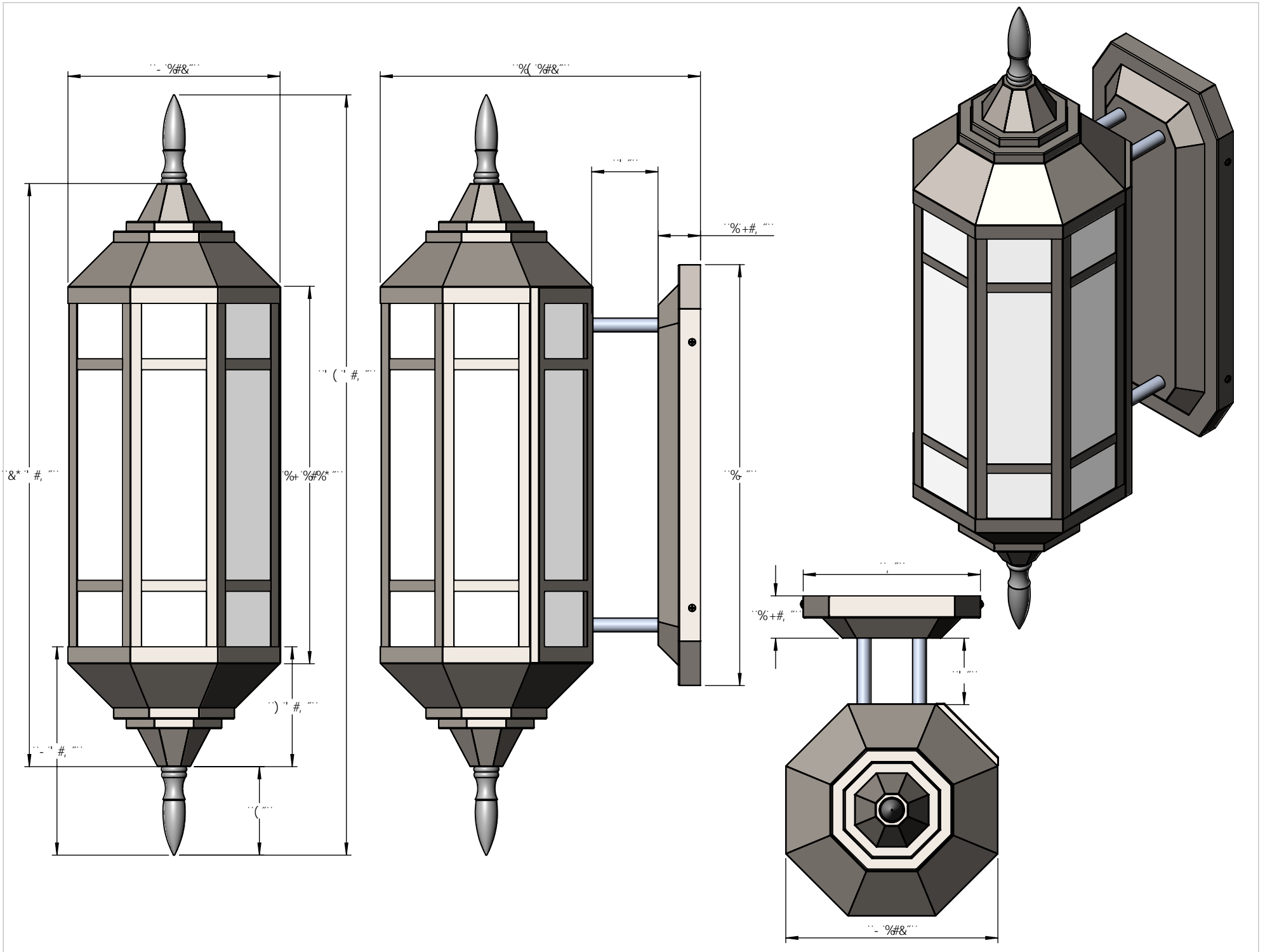

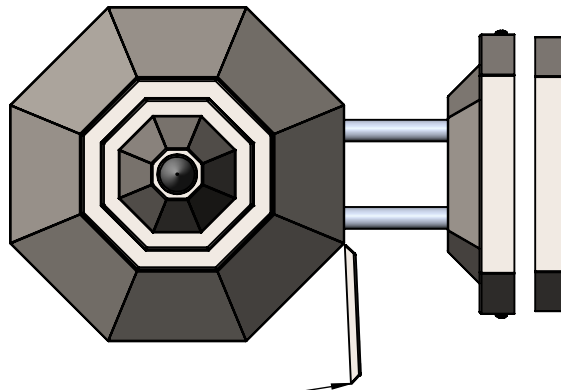
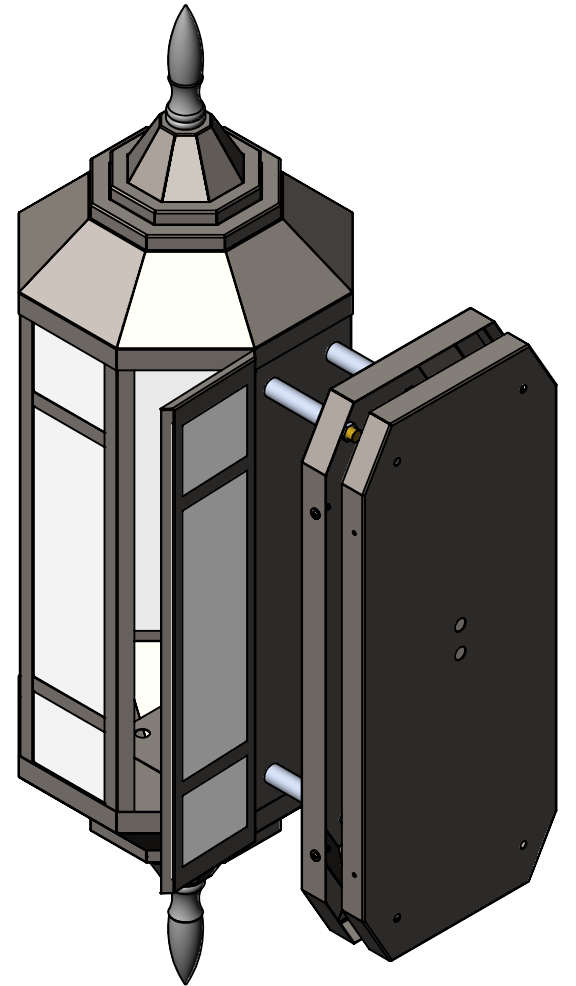
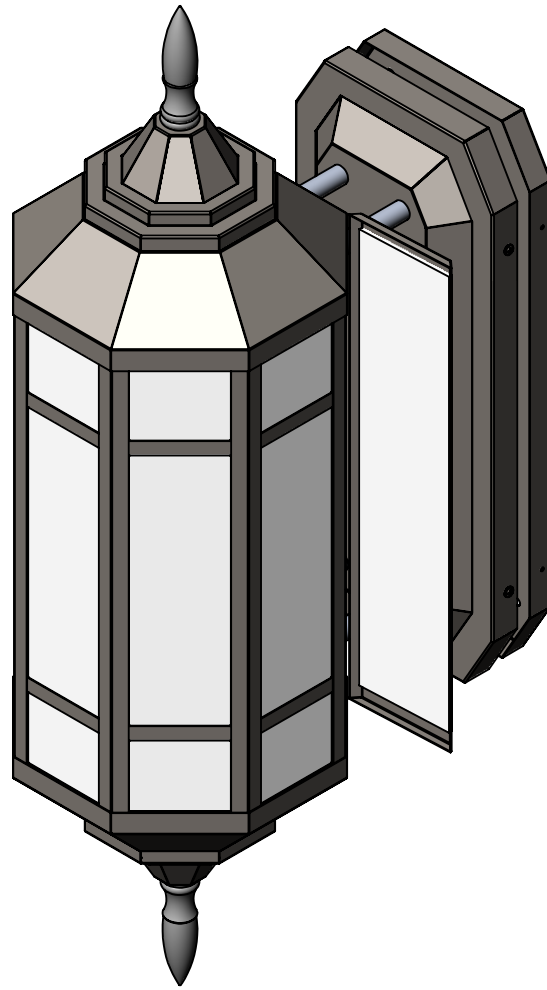
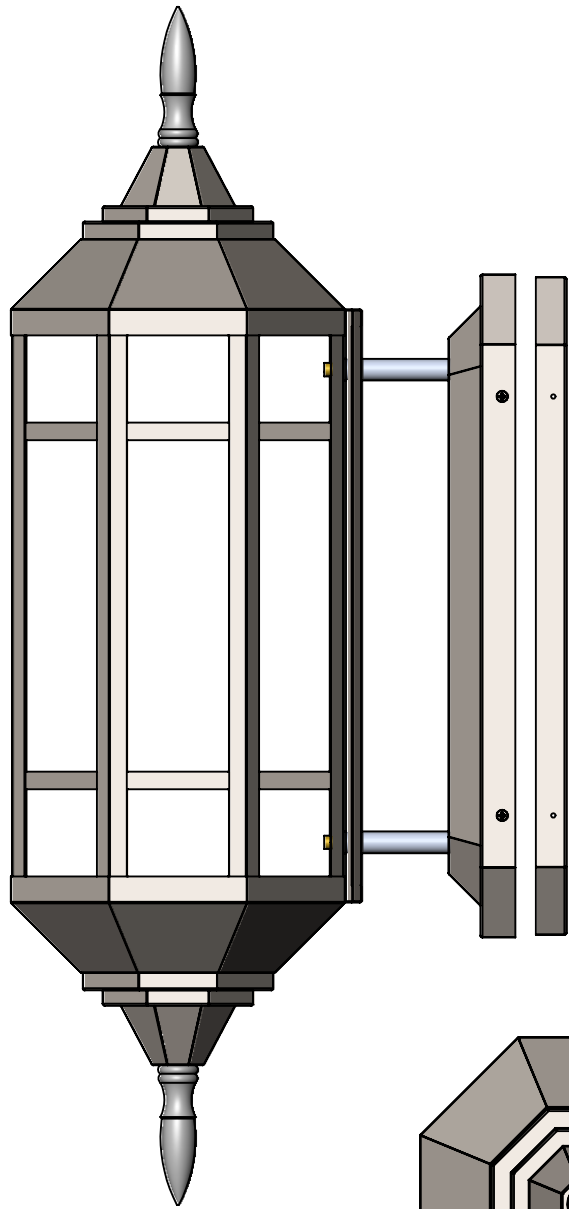

D6798CCF'CB'657?7CFB9' C: :±HF9

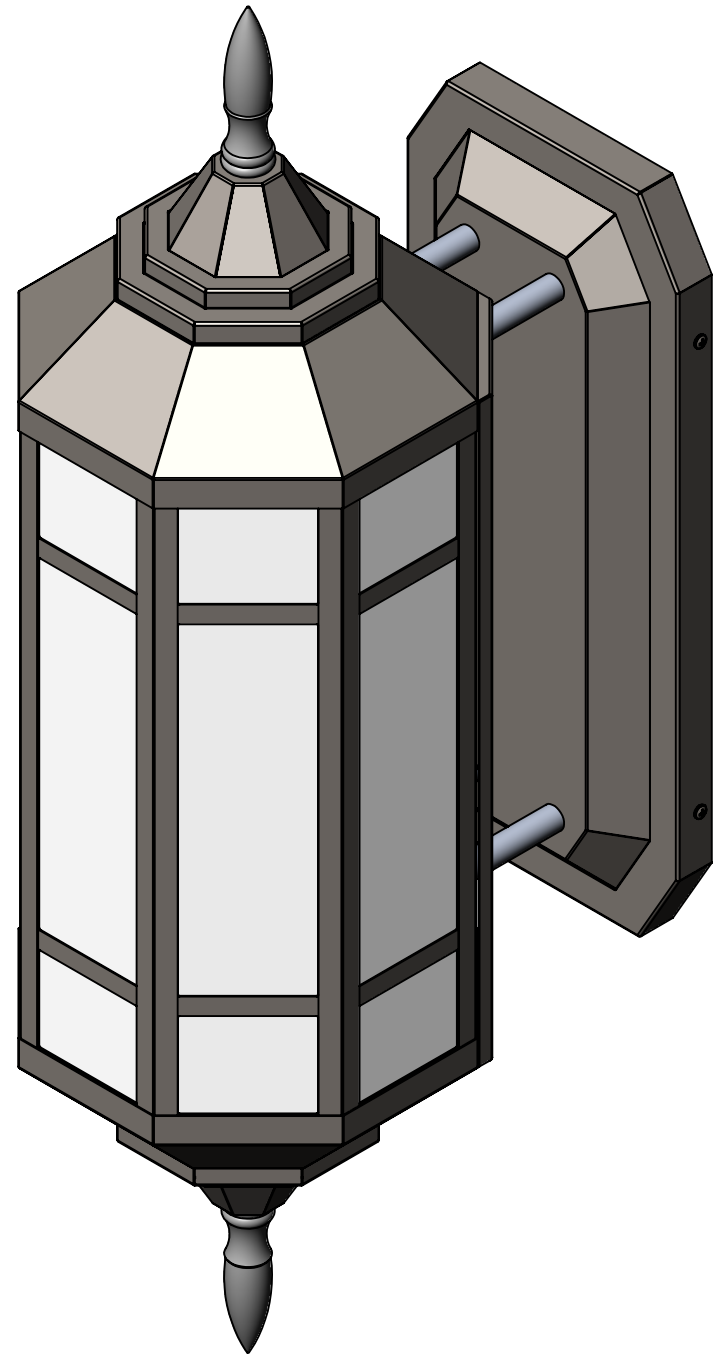
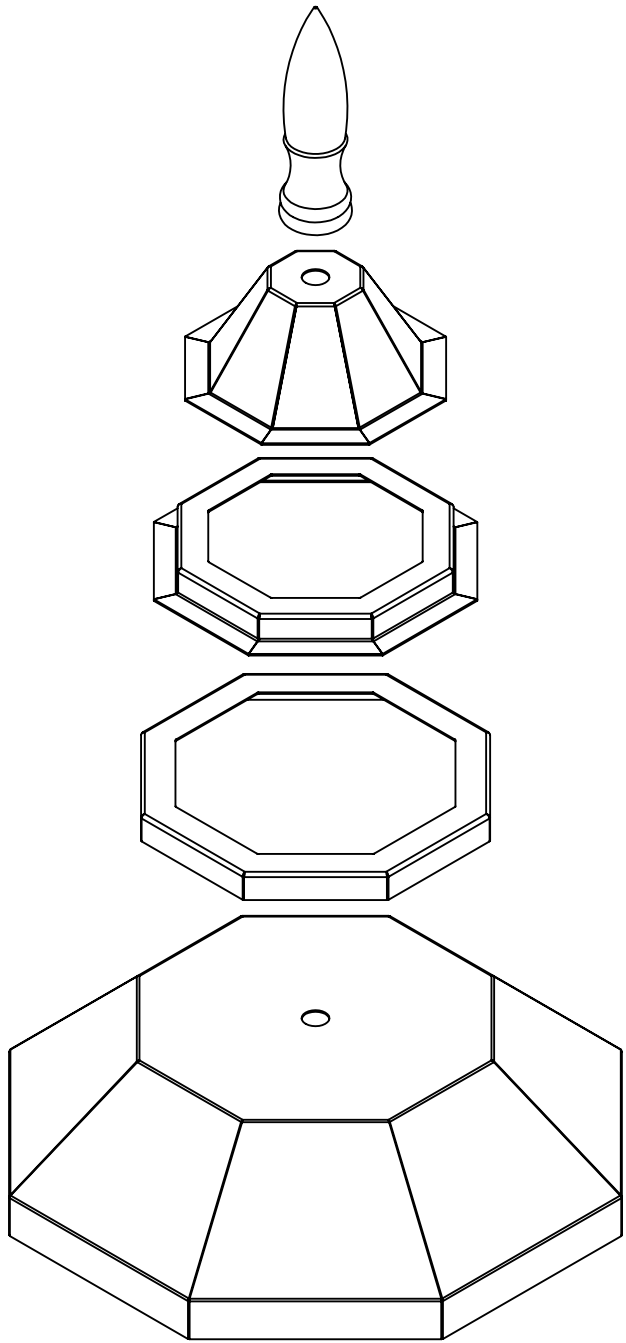

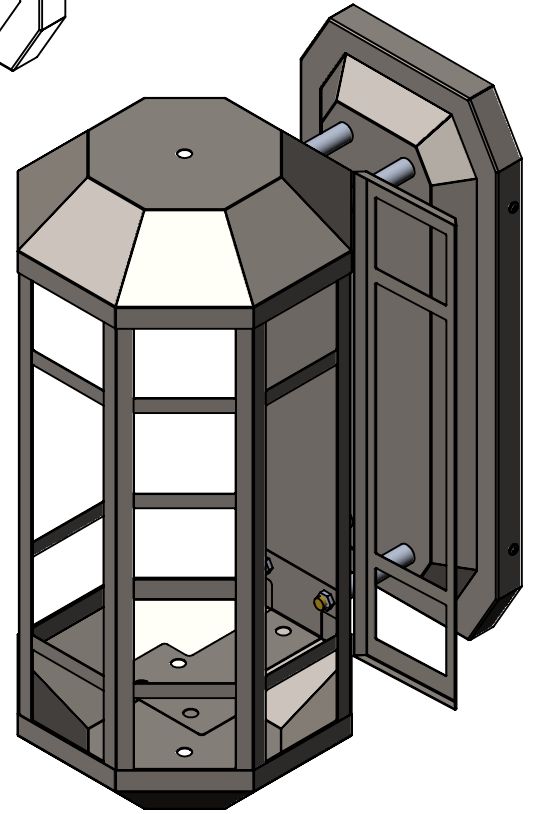
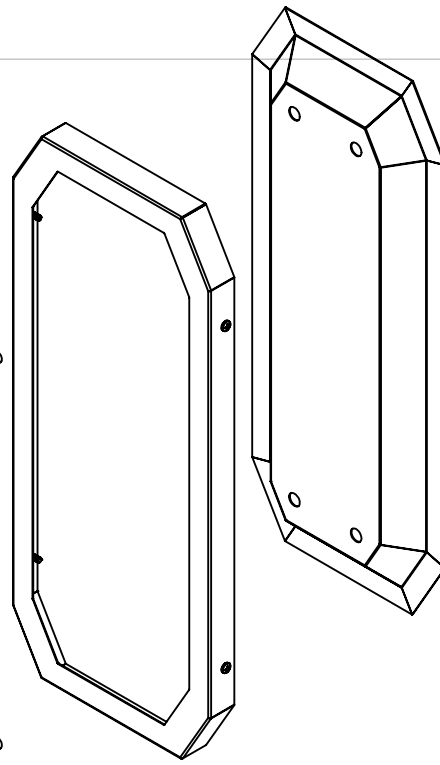
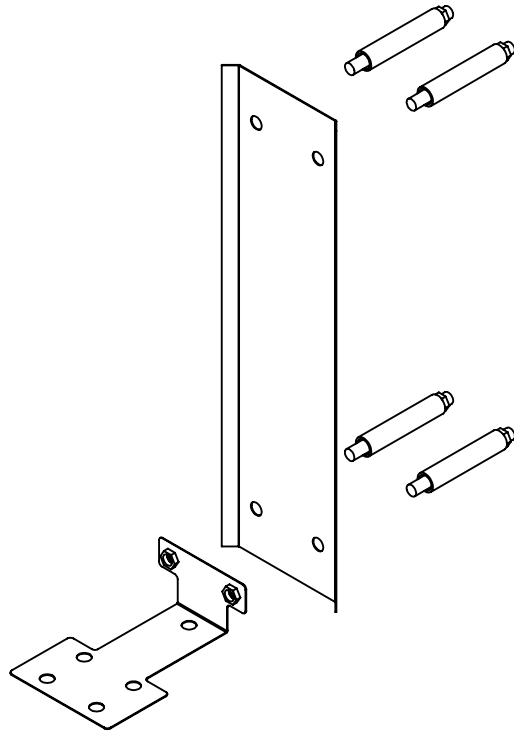
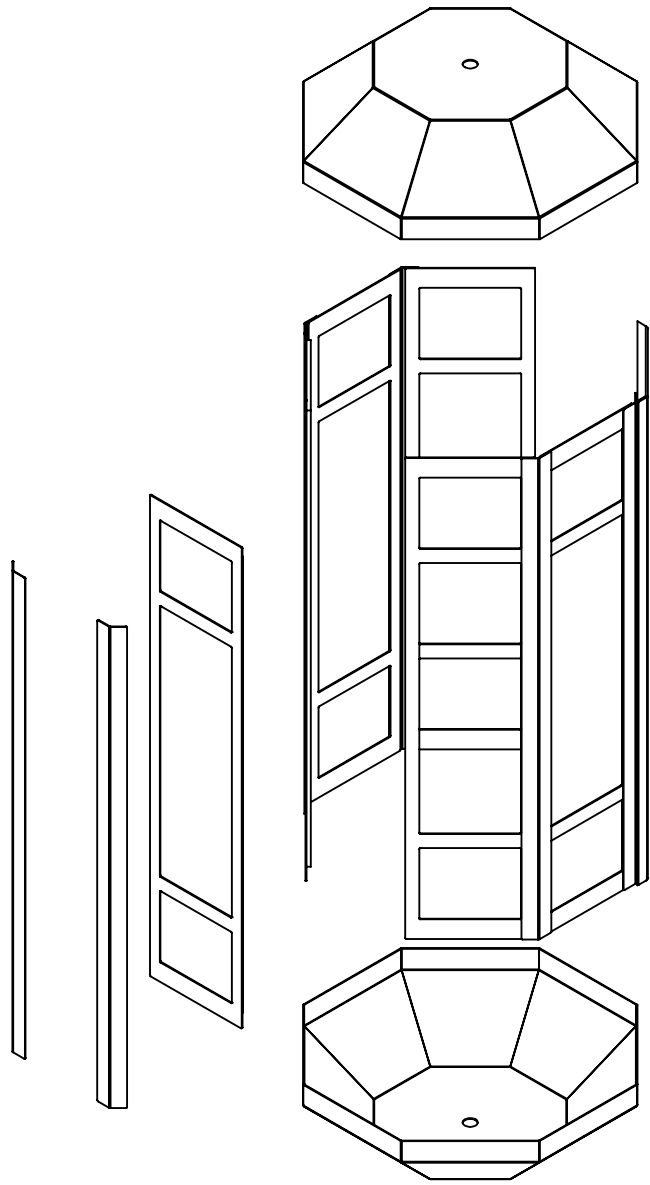

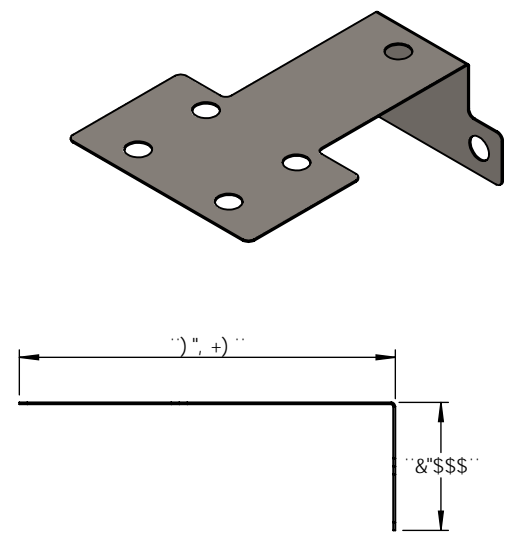
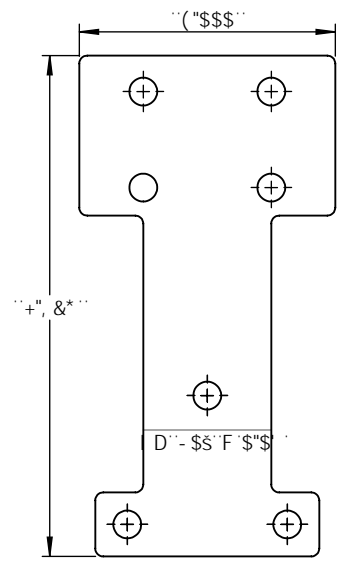
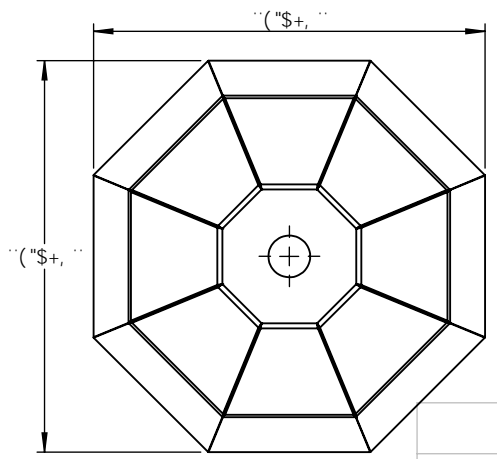
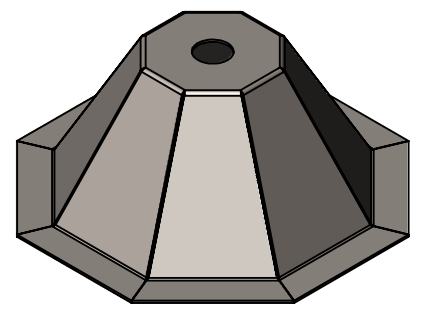
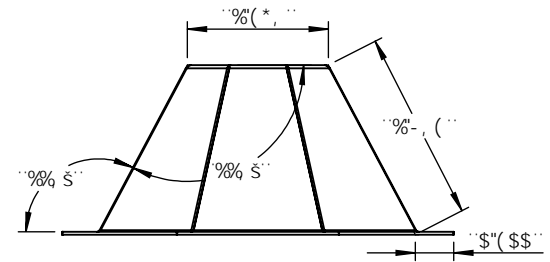
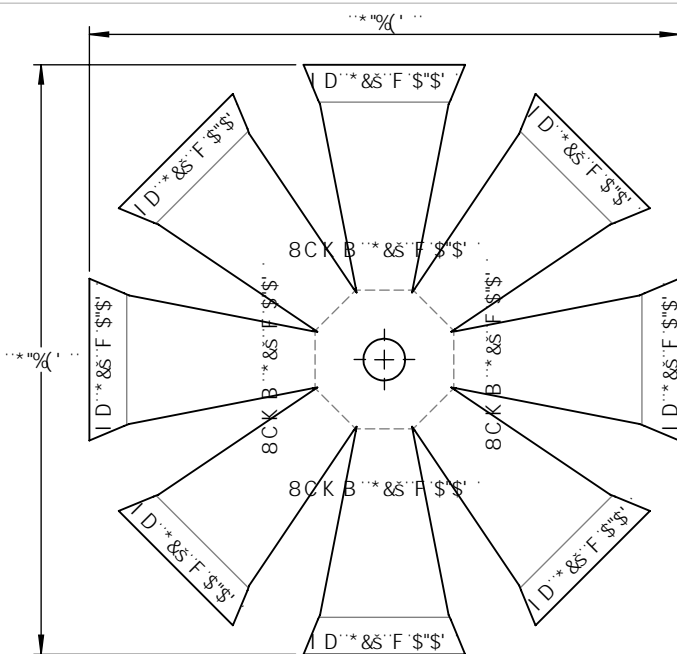

DFC DF-9F5FM5B87CB: 89B H5@
 H: 9 B: CFA 5HC B 7 C B H5 B 98 B H: 6
 8F5K B: 4G H: 9G @ DFC D9F HVC:
 O B G9F H7 C A D5B MB 5A 9 < 9F 92" 5BM
 F9DFC 81 7 HC B -B D5FHCF 5G5 K < C @
 K 4: C1 H: 9K F H9B D9FA 6GC B C:
 O B G9F H7 C A D5B MB 5A 9 < 9F 92 G
 DFC < 6#98"

		I B @GGC H: 9FK 69 GD97 ÷ 98.	B5A 9	85H9	&&; 51; 9 H#@. @B!5A !GDFL&! \$(78@H6?!-!:%\$6
		8-A 9BG@BG5F9-B-B7<9G HC @F5B7 9G :F57 HC B5@± 5B: I @5F: A 57 < ±.....69B8 ± HK C D@579897 A 5@±± H:F99D@579897 A 5@±	8F5K B		
		B:H9FDF9H: 9CA 9F7 HC @F5B7 B: D9F. A 5H9F 5@	9B: 5DDF"		G#9 5 8K; "BC"
B9LH5GGM	I G98 CB	: B@<	A: : 5DDF"	7 C A A 9BHG	
	5DD@7 5HC B	8C B CHG75@98F5K B:	E "5"		G7 5 @. %& K 9 ÷ < H'
					G<99H+C: %

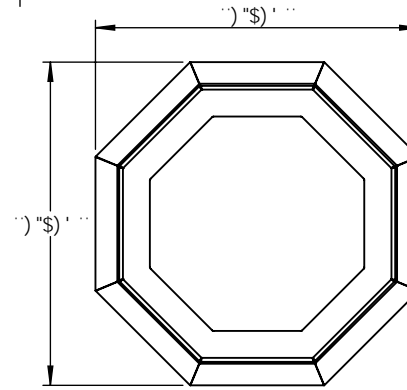
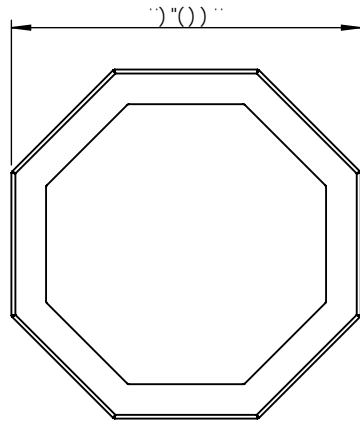
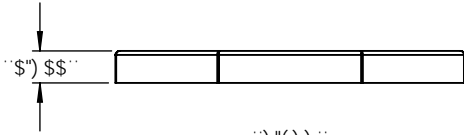
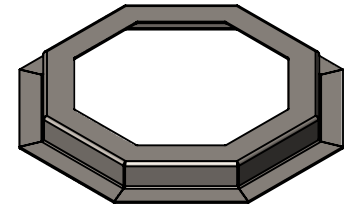
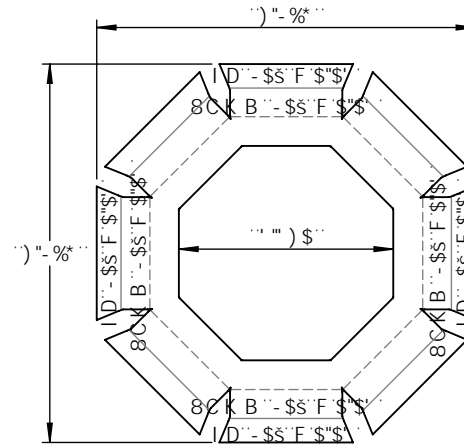
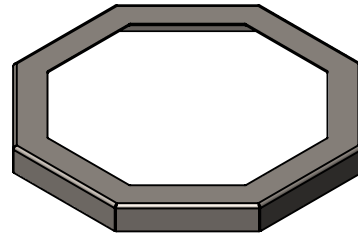
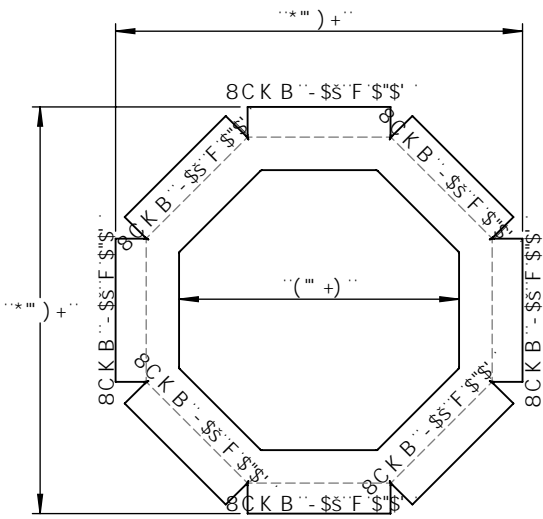

DFC DF 9 5 FM 5 B 8 7 C B : 8 9 B H 5 @
 H: 9 B: CFA 5HC B 7 C B H 5 B 9 B B H: 6
 8F5K B: 6H: 9GC @DFC D9FHMC:
 OBG9FH7CA D5BMB5A 9<9F92" 5BM
 F9DFC 81 7 HC B B D5FHCF 5G5 K <C @
 K H: C1 H: 9K F H: B D9FA 6GC B C:
 OBG9FH7CA D5BMB5A 9<9F92 6
 DFC < 6 H 9 8 "

		I B @GGCH: 9FK 69 GD97 ÷ 98.	B5A 9	85H9	&&; 51; 9
		8 A 9BG C BG5F9 B B7 < 9G HC @F 5B7 9G ; F57 HC B5 @± 5B: I @F: A 57 < ± 69B 8 ± HK C D @ 7 9 8 97 A 5 @ ± H: F99 D @ 7 9 8 97 A 5 @ ±	8F5K B		
		B H F D F 9H: 9C A 9F 7 HC @F 5B7 B: D9F.			@B! 5A !GDFL &! '\$!(7 8 @H6?! -! : %\$6
		A 5 H F 5 @			
	B9LH5GGM	I G98 C B			G A 9 8K; "BC"
	5DD @ 7 5HC B	8C B CHG 7 5 @ 8F5K B:			F9J
					G7 5 @. %' K 9 ÷ < H'
					G < 99H, 'C: %

)

(

&

%

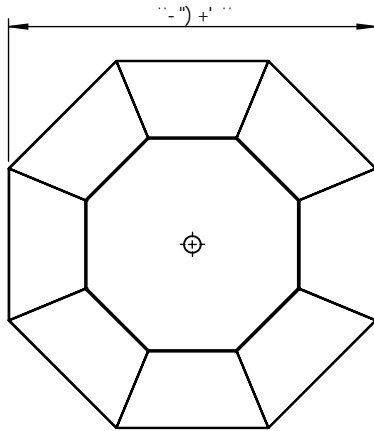
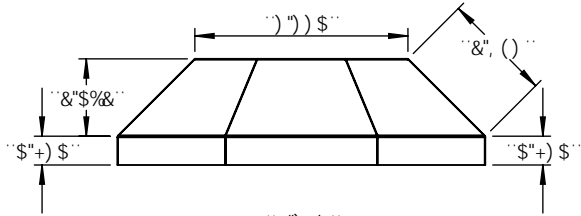
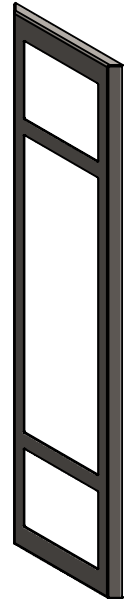
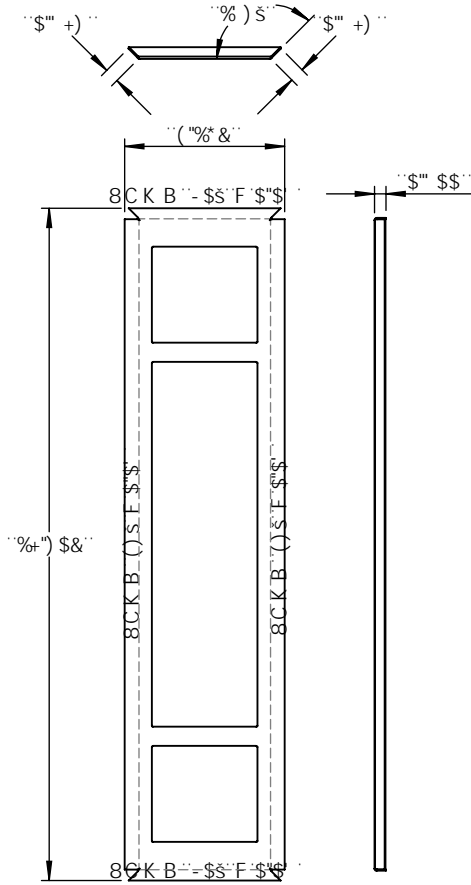
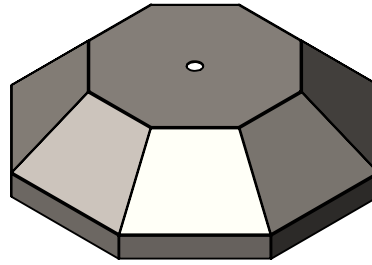
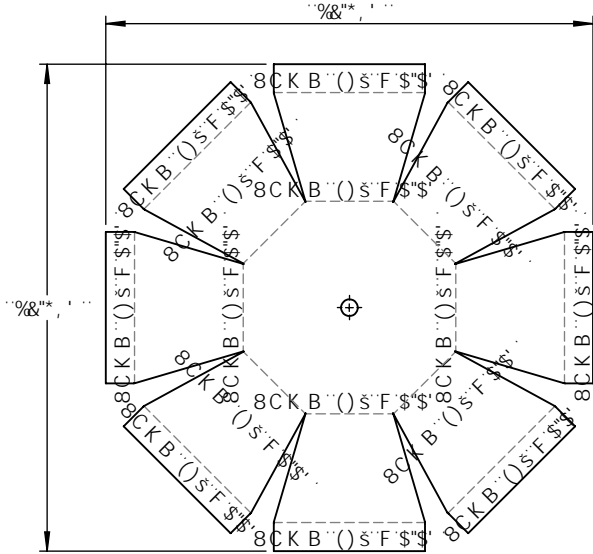

DFC DF 5FM5B87CB: 89BH5@
 H:9 B: CFA 5HC B 7C B15 B98 B H:6
 8F5K B: 6H:9GC @DFC D9FHVC:
 OB G9FH7 CA D5BMB5A 9<9F92" 5BM
 F9DFC 81 7HC B B D5FHCF 5G5 K <C @
 K H:C1 HH:9K F HH9B D9FA 6GC B C:
 OB G9FH7 CA D5BMB5A 9<9F92 6
 DFC <6H98"

B9LH5GGM

I G98 CB

5DD@7 5HC B

I B @GGC H:9FK 69 GD97 ÷ 98.

8 A 9BGC BG5F9 B B7 <9G
 HC @F5B7 9G
 : F57 HC B5 @±
 5B: I @F: A 57 <±69B8 ±
 HK C D @5 7 9 8 97 A 5 @±
 H: F99D @5 7 9 8 97 A 5 @±

B H9FDF 9H: 9C A 9F 7
 HC @F5B7 B: D9F.
 A 5H9F 5@

: B <

8C B CHG7 5 @8F5K B:

B5A 9 85H9

8F5K B
 7 <97 ?98
 9B: 5DDF"
 A: : 5DDF"

E "5"
 7 C A A 9BHG

&&; 51; 9

H#@.

@B!5A !GDFL&! '\$!(7 8@H6?!-!: %\$6

G#9
5

8K; ""BC"

F9J

G7 5 @. %) K 9 ÷ <H'

G<99H- 'C: %

)

(

&

%

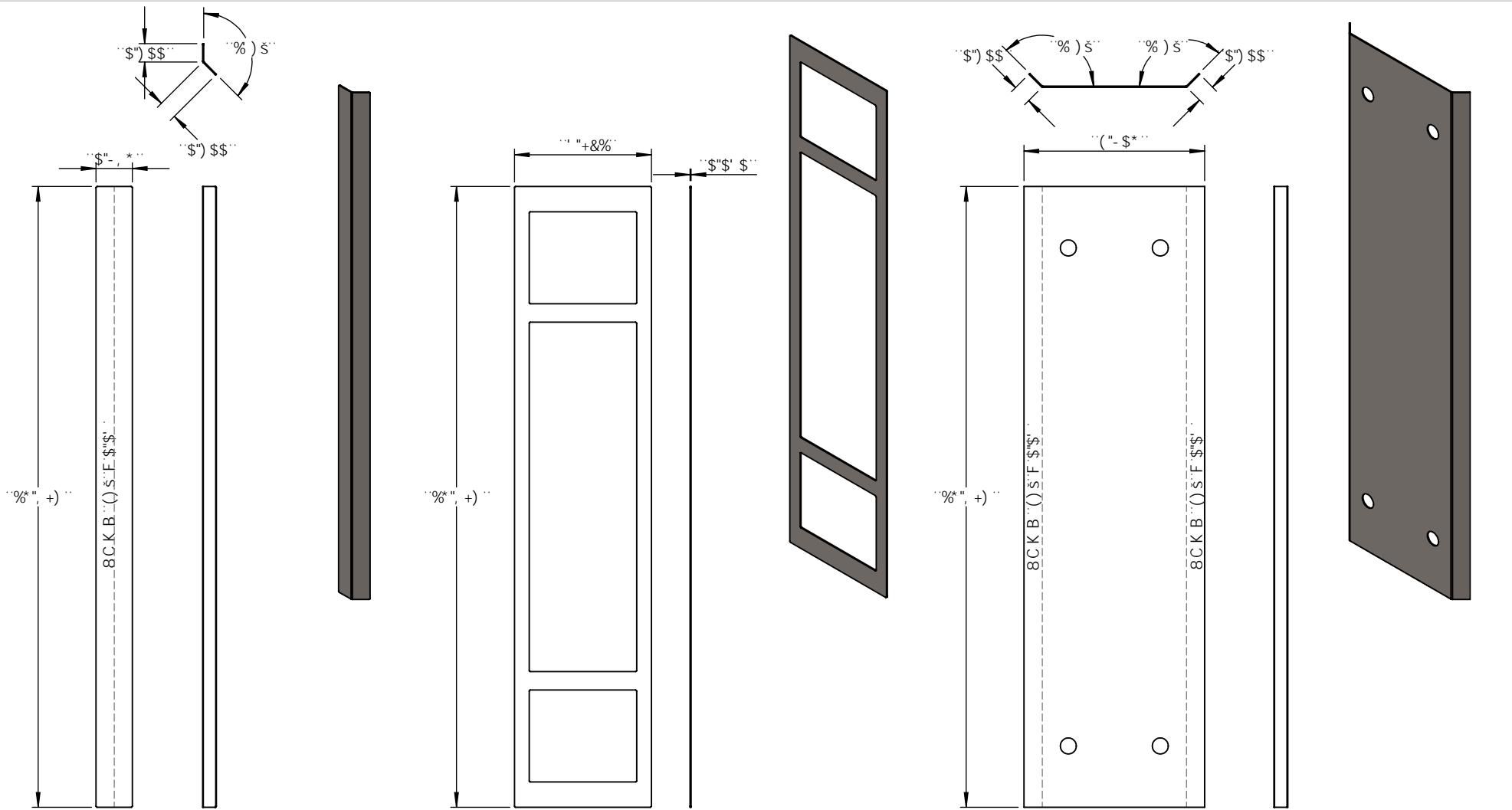

DFC DF 9 5 FM 5 B 8 7 C B : 8 9 B H 5 @
 H: 9 B: C F A 5 H C B 7 C B H 5 B 9 8 B H: 6
 8 F 5 K B: 4 G H: 9 G C @ D F C D 9 F H M C:
 O B G 9 F H 7 C A D 5 B M B 5 A 9 < 9 F 9 2 " 5 B M
 F 9 D F C 8 1 7 H C B B D 5 F H C F 5 G 5 K < C @
 K 4: C 1 H H: 9 K F H 9 B D 9 F A 6 G C B C:
 O B G 9 F H 7 C A D 5 B M B 5 A 9 < 9 F 9 2 G
 D F C < 6 H 9 8 *

		I B @ G G C H: 9 F K 6 9 G D 9 7 ÷ 9 8.	B 5 A 9	8 5 H 9	&& ; 5 1 ; 9
		8 A 9 B G C B G 5 F 9 B B 7 < 9 G H C @ F 5 B 7 9 G : F 5 7 H C B 5 @ ± 5 B: 1 @ 5 F: A 5 7 < ± 6 9 8 8 ± H K C D @ 5 7 9 8 9 7 A 5 @ ± ± H: F 9 9 D @ 5 7 9 8 9 7 A 5 @ ±	8 F 5 K B		
		B H 9 F D F 9 H: 9 C A 9 F 7 H C @ F 5 B 7 B: D 9 F.	7 < 9 7 ? 9 8		@ B ! 5 A ! G D F L & ! ' \$! (7 8 @ H 6 ? ! - ! : % \$ 6
		A 5 H 9 F 5 @	9 B: 5 D D F "		
	B 9 L H 5 G G M	I G 9 8 C B	A: : 5 D D F "		G A 9 8 K ; " " B C " F 9 J
	5 D D @ 7 5 H C B	8 C B C H G 7 5 @ 9 8 F 5 K B:	E " 5 "		
			7 C A A 9 B H G		G 7 5 @ . % (K 9 ÷ < H ' G < 9 9 H % \$ C : %

)

(

&

%

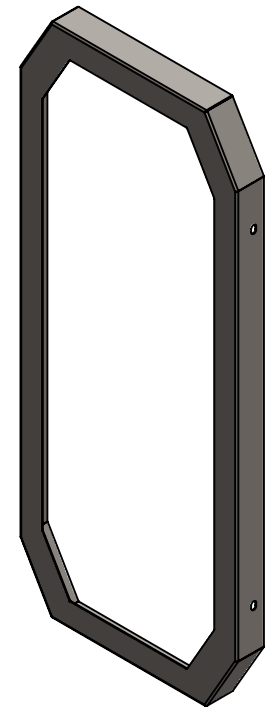
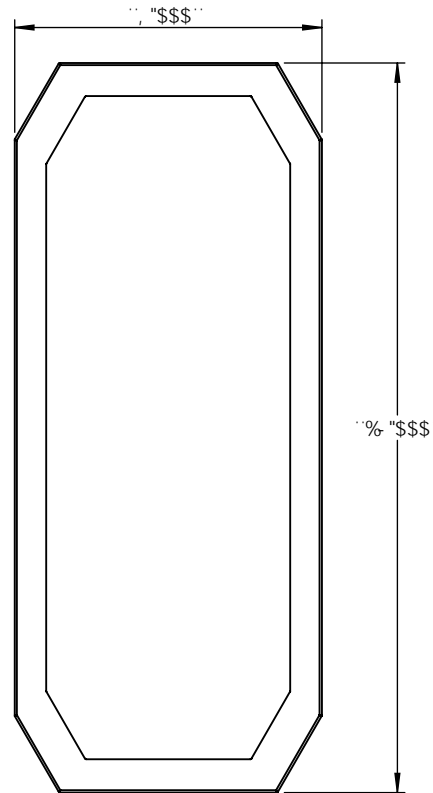
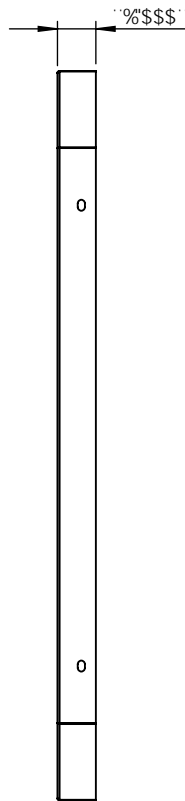
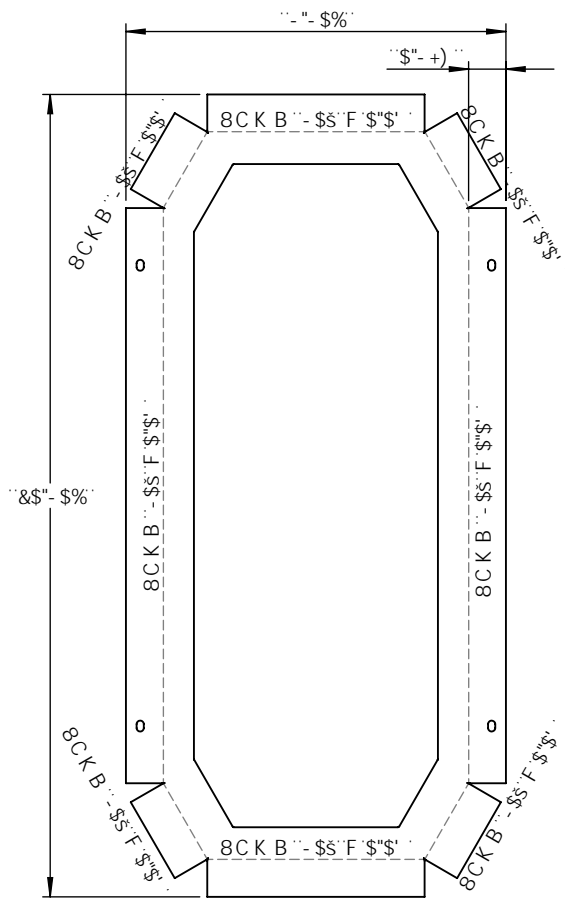

DFC DF 9 5 FM 5 B 8 7 C B : 8 9 B H 5 @
 H: 9 B: CFA 5HC B 7 C B H 5 B 98 B H: 6
 8F5K B: 6H: 9GC @DFC D9FHMC:
 OB G9FH7 CA D5BMB 5A 9 < 9F 92" 5BM
 F9DFC 81 7 HC B B D5FHCF 5G5 K < C @
 K H: C1 H H: 9K F H H B D9FA 6GC B C:
 OB G9FH7 CA D5BMB 5A 9 < 9F 92 G
 DFC < 6 H 98"

		I B @GGC H: 9FK 69 GD97 ÷ 98.		B5A 9	85H9	&&; 51; 9		
		8 A 9BG C BG5F9 B B7 < 9G HC @F 5B7 9G : F57 HC B5 @± 5B: I @F: A 57 < ± 69B 8 ± HK C D @5 7 9 8 97 A 5 @ ± H: F99 D @5 7 9 8 97 A 5 @ ±	8F5K B 7 < 97 ? 98 9B: 5DDF" A: : 5DDF"			H#@.		
		B H F D F 9H: 9C A 9F 7 HC @F 5B7 B: D9F. A 5 H F 5 @	E "5" 7 C A A 9BHG			@B! 5A !GDFL &! \$(7 8 @H 6?! -! : %\$6		
B9LH5GGM	I G98 C B	: B 6<				G A 9 5 8K; ""BC"	F9J	
5DD @ 7 5HC B		8C B CHG 7 5 @ 8F5K B:				G 7 5 @. %)	K 9 ÷ < H'	G < 99H % % C : %

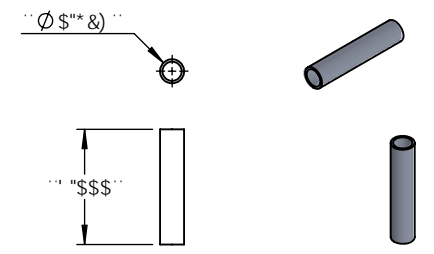
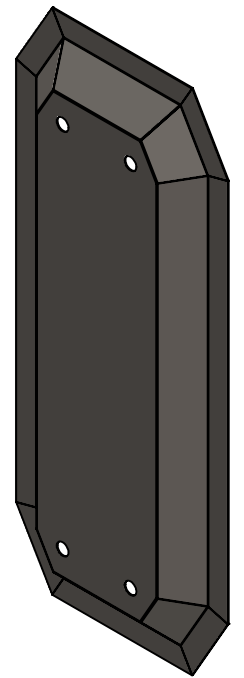
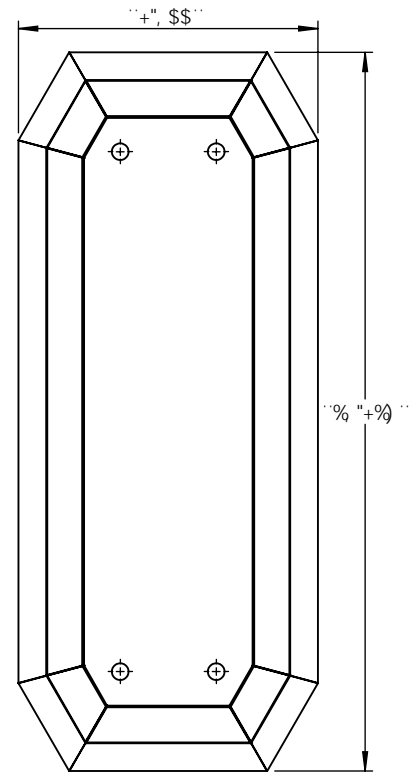
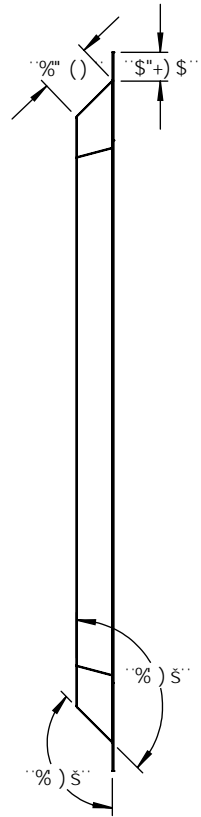
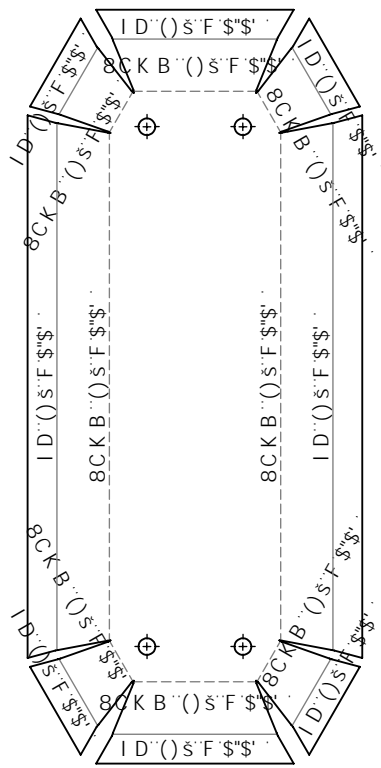

DFC DF 5 FM 5 B 8 7 C B : 8 9 B H 5 @
 H: 9 B: CFA 5HC B 7 C B H 5 B 9 B B H: 6
 8F5K B: 6H: 9GC @DFC D9F HVC:
 O B G 9 F H 7 C A D 5 B M B 5 A 9 < 9 F 9 2 " 5 B M
 F 9 D F C 8 1 7 H C B B D 5 F H C F 5 G 5 K < C @
 K H: C 1 H H: 9 K F H 9 B D 9 F A 6 G C B C:
 O B G 9 F H 7 C A D 5 B M B 5 A 9 < 9 F 9 2 G
 D F C < 6 H 9 8 "

		I B @ G G C H: 9 F K 6 9 G D 9 7 ÷ 9 8.		B 5 A 9	8 5 H 9	&& ; 5 1 ; 9		
		8 A 9 B G C B G 5 F 9 B B 7 < 9 G H C @ F 5 B 7 9 G ; F 5 7 H C B 5 @ ± 5 B: 1 @ F: A 5 7 < ± 6 9 B 8 ± H K C D @ 5 7 9 8 9 7 A 5 @ ± H: F 9 9 D @ 5 7 9 8 9 7 A 5 @ ±	8 F 5 K B 7 < 9 7 ? 9 8 9 B: 5 D D F" A: ; 5 D D F"					H # @.
		B H F D F 9 H: 9 C A 9 F 7 H C @ F 5 B 7 B: D 9 F. A 5 H F 5 @	E " 5" 7 C A A 9 B H G			@ B ! 5 A ! G D F L & ! ' \$! (7 8 @ H 6 ? ! - ! : % \$ 6		
B 9 L H 5 G G M	I G 9 8 C B	: B <				G A 9	8 K ; " " B C "	F 9 J
	5 D D @ 7 5 H C B	8 C B C H G 7 5 @ 8 F 5 K B:				5		
						G 7 5 @ . %)	K 9 ÷ < H '	G < 9 9 H % & C : %

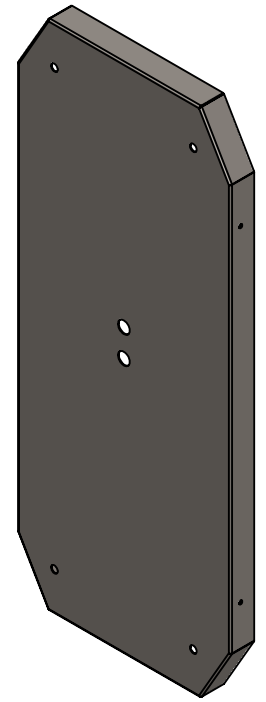
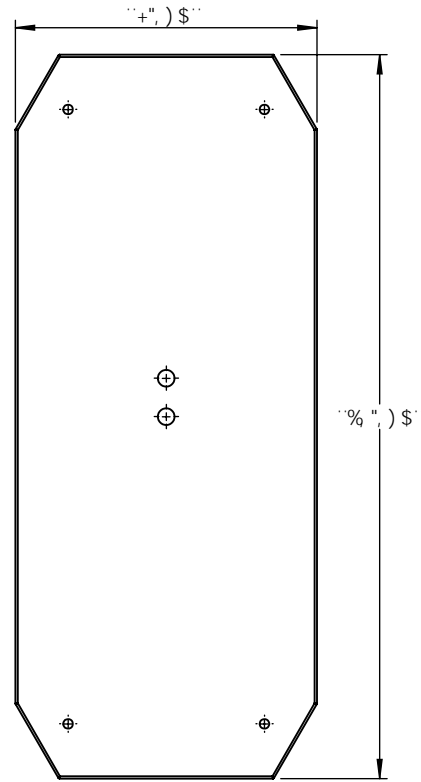
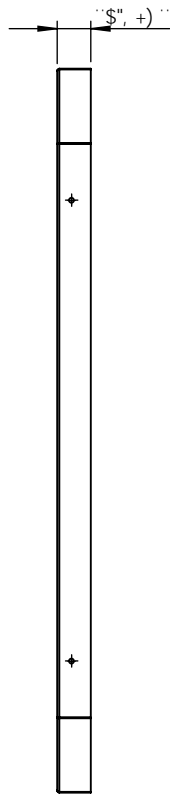
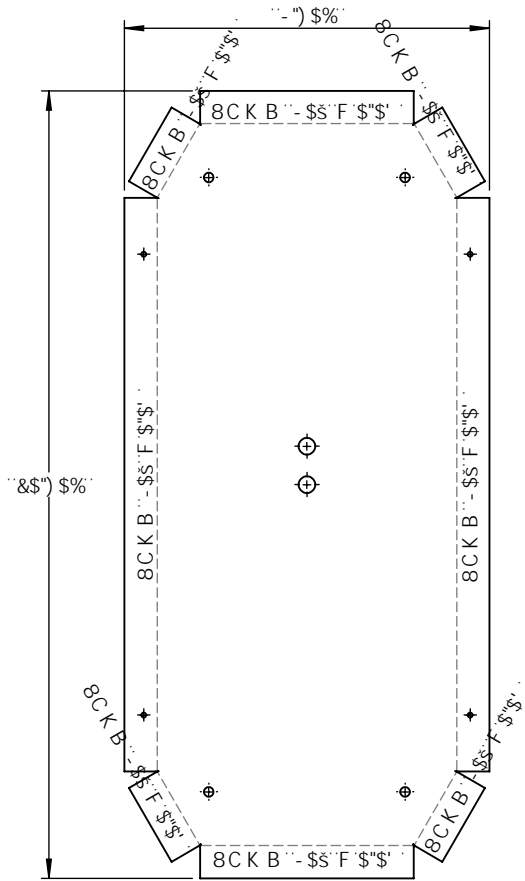

DFC DF 5FM5B87CB: 89BH5@
 H:9 B: CFA 5HC B 7 C B H5 B 98 B H:6
 8F5K B: 4GH:9GC @DFC D9F HMC:
 OBG9FH7 CA D5BMB5A 9<9F92" 5BM
 F9DFC 81 7 HC B B D5FHCF 5G5 K <C @
 K H:C1 H:9K F H9B D9FA 6GC B C:
 OBG9FH7 CA D5BMB5A 9<9F92 4
 DFC <6H98"

		I B @GGC H:9FK 69 GD97 ÷ 98.	B5A 9	85H9	&&; 51; 9
		8 A 9BG C BG5F9 B B7 <9G HC @F5B7 9G ; F57 HC B5 @± 5B: I @F: A 57 <±69B8 ± HK C D @57 9897 A 5 @± H:K99D @57 9897 A 5 @±	8F5K B		
		B H9FDF 9H: 9C A 9FF 7 HC @F5B7 B: D9F.	9B: 5DDF"		@B!5A !GDFL&! '\$!(7 8@H6?!-!:%\$6
		A 5H9F 5@	A: 5DDF"		
		: B H9F 5@	E "5"		
			7 C A A 9BHG		
B9LH5GGM	I G98 CB	: B H9F 5@			G A 9 8K; ""BC" F9J
5DD@7 5HC B		8C B CHG7 5 @98F5K B:			G7 5 @.%) K 9 ÷ <H' G<99H% 'C: %

)

(

&

%