

**EVERGREEN LIGHTING**

<p>5 @ 69B8 F58 + G "\$" \$"</p>	<p>I B @GGC H: 9FK 69 GD97 ÷ 98.          8 A 9BG C BG5F9 B B7 &lt; 9G          HC @F 5B7 9G          : F57 HC B5 @ ± "\$"          5B: I @5F: A 57 &lt; ± "\$%" 69B8 ±          HK C D @5 7 9 8 97 A 5 @ ± "\$"          H: F99D @5 7 9 8 97 A 5 @ ± "\$"</p>	<p>B5A 9 85H9</p>	<p>8F5K B          7 &lt; 97 ? 98          9B: 5DDF"          A: 5DDF"          E "5"          7 C A A 9BHG</p>	<p>H @.</p> <p>5G &lt; !6! (' m f % &amp; K ! 5 ! H 6 F ! K : ! ' \$ ?</p>
<p>5DD @ 7 5HC B</p>	<p>8C B CHG 7 5 @ 98F5K B:</p>			<p>G A 9 8K ; "" BC "</p> <p><b>5</b> H 7 ? 9 H &amp; ' ' ( -</p> <p>F9J</p> <p>G 7 5 @ . % % \$ K 9 ÷ &lt; H '</p> <p>G &lt; 99 H % C : % &amp;</p>

) ( ) & %

#PA 'BC "	D5FHBI A 69F	89G7 F-DHC B	E HM	7 I H
%	5G<!6!( ' m%&k !5!H6F!K :!' \$?!5B7 <CF D@5H9	5@ A -BI A '\$')\$\$"D@5H9	%	
&	5G<!6!( ' m%&k !5!H6F!K :!' \$?!5B7 <CF H56	5@ A -BI A '\$')\$\$"D@5H9	(	
'	5G<!6!( ' m%&k !5!H6F!K :!' \$?!<958	5@ A -BI A '\$\$**)"	%	
(	5G<!6!( ' m%&k !5!H6F!K :!' \$?!<958 7CJ 9F	5@ A -BI A '\$\$**)"	%	
)	5G<!6!( ' m%&k !5!H6F!K :!' \$?!G DDC FH6F57?9H	5@ A -BI A '\$\$**)"	%	
*	5G<!6!( ' m%&k !5!H6F!K :!' \$?!<958 657? -BB 9F D@5H9	5@ A -BI A '\$\$**)"	%	
+	5G<!6!( ' m%&k !5!H6F!K :!' \$?!<958 657?D@5H9	5@ A -BI A '\$\$**)"	%	
,	5G<!6!( ' m%&k !5!H6F!K :!' \$?!6C 8M	5@ A -BI A '\$\$**)"	%	
-	5G<!6!( ' m%&k !5!H6F!K :!' \$?!GF 1 7H F9'6F57?9H	5@ A -BI A '\$\$**)"	&	
%\$	5G<!6!( ' m%&k !5!H6F!K :!' \$?!6C 8M657? -BB 9F D@5H9	5@ A -BI A '\$\$**)"	%	
%%	5G<!6!( ' m%&k !5!H6F!K :!' \$?!6C 8M657?D@5H9	5@ A -BI A '\$\$**)"	%	
%&	5G<!6!( ' m%&k !5!H6F!K :!' \$?!A C I BHB; '6F57?9H	5@ A -BI A '\$\$**)"	%	
%	5G<!6!( ' m%&k !5!H6F!K :!' \$?!57 FM@7	57 FM@7	%	
%('	?H@8!&)!%+\$! : 8 -A !5: (	8F 7 9F	%	
%)	5 'U' @98 SDB %\$\$(FY j 8	@98	&	

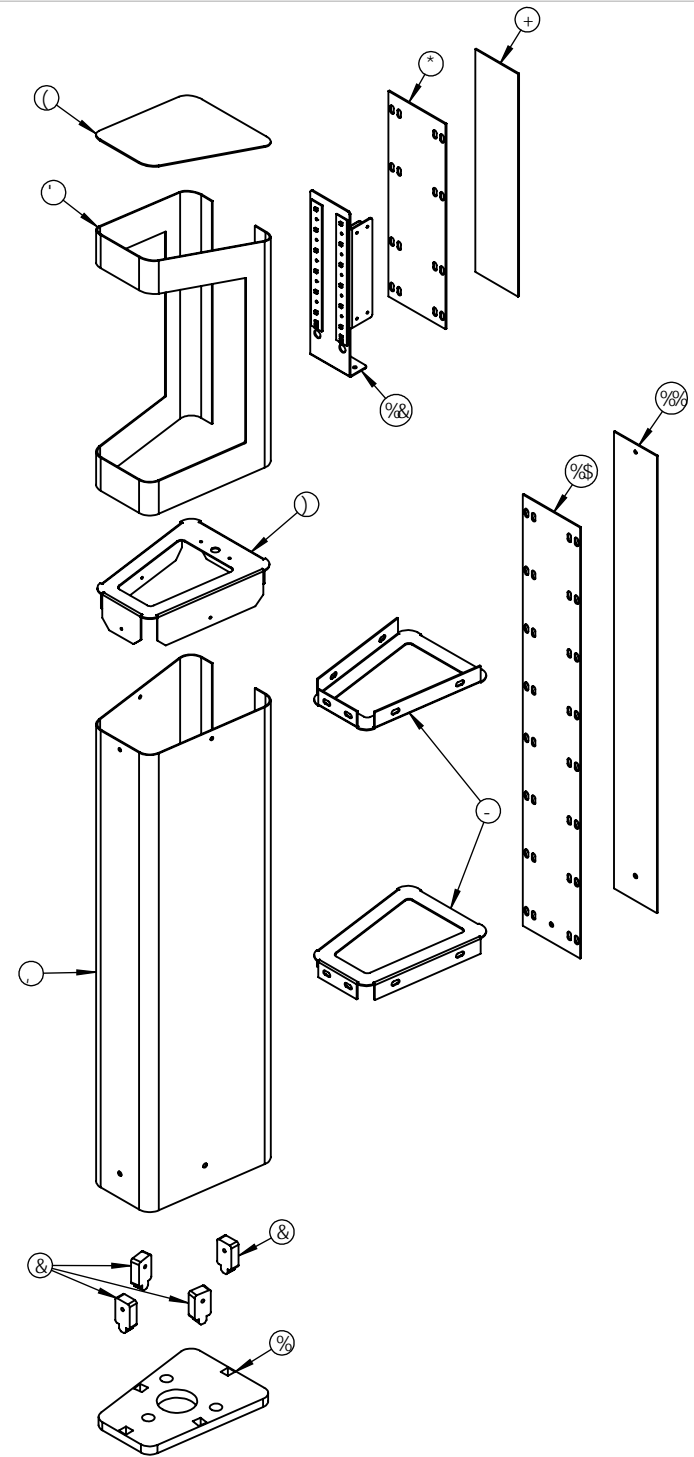

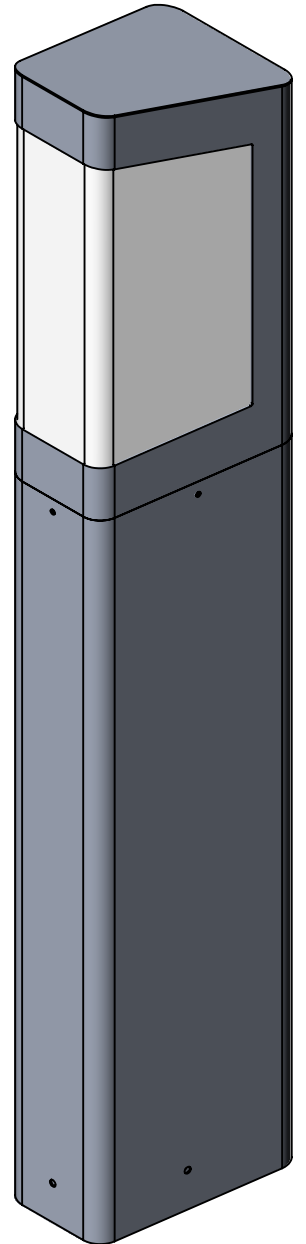
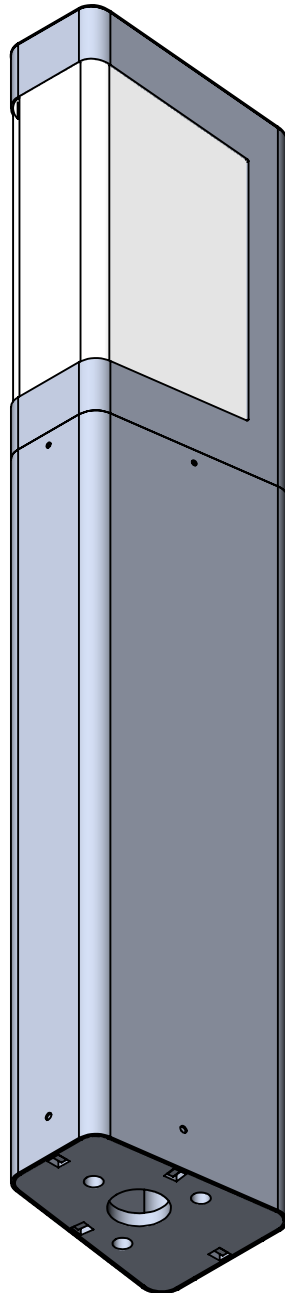
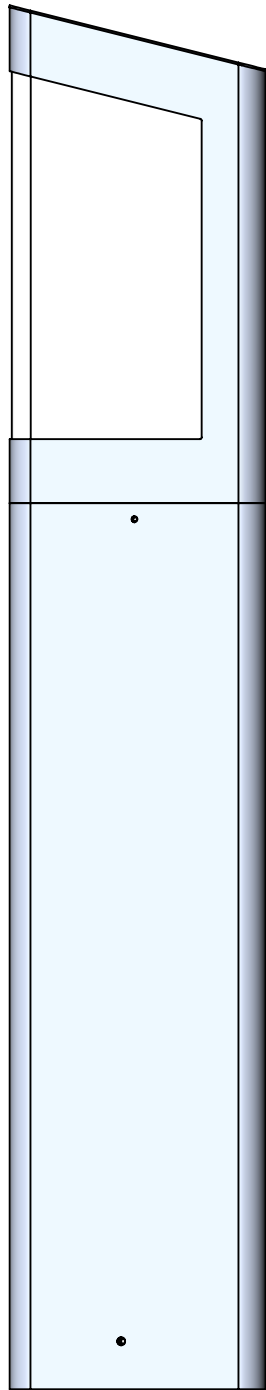
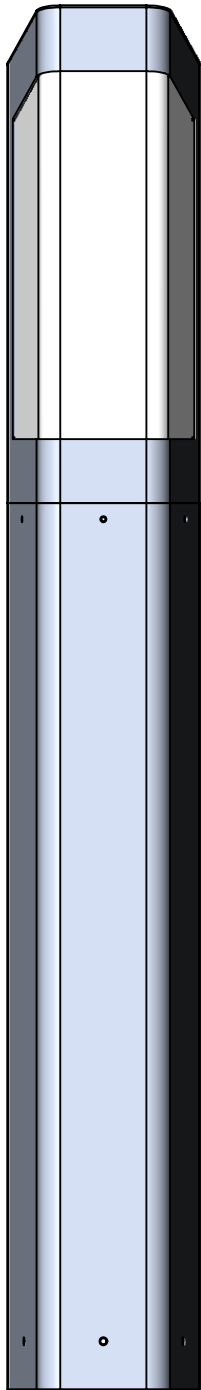

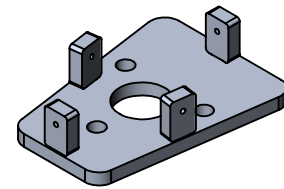
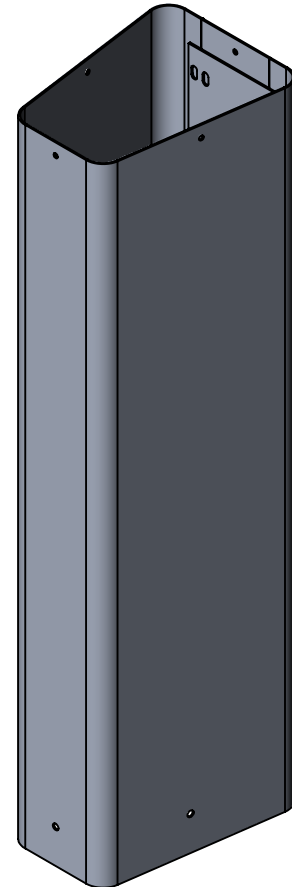
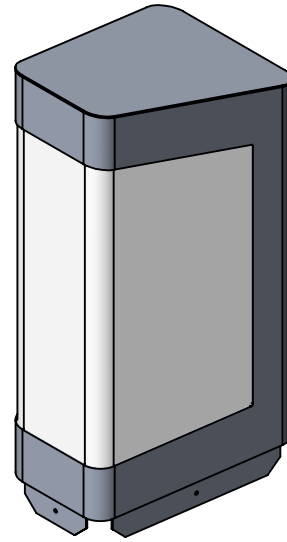
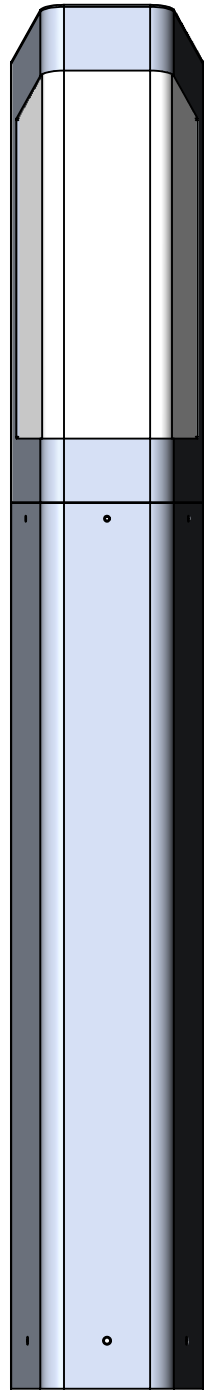

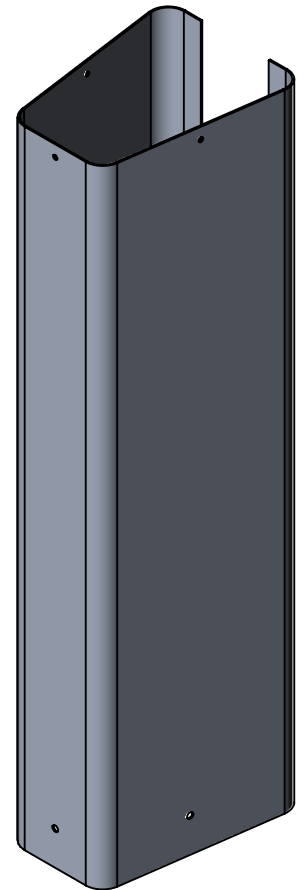
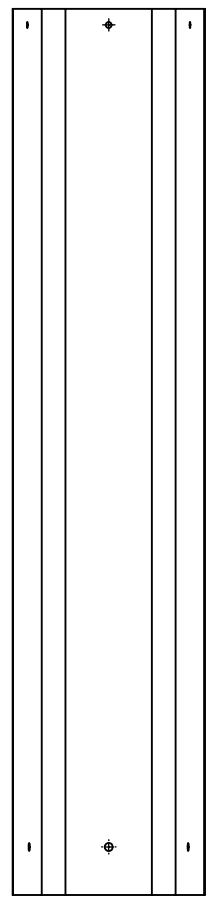
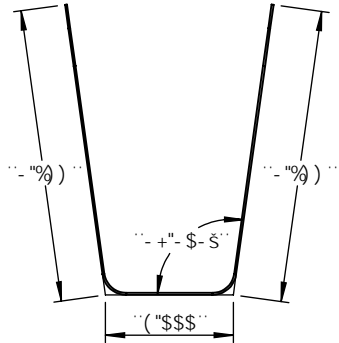
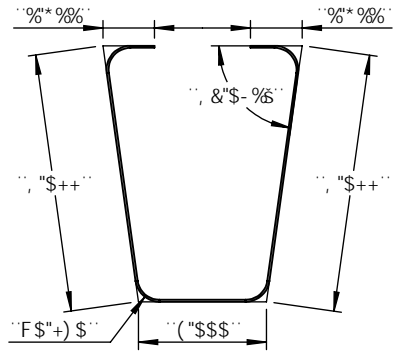
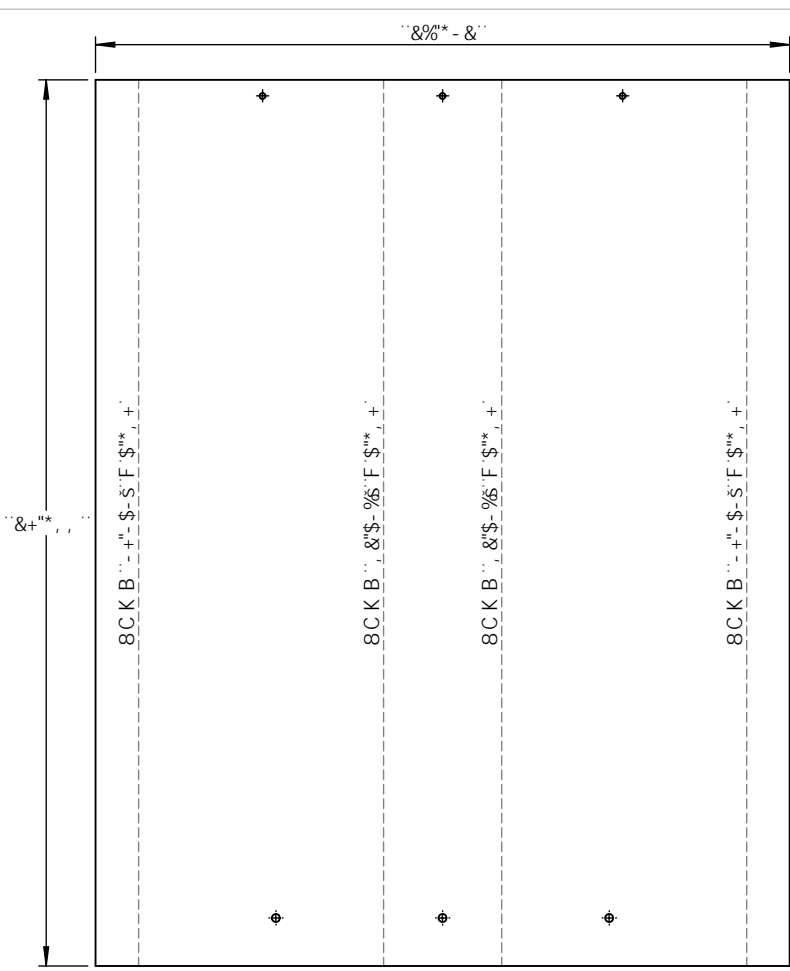

DFC DF 5 FM 5 B 8 7 C B: 8 9 B H 5 @  
 H: 9 B: CFA 5HC B 7 C B H 5 B 98 B H: 6  
 8F5K B: 6H: 9GC @DFC D9FHVC:  
 OBG9FH7CA D5BMB5A 9<9F92" 5BM  
 F9DFC 81 7HC B-B D5FHCF 5G5 K <C @  
 K H: C1 H: 9K F H: 9B D9FA 6GC B C:  
 OBG9FH7CA D5BMB5A 9<9F92 6  
 DFC <6H98"

B9LH5GGM I G98 C B  
 5DD@7 5HC B

I B @GGCH: 9FK 69GD97 ÷ 98.  
 8A 9BG C BG5F9 B B7 <9G  
 HC @F5B7 9G  
 : F57HC B5 @±  
 5B: I @5F: A 57 <± ..... 69B 8 ±  
 HC C D @5 7 9 8 97 A 5 @ ± ±  
 H: F99D @5 7 9 8 97 A 5 @ ±  
 B H: FDF 9H: 9CA 9FF 7  
 HC @F5B7 B: D9F.  
 A 5H: F 5 @  
 : B 6<  
 8C B CHG7 5 @ 8F5K B:

	B5A 9	85H9
8F5K B		
7 < 97 ? 98		
9B: 5DDF"		
A: : 5DDF"		
E "5"		
7 C A A 9BHG		

5 @ A B I A '\$\$\*' ) "  
 H @.  
 5G < ! 6 ! ( ' m i 9 & K ! 5 ! H 6 F ! K ! : ' \$ ?  
 G A 9 8 K ; " " B C " F 9 J  
 5  
 G 7 5 @ . % \* K 9 ÷ < H ' G < 9 9 H ) ' C : % &

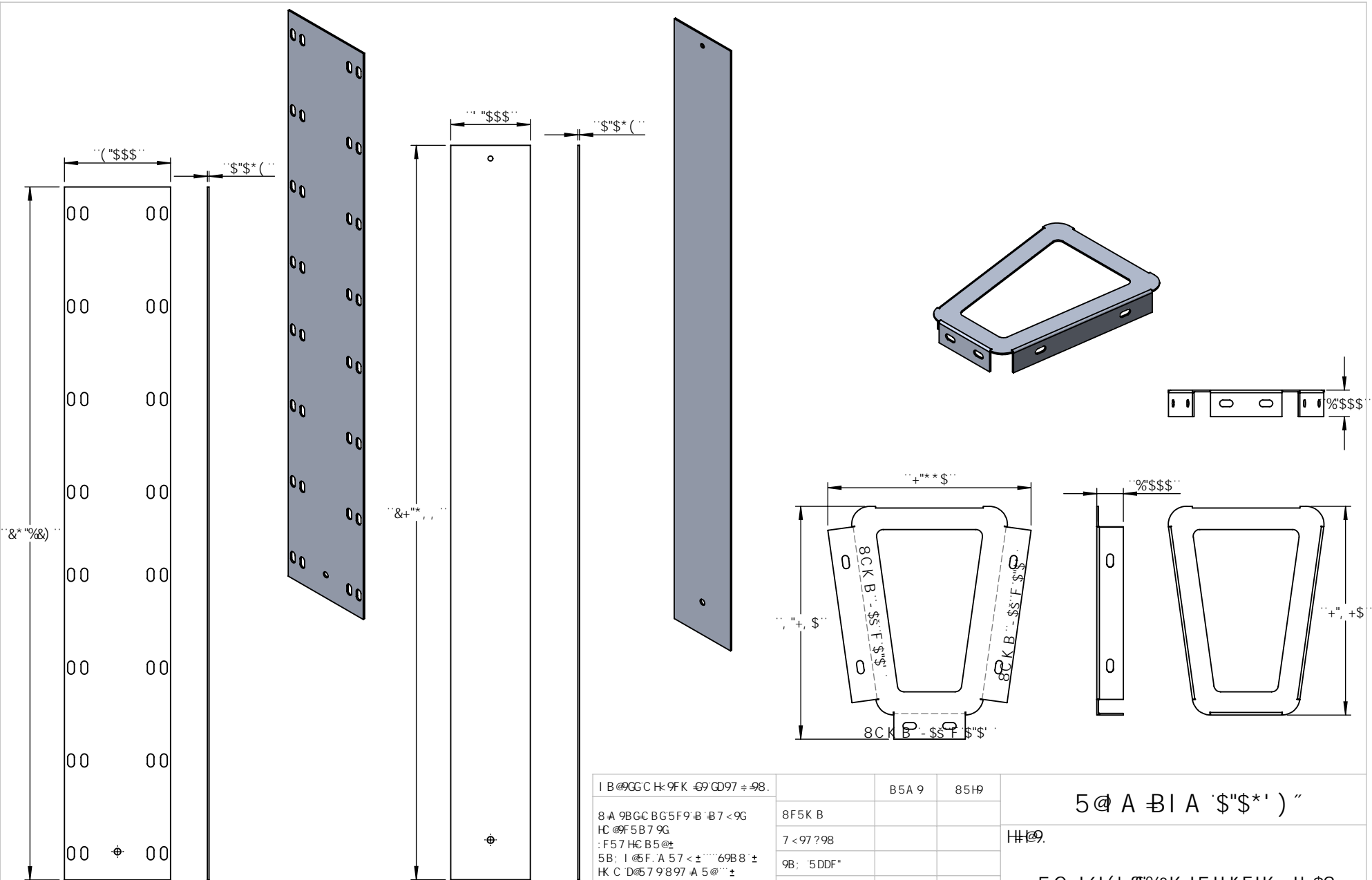

I B @GGCH: 9FK 69 GD97 ÷ 98.  
 8A 9BGĈ BG5F9-B 7<9G  
 HC @F5B7 9G  
 : F57 HC B5@±  
 5B: I @5F: A 57 <± .....69B8 ±  
 HK C D@57 9897 A 5@±  
 HKF99D@57 9897 A 5@±

BHFDF9H: 9CA 9FF 7  
 HC @F5B7 B: D9F.  
 A 5HF 5@  
 : BĈ<

B5A 9 85H9  
 8F5K B  
 7<97 798  
 9B: 5DDF"  
 A: 5DDF"  
 E "5"  
 7 C A A 9BHG

5 @ A BIA '\$\$\*' ) "  
 H#@.  
 5G<!6!( ' m!%&K !5!HBF!K :!' '\$?  
 G#9 8K ; ""BC" F9J  
 5  
 G7 5 @. %) K 9 ÷ <H' G<99H\* ' C : %&

DFC DF 5FM5B8 7CB: 89BH5@  
 H: 9 B: CFA 5HC B 7 C B H5 B 98 B H: 6  
 8F5K B: 6H: 9 GC @DFC D9FHVC:  
 OBG9FH7 CA D5BMB5A 9<9F92" 5BM  
 F9DFC 81 7 HC B B D5FHCF 5G5 K <C @  
 K H: C I H: 9K F H9B D9FA ĈGC B C:  
 OBG9FH7 CA D5BMB5A 9<9F92 Ĉ  
 DFC <6#98"

B9LH5GGM I G98 CB  
 5DD@7 5HC B  
 8C B CHG7 5 @ 8F5K B:

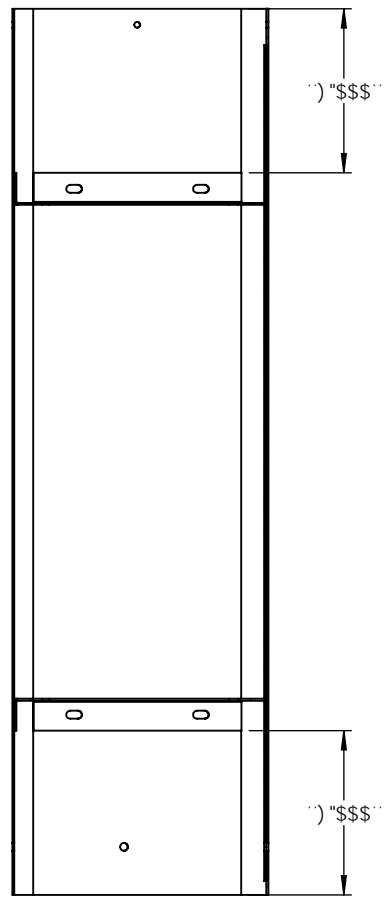
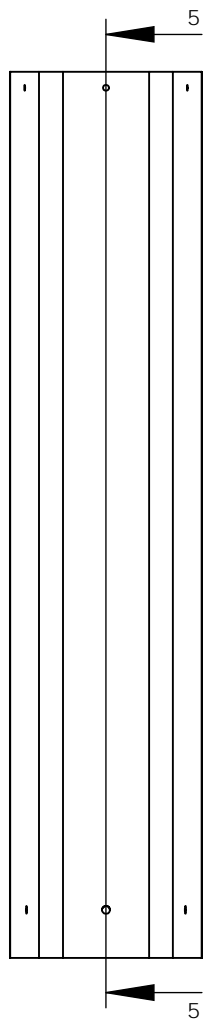

G97 HC B '5!5

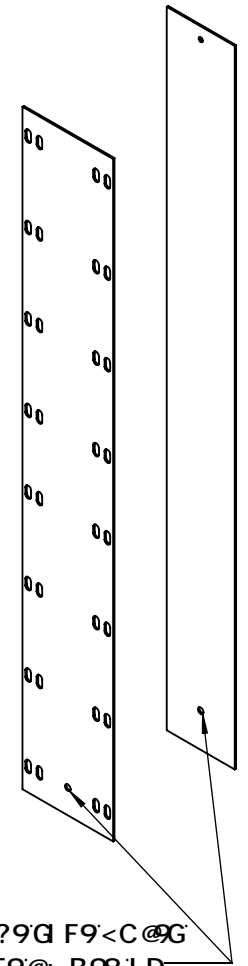
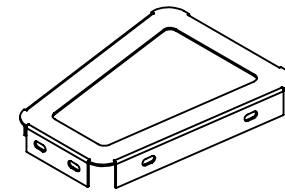
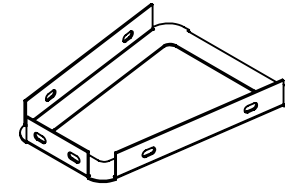
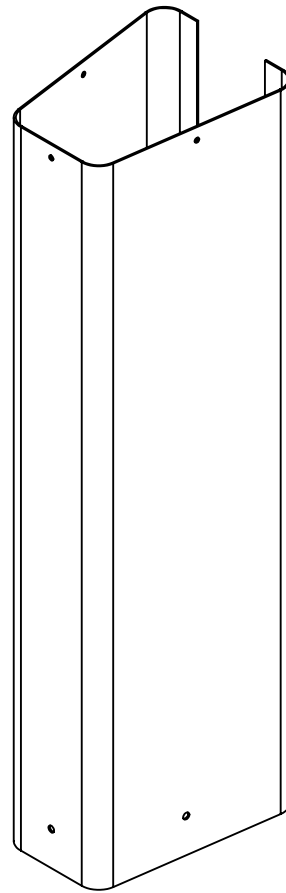

A 5?9G F9<C@G  
5F9@ B98!D

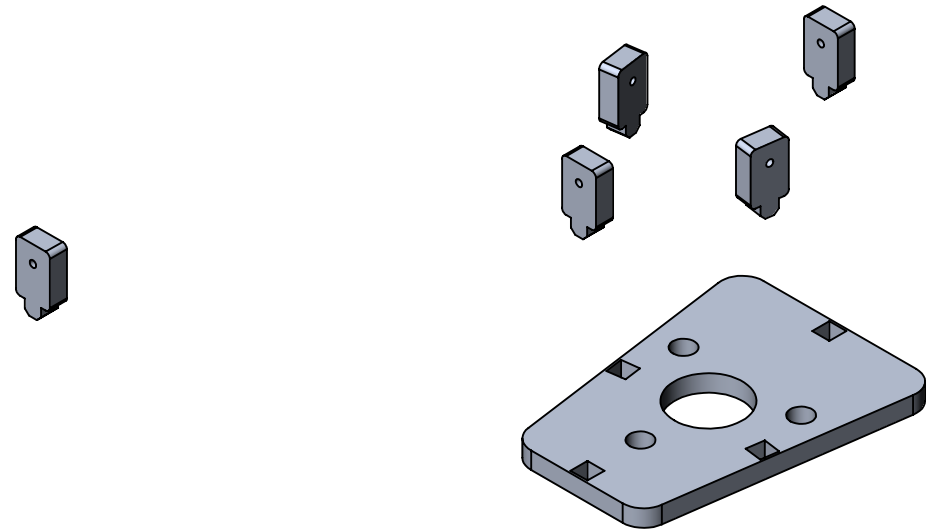
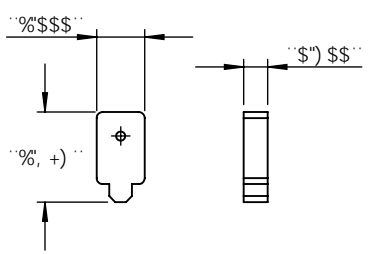
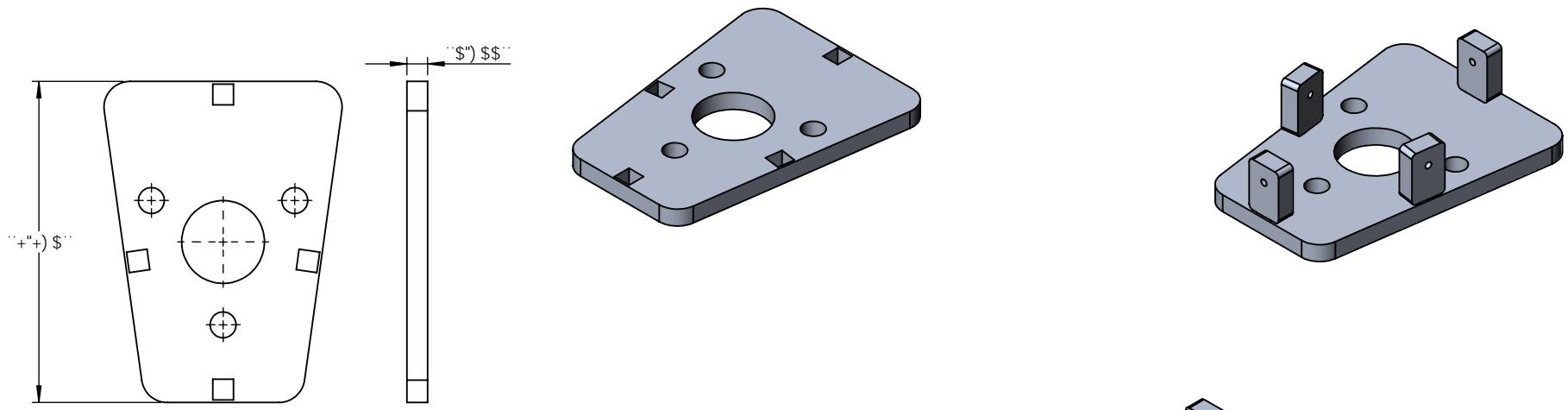

DFC DF-5FM5B87CB: 89BH5@  
 H:9 B: CFA 5HC B 7 C B H5 B 98 B H:6  
 8F5K B: 4GK:9GC @DFC D9FHMC:  
 OBG9FH7CA D5BMB5A 9<9F92" 5BM  
 F9DFC 81 7 HC B B D5FHCF 5G5 K <C @  
 K H:C1 H:K:9K F H9B D9FA 6GC B C:  
 OBG9FH7CA D5BMB5A 9<9F92 6  
 DFC <6#98"

		I B @GGCH:9FK 69GD97 ÷ 98.	B5A 9	85H9	5 @ A B I A '\$') \$\$"D@5H9
		8 A 9BG C BG5F9 B B7 <9G HC @F5B7 9G : F57 HC B5 @± 5B: I @5F: A 57 <± .....69B8 ± HK C D@579897 A 5@± H:K F99D@579897 A 5@±	8F5K B		H#@.
		B H9FDF9H: 9C A 9FF 7 HC @F5B7 B: D9F.	7 <97 ?98		5G<!6!( ' m!9&K !5!H6F!K :!' \$?
		A 5H9F 5@	9B: 5DDF"		
			A: : 5DDF"		
			E "5"		
			7 C A A 9BHG		
B9LH5GGM	I G98 C B	: B 6<			G#9 8K ; ""BC" F9J
5DD@7 5HC B	8C B CHG75@98F5K B:				G7 5 @. % ( K 9 ÷ <H' G<99H, 'C: '%&



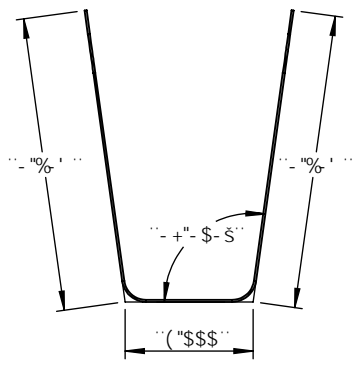
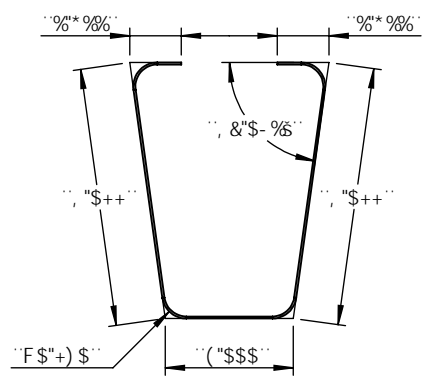
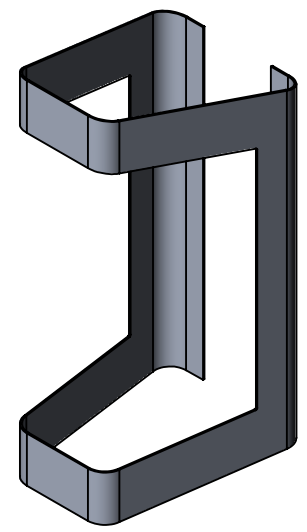
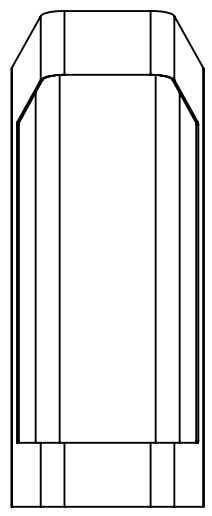
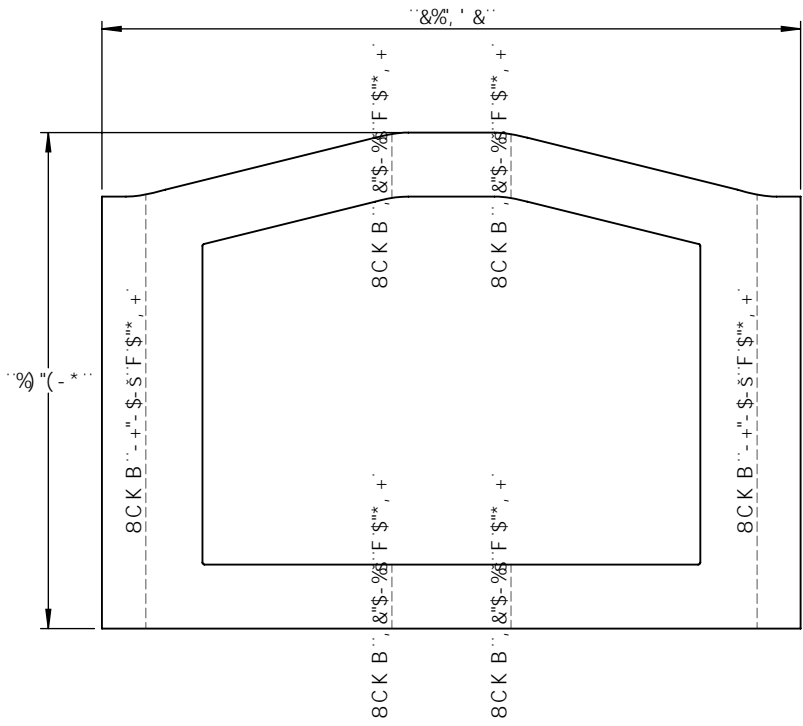

DFC DF-5FM5B87CB: 89BH5@  
 H:9 B: CFA 5HC B 7C B15 B98 B H:6  
 8F5K B: 6H:9GC @DFC D9FHC:  
 OBG9FH7CA D5BMB5A 9<9F92" 5BM  
 F9DFC 81 7HC B-B D5FHC F 5G5 K <C @  
 K 4: C1 H:9K F H9B D9FA 6GC B C:  
 OBG9FH7CA D5BMB5A 9<9F92 6  
 DFC <6#98"

B9LH5GGM I G98 CB  
 5DD@7 5HC B

I B @GGC H:9FK 69 GD97 ÷ 98.  
 8A 9BG 6BG5F9 B-B7 <9G  
 HC @F5B7 9G  
 : F57 HC B5 @±  
 5B: I @5F: A 57 <± 69B8 ±  
 HK C D@5 7 9897 A 5@±  
 H: F99D@5 7 9897 A 5@±  
 B H9FDF 9H: 9CA 9F7  
 HC @F5B7 B: D9F:  
 A 5H9F 5@  
 : B 6<  
 8C B CHG75 @8F5K B:

	B5A 9	85H9
8F5K B		
7 <97 ?98		
9B: 5DDF"		
A: : 5DDF"		
E "5"		
7 C A A 9BHG		

5 @ A B I A '\$\$\*' ) "  
 H#@.  
 5G<!6!( ' m!%&K !5!H6F!K :!' \$?  
 G#9 8K ; "'BC" F9J  
 5  
 G7 5 @. %\* K 9 ÷ <H' G<99H- 'C: %&

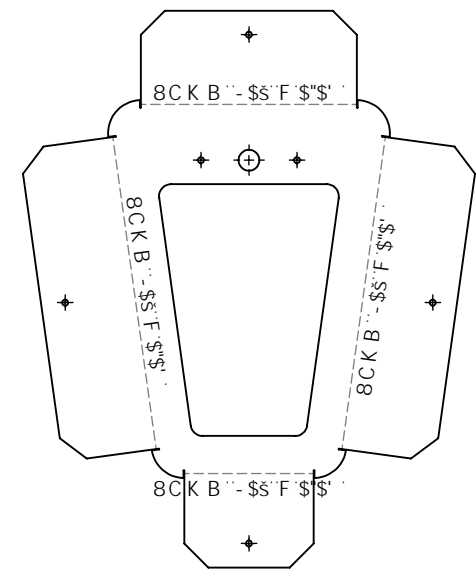
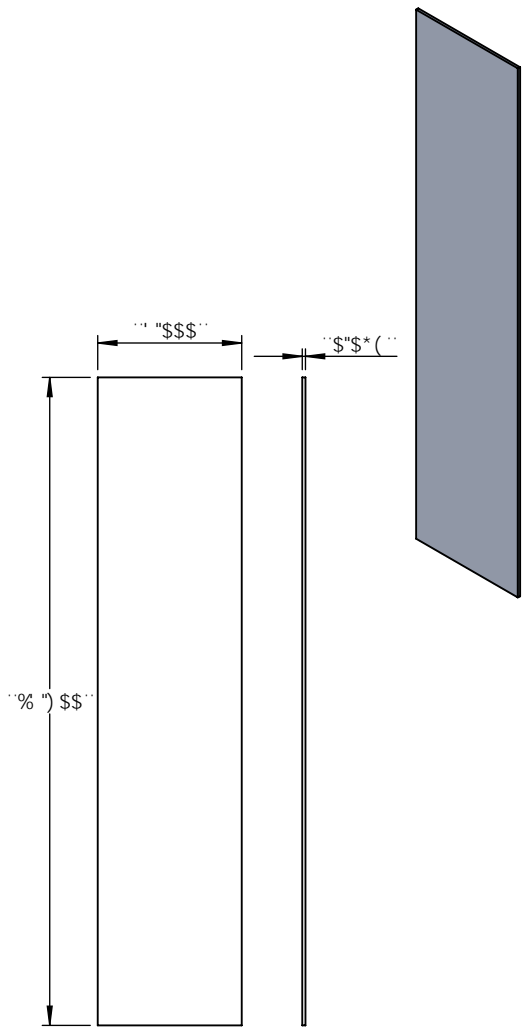
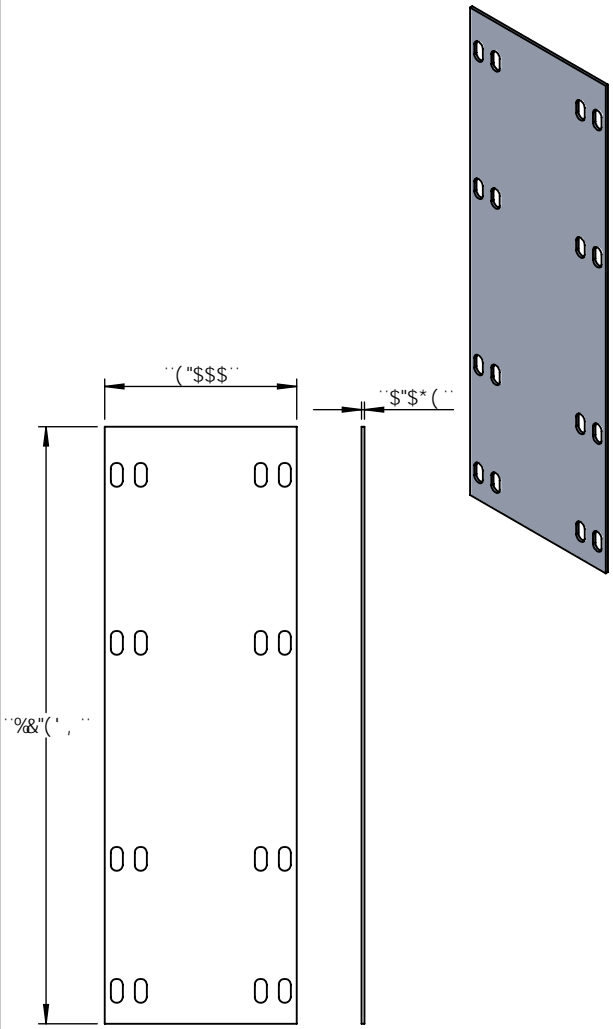

DFC DF 5 FM 5 B 8 7 C B : 8 9 B H 5 @  
 H: 9 B: CFA 5HC B 7 C B H 5 B 98 B H: 6  
 8F5K B: 6H: 9GC @DFC D9F HVC:  
 OBG9FH7CA D5BMB5A 9<9F92" 5BM  
 F9DFC 81 7 HC B -B D5FHCF 5G5 K <C @  
 K H: C I H: 9K F H 9B D9FA 6GC B C:  
 OBG9FH7CA D5BMB5A 9<9F92 6  
 DFC < 6 H 98 \*

		I B @GGCH: 9FK 69 GD97 ÷ 98.	B5A 9	85H9
		8 A 9BG C BG5F9 B B7 <9G HC @F 5B7 9G : F57 HC B5 @± 5B: I @F: A 57 <± ..... 69B 8 ± HC C D @5 7 9 8 97 A 5 @± H: F99 D @5 7 9 8 97 A 5 @±	8F5K B	7 <97 ?98
		B H F D F 9H: 9C A 9F 7 HC @F 5B7 B: D9F.	9B: 5DDF"	A: 5DDF"
		A 5H F 5 @	E "5"	7 C A A 9BHG
B9LH5GGM	I G98 C B	: B 6<		
	5DD @7 5HC B	8C B CHG 7 5 @ 8F5K B:		

5 @ A B I A '\$\$\*' ) "

5G < 16 ( ' m 9 % K ! 5 ! H 6 F ! K : ! ' \$ ?

G A 9	8 K ; " " BC "	F 9 J
<b>5</b>		
G 7 5 @ . % (	K 9 ÷ < H '	G < 99 H % \$ C : % &

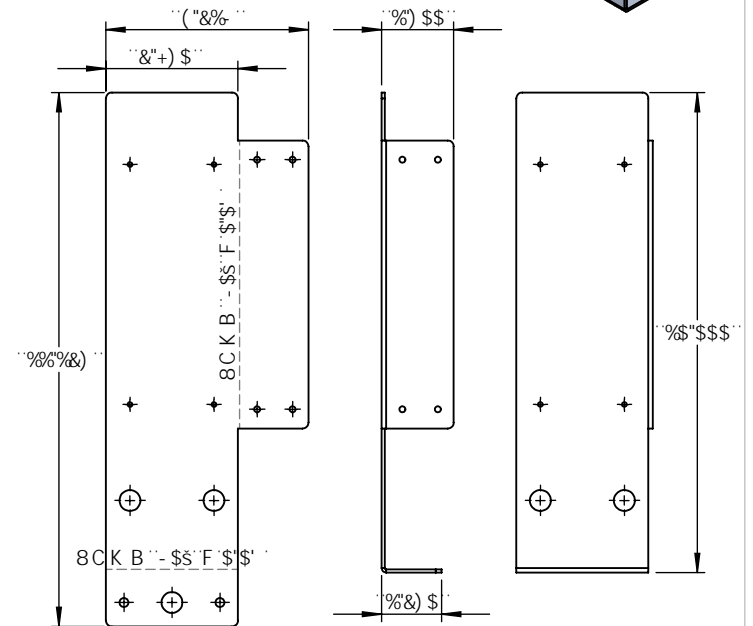
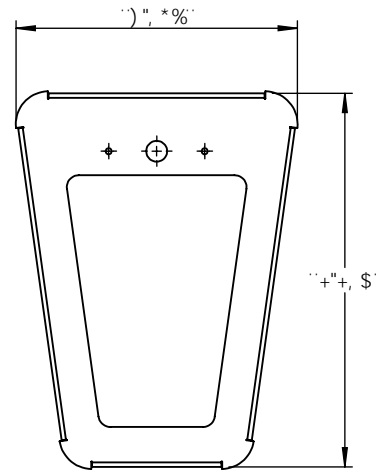
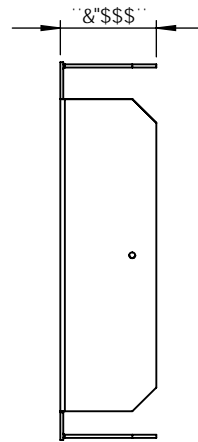
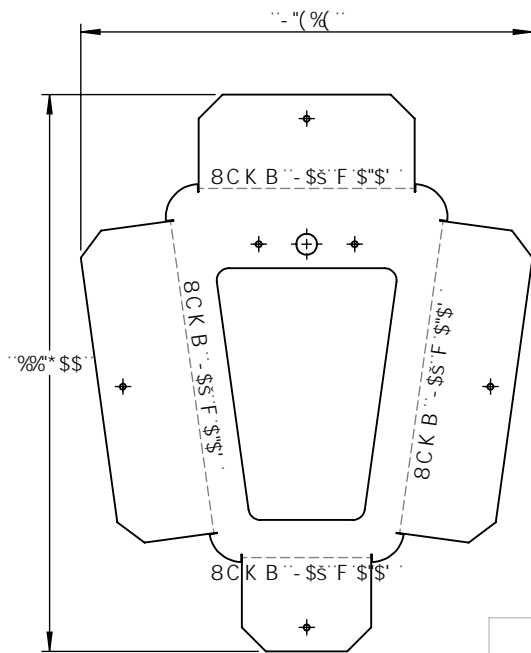
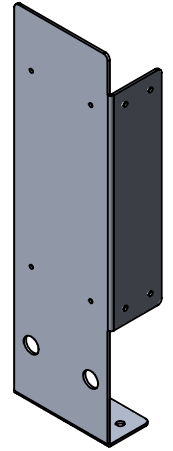
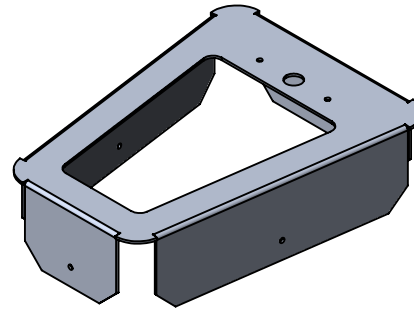
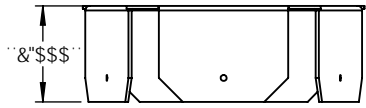

DFC DF 5 FM 5 B 8 7 CB: 8 9 B H 5 @  
 H: 9 B: CFA 5 HC B 7 C B H 5 B 9 8 B H: 6  
 8 F 5 K B: 6 H: 9 GC @ DFC D 9 F H M C:  
 O B G 9 F H 7 C A D 5 B M B 5 A 9 < 9 F 9 2 " 5 B M  
 F 9 D F C 8 1 7 H C B B D 5 F H C F 5 G 5 K < C @  
 K H: C 1 H H: 9 K F H 9 B D 9 F A 6 G B C:  
 O B G 9 F H 7 C A D 5 B M B 5 A 9 < 9 F 9 2 G  
 D F C < 6 H 9 8 "

		I B @ G G C H: 9 F K 6 9 G D 9 7 ÷ 9 8.		B 5 A 9	8 5 H 9
		8 A 9 B G C B G 5 F 9 B B 7 < 9 G H C @ F 5 B 7 9 G : F 5 7 H C B 5 @ ± 5 B: I @ F: A 5 7 < ± ..... 6 9 B 8 ± H K C D @ 5 7 9 8 9 7 A 5 @ ± H: F 9 9 D @ 5 7 9 8 9 7 A 5 @ ±	8 F 5 K B 7 < 9 7 9 8 9 B: 5 D D F" A: 5 D D F"		
		B H F D F 9 H: 9 C A 9 F 7 H C @ F 5 B 7 B: D 9 F. A 5 H F 5 @	E " 5" 7 C A A 9 B H G		
B 9 L H 5 G G M	I G 9 8 C B	: B G <			
	5 D D @ 7 5 H C B	8 C B C H G 7 5 @ 8 F 5 K B:			

5 @ A B I A "\$ \$ \* ' ) "

H @.

5 G < ! 6 ! ( ' m i % & K ! 5 ! H 6 F ! K : ! ' \$ ?

G A 9 8 K ; " " B C " F 9 J

5

G 7 5 @ . % ( K 9 ÷ < H ' G < 9 9 H % % C : % &

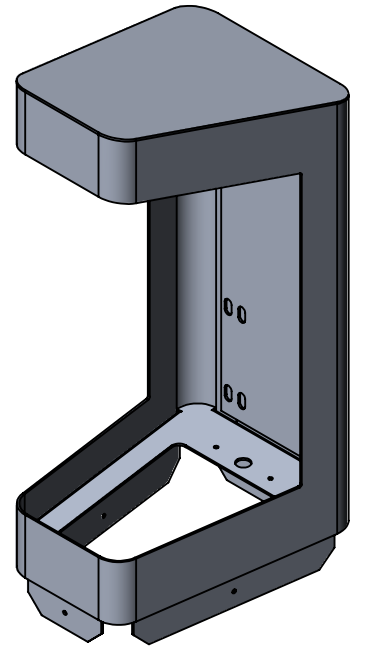
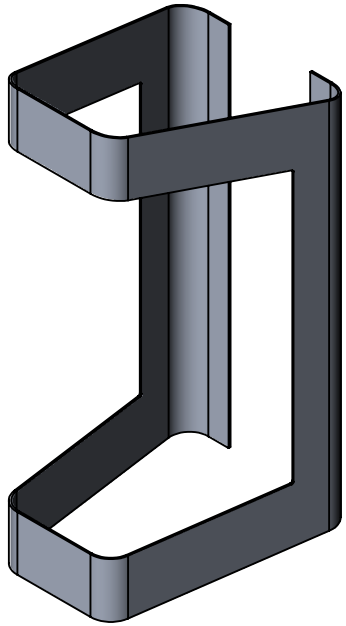
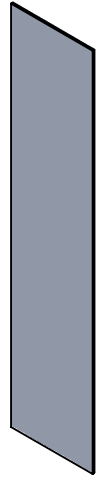
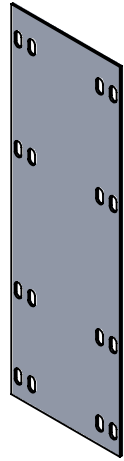
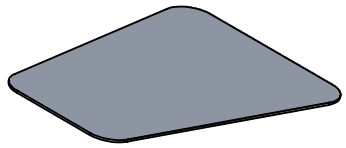

5@K 9@98 5GCB9D-97 9

