

#DA BC "	D5FHBI A 69F	8 9G7 F-DHC B	E HM 7 I H
%	9J C @&\$!K !&&!%&K !A 6?!K 85!' \$?!\$"& \$\$\$\$-? ? D@H9	%#(""-B7 < '5@ A -B I A 'D@H9	%
&	9J C @&\$!K !&&!%&K !A 6?!K 85!' \$?: F5A 9GD57 9F	5@ A -B I A '\$"\$*') "	%
'	9J C @&\$!K !&&!%&K !A 6?!K 85!' \$?!@8 GD57 9F	5@ A -B I A '\$"\$*') "	%
(9J C @&\$!K !&&!%&K !A 6?!K 85!' \$?!657 ?D@H9	5@ A -B I A '\$"\$*') "	%
)	9J C @&\$!K !&&!%&K !A 6?!K 85!' \$?: F9D@H9	5@ A -B I A '\$"\$*') "	%
*	9J C @&\$!K !&&!%&K !A 6?!K 85!' \$?: -B G8 9: @B: 9	&) ; 5 I ; 9	(
+	9J C @!K !&&FC I B8 : CFA 98 @BG	57 FM@7	%
,	9gdYbH7 <S%&\$&+J SG? I , \$, \$+*	8F @ 9F	%
-	5 HU @8 SDB %&\$\$(FYj 8	@8	&

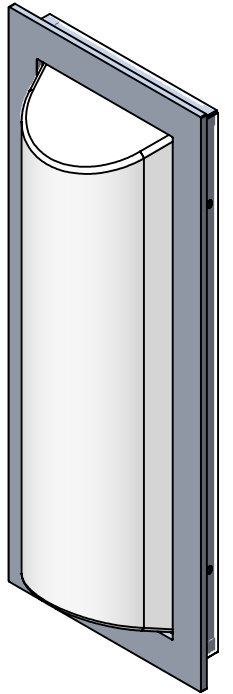

EVERGREEN LIGHTING

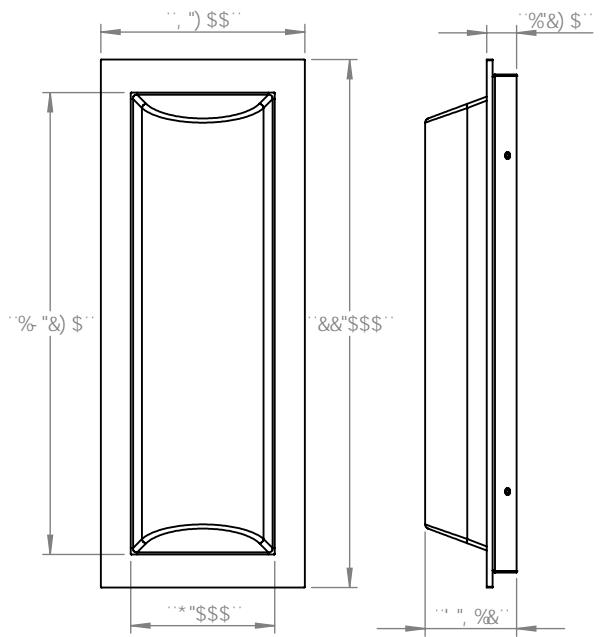
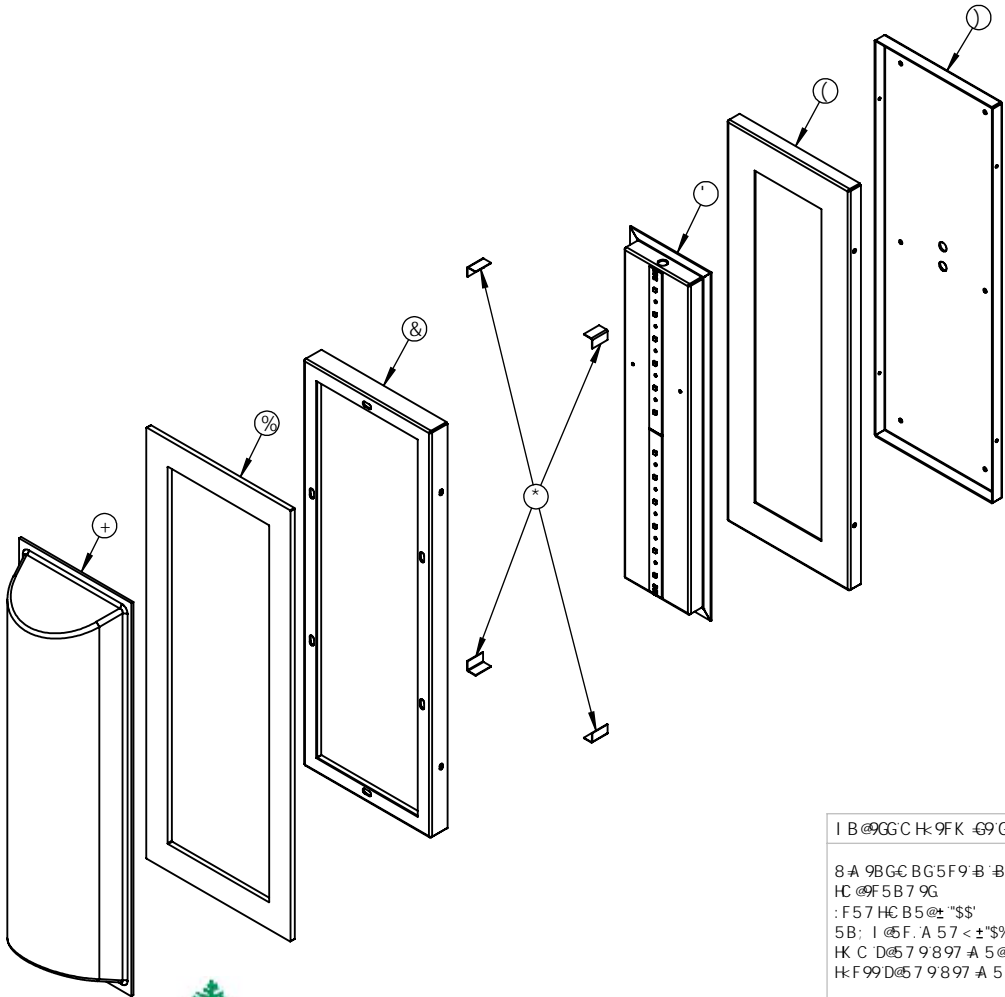

I B @GGC H: 9FK @9 GD97 ÷ 98.	B5A 9	85H9	H#@.
8-A 9BG@ BG5F9-B -B7 < 9G HC @F5B7 9G : F57 HC B5 @± "\$\$' 5B: I @F: A 57 < ± "\$%''69B8 ± K C D@57 9897-A 5@ ± "\$\$% H: F99D@57 9897-A 5@ ± "\$\$%	8F5K B		
-B H@FDF 9H: 9C A 9FF 7 HC @F5B7 B: D9F. A 5H@F 5@	9B: 5DDF"		G#9 8K ; ""BC" 5 H7 ? 9H&' (* - F9J
: B @<	A : : 5DDF"	7 C A A 9BHG	
5 @@69B8 F58 ± G "\$ \$ "			G < 99H % C : -
5DD@7 5HC B	8C BC HG7 5 @ 8F5K B:		

) (' & %

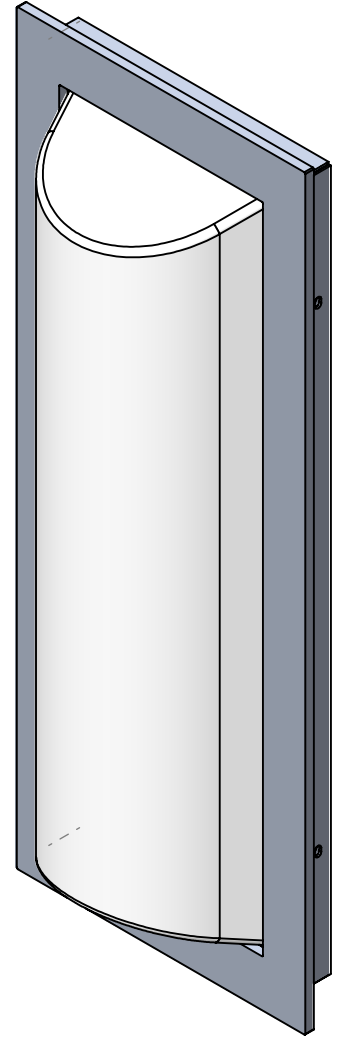
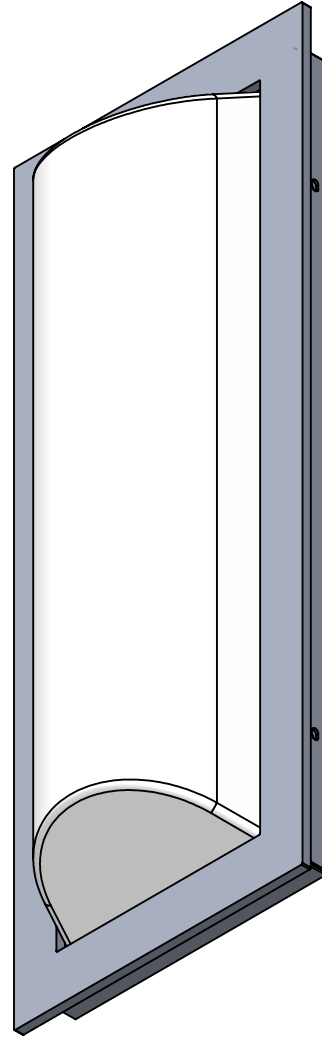
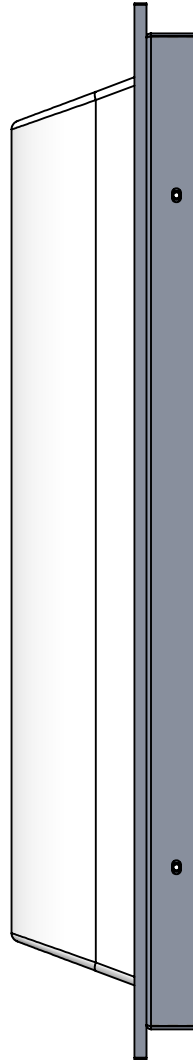
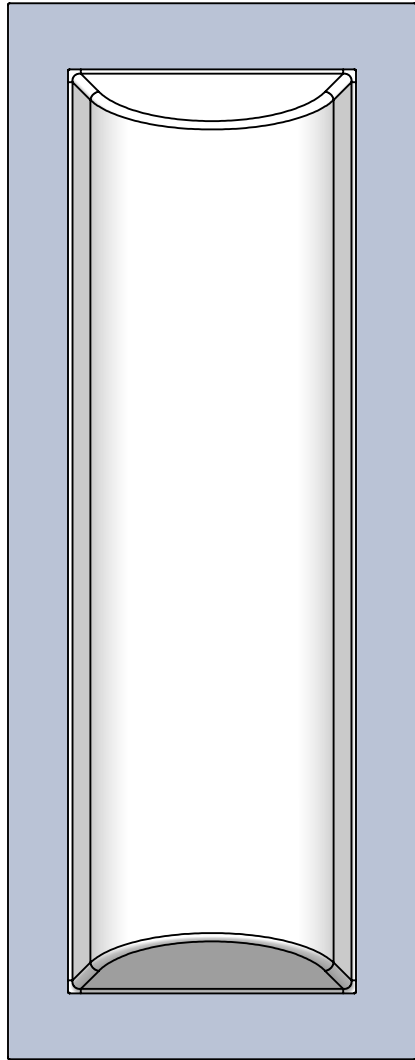
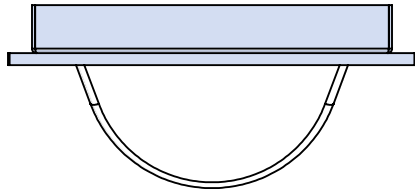

:F5A 95B8'D5H7K 9@98:CF'
58898'GF9B; Hk'

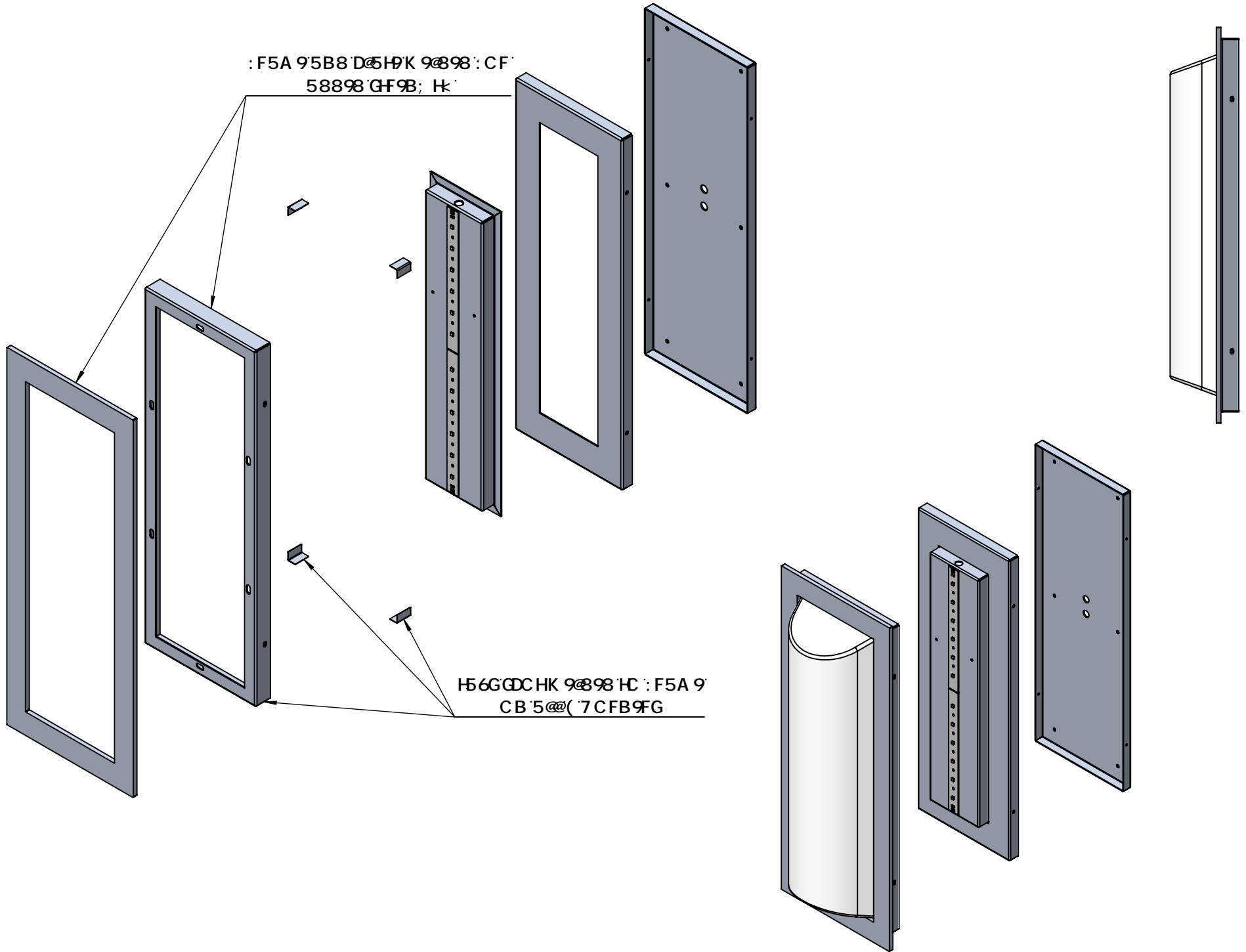

H56GDC HK 9@98'HC : F5A 9
CB'5@('7CFB9FG

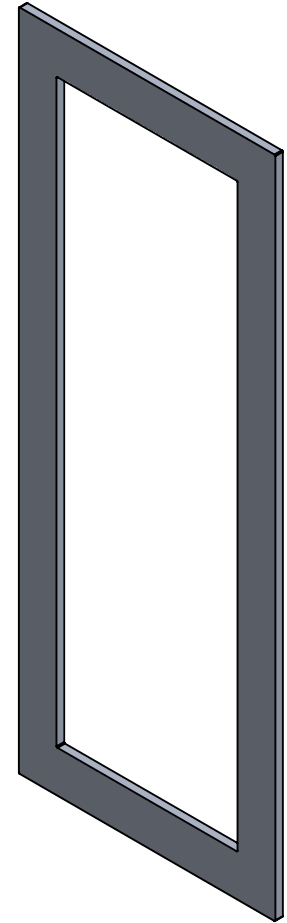
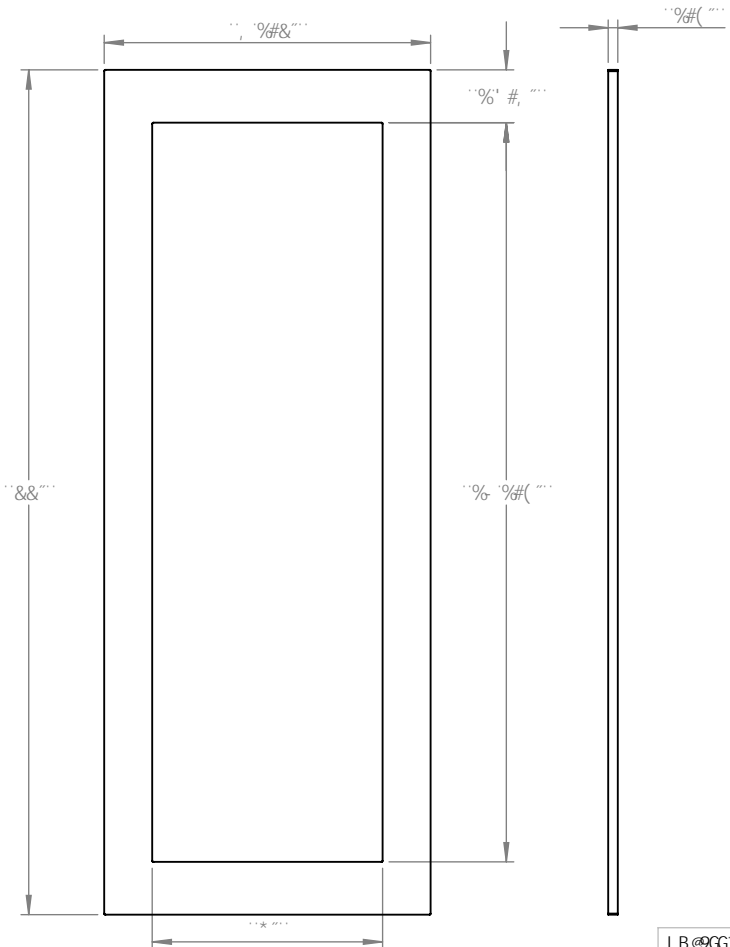

DFC DF-96FM5B87CB: 89BH5@
 H:9-B: CFA 5HC B 7 C BH5 B98 B H-6
 8F5K B; 6H-9GC @DFC D9FHMC:
 OB 9FH7 CA D5BMB5A 9<9F92" 5BM
 F9DFC 81 7 HC B -B D5FHC F 5G5 K <C @
 K H-C I H:9K F H9B D9FA 6GC B C:
 OB 9FH7 CA D5BMB5A 9<9F92 6
 DFC <6H98"

B9LH5GGM	I G98 C B
5DD@7 5HC B	

I B @GGC H: 9FK 69 GD97 ÷ 98.
 8 A 9BG C BG5F9 B B7 <9G
 HC @F 5B7 9G
 : F57 HC B5 @±
 5B; I @5F: A 57 <±69B8 ±
 HK C D@57 9897 A 5@''±
 H: F99D@57 9897 A 5@±

BH9DF9H: 9C A 9F 7
 HC @F 5B7 B; D9F.
 A 5H9F 5@
 : B 6<

	B5A 9	85H9
8F5K B		
7 <97 ?98		
9B; 5DDF"		
A:; 5DDF"		
E "5"		
7 C A A 9BHG		

%#("" B7 <'5@ A B I A 'D@H9		
H#@.		
9J C @&\$!K !&&!%&K !A 6?!K 85!' \$?		
G#9	8K; ""BC"	F9J
5		
G7 5 @.%)	K 9 ÷ <H'	G<99H('C: '-

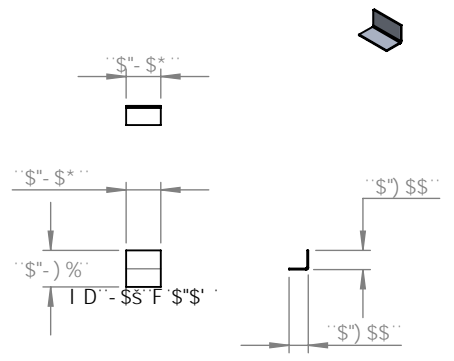
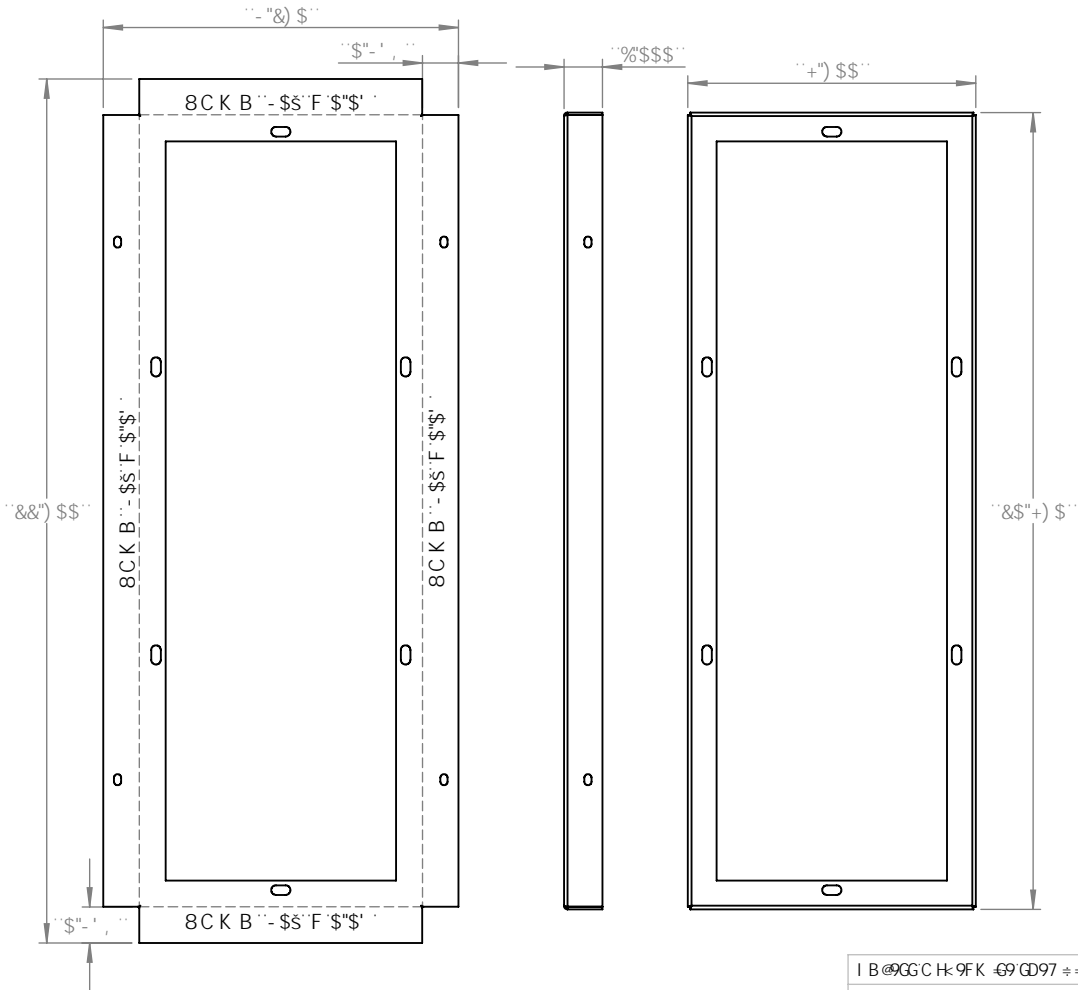

DFC DF-96FM5B87CB: 89BH5@
 H:9 B: CFA 5HC B 7 C BH5 B98 B H:6
 8F5K B: 6H:9GC @DFC D9F HMC:
 OB 9FH7 CA D5BMB5A 9 < 9F 92" 5BM
 F9DFC 81 7 HC B -B D5FHC F 5G5 K < C @
 K H: C I H: 9K F H9B D9FA 6GB C:
 OB 9FH7 CA D5BMB5A 9 < 9F 92 6
 DFC < 6H98"

B9LH5GGM	I G98 C B
5DD@7 5HC B	

I B @GGC H: 9FK 69 GD97 ÷ 98.
8 A 9BG C BG5F9 B -B7 < 9G HC @F 5B7 9G ; F57 HC B5 @± 5B; I @5F: A 57 < ± 69B 8 ± HK C D @5 7 9 8 97 A 5 @ ± H: F99 D @5 7 9 8 97 A 5 @ ±
B H9F DF 9H: 9C A 9F 7 HC @F 5B7 B: D9F. A 5H9F 5 @
: B 6<
8C B CHG7 5 @9 8F5K B:

	B5A 9	85H9
8F5K B		
7 < 97 ? 98		
9B: 5DDF"		
A: : 5DDF"		
E "5"		
7 C A A 9BHG		

5 @ A B I A '\$\$*') "		
H#@.		
9J C @ \$!K ! &&! % &K ! A 6?!K 85!' \$?		
G#9	8K ; ""BC"	F9J
5		
G7 5 @. %)	K 9 ÷ < H'	G< 99H) 'C: '-

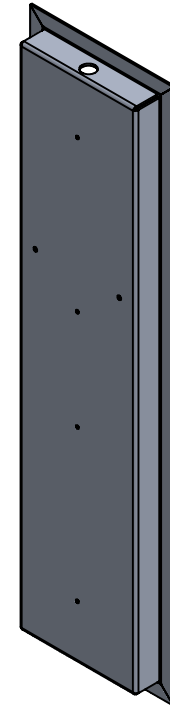
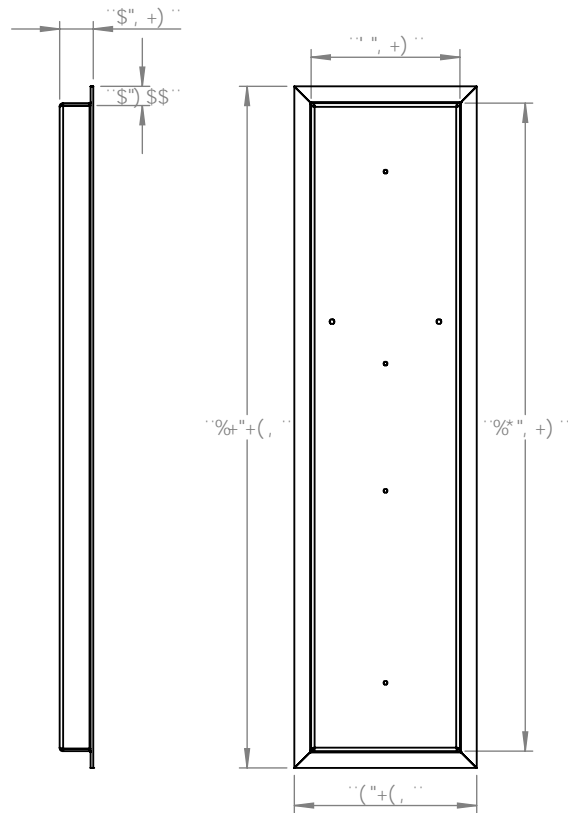
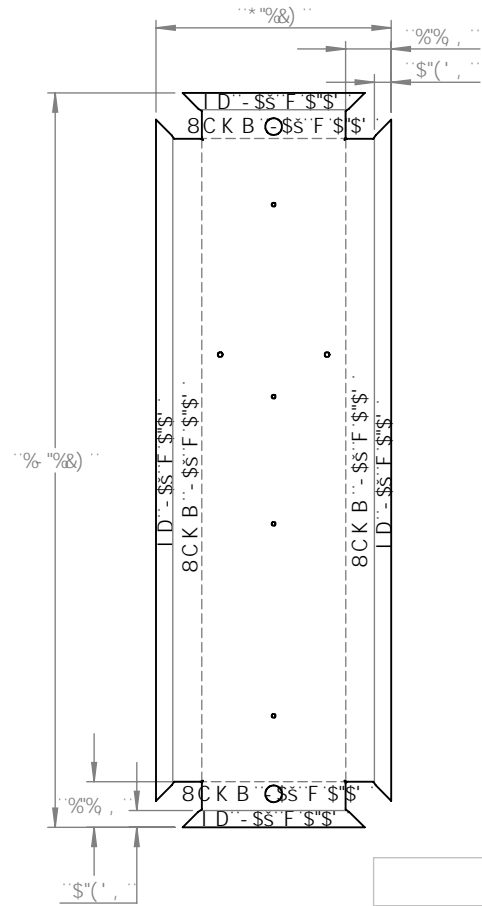

DFC DF-96FM5B87CB: 89BH5@
 H-9-B: CFA 5HC B 7 C BH5 B98 B H-6
 8F5K B: 6H-9GC @DFC D9F HMC:
 OB 9FH7 CA D5BMB5A 9 < 9F 92" 5BM
 F9DFC 81 7 HC B -B D5FHCF 5G5 K < C @
 K H-C I H-9K F H9B D9FA GGB C:
 OB 9FH7 CA D5BMB5A 9 < 9F 92 G
 DFC < 6H98"

		I B @GGCH: 9FK @9 GD97 ≠ 98.	B5A 9	85H9	5 @ A B I A '\$\$*') "
		8 A 9BG C BG5F9 B B7 < 9G HC @F 5B7 9G : F57 HC B5 @± 5B: I @F: A 57 < ± 69B8 ± HK C D @5 7 9 8 97 A 5 @ ± H: F99 D @5 7 9 8 97 A 5 @ ±	8F5K B		H#@.
		B H9F DF 9H: 9C A 9F 7 HC @F 5B7 B: D9F.	7 < 97 ? 98		9J C @ \$! K ! & & ! % & K ! A 6 ? ! K 8 5 ! '\$?
		A 5 H9F 5 @	9B: 5 DDF"		
		: B @ <	A: : 5 DDF"		
B9LH5GGM	I G98 C B		E "5"		
		8C B CHG7 5 @ 8F5K B:	7 C A A 9BHG		
	5DD @ 7 5HC B				G A 9 8K ; "'BC" F9J
					G7 5 @. %) K 9 ≠ < H' G < 99H* 'C : '-

)

(

&

%

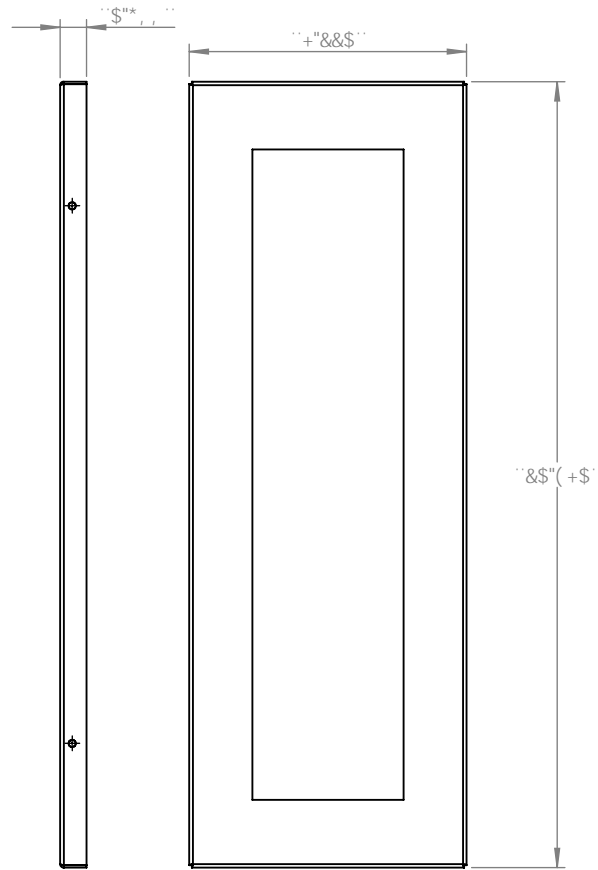
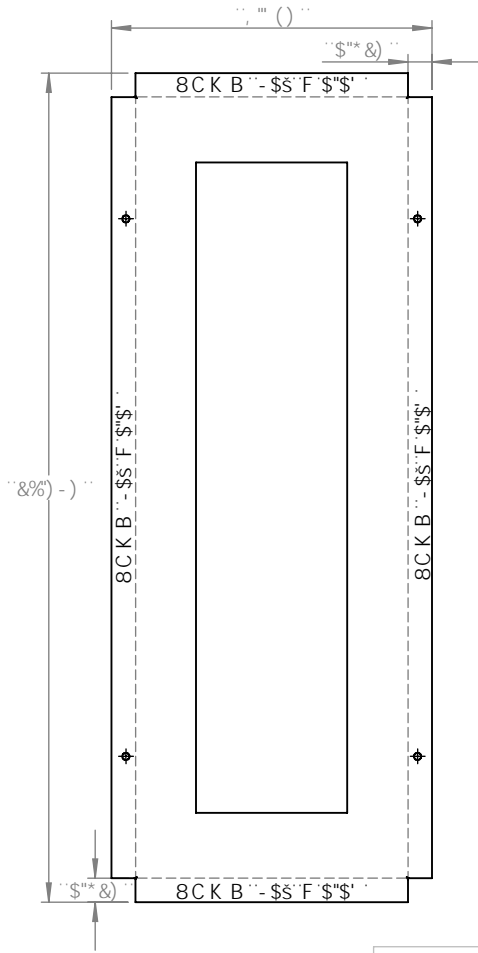

DFC DF-96FM5B87CB: 89BH5@
 H:9 B: CFA 5HC B 7 C BH5 B98 B H:G
 8F5K B: 6H:9GC @DFC D9FHMC:
 OB9FH7 CA D5BMB5A 9<9F92" 5BM
 F9DFC 81 7 HC B -B D5FHCF 5G5 K <C @
 K H:C I H:9K F H98 D9FA GGB C:
 OB9FH7 CA D5BMB5A 9<9F92 G
 DFC <6H98"

		I B @GGCH:9FK 69GD97 ÷ 98.	B5A 9	85H9	5 @ A B I A '\$\$*') "
		8 A 9BG C BG5F9 B B7 <9G HC @F5B7 9G :F57 HC B5 @± 5B: I @F: A 57 <±69B8 ± HK C D@579897 A 5@± H:F99D@579897 A 5@±	8F5K B		H#@.
		B H9FDF9H: 9C A 9F 7 HC @F5B7 B: D9F.	7 <97 ?98		9J C @\$!K !&&!%&K !A 6?!K 85!' \$?
		A 5H9F 5@	9B: 5DDF"		
		: B G<	A: : 5DDF"		
B9LH5GGM	I G98 C B		E "5"		
		8C BCHG75 @98F5K B:	7 C A A 9BHG		
	5DD@7 5HC B				G#9 8K ; "'BC" F9J
					G7 5 @.%) K 9 ÷ <H' G<99H+C: '-

)

(

&

%

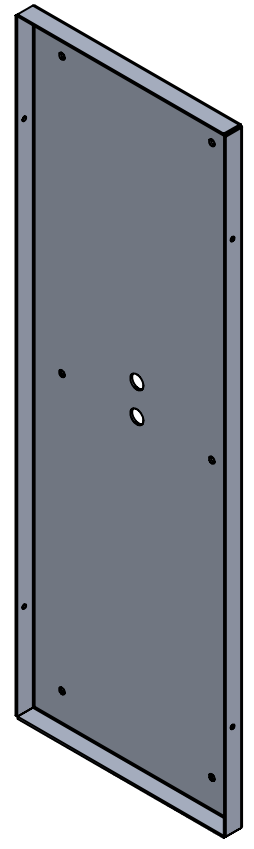
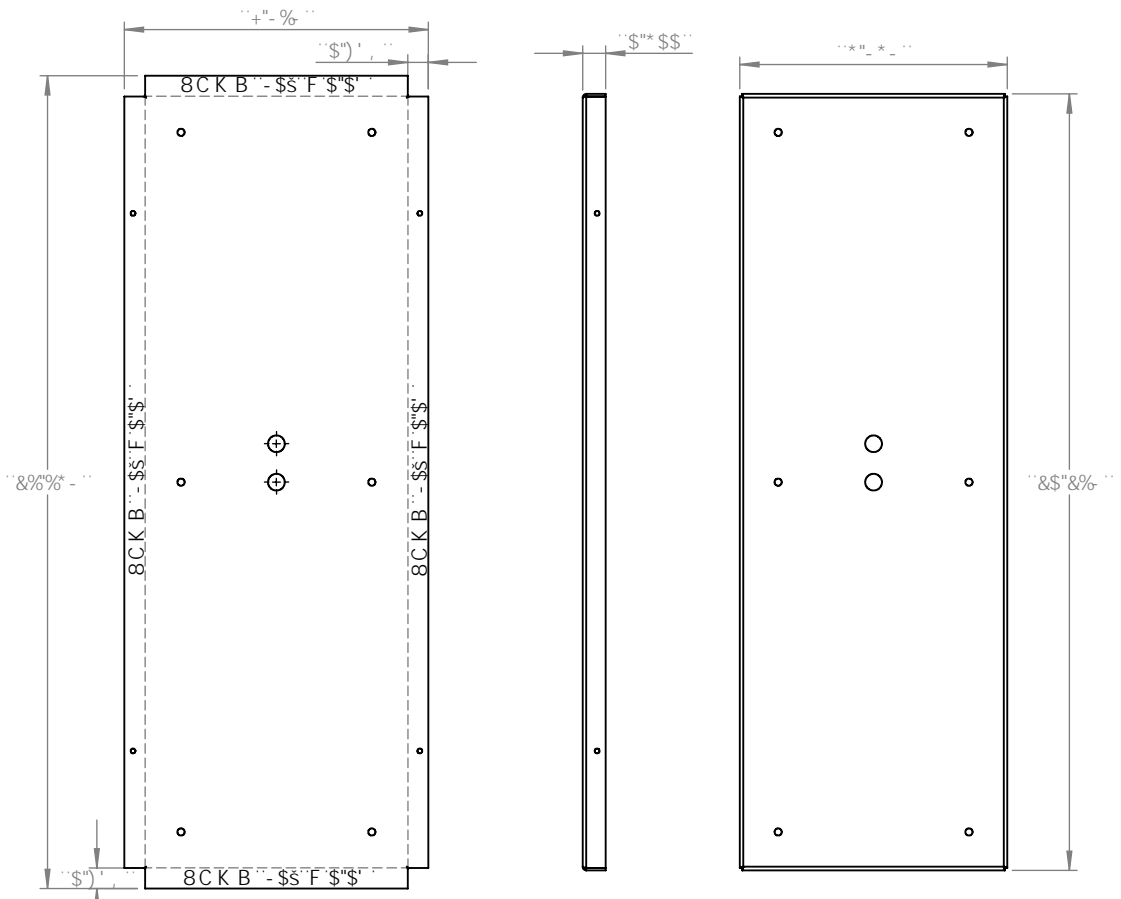

DFC DF-96FM5B87CB: 89BH5@
 H-9-B: CFA 5HC B 7 C B H5 B 98 B H-6
 8F5K B: 6H-9GC @DFC D9FHMC:
 OB 9FH7 CA D5BMB5A 9<9F92" 5BM
 F9DFC 81 7 HC B -B D5FHCF 5G5 K <C @
 K H-C1 H H-9K F H 98 D9FA 6GC B C:
 OB 9FH7 CA D5BMB5A 9<9F92 6
 DFC <6H98"

		I B @GGCH: 9FK 69 GD97 ÷ 98.	B5A 9	85H9	5 @ A B I A '\$\$*')"
		8 A 9BG C BG5F9 B B7 <9G HC @F5B7 9G ; F57 HC B5 @± 5B: I @F: A 57 <± 69B8 ± HK C D @57 9897 A 5 @± H: F99D @57 9897 A 5 @±	8F5K B		H#@.
		B H9FDF9H: 9C A 9F 7 HC @F5B7 B: D9F.	7 <97 ?98		9J C @&\$!K !&&!%&K !A 6?!K 85!' \$?
		A 5H9F 5@	9B: 5DDF"		
		: B 6<	A: : 5DDF"		
B9LH5GGM	I G98 C B		E "5"		
		8C B CHG75 @98F5K B:	7 C A A 9BHG		
5DD@7 5HC B					G#9 8K ; "'BC" F9J
					5
					G7 5 @.%) K 9 ÷ <H' G<99H, 'C: '-

