

ALL BEND RADIUS .030"

UNLESS OTHERWISE SPECIFIED:
 DIMENSIONS ARE IN INCHES
 TOLERANCES:
 FRACTIONAL ± .003
 ANGULAR: MACH ± .01 BEND ±
 TWO PLACE DECIMAL ±
 THREE PLACE DECIMAL ±.001

INTERPRET GEOMETRIC
 TOLERANCING PER:
 MATERIAL
 FINISH

NAME	DATE
DRAWN	
CHECKED	
ENG APPR.	
MFG APPR.	
Q.A.	
COMMENTS:	

TITLE:
 GOTH-2-P31-200W-ORB-WF-DIM-30K

SIZE	DWG. NO.	REV
A	TICKET 24531	
SCALE: 1:14	WEIGHT:	SHEET 1 OF 10

5

4

3

2

1

APPLICATION

DO NOT SCALE DRAWING

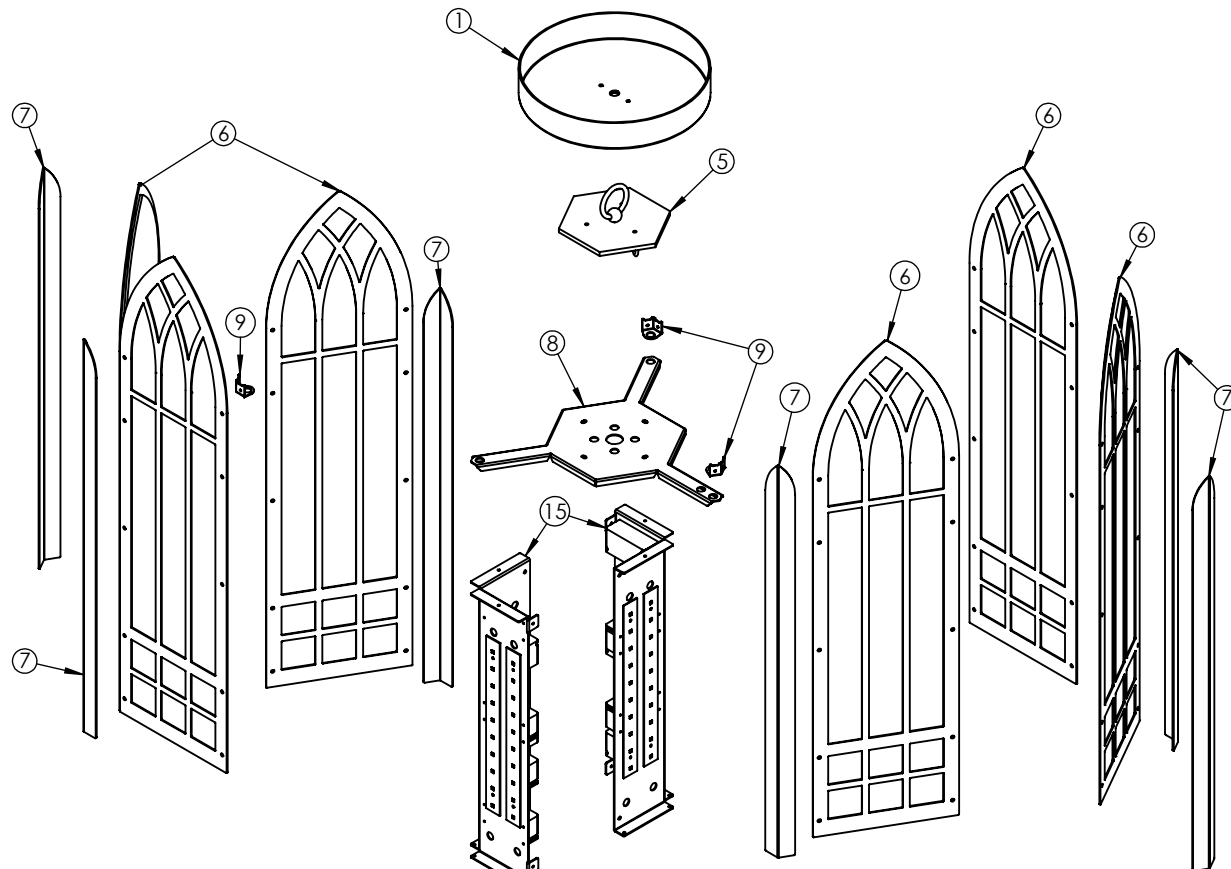

ITEM NO.	PART NUMBER	DESCRIPTION	QTY.	CUT
1	10" SWIVEL CANOPY	SPUN ALUMINUM 0.080"	1	
2	CHAIN BRACKET	BRASS	2	
3	.375 BRASS BALL	BRASS BALL	2	
4	BRASS RING	BRASS	6	
5	GOTH-2-P31-200W-ORB-WF-DIM-30K-HEXAGON CHAIN PLATE	ALUMINUM 0.250" PLATE	1	
6	GOTH-2-P31-200W-ORB-WF-DIM-30K-SIDE	ALUMINUM 0.0635"	6	
7	GOTH-2-P31-200W-ORB-WF-DIM-30K-VERTICAL TAB	ALUMINUM 0.0635"	6	
8	GOTH-2-P31-200W-ORB-WF-DIM-30K-HEXAGON TOP	ALUMINUM 0.0635"	1	
9	GOTH-2-P31-200W-ORB-WF-DIM-30K-SUPPORT BRACKET	ALUMINUM 0.0635"	3	
10	GOTH-2-P31-200W-ORB-WF-DIM-30K-HEXAGON BOTTOM	ALUMINUM 0.0635"	1	
11	GOTH-2-P31-200W-ORB-WF-DIM-30K-HEXAGON LED PLATE	ALUMINUM 0.0635"	1	
12	GOTH-2-P31-200W-ORB-WF-DIM-30K-HEXAGON BOTTOM DOOR	ALUMINUM 0.0635"	1	
13	GOTH-2-P31-200W-ORB-WF-DIM-30K-ACRYLIC	ACRYLIC	6	
14	GOTH-2-P31-200W-ORB-WF-DIM-30K-HEXAGON ACRYLIC	ACRYLIC	1	
15	GOTH-2-P31-200W-ORB-WF-DIM-30K-LED PLATE	ALUMINUM 0.0635"	2	
16	Altaj LED PN1019 SHIM PLATE	ALUMINUM 0.125" PLATE	12	
17	AltajLED PN110B RevC	LED	8	
18	Altaj LED PN1019 RevC	LED	12	
19	AC25CD700AT2Q LED DRIVER	DRIVER	10	

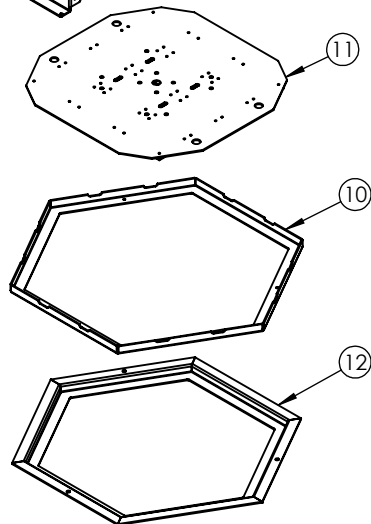

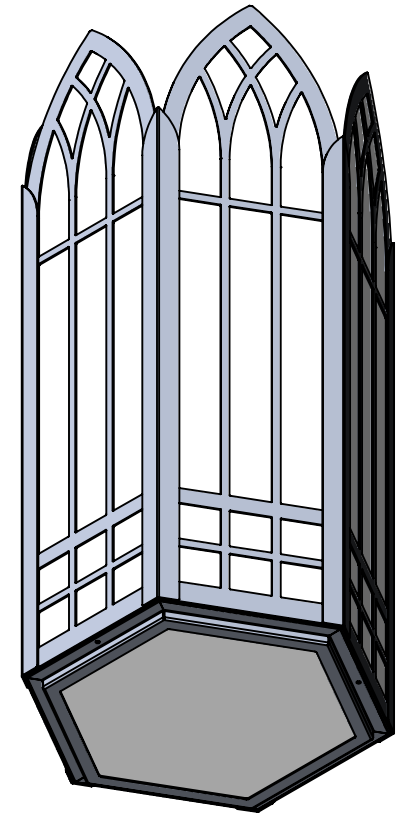
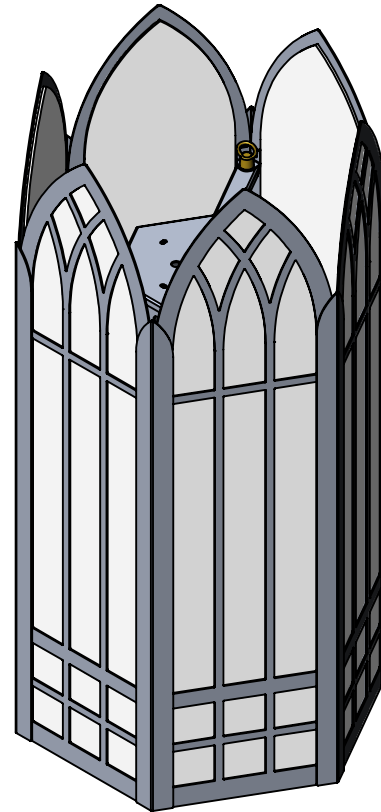
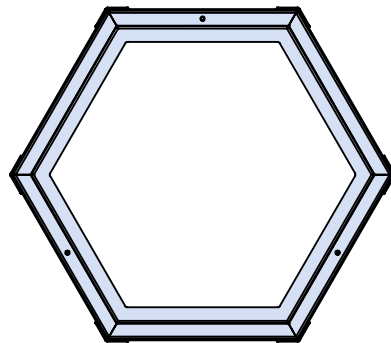
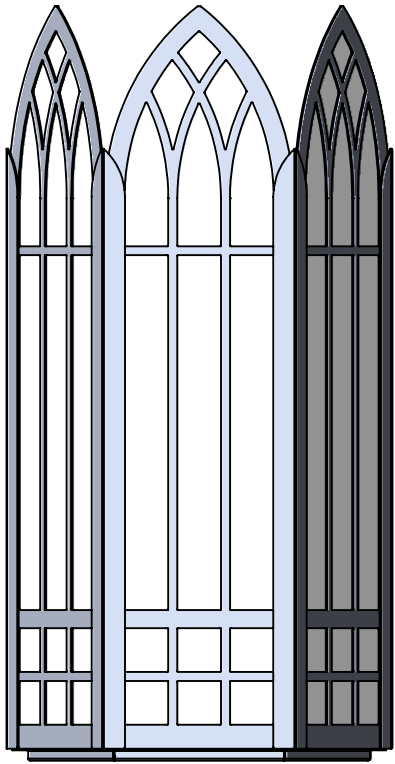
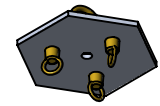
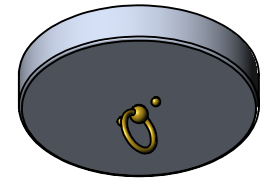
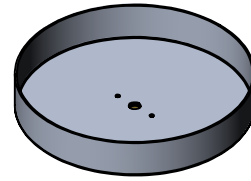
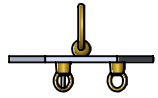
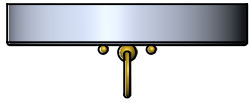

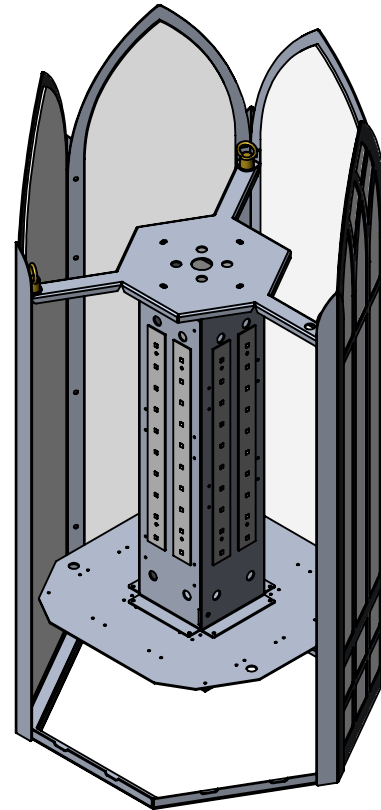
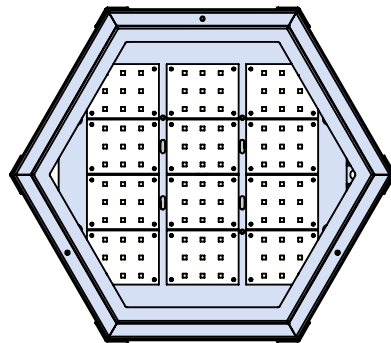
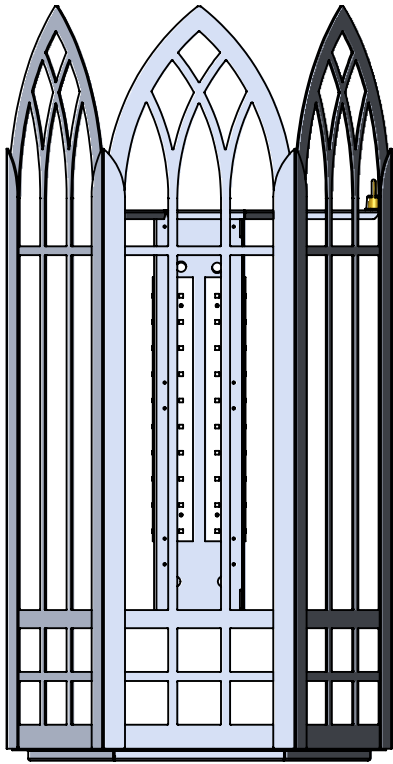
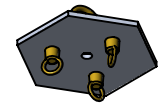
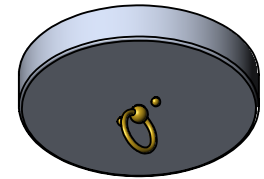
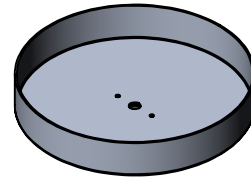
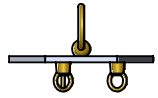
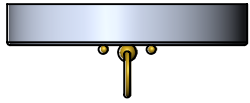

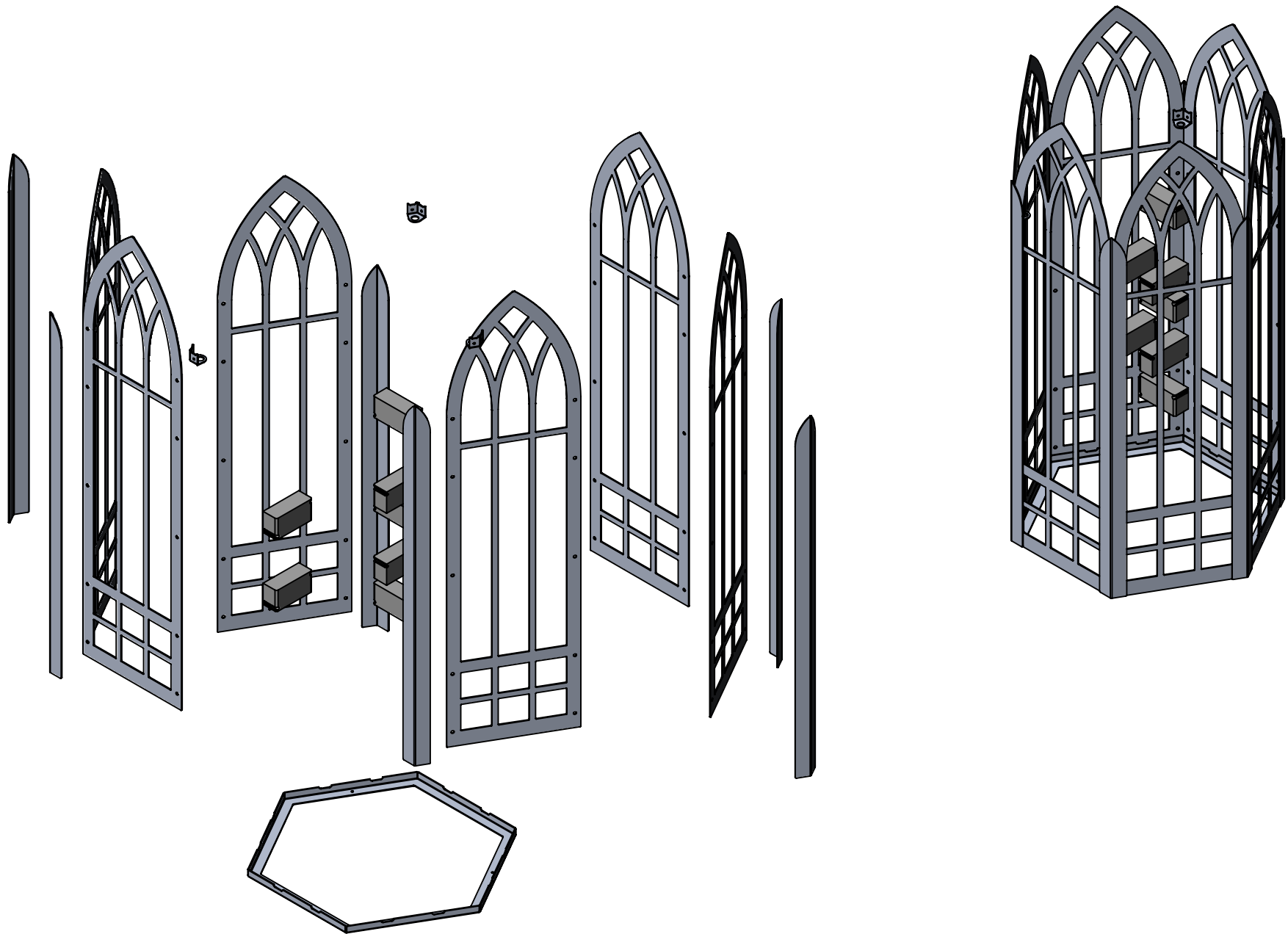

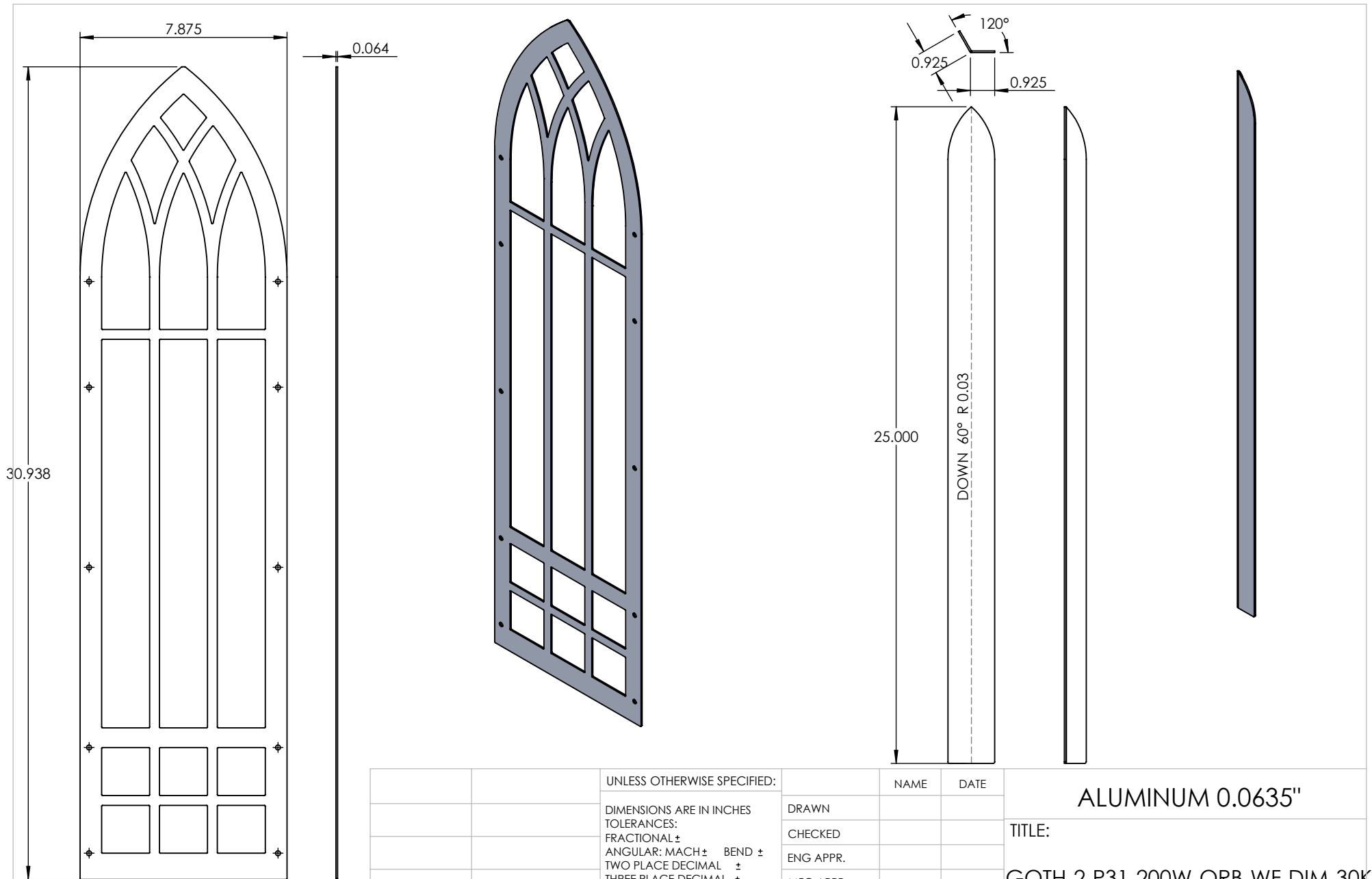

PROPRIETARY AND CONFIDENTIAL
 THE INFORMATION CONTAINED IN THIS DRAWING IS THE SOLE PROPERTY OF <INSERT COMPANY NAME HERE>. ANY REPRODUCTION IN PART OR AS A WHOLE WITHOUT THE WRITTEN PERMISSION OF <INSERT COMPANY NAME HERE> IS PROHIBITED.

		UNLESS OTHERWISE SPECIFIED:	NAME	DATE
		DIMENSIONS ARE IN INCHES	DRAWN	
		TOLERANCES:	CHECKED	
		FRACTIONAL ±	ENG APPR.	
		ANGULAR: MACH ± BEND ±	MFG APPR.	
		TWO PLACE DECIMAL ±	Q.A.	
		THREE PLACE DECIMAL ±	COMMENTS:	
		INTERPRET GEOMETRIC TOLERANCING PER:		
		MATERIAL		
NEXT ASSY	USED ON	FINISH		
APPLICATION		DO NOT SCALE DRAWING		

ALUMINUM 0.0635"		
TITLE:		
GOTH-2-P31-200W-ORB-WF-DIM-30K		
SIZE	DWG. NO.	REV
A		
SCALE: 1:5	WEIGHT:	SHEET 6 OF 10

5

4

3

2

1

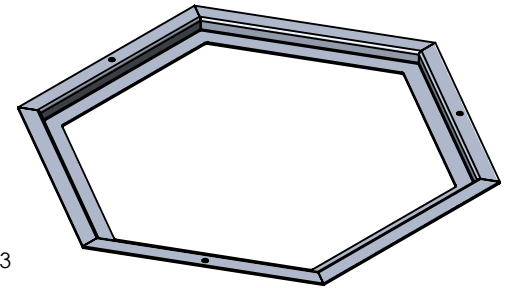
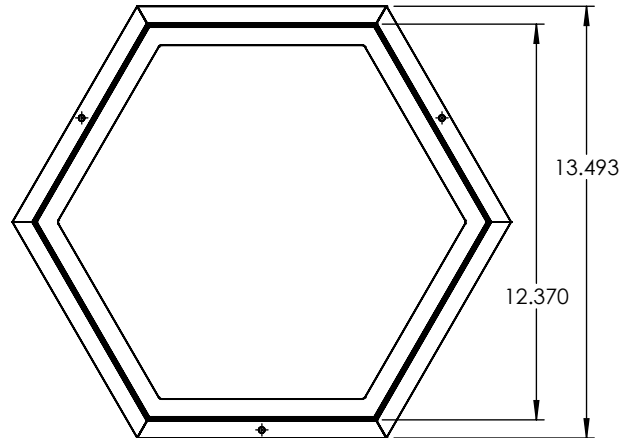
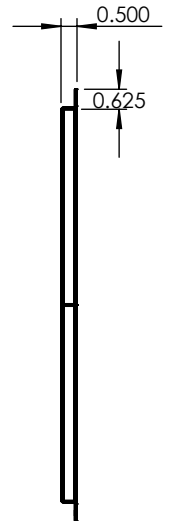
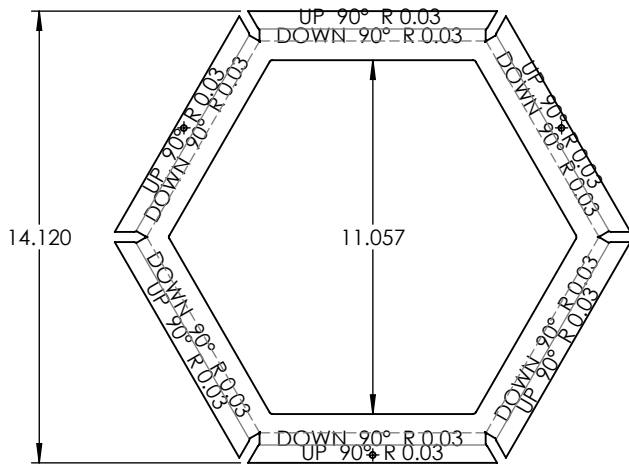
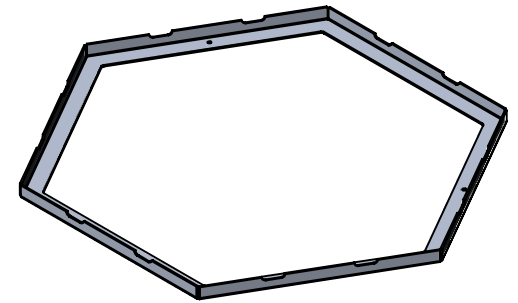
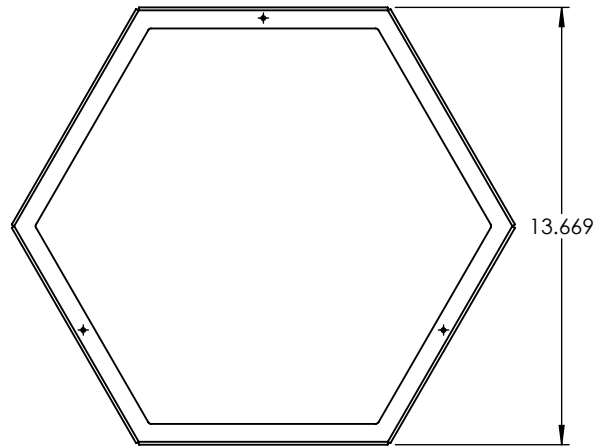
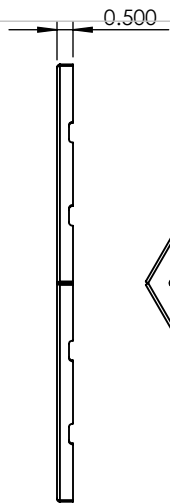
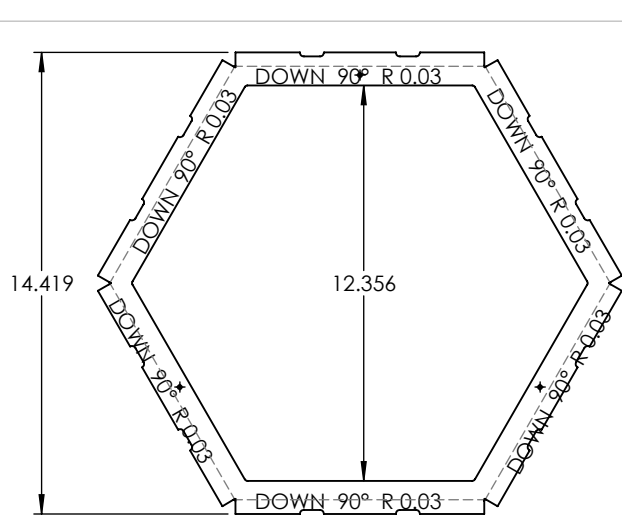

PROPRIETARY AND CONFIDENTIAL
 THE INFORMATION CONTAINED IN THIS DRAWING IS THE SOLE PROPERTY OF <INSERT COMPANY NAME HERE>. ANY REPRODUCTION IN PART OR AS A WHOLE WITHOUT THE WRITTEN PERMISSION OF <INSERT COMPANY NAME HERE> IS PROHIBITED.

		UNLESS OTHERWISE SPECIFIED:		NAME	DATE
		DIMENSIONS ARE IN INCHES	DRAWN		
		TOLERANCES:	CHECKED		
		FRACTIONAL ±	ENG APPR.		
		ANGULAR: MACH ± BEND ±	MFG APPR.		
		TWO PLACE DECIMAL ±	Q.A.		
		THREE PLACE DECIMAL ±	COMMENTS:		
		INTERPRET GEOMETRIC TOLERANCING PER:			
		MATERIAL			
	NEXT ASSY	FINISH			
	USED ON				
	APPLICATION	DO NOT SCALE DRAWING			

ALUMINUM 0.0635"		
TITLE:		
GOTH-2-P31-200W-ORB-WF-DIM-30K		
SIZE	DWG. NO.	REV
A		
SCALE: 1:6	WEIGHT:	SHEET 7 OF 10

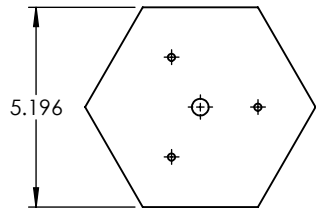
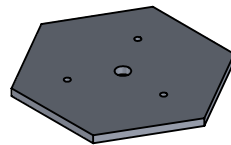
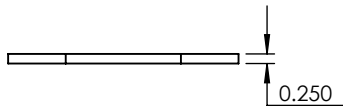
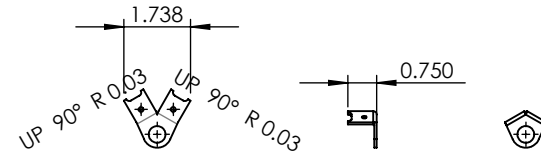
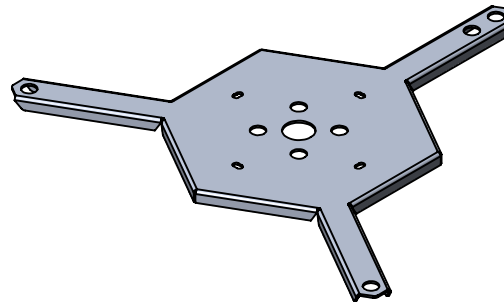
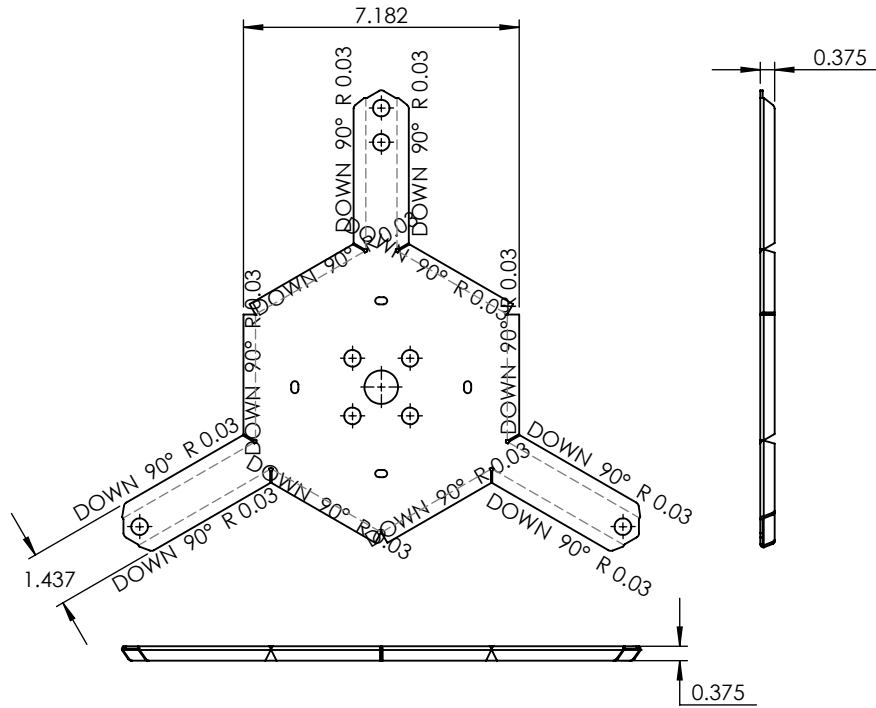

PROPRIETARY AND CONFIDENTIAL
 THE INFORMATION CONTAINED IN THIS DRAWING IS THE SOLE PROPERTY OF <INSERT COMPANY NAME HERE>. ANY REPRODUCTION IN PART OR AS A WHOLE WITHOUT THE WRITTEN PERMISSION OF <INSERT COMPANY NAME HERE> IS PROHIBITED.

		UNLESS OTHERWISE SPECIFIED:	NAME	DATE	ALUMINUM 0.0635"	
		DIMENSIONS ARE IN INCHES	DRAWN		TITLE:	
		TOLERANCES:	CHECKED		GOTH-2-P31-200W-ORB-WF-DIM-30K	
		FRACTIONAL ±	ENG APPR.		SIZE DWG. NO. REV	
		ANGULAR: MACH ± BEND ±	MFG APPR.		SCALE: 1:5 WEIGHT: SHEET 8 OF 10	
		TWO PLACE DECIMAL ±	Q.A.			
		THREE PLACE DECIMAL ±	COMMENTS:			
		INTERPRET GEOMETRIC TOLERANCING PER:				
		MATERIAL				
NEXT ASSY	USED ON	FINISH				
APPLICATION		DO NOT SCALE DRAWING				

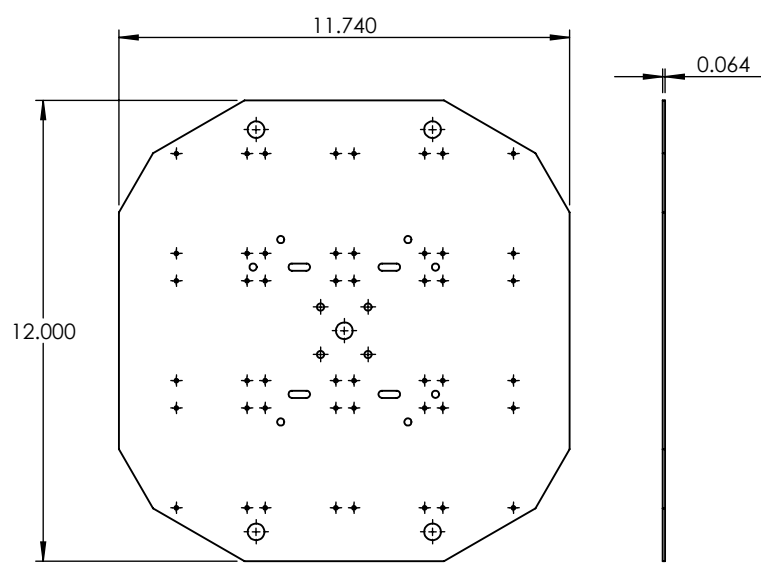
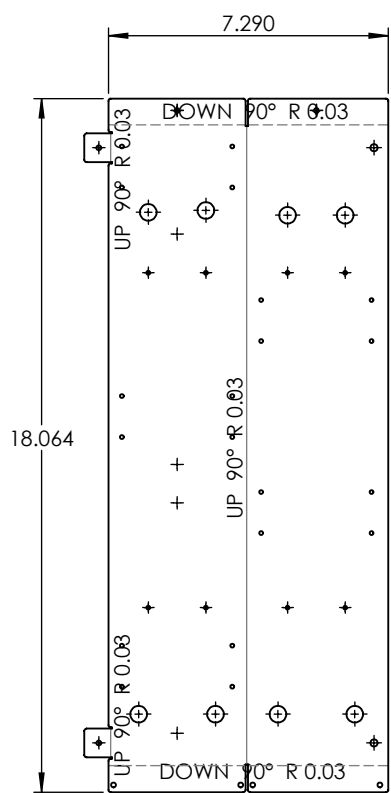
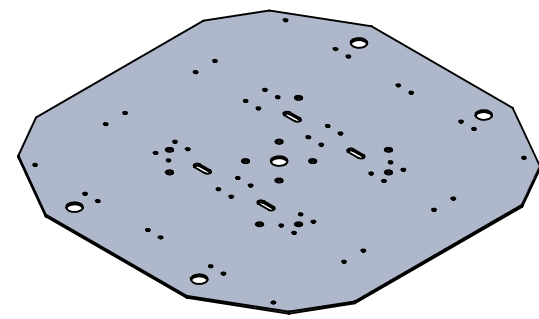
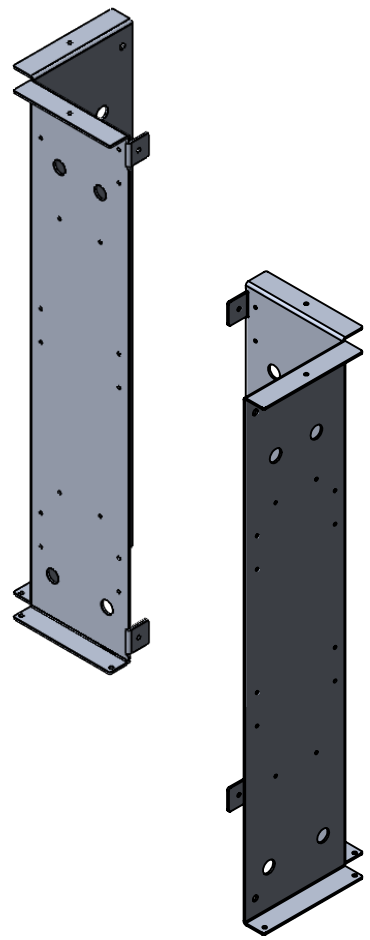
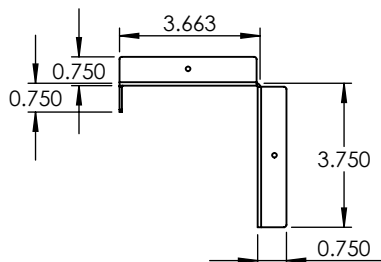

PROPRIETARY AND CONFIDENTIAL
 THE INFORMATION CONTAINED IN THIS DRAWING IS THE SOLE PROPERTY OF <INSERT COMPANY NAME HERE>. ANY REPRODUCTION IN PART OR AS A WHOLE WITHOUT THE WRITTEN PERMISSION OF <INSERT COMPANY NAME HERE> IS PROHIBITED.

		UNLESS OTHERWISE SPECIFIED:	NAME	DATE	ALUMINUM 0.0635"	
		DIMENSIONS ARE IN INCHES	DRAWN		TITLE:	
		TOLERANCES:	CHECKED		GOTH-2-P31-200W-ORB-WF-DIM-30K	
		FRACTIONAL ±	ENG APPR.		SIZE DWG. NO. REV	
		ANGULAR: MACH ± BEND ±	MFG APPR.		SCALE: 1:5 WEIGHT: SHEET 9 OF 10	
		TWO PLACE DECIMAL ±	Q.A.			
		THREE PLACE DECIMAL ±	COMMENTS:			
		INTERPRET GEOMETRIC TOLERANCING PER:				
		MATERIAL				
NEXT ASSY	USED ON	FINISH				
APPLICATION		DO NOT SCALE DRAWING				

5

4

3

2

1

ITEM NO.	PART NUMBER	DESCRIPTION	QTY.
1	10" SWIVEL CANOPY	SPUN ALUMINUM 0.080"	1

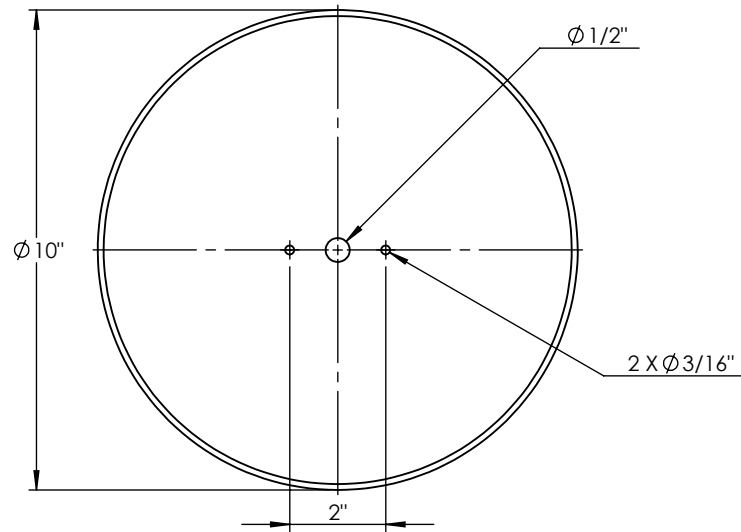
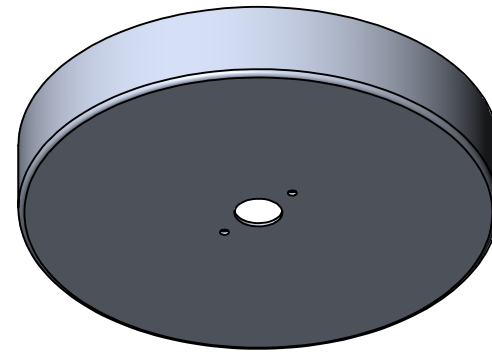
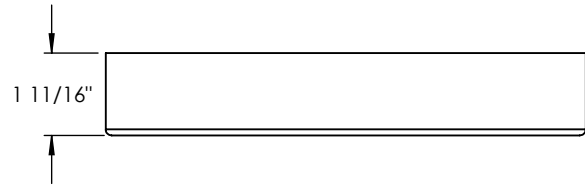
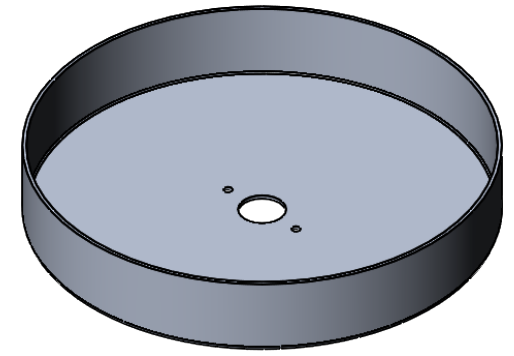

PROPRIETARY AND CONFIDENTIAL
 THE INFORMATION CONTAINED IN THIS DRAWING IS THE SOLE PROPERTY OF <INSERT COMPANY NAME HERE>. ANY REPRODUCTION IN PART OR AS A WHOLE WITHOUT THE WRITTEN PERMISSION OF <INSERT COMPANY NAME HERE> IS PROHIBITED.

		UNLESS OTHERWISE SPECIFIED:	NAME	DATE	SPUN ALUMINUM 0.080"	
		DIMENSIONS ARE IN INCHES	DRAWN		TITLE:	
		TOLERANCES:	CHECKED		GOTH-2-P31-200W-ORB-WF-DIM-30K	
		FRACTIONAL ±	ENG APPR.		SIZE DWG. NO. REV	
		ANGULAR: MACH ± BEND ±	MFG APPR.		A	
		TWO PLACE DECIMAL ±	Q.A.		SCALE: 1:4 WEIGHT: SHEET 10 OF 10	
		THREE PLACE DECIMAL ±	COMMENTS:			
		INTERPRET GEOMETRIC TOLERANCING PER:				
		MATERIAL				
NEXT ASSY	USED ON	FINISH				
APPLICATION		DO NOT SCALE DRAWING				