

EVERGREEN LIGHTING

ALL BEND RADIUS .030"

APPLICATION

DO NOT SCALE DRAWING

UNLESS OTHERWISE SPECIFIED:

DIMENSIONS ARE IN INCHES
 TOLERANCES:
 FRACTIONAL ± .003
 ANGULAR: MACH ± .01 BEND ±
 TWO PLACE DECIMAL ±
 THREE PLACE DECIMAL ±.001

INTERPRET GEOMETRIC
 TOLERANCING PER:

MATERIAL

FINISH

NAME

DATE

DRAWN

CHECKED

ENG APPR.

MFG APPR.

Q.A.

COMMENTS:

TITLE:

SYL-B-MD-44-12W-TBR-WF-DIM-41K

SIZE DWG. NO.

REV

A TICKET 24217

SCALE: 1:10 WEIGHT:

SHEET 1 OF 9

5

4

3

2

1

ITEM NO.	PART NUMBER	DESCRIPTION	QTY.	CUT
1	SYL-B-MD-44-12W-TBR-WF-DIM-41K-POST	5"X5" SQUARE ALUMINUM POST	1	
2	SYL-B-MD-44-12W-TBR-WF-DIM-41K-PLATE ACCENT	ALUMINUM 0.500" PLATE	2	
3	SYL-B-MD-44-12W-TBR-WF-DIM-41K-PLATE ACCENT SHORT	ALUMINUM 0.500" PLATE	2	
4	SYL-B-MD-44-12W-TBR-WF-DIM-41K-BOTTOM TUBE SEAT	ALUMINUM 0.250" PLATE	1	
5	SYL-B-MD-44-12W-TBR-WF-DIM-41K-ANCHOR BASE	ALUMINUM 0.125" PLATE	1	
6	SYL-B-MD-44-12W-TBR-WF-DIM-41K-DRIVER BRACKET	ALUMINUM 0.0635"	1	
7	SYL-B-MD-44-12W-TBR-WF-DIM-41K-BRACKET SPACER	ALUMINUM 0.0635"	1	
8	SYL-B-MD-44-12W-TBR-WF-DIM-41K-DRIVER BOX	ALUMINUM 0.0635"	1	
9	SYL-B-MD-44-12W-TBR-WF-DIM-41K-TUBE BRACKET	ALUMINUM 0.0635"	1	
10	SYL-B-MD-44-12W-TBR-WF-DIM-41K-SQUARE TUBE	1" SQUARE ALUMINUM TUBE	1	
11	SYL-B-MD-44-12W-TBR-WF-DIM-41K-ACRYLIC	ACRYLIC	1	
12	DS-15W-350C1542010-3001	DRIVER	3	
13	AltalLED PN105B-11-2.5-SS	LED	6	
15	AltalLED_PCN_D1000_105B	LED	1	

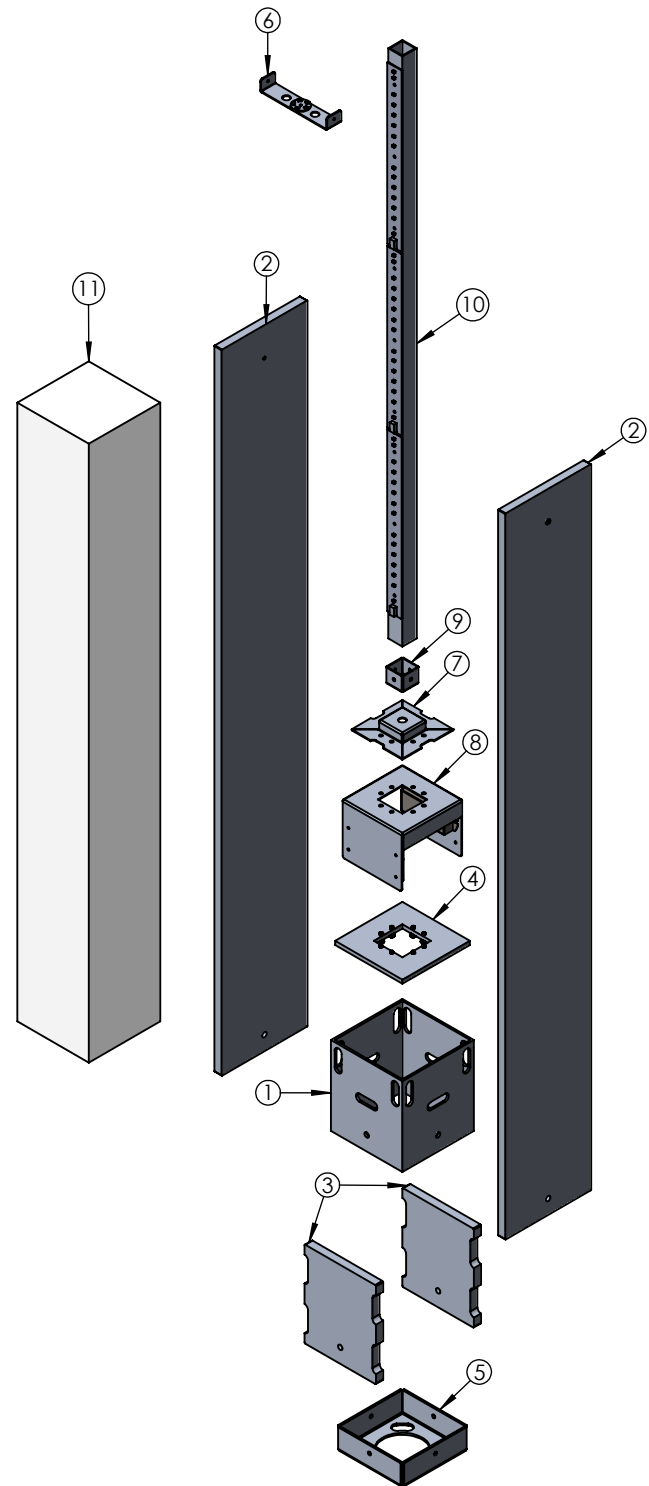

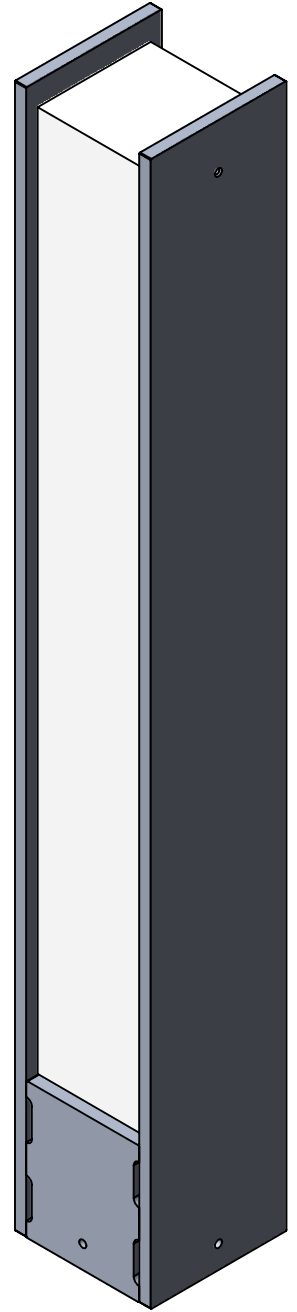
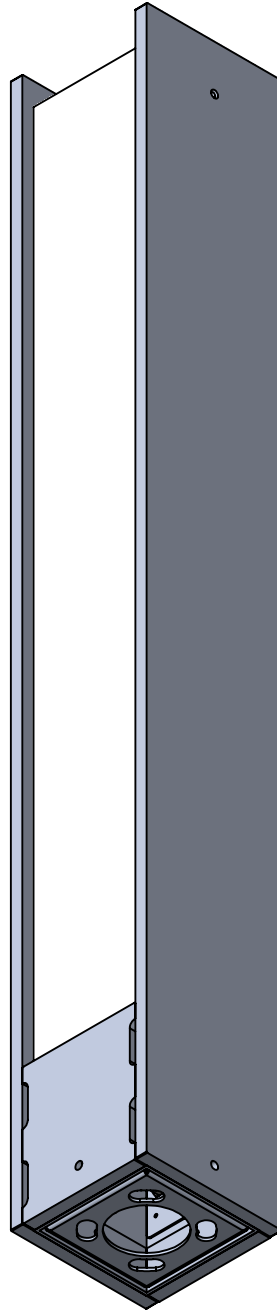
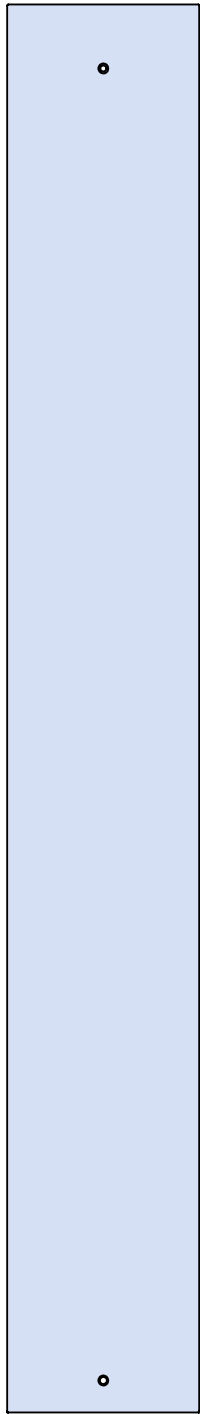
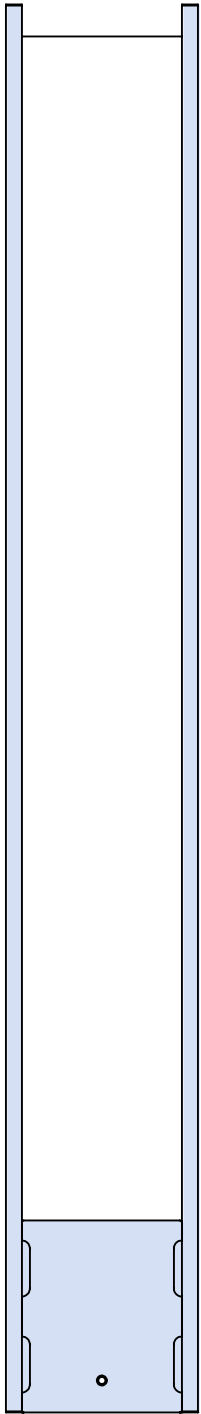

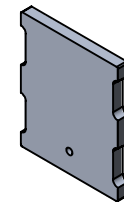
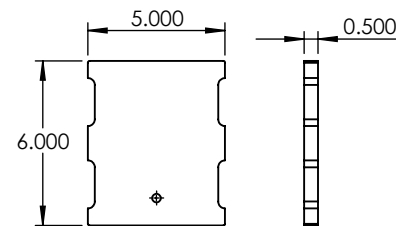
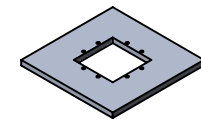
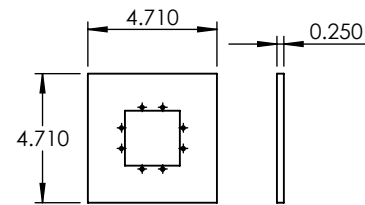
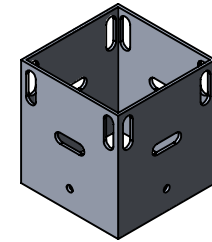
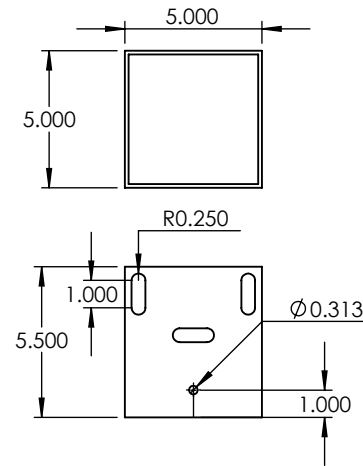
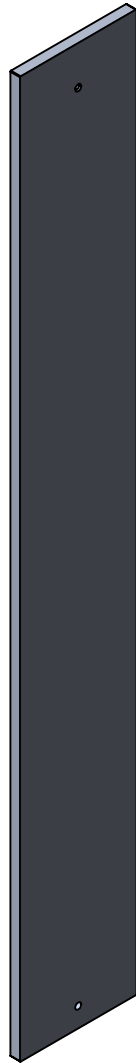
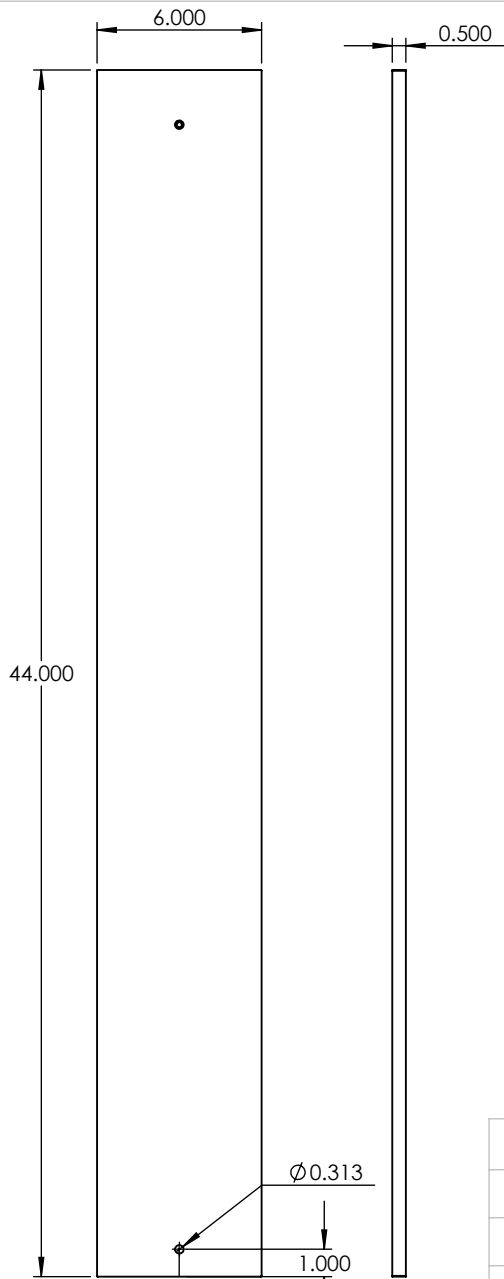

PROPRIETARY AND CONFIDENTIAL
 THE INFORMATION CONTAINED IN THIS DRAWING IS THE SOLE PROPERTY OF <INSERT COMPANY NAME HERE>. ANY REPRODUCTION IN PART OR AS A WHOLE WITHOUT THE WRITTEN PERMISSION OF <INSERT COMPANY NAME HERE> IS PROHIBITED.

		UNLESS OTHERWISE SPECIFIED:	NAME	DATE
		DIMENSIONS ARE IN INCHES	DRAWN	
		TOLERANCES:	CHECKED	
		FRACTIONAL ±	ENG APPR.	
		ANGULAR: MACH ± BEND ±	MFG APPR.	
		TWO PLACE DECIMAL ±	Q.A.	
		THREE PLACE DECIMAL ±	COMMENTS:	
		INTERPRET GEOMETRIC TOLERANCING PER:		
		MATERIAL		
NEXT ASSY	USED ON	FINISH		
APPLICATION		DO NOT SCALE DRAWING		

ALUMINUM 0.500" PLATE

TITLE:
 SYL-B-MD-44-12W-TBR-WF-DIM-41K

SIZE DWG. NO. REV
A

SCALE: 1:7 WEIGHT: SHEET 4 OF 9

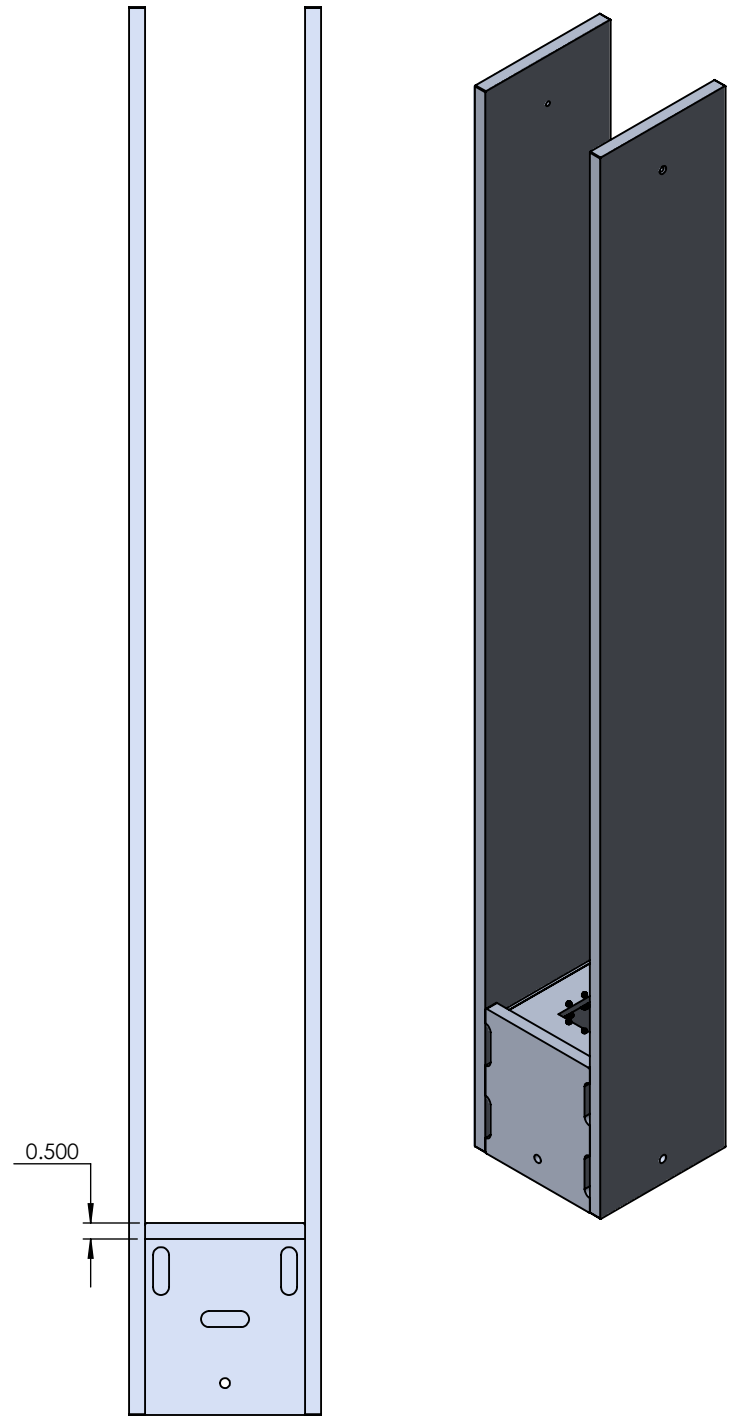
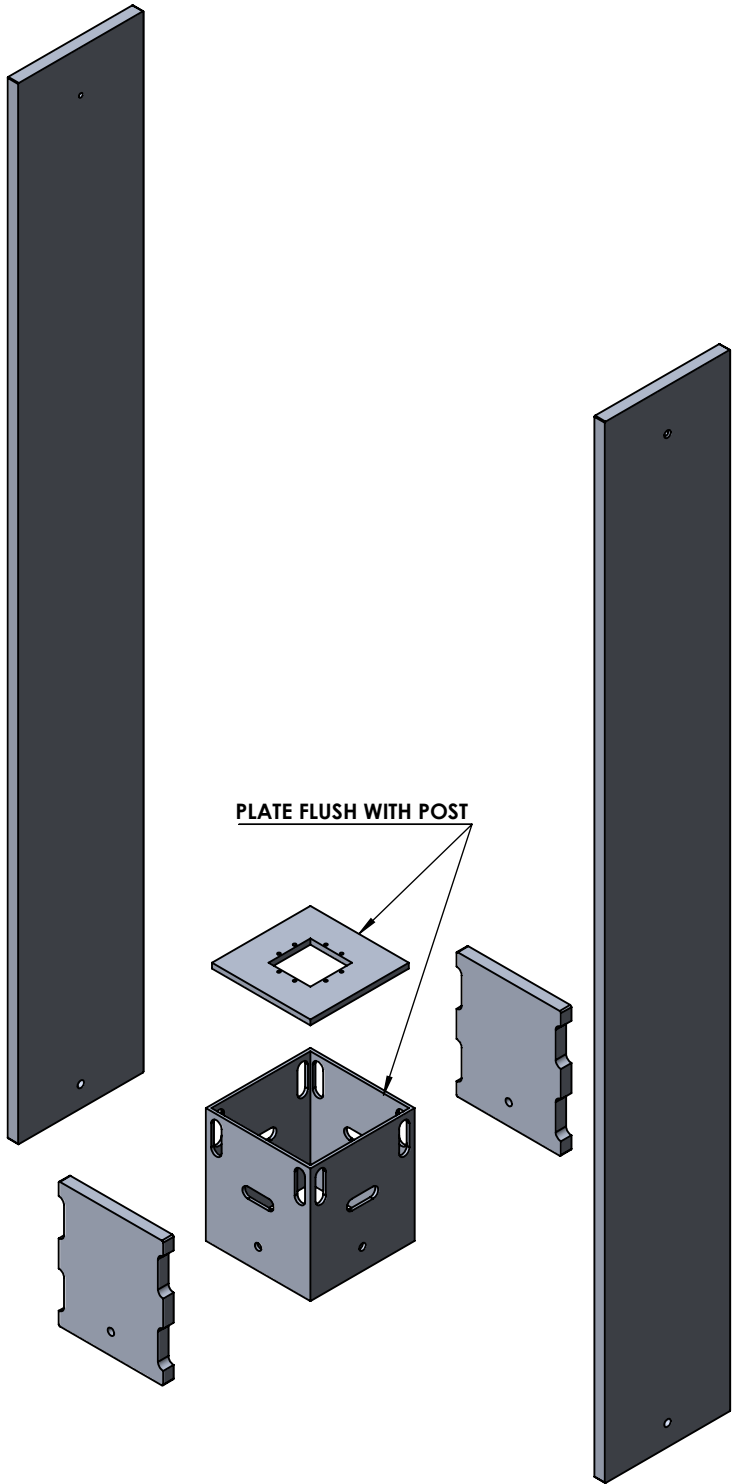

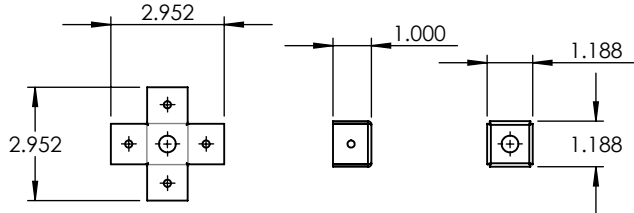
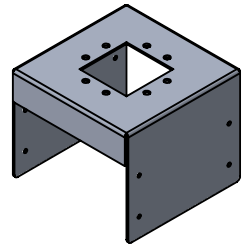
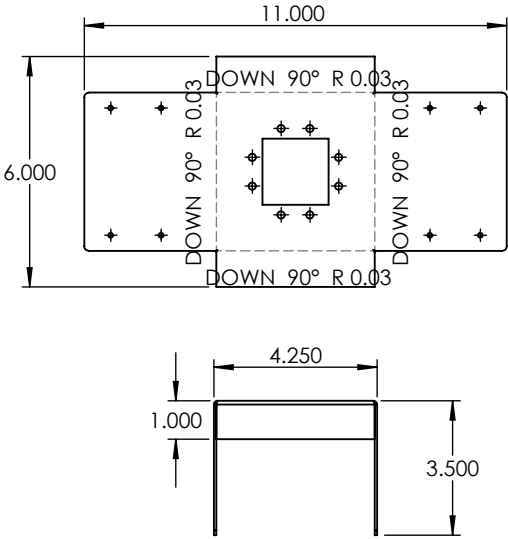
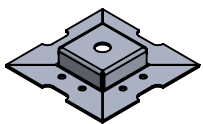
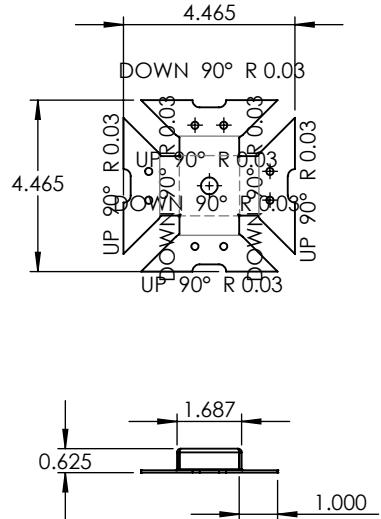
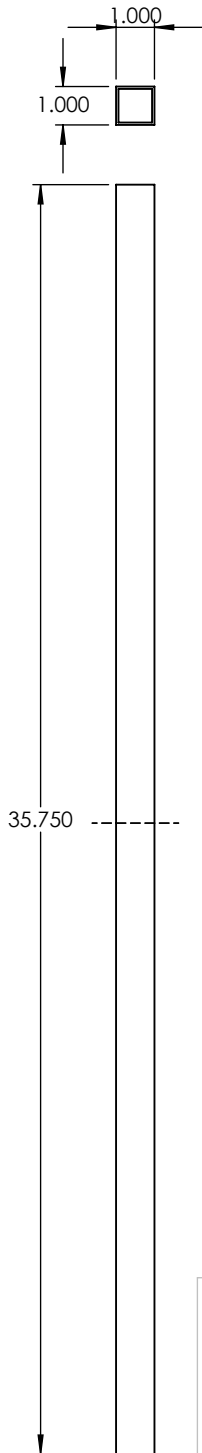

PROPRIETARY AND CONFIDENTIAL
 THE INFORMATION CONTAINED IN THIS DRAWING IS THE SOLE PROPERTY OF <INSERT COMPANY NAME HERE>. ANY REPRODUCTION IN PART OR AS A WHOLE WITHOUT THE WRITTEN PERMISSION OF <INSERT COMPANY NAME HERE> IS PROHIBITED.

		UNLESS OTHERWISE SPECIFIED:	NAME	DATE
		DIMENSIONS ARE IN INCHES	DRAWN	
		TOLERANCES:	CHECKED	
		FRACTIONAL ±	ENG APPR.	
		ANGULAR: MACH ± BEND ±	MFG APPR.	
		TWO PLACE DECIMAL ±	Q.A.	
		THREE PLACE DECIMAL ±	COMMENTS:	
		INTERPRET GEOMETRIC TOLERANCING PER:		
		MATERIAL		
NEXT ASSY	USED ON	FINISH		
APPLICATION		DO NOT SCALE DRAWING		

1" SQUARE ALUMINUM TUBE		
TITLE:		
SYL-B-MD-44-12W-TBR-WF-DIM-41K		
SIZE	DWG. NO.	REV
A		
SCALE: 1:5	WEIGHT:	SHEET 6 OF 9

5

4

3

2

1

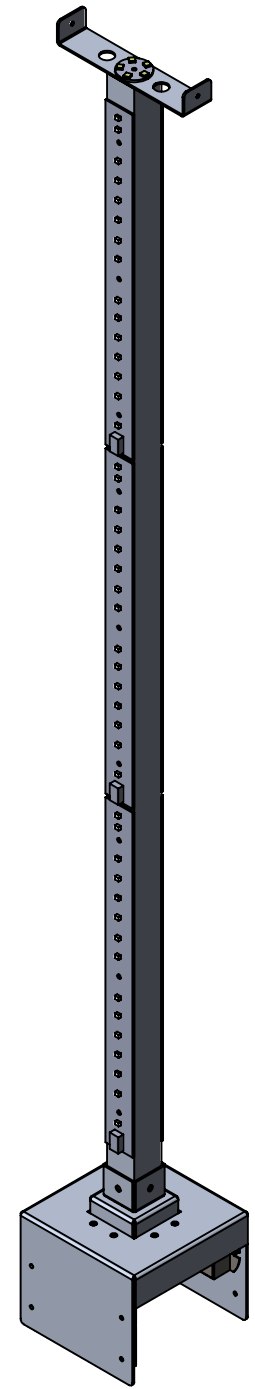
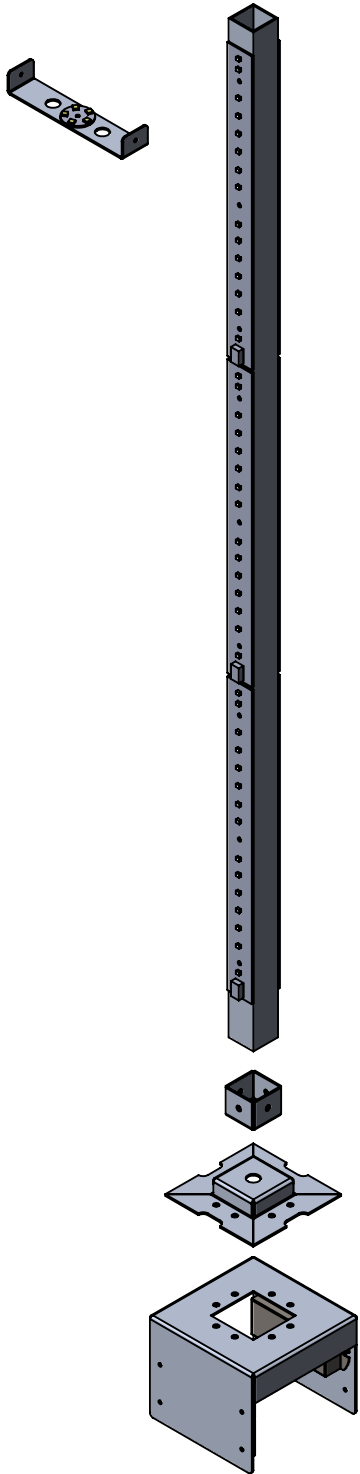

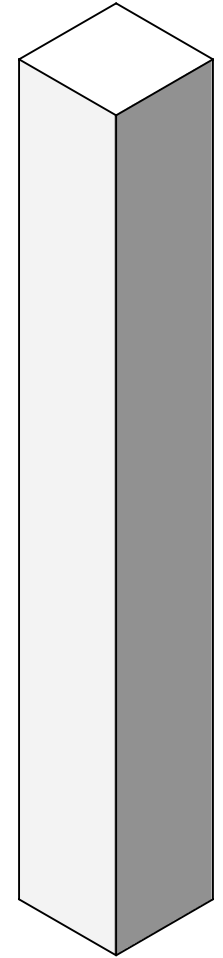
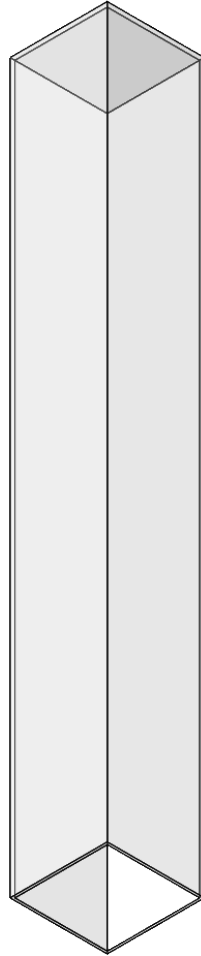
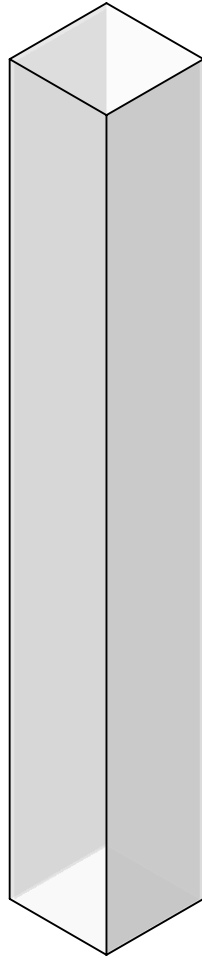
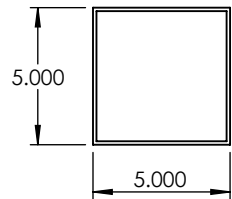
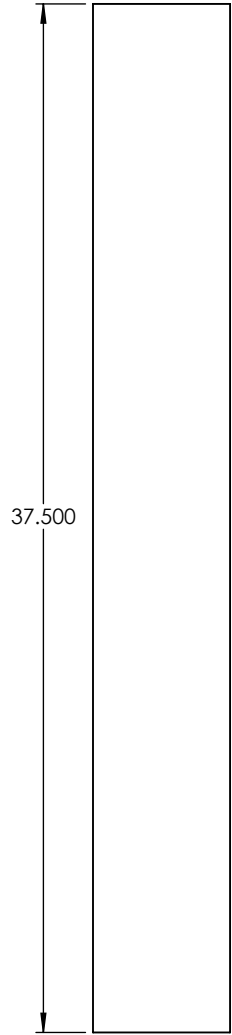

PROPRIETARY AND CONFIDENTIAL
 THE INFORMATION CONTAINED IN THIS DRAWING IS THE SOLE PROPERTY OF <INSERT COMPANY NAME HERE>. ANY REPRODUCTION IN PART OR AS A WHOLE WITHOUT THE WRITTEN PERMISSION OF <INSERT COMPANY NAME HERE> IS PROHIBITED.

		UNLESS OTHERWISE SPECIFIED:		NAME	DATE	ACRYLIC		
		DIMENSIONS ARE IN INCHES TOLERANCES: FRACTIONAL ± ANGULAR: MACH ± BEND ± TWO PLACE DECIMAL ± THREE PLACE DECIMAL ±	DRAWN					TITLE:
		INTERPRET GEOMETRIC TOLERANCING PER:	CHECKED			SYL-B-MD-44-12W-TBR-WF-DIM-41K		
		MATERIAL	ENG APPR.			Q.A.		
		FINISH	MFG APPR.			COMMENTS:		
NEXT ASSY	USED ON					SIZE	DWG. NO.	REV
APPLICATION		DO NOT SCALE DRAWING				A		
						SCALE: 1:7	WEIGHT:	SHEET 8 OF 9

5

4

3

2

1

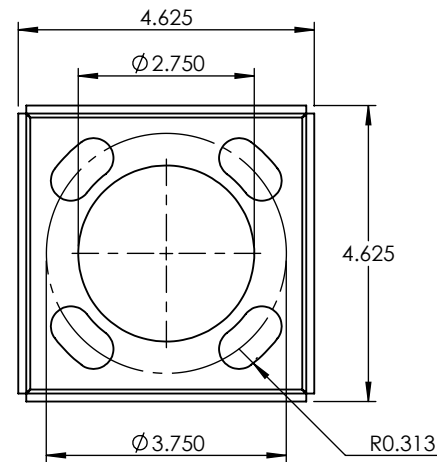
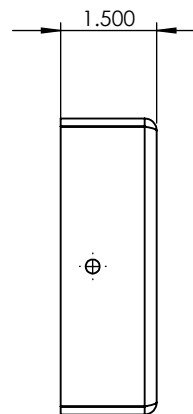
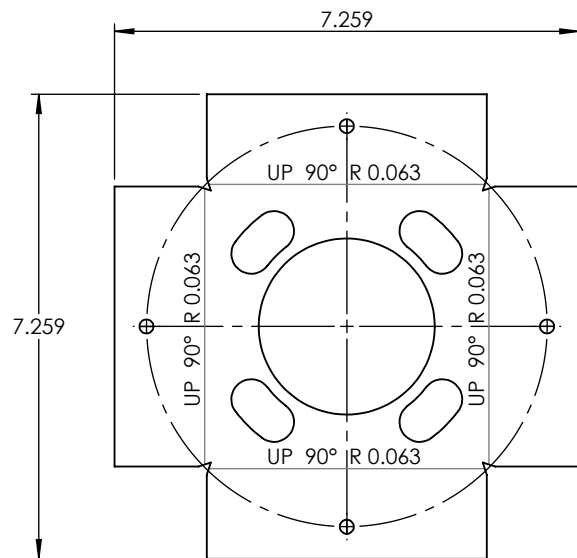
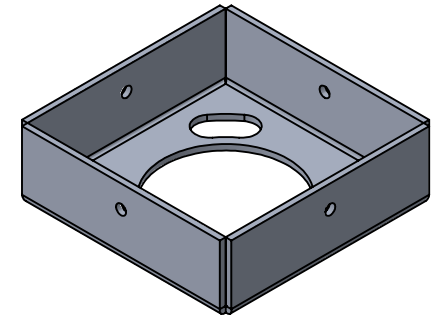

PROPRIETARY AND CONFIDENTIAL
 THE INFORMATION CONTAINED IN THIS DRAWING IS THE SOLE PROPERTY OF <INSERT COMPANY NAME HERE>. ANY REPRODUCTION IN PART OR AS A WHOLE WITHOUT THE WRITTEN PERMISSION OF <INSERT COMPANY NAME HERE> IS PROHIBITED.

		UNLESS OTHERWISE SPECIFIED:		NAME	DATE	ALUMINUM 0.125"	
		DIMENSIONS ARE IN INCHES TOLERANCES: FRACTIONAL ± ANGULAR: MACH ± BEND ± TWO PLACE DECIMAL ± THREE PLACE DECIMAL ±		DRAWN		TITLE:	
		INTERPRET GEOMETRIC TOLERANCING PER:		CHECKED		SYL-B-MD-44-12W-TBR-WF-DIM-41K	
		MATERIAL		ENG APPR.		SIZE	DWG. NO.
	NEXT ASSY	FINISH		MFG APPR.		A	REV
	USED ON			Q.A.		SCALE: 1:3	WEIGHT:
	APPLICATION	DO NOT SCALE DRAWING		COMMENTS:			SHEET 9 OF 9