

| ITEM NO. | PART NUMBER | DESCRIPTION | QTY. | CUT |
|----------|---|-----------------------|------|-----|
| 1 | AC-B-ARMD42"-36W-AB-CFA-DIM-41K-VERTICAL REC TUBE | 8"x4" ALUMINUM TUBE | 1 | |
| 2 | AC-B-ARMD42"-36W-AB-CFA-DIM-41K-ROLLED TOP | ALUMINUM 0.125" PLATE | 1 | |
| 3 | AC-B-ARMD42"-36W-AB-CFA-DIM-41K-TOP CAP | ALUMINUM 0.125" PLATE | 2 | |
| 4 | AC-B-ARMD42"-36W-AB-CFA-DIM-41K-BOTTOM PLATE | ALUMINUM 0.125" PLATE | 1 | |
| 5 | AC-B-ARMD42"-36W-AB-CFA-DIM-41K-LENS PLATE | ALUMINUM 0.125" PLATE | 1 | |
| 6 | AC-B-ARMD42"-36W-AB-CFA-DIM-41K-ANCHOR PLATE | ALUMINUM 0.500" PLATE | 1 | |
| 7 | AC-B-ARMD42"-36W-AB-CFA-DIM-41K-REGRESSED PLATE | ALUMINUM 0.0635" | 1 | |
| 8 | AC-B-ARMD42"-36W-AB-CFA-DIM-41K-DRIVER BRACKET | ALUMINUM 0.0635" | 1 | |
| 9 | AC-B-ARMD42"-36W-AB-CFA-DIM-41K-LED PLATE | ALUMINUM 0.0635" | 1 | |
| 11 | AC-B-ARMD42"-36W-AB-CFA-DIM-41K-ANCHOR BRACKET | ALUMINUM 0.0635" | 2 | |
| 12 | AC-B-ARMD42"-36W-AB-CFA-DIM-41K-ANCHOR COVER | ALUMINUM 0.0635" | 2 | |
| 13 | AC-B-ARMD42"-36W-AB-CFA-DIM-41K-ACRYLIC | ACRYLIC | 1 | |
| 14 | AC-B-ARMD42"-36W-AB-CFA-DIM-41K-COVER TAB | 25 GAUGE | 4 | |
| 15 | Altal LED PN1019 SHIM PLATE | ALUMINUM 0.125" PLATE | 4 | |
| 16 | KTLD-25-UV-700-VDIM-LA1 | DRIVER | 2 | |
| 17 | Altal LED PN1019 RevC | LED | 4 | |

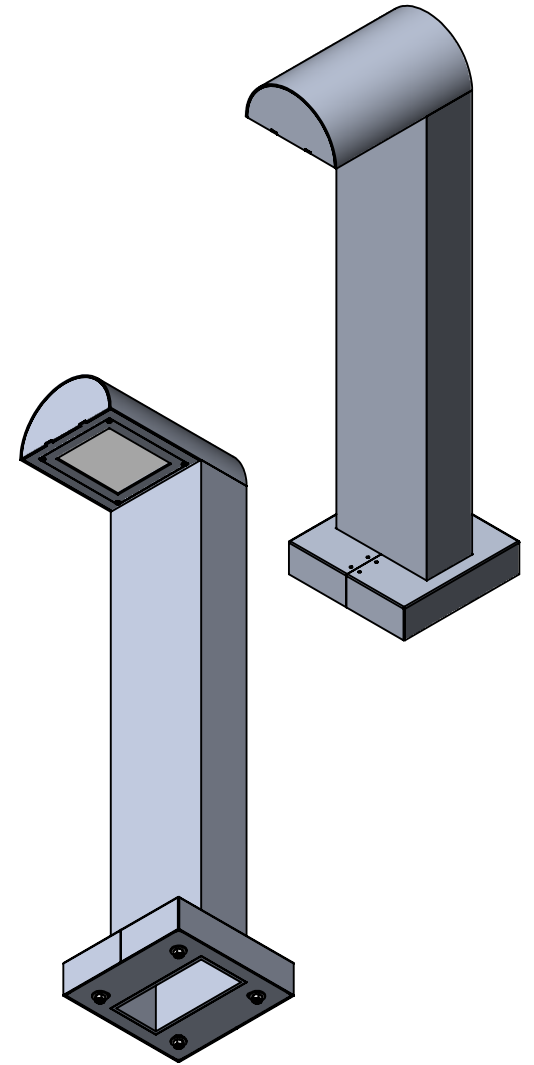
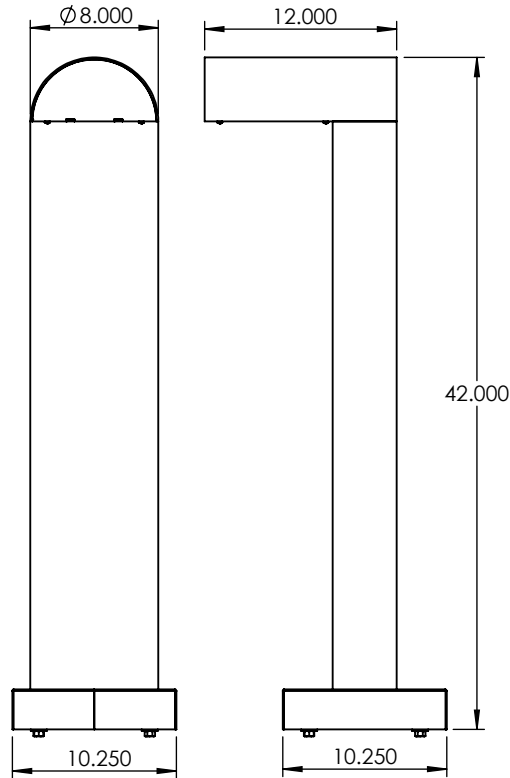
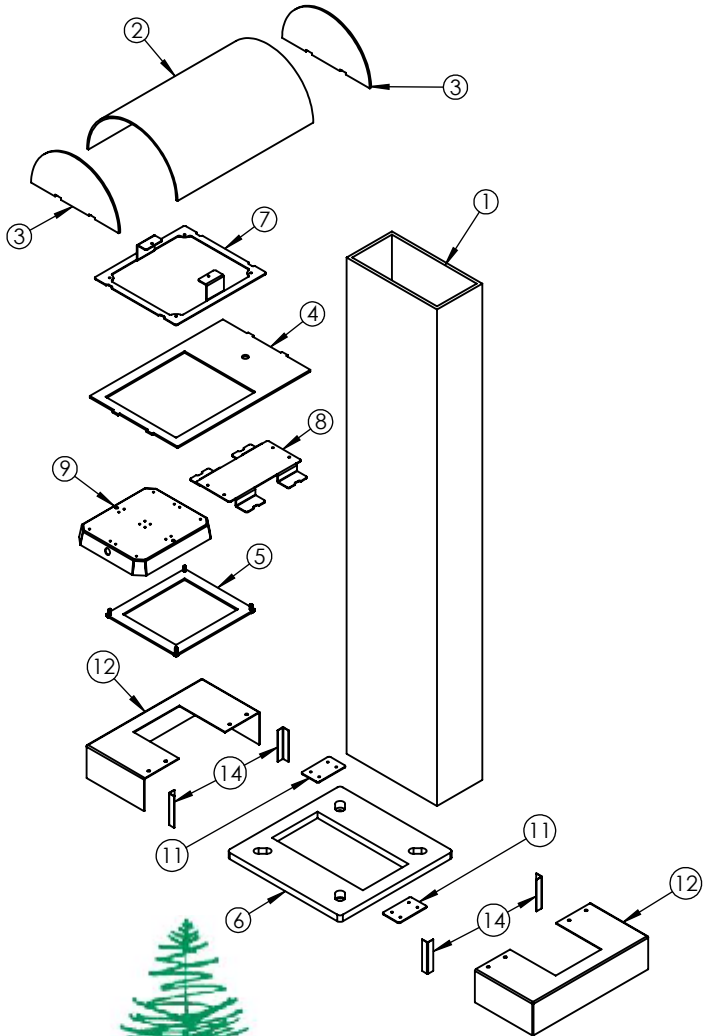

ALL BEND RADIUS .030"

UNLESS OTHERWISE SPECIFIED:

DIMENSIONS ARE IN INCHES
 TOLERANCES:
 FRACTIONAL ± .003
 ANGULAR: MACH ± .01 BEND ±
 TWO PLACE DECIMAL ±
 THREE PLACE DECIMAL ± .001

INTERPRET GEOMETRIC
 TOLERANCING PER:
 MATERIAL

FINISH

APPLICATION

DO NOT SCALE DRAWING

NAME DATE

DRAWN
 CHECKED
 ENG APPR.
 MFG APPR.

Q.A.
 COMMENTS:

TITLE:

AC-B-ARMD42"-36W-AB-CFA-DIM-41K

SIZE DWG. NO.

A TICKET 24684

REV

SCALE: 1:12 WEIGHT:

SHEET 1 OF 8

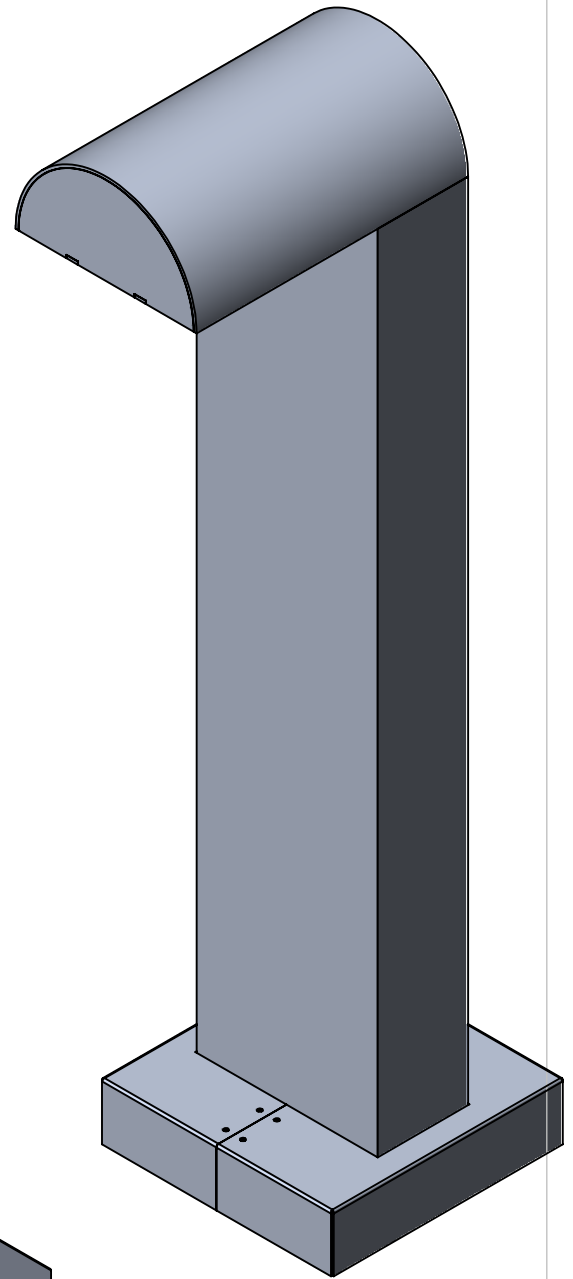
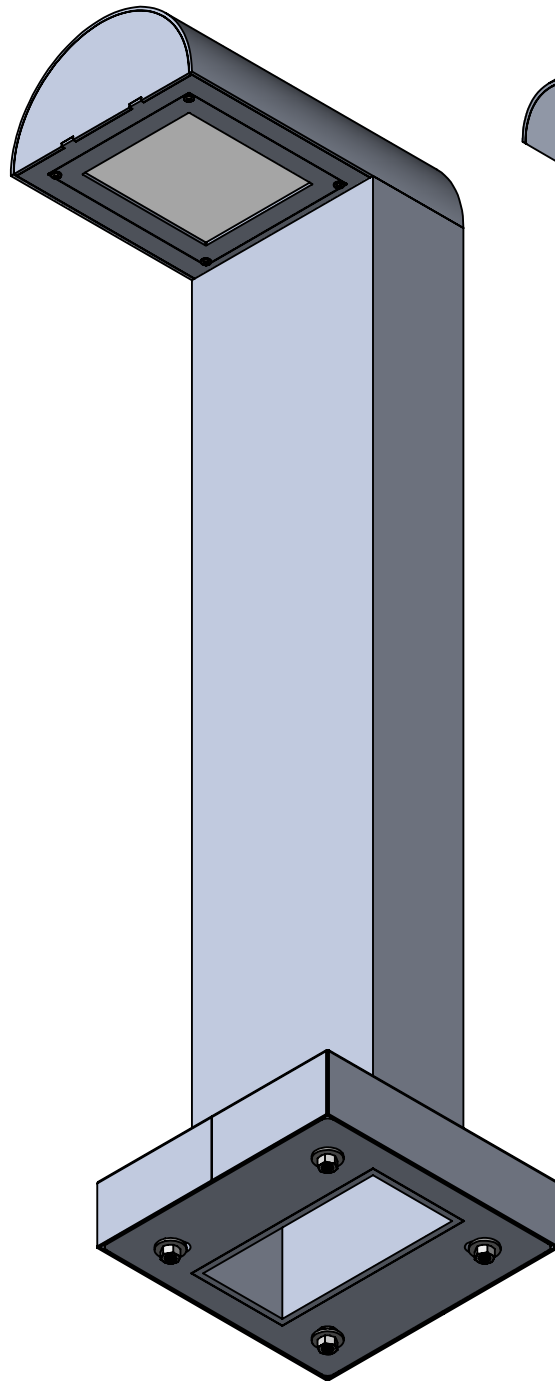
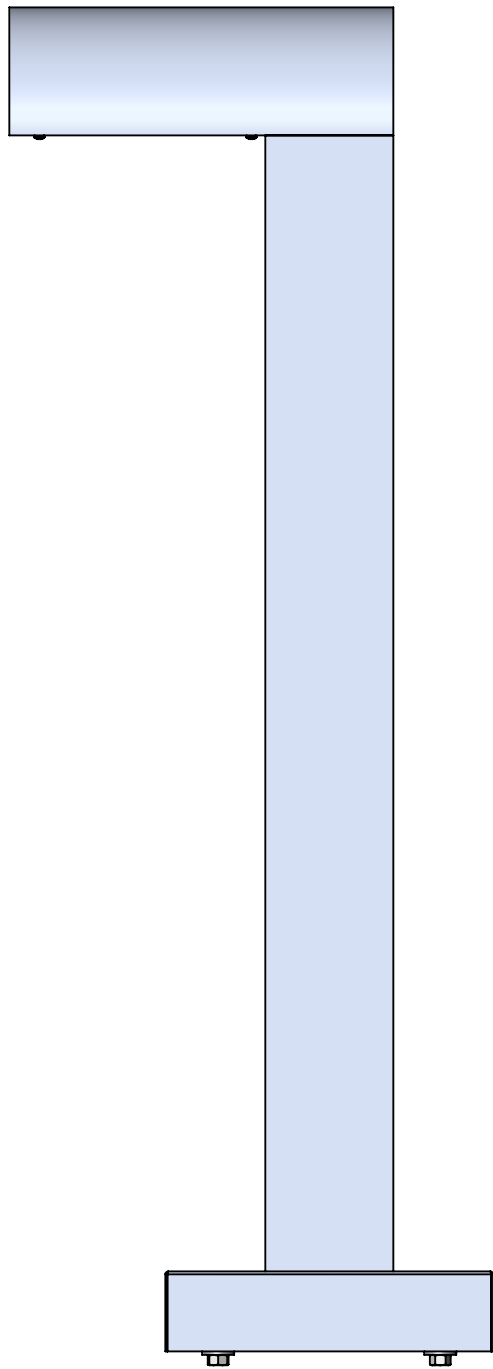
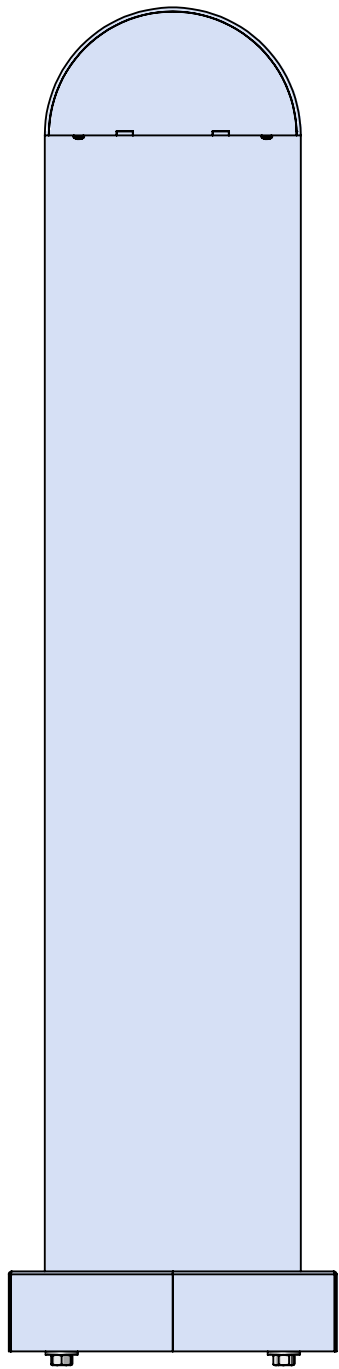

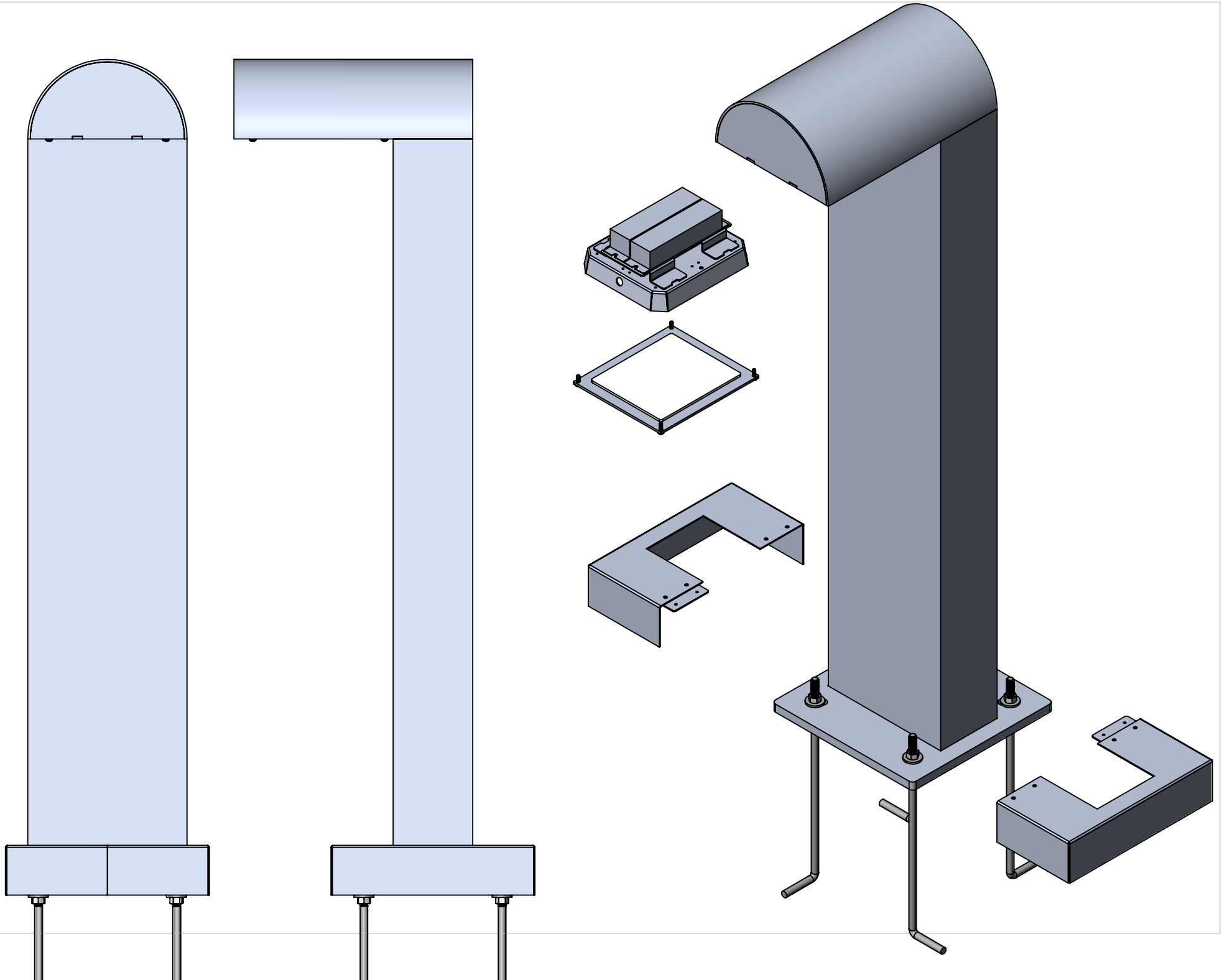

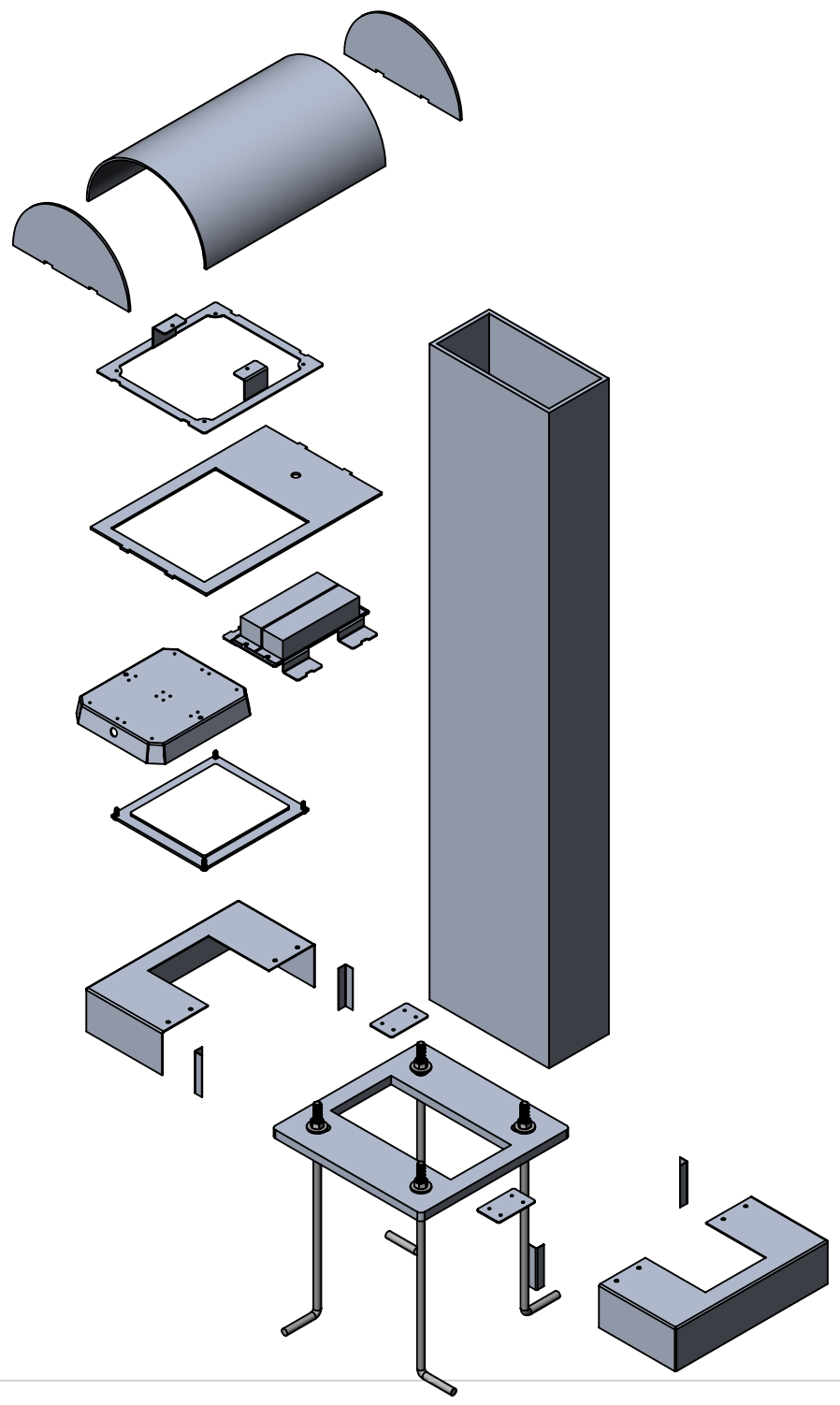

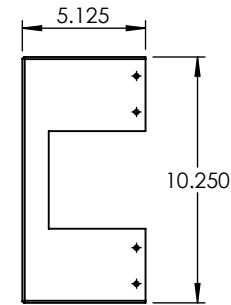
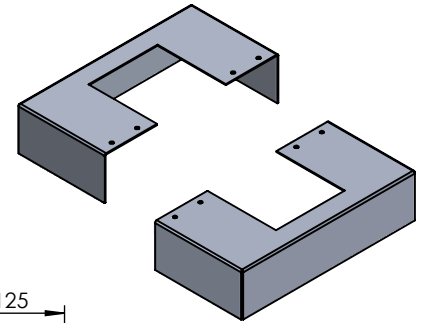
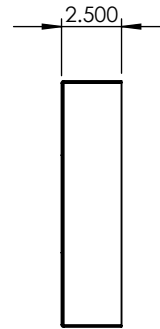
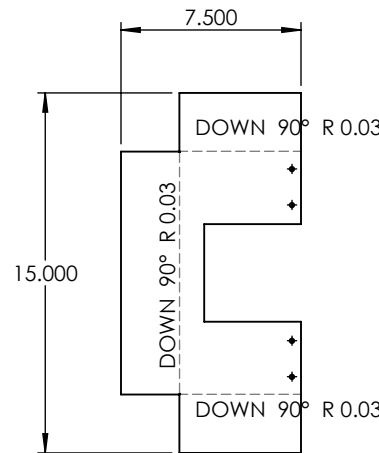
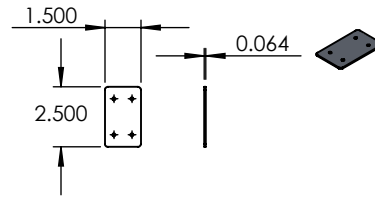
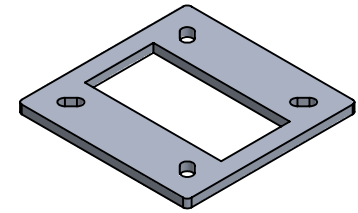
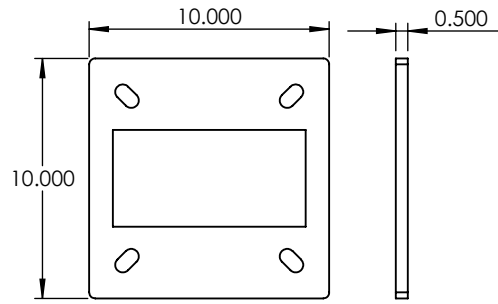
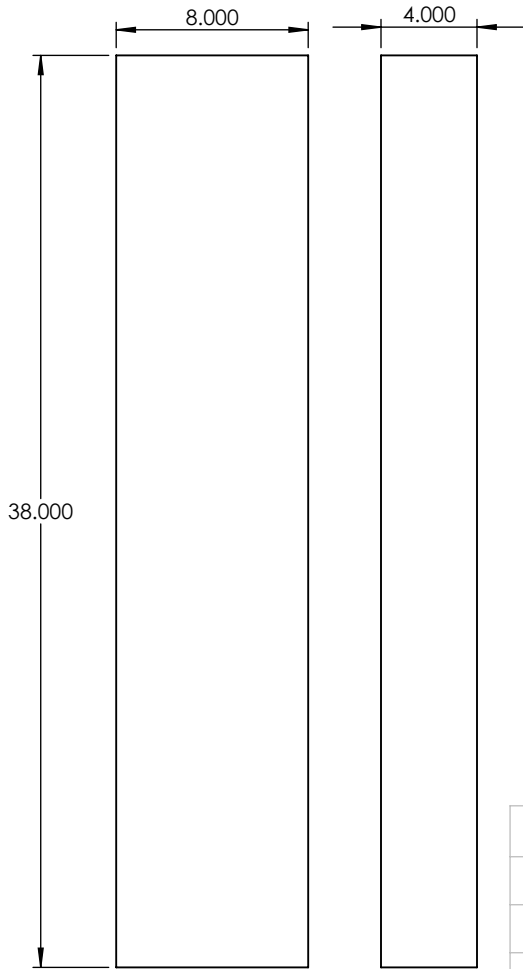
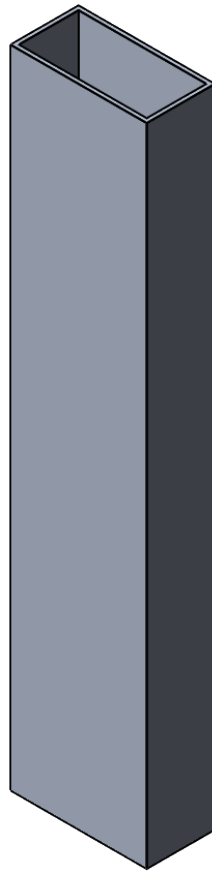

PROPRIETARY AND CONFIDENTIAL
 THE INFORMATION CONTAINED IN THIS DRAWING IS THE SOLE PROPERTY OF <INSERT COMPANY NAME HERE>. ANY REPRODUCTION IN PART OR AS A WHOLE WITHOUT THE WRITTEN PERMISSION OF <INSERT COMPANY NAME HERE> IS PROHIBITED.

| | | | | | |
|-------------|---------|--------------------------------------|-----------|------|------|
| | | UNLESS OTHERWISE SPECIFIED: | | NAME | DATE |
| | | DIMENSIONS ARE IN INCHES | DRAWN | | |
| | | TOLERANCES: | CHECKED | | |
| | | FRACTIONAL ± | ENG APPR. | | |
| | | ANGULAR: MACH ± BEND ± | MFG APPR. | | |
| | | TWO PLACE DECIMAL ± | Q.A. | | |
| | | THREE PLACE DECIMAL ± | COMMENTS: | | |
| | | INTERPRET GEOMETRIC TOLERANCING PER: | | | |
| | | MATERIAL | | | |
| | | FINISH | | | |
| NEXT ASSY | USED ON | | | | |
| APPLICATION | | DO NOT SCALE DRAWING | | | |

8"x4" ALUMINUM TUBE

TITLE:
 AC-B-ARMD42"-36W-AB-CFA-DIM-41K

| | | |
|------------|----------|--------------|
| SIZE | DWG. NO. | REV |
| A | | |
| SCALE: 1:8 | WEIGHT: | SHEET 5 OF 8 |

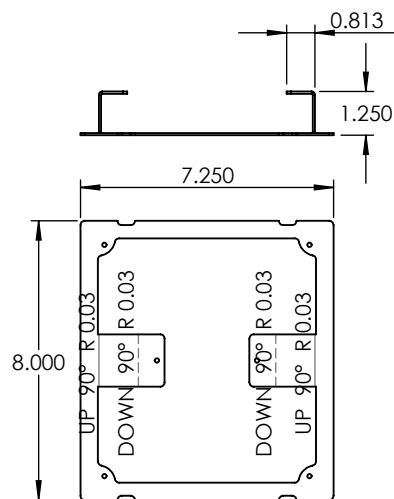
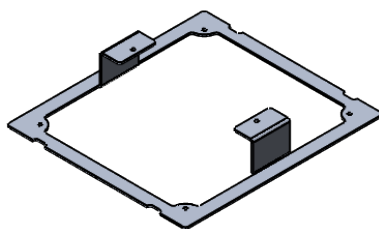
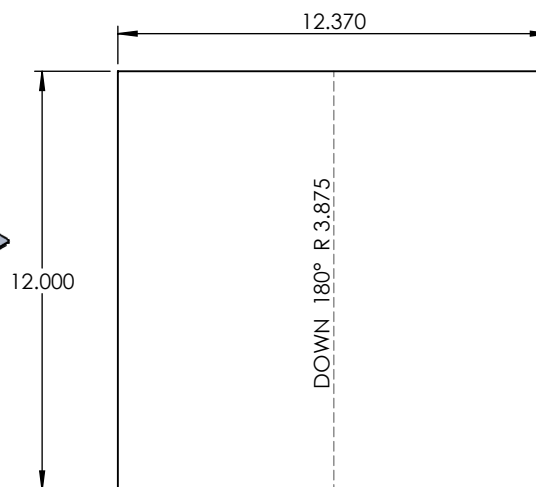
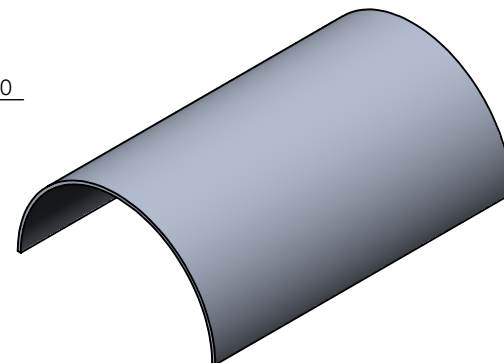
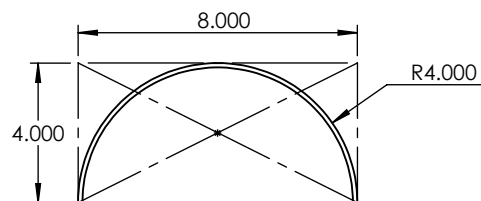
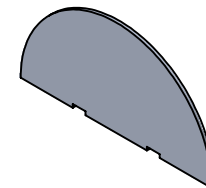
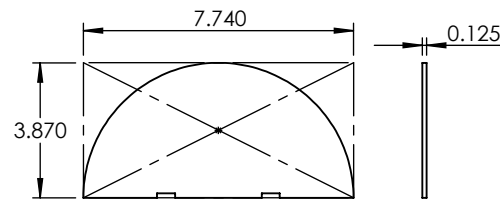
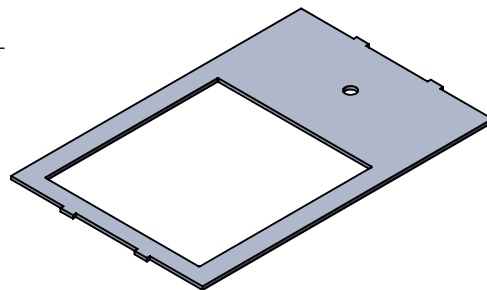
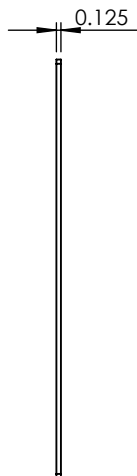
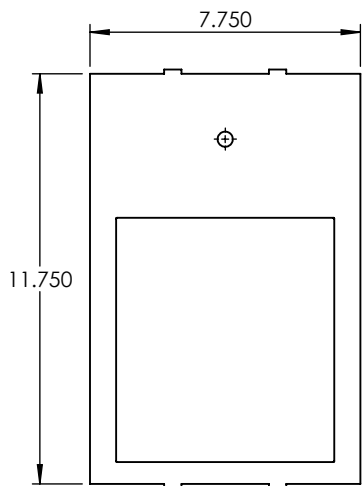

| | | | | | |
|--|--|----------------------|------|---------------------------------|--|
| UNLESS OTHERWISE SPECIFIED: | | NAME | DATE | ALUMINUM 0.125" PLATE | |
| DIMENSIONS ARE IN INCHES TOLERANCES: FRACTIONAL ± ANGULAR: MACH ± BEND ± TWO PLACE DECIMAL ± THREE PLACE DECIMAL ± | | DRAWN | | | |
| INTERPRET GEOMETRIC TOLERANCING PER: | | CHECKED | | AC-B-ARMD42"-36W-AB-CFA-DIM-41K | |
| MATERIAL | | ENG APPR. | | | |
| FINISH | | MFG APPR. | | SIZE DWG. NO. REV | |
| NEXT ASSY | | Q.A. | | SCALE: 1:5 WEIGHT: SHEET 6 OF 8 | |
| USED ON | | COMMENTS: | | | |
| APPLICATION | | DO NOT SCALE DRAWING | | | |

PROPRIETARY AND CONFIDENTIAL
THE INFORMATION CONTAINED IN THIS DRAWING IS THE SOLE PROPERTY OF <INSERT COMPANY NAME HERE>. ANY REPRODUCTION IN PART OR AS A WHOLE WITHOUT THE WRITTEN PERMISSION OF <INSERT COMPANY NAME HERE> IS PROHIBITED.

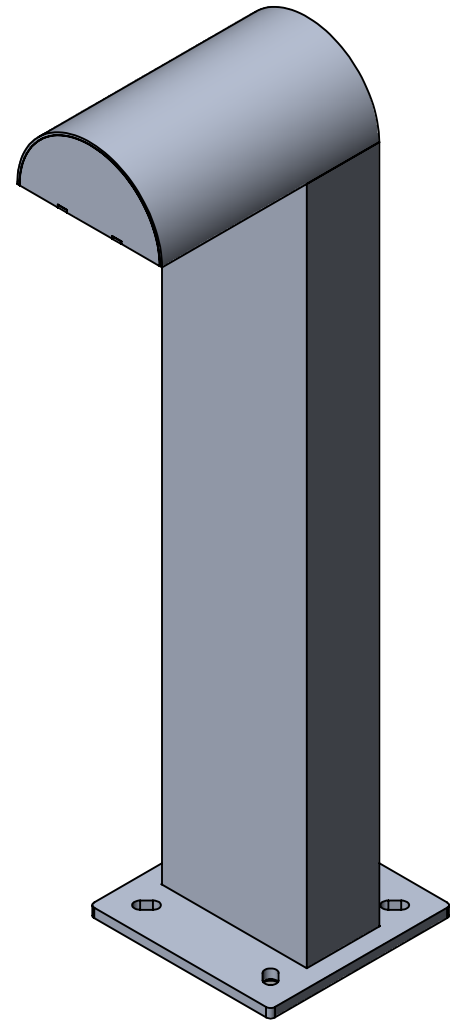
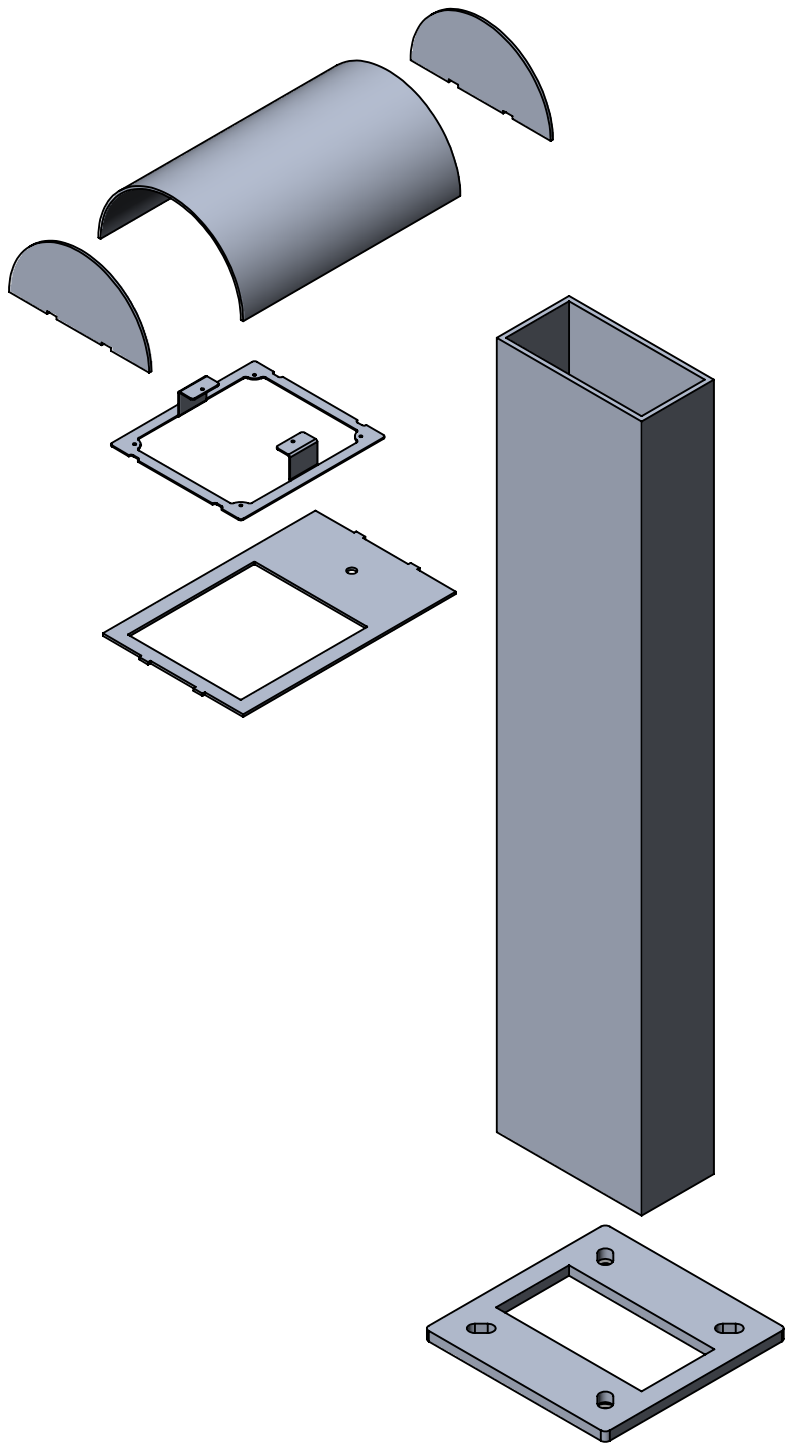

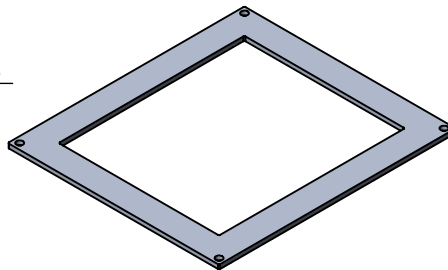
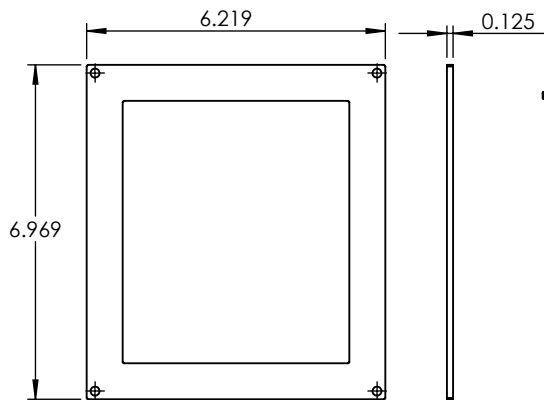
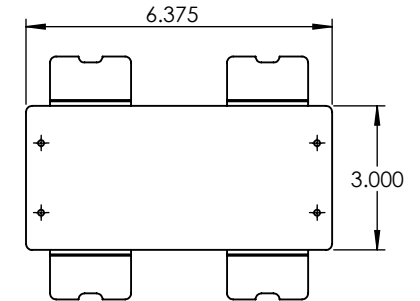
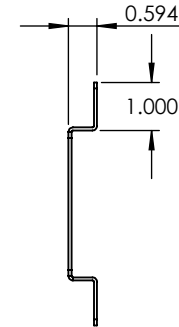
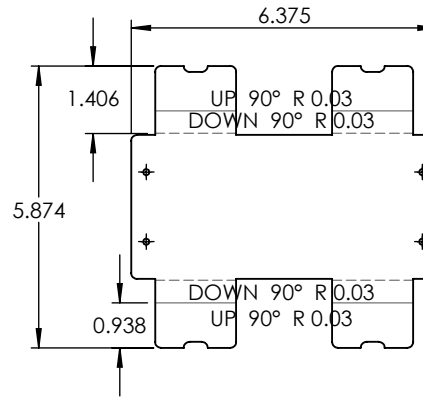
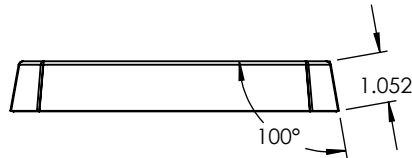
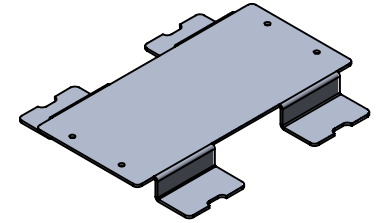
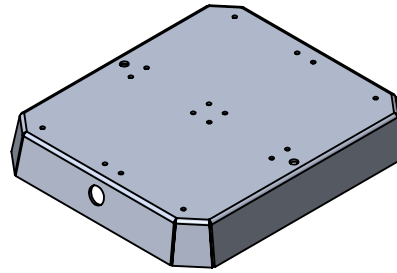
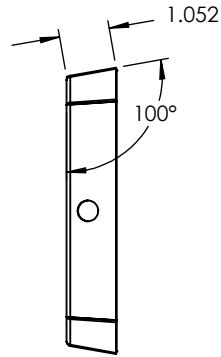
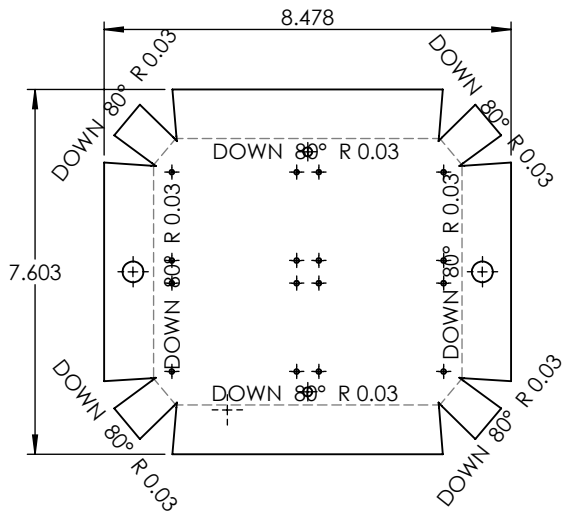

UNLESS OTHERWISE SPECIFIED:

DIMENSIONS ARE IN INCHES
 TOLERANCES:
 FRACTIONAL ±
 ANGULAR: MACH ± BEND ±
 TWO PLACE DECIMAL ±
 THREE PLACE DECIMAL ±

INTERPRET GEOMETRIC
 TOLERANCING PER:

MATERIAL

FINISH

DO NOT SCALE DRAWING

NAME

DATE

ALUMINUM 0.125" PLATE

TITLE:

AC-B-ARMD42"-36W-AB-CFA-DIM-41K

PROPRIETARY AND CONFIDENTIAL

THE INFORMATION CONTAINED IN THIS DRAWING IS THE SOLE PROPERTY OF <INSERT COMPANY NAME HERE>. ANY REPRODUCTION IN PART OR AS A WHOLE WITHOUT THE WRITTEN PERMISSION OF <INSERT COMPANY NAME HERE> IS PROHIBITED.

| | | |
|-------------|---------|----------------------|
| NEXT ASSY | USED ON | FINISH |
| APPLICATION | | DO NOT SCALE DRAWING |

| | | |
|-----------|------|------|
| DRAWN | NAME | DATE |
| CHECKED | | |
| ENG APPR. | | |
| MFG APPR. | | |
| Q.A. | | |
| COMMENTS: | | |

| | | |
|------------|----------|--------------|
| SIZE | DWG. NO. | REV |
| A | | |
| SCALE: 1:4 | WEIGHT: | SHEET 8 OF 8 |