

ITEM NO.	PART NUMBER	DESCRIPTION	QTY.	CUT
1	B40618L-42"-AB-A-MV-30K-HEAD BASE TOP	18 GAUGE	1	
2	B40618L-42"-AB-A-MV-30K-8X8 BOLLARD BODY 1	18 GAUGE	2	
3	B40618L-42"-AB-A-MV-30K-8X8 BOLLARD BODY 2	18 GAUGE	2	
4	B40618L-42"-AB-A-MV-30K-BOTTOM RIBS	18 GAUGE	4	
5	B40618L-42"-AB-A-MV-30K-INSIDE BODY PLATE	18 GAUGE	1	
6	B40618L-42"-AB-A-MV-30K-HEAD TRIM BASE	18 GAUGE	1	
7	B40618L-42"-AB-A-MV-30K-HEAD BASE FRAME	18 GAUGE	2	
8	B40618L-42"-AB-A-MV-30K-TOP CAP TRIM 1	22 GAUGE	1	
9	B40618L-42"-AB-A-MV-30K-TOP CAP TRIM 2	22 GAUGE	1	
10	B40618L-42"-AB-A-MV-30K-LED MOUNTING PLATE	22 GAUGE	1	
11	B40618L-42"-AB-A-MV-30K-DRIVER BRACKET	22 GAUGE	1	
12	B40618L-42"-AB-A-MV-30K-TUBE BRACKET	22 GAUGE	1	
13	B40618L-42"-AB-A-MV-30K-FIREPLATE	ALUMINUM 0.125" PLATE	1	
14	B40618L-42"-AB-A-MV-30K-SQUARE TUBE	TUBE	1	
15	B40618L-42"-AB-A-MV-30K-ACRYLIC	ACRYLIC	4	
16	Espen VEL19070MVH-1	DRIVER	1	
17	Alttailed_PN1011_RevB	LED	4	

UNLESS OTHERWISE SPECIFIED:

DIMENSIONS ARE IN INCHES  
 TOLERANCES:  
 FRACTIONAL ± .003  
 ANGULAR: MACH ± .01 BEND ±  
 TWO PLACE DECIMAL ±  
 THREE PLACE DECIMAL ± .001

INTERPRET GEOMETRIC  
 TOLERANCING PER:

MATERIAL

FINISH

ALL BEND RADIUS .030"

APPLICATION

DO NOT SCALE DRAWING

	NAME	DATE
DRAWN		
CHECKED		
ENG APPR.		
MFG APPR.		
Q.A.		
COMMENTS:		

TITLE:

B40618L-42"-AB-A-MV-30K

SIZE	DWG. NO.	REV
<b>A</b>	TICKET 24708	

SCALE: 1:12 WEIGHT: SHEET 1 OF 13



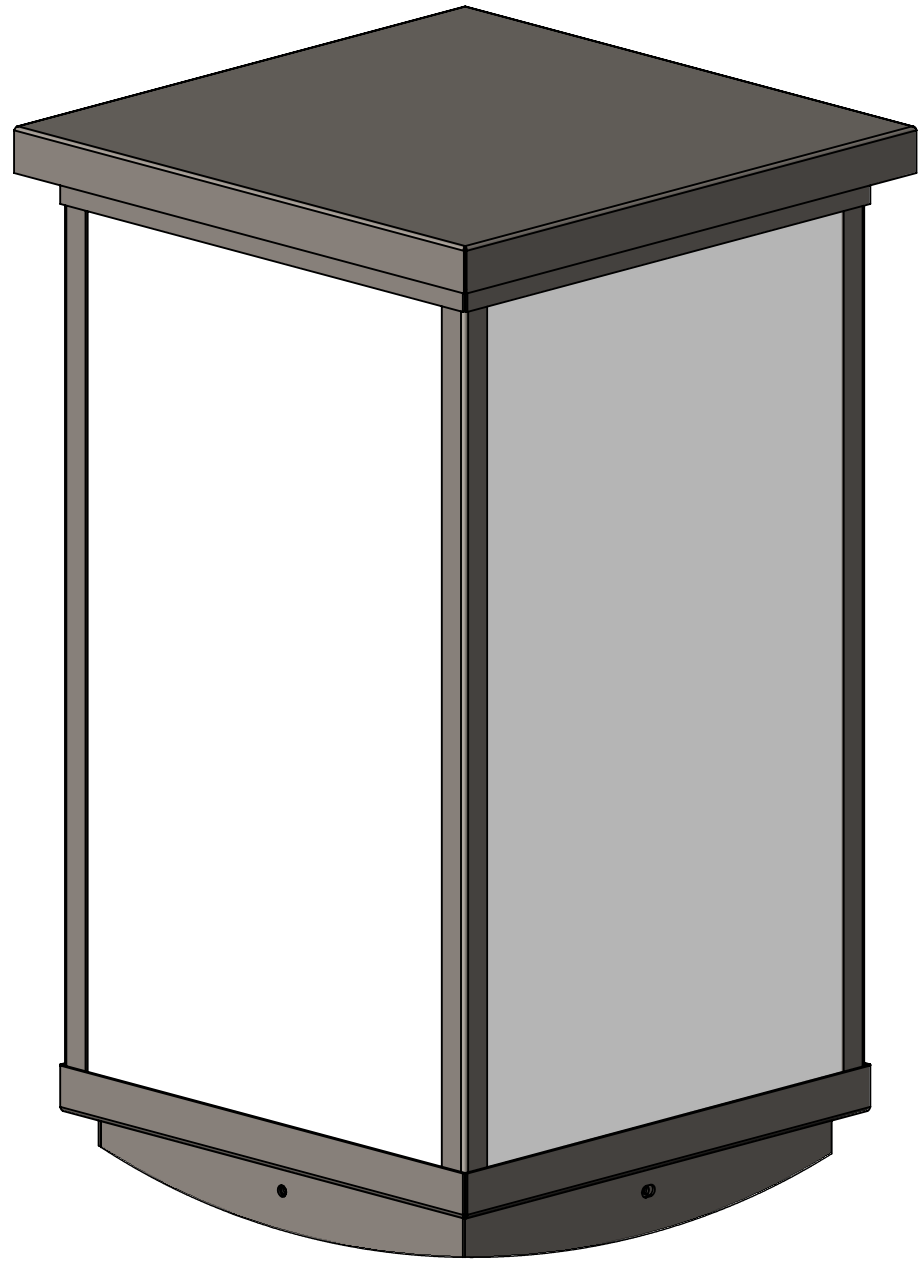
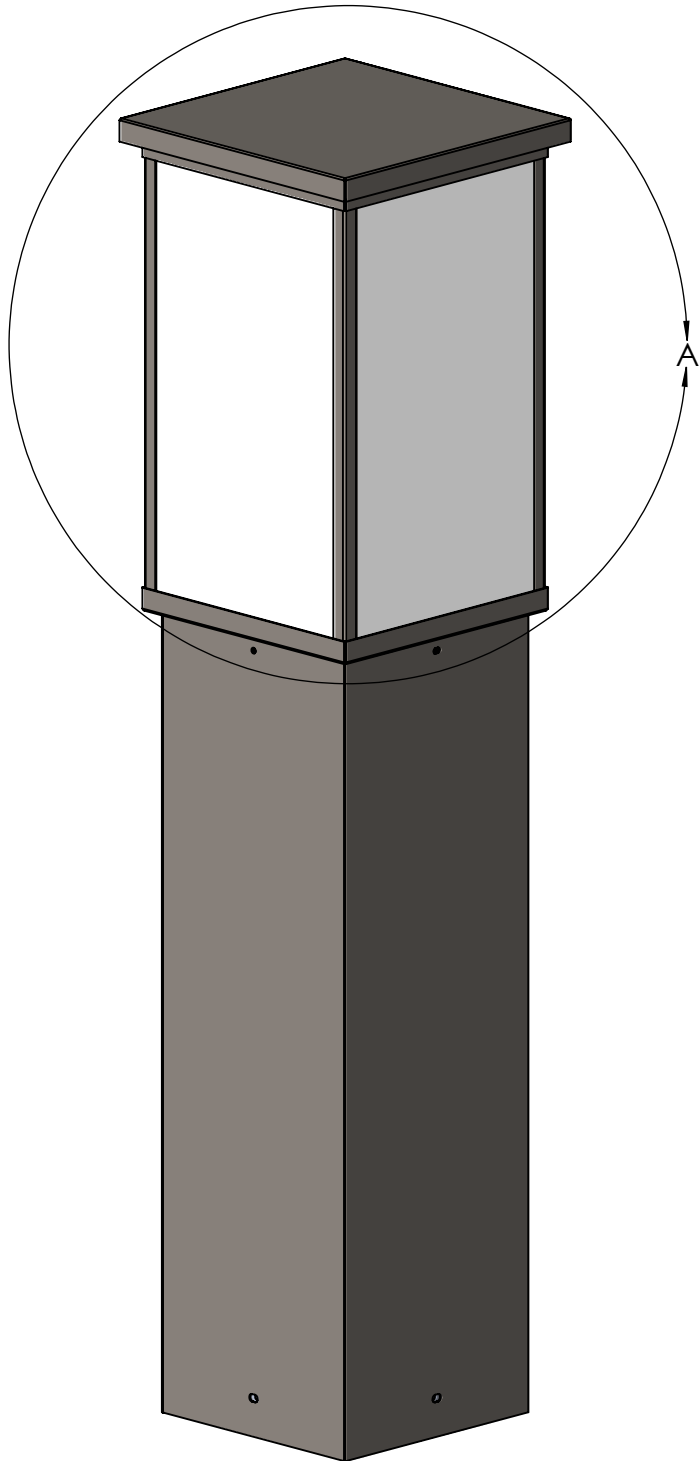

DETAIL A  
SCALE 1 : 3

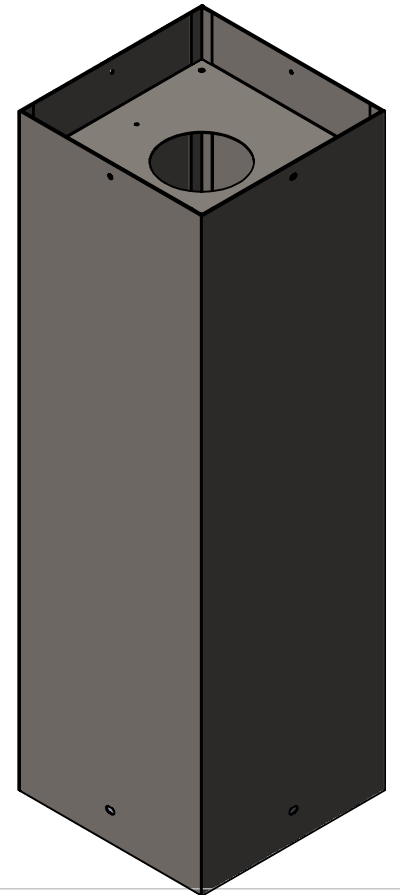
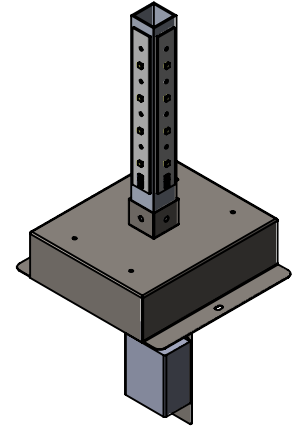
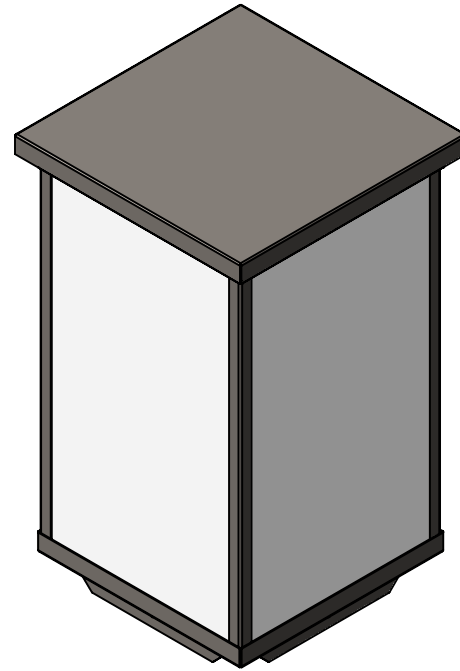
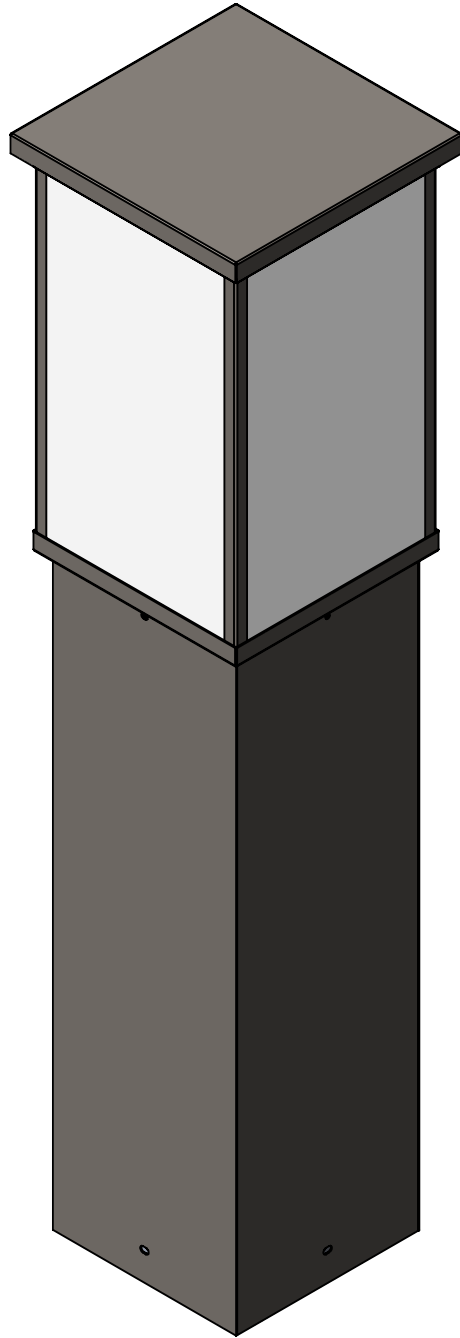
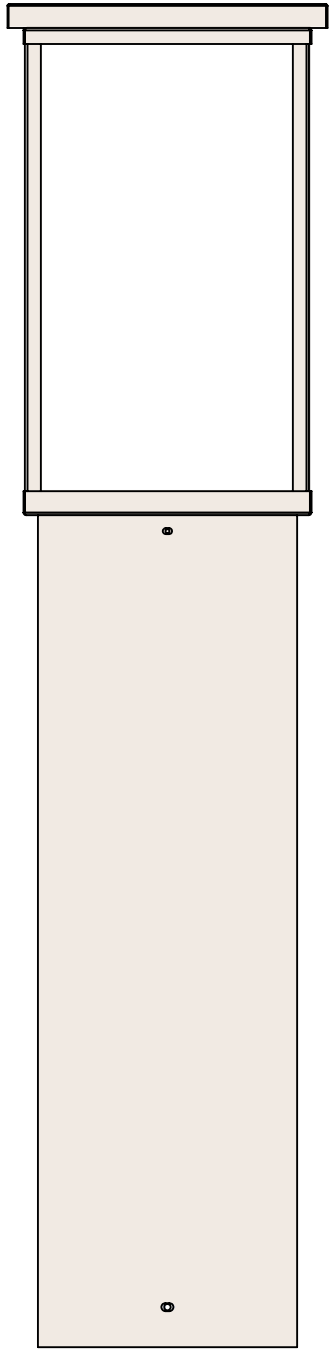

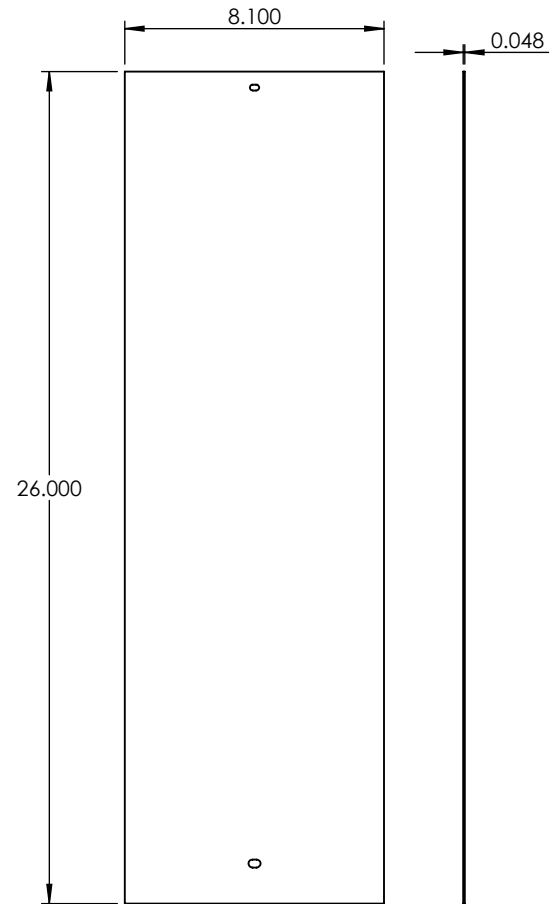
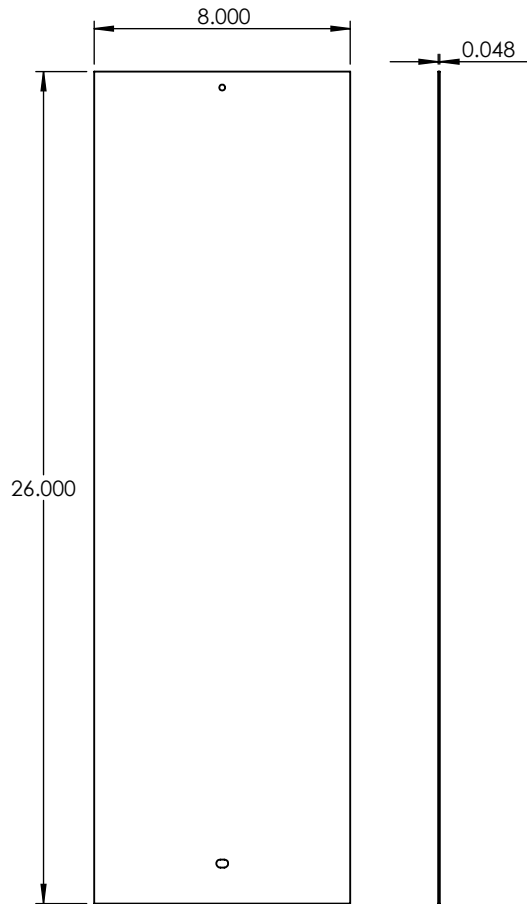

**PROPRIETARY AND CONFIDENTIAL**  
 THE INFORMATION CONTAINED IN THIS DRAWING IS THE SOLE PROPERTY OF <INSERT COMPANY NAME HERE>. ANY REPRODUCTION IN PART OR AS A WHOLE WITHOUT THE WRITTEN PERMISSION OF <INSERT COMPANY NAME HERE> IS PROHIBITED.

		UNLESS OTHERWISE SPECIFIED:		NAME	DATE	<b>18 GAUGE</b>		
		DIMENSIONS ARE IN INCHES TOLERANCES: FRACTIONAL ± ANGULAR: MACH ± BEND ± TWO PLACE DECIMAL ± THREE PLACE DECIMAL ±	DRAWN					<b>TITLE:</b>  B40618L-42"-AB-A-MV-30K
		INTERPRET GEOMETRIC TOLERANCING PER:	CHECKED			<b>SIZE</b> <b>A</b>	DWG. NO.	
		MATERIAL	ENG APPR.					SCALE: 1:6 WEIGHT: SHEET 4 OF 13
		FINISH	MFG APPR.			COMMENTS:		
NEXT ASSY	USED ON		Q.A.					DO NOT SCALE DRAWING
APPLICATION			COMMENTS:			DO NOT SCALE DRAWING		

5

4

3

2

1

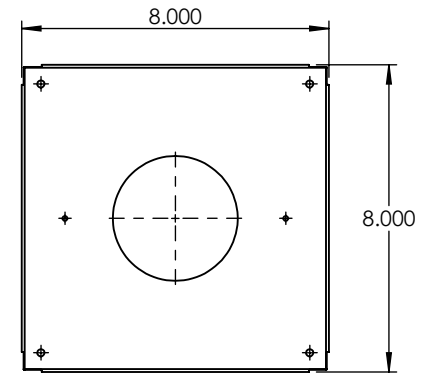
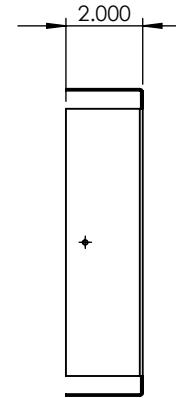
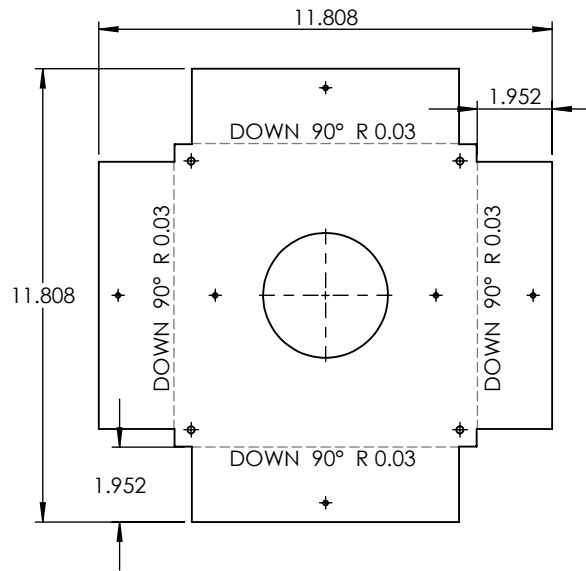
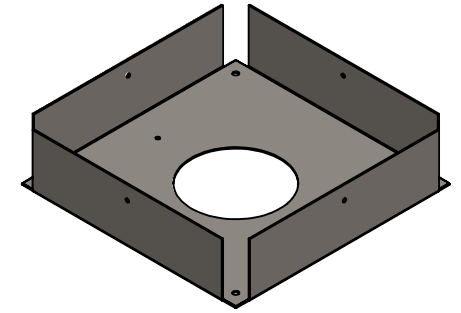
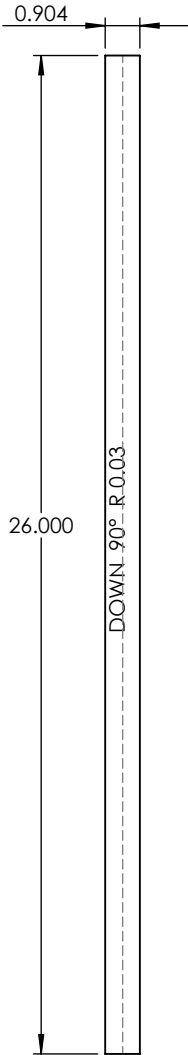
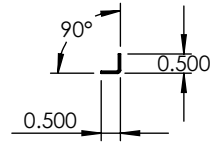

**PROPRIETARY AND CONFIDENTIAL**  
 THE INFORMATION CONTAINED IN THIS DRAWING IS THE SOLE PROPERTY OF <INSERT COMPANY NAME HERE>. ANY REPRODUCTION IN PART OR AS A WHOLE WITHOUT THE WRITTEN PERMISSION OF <INSERT COMPANY NAME HERE> IS PROHIBITED.

		UNLESS OTHERWISE SPECIFIED:		NAME	DATE
		DIMENSIONS ARE IN INCHES	DRAWN		
		TOLERANCES:	CHECKED		
		FRACTIONAL ±	ENG APPR.		
		ANGULAR: MACH ± BEND ±	MFG APPR.		
		TWO PLACE DECIMAL ±	Q.A.		
		THREE PLACE DECIMAL ±	COMMENTS:		
		INTERPRET GEOMETRIC TOLERANCING PER:			
		MATERIAL			
NEXT ASSY	USED ON	FINISH			
APPLICATION		DO NOT SCALE DRAWING			

18 GAUGE		
TITLE:		
B40618L-42"-AB-A-MV-30K		
SIZE	DWG. NO.	REV
<b>A</b>		
SCALE: 1:5	WEIGHT:	SHEET 5 OF 13

5

4

3

2

1

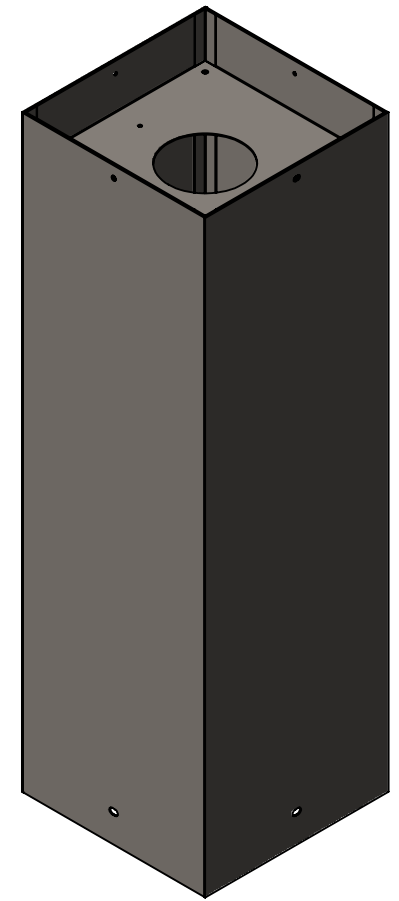
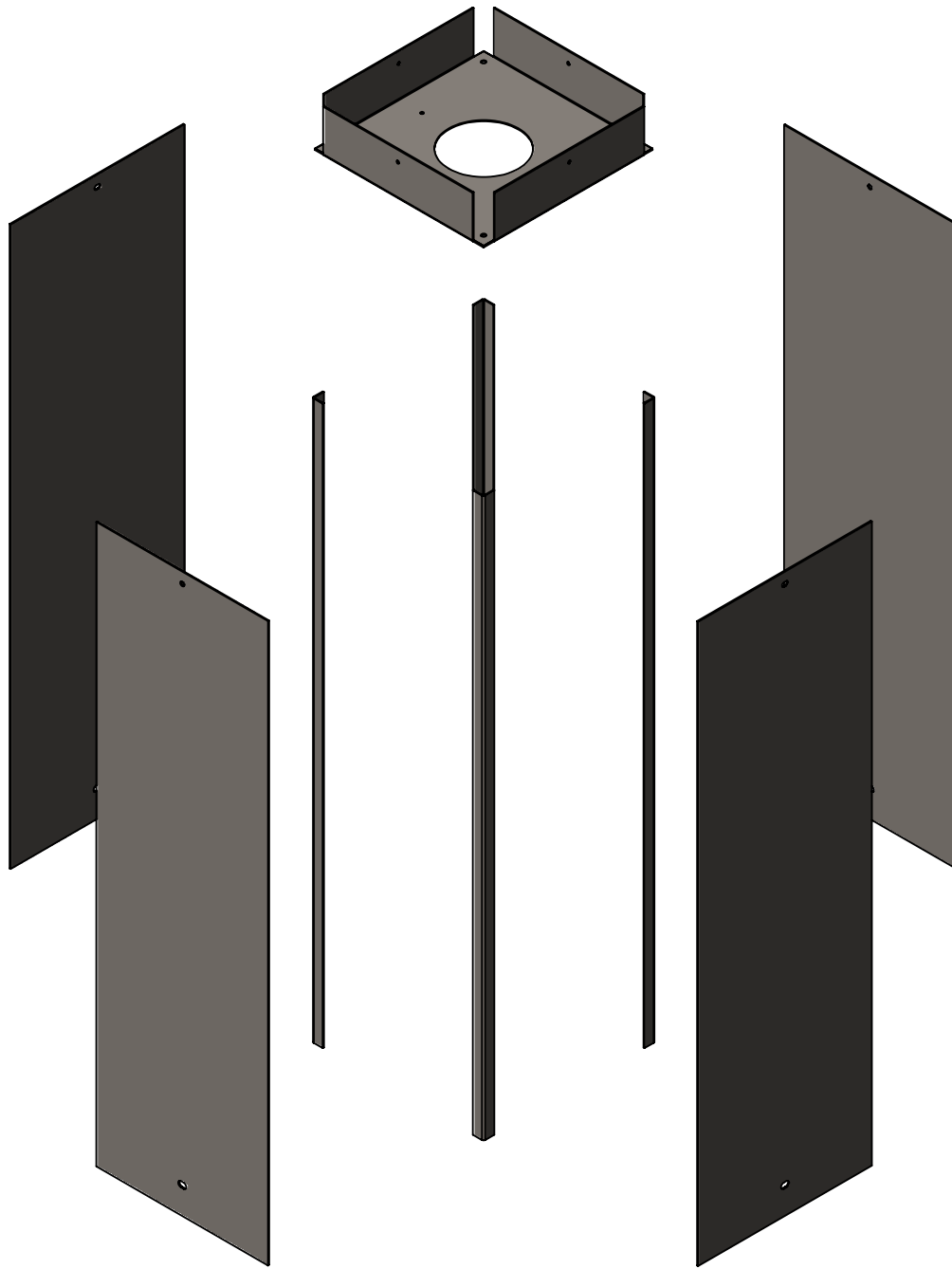

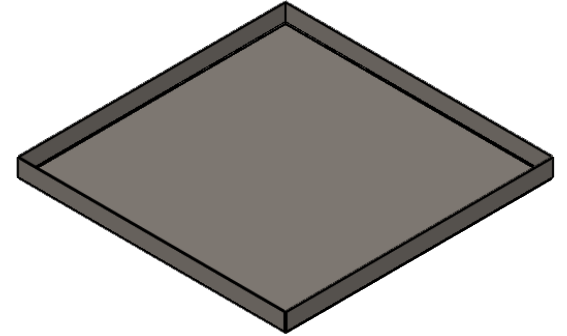
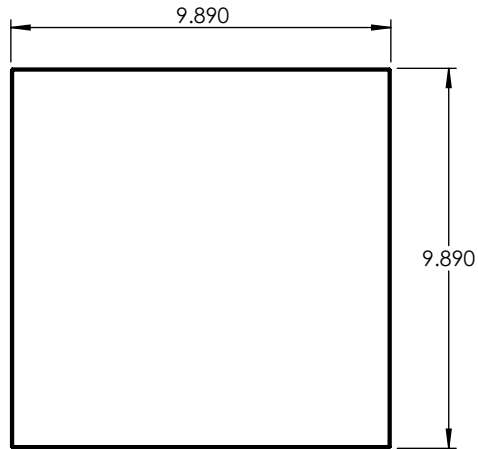
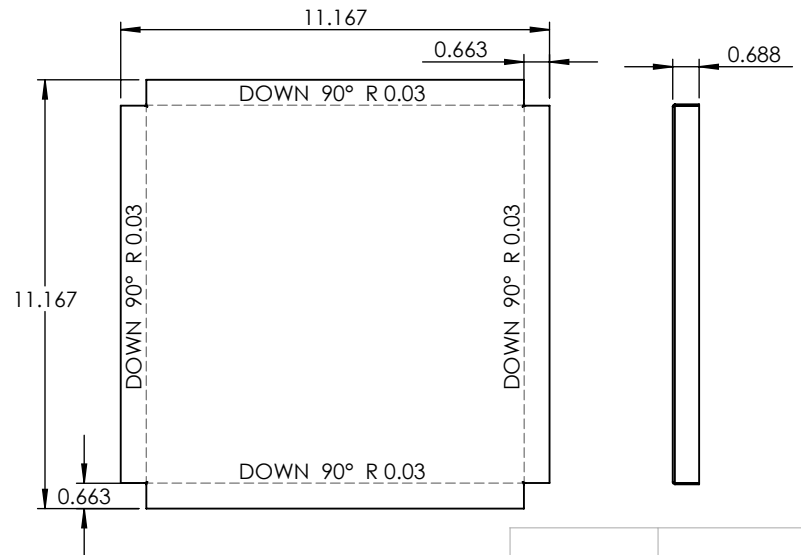
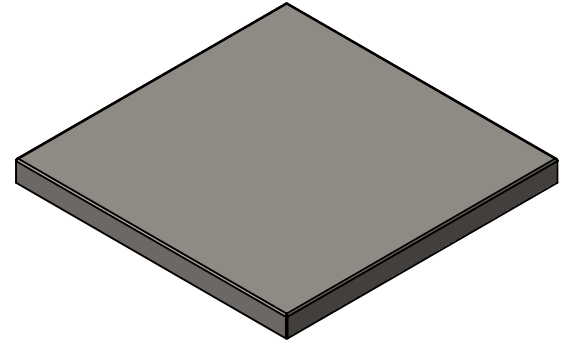
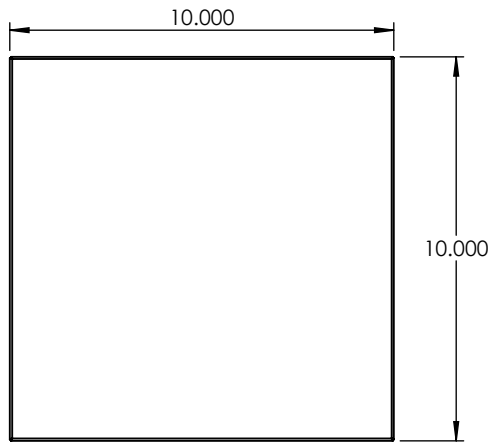
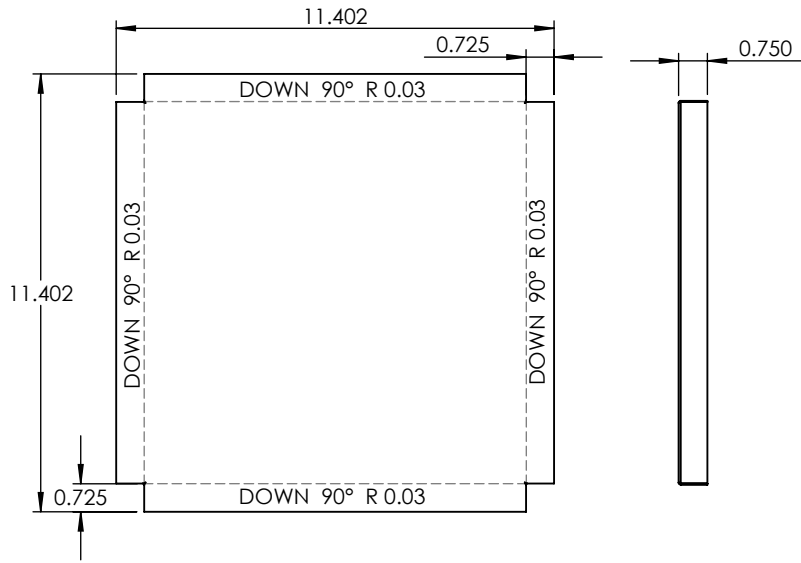

**PROPRIETARY AND CONFIDENTIAL**  
 THE INFORMATION CONTAINED IN THIS DRAWING IS THE SOLE PROPERTY OF <INSERT COMPANY NAME HERE>. ANY REPRODUCTION IN PART OR AS A WHOLE WITHOUT THE WRITTEN PERMISSION OF <INSERT COMPANY NAME HERE> IS PROHIBITED.

		UNLESS OTHERWISE SPECIFIED:		NAME	DATE
		DIMENSIONS ARE IN INCHES	DRAWN		
		TOLERANCES:	CHECKED		
		FRACTIONAL ±	ENG APPR.		
		ANGULAR: MACH ± BEND ±	MFG APPR.		
		TWO PLACE DECIMAL ±	Q.A.		
		THREE PLACE DECIMAL ±	COMMENTS:		
		INTERPRET GEOMETRIC TOLERANCING PER:			
		MATERIAL			
	NEXT ASSY	USED ON			
		FINISH			
	APPLICATION	DO NOT SCALE DRAWING			

<b>22 GAUGE</b>		
TITLE:		
<b>B40618L-42"-AB-A-MV-30K</b>		
SIZE	DWG. NO.	REV
<b>A</b>		
SCALE: 1:5	WEIGHT:	SHEET 7 OF 13

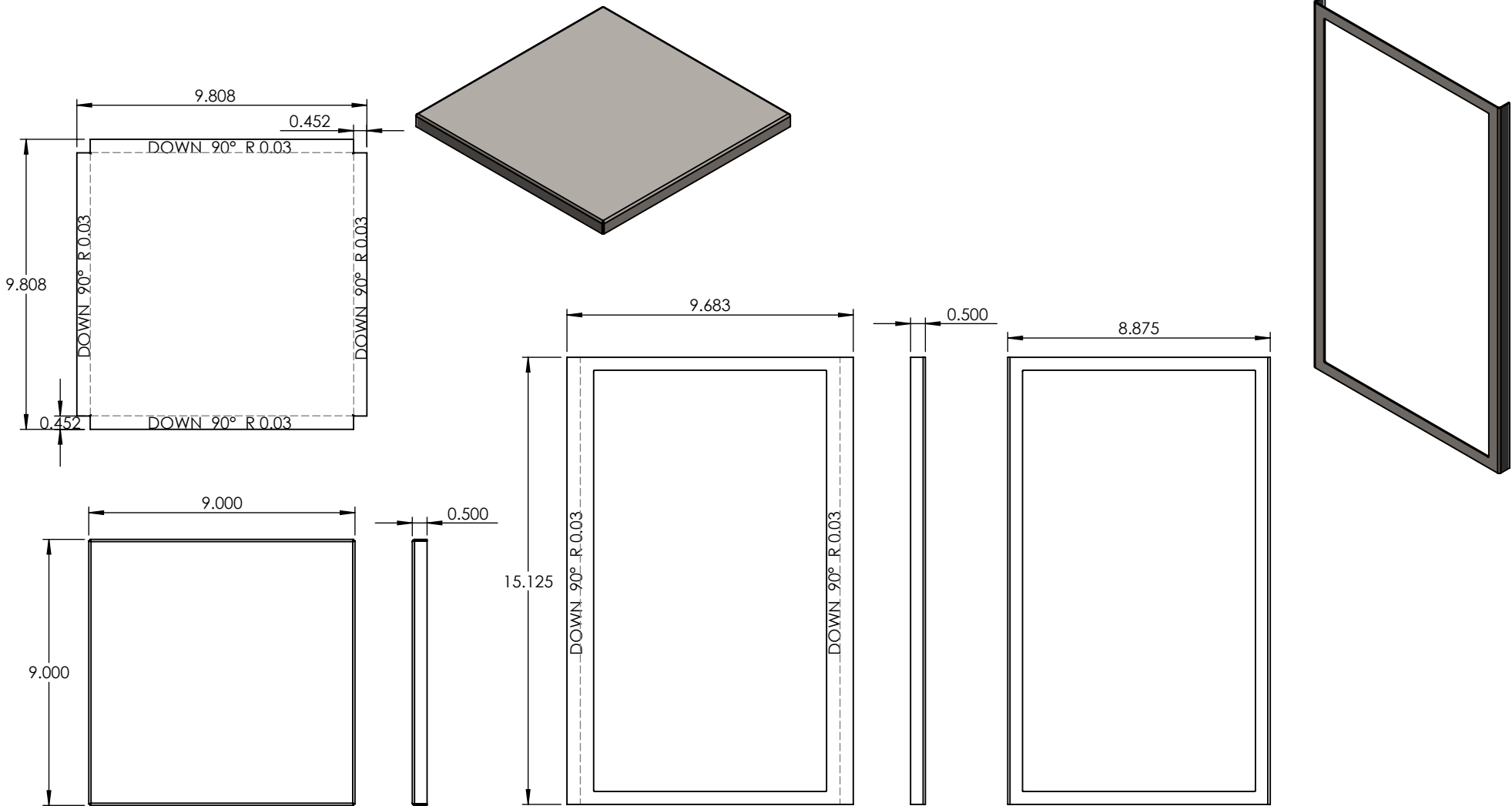

**PROPRIETARY AND CONFIDENTIAL**  
 THE INFORMATION CONTAINED IN THIS DRAWING IS THE SOLE PROPERTY OF <INSERT COMPANY NAME HERE>. ANY REPRODUCTION IN PART OR AS A WHOLE WITHOUT THE WRITTEN PERMISSION OF <INSERT COMPANY NAME HERE> IS PROHIBITED.

		UNLESS OTHERWISE SPECIFIED:	NAME	DATE
		DIMENSIONS ARE IN INCHES	DRAWN	
		TOLERANCES:	CHECKED	
		FRACTIONAL ±	ENG APPR.	
		ANGULAR: MACH ± BEND ±	MFG APPR.	
		TWO PLACE DECIMAL ±	Q.A.	
		THREE PLACE DECIMAL ±	COMMENTS:	
		INTERPRET GEOMETRIC TOLERANCING PER:		
		MATERIAL		
	NEXT ASSY	USED ON		
		FINISH		
	APPLICATION	DO NOT SCALE DRAWING		

18 GAUGE		
TITLE:		
B40618L-42"-AB-A-MV-30K		
SIZE	DWG. NO.	REV
<b>A</b>		
SCALE: 1:6	WEIGHT:	SHEET 8 OF 13



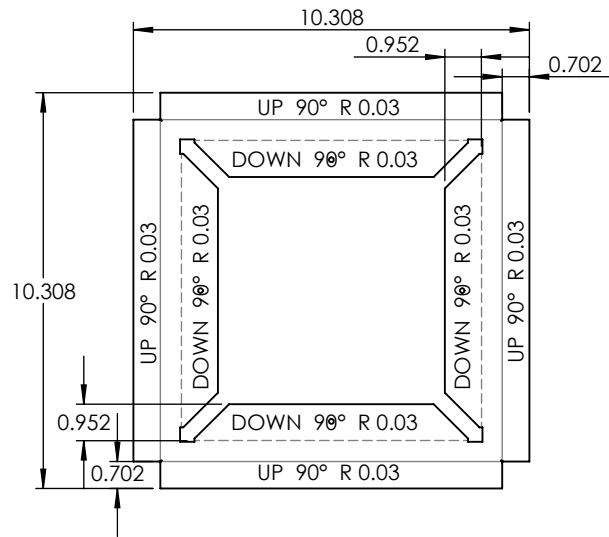
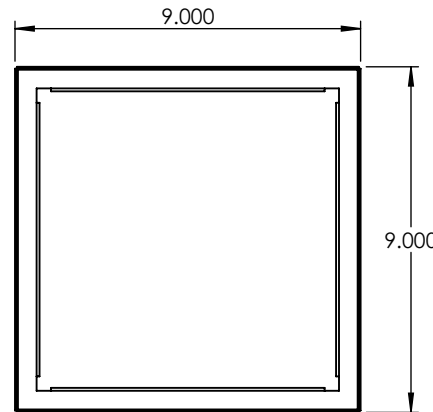
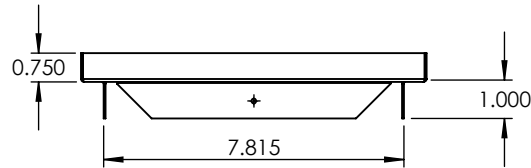
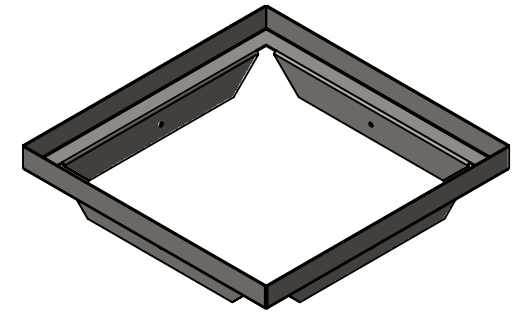

**PROPRIETARY AND CONFIDENTIAL**  
 THE INFORMATION CONTAINED IN THIS DRAWING IS THE SOLE PROPERTY OF <INSERT COMPANY NAME HERE>. ANY REPRODUCTION IN PART OR AS A WHOLE WITHOUT THE WRITTEN PERMISSION OF <INSERT COMPANY NAME HERE> IS PROHIBITED.

		UNLESS OTHERWISE SPECIFIED:	NAME	DATE	18 GAUGE	
		DIMENSIONS ARE IN INCHES TOLERANCES: FRACTIONAL ± ANGULAR: MACH ± BEND ± TWO PLACE DECIMAL ± THREE PLACE DECIMAL ±	DRAWN			
		INTERPRET GEOMETRIC TOLERANCING PER:	CHECKED		SIZE DWG. NO. REV	
		MATERIAL	ENG APPR.			
		FINISH	MFG APPR.			
NEXT ASSY	USED ON		Q.A.			
APPLICATION		DO NOT SCALE DRAWING	COMMENTS:			

5

4

3

2

1

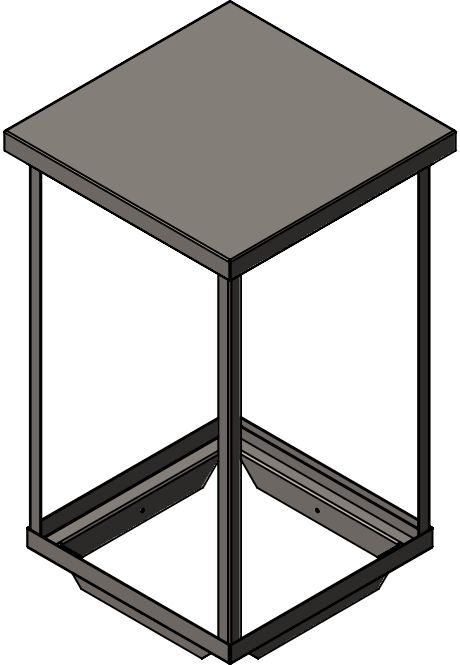
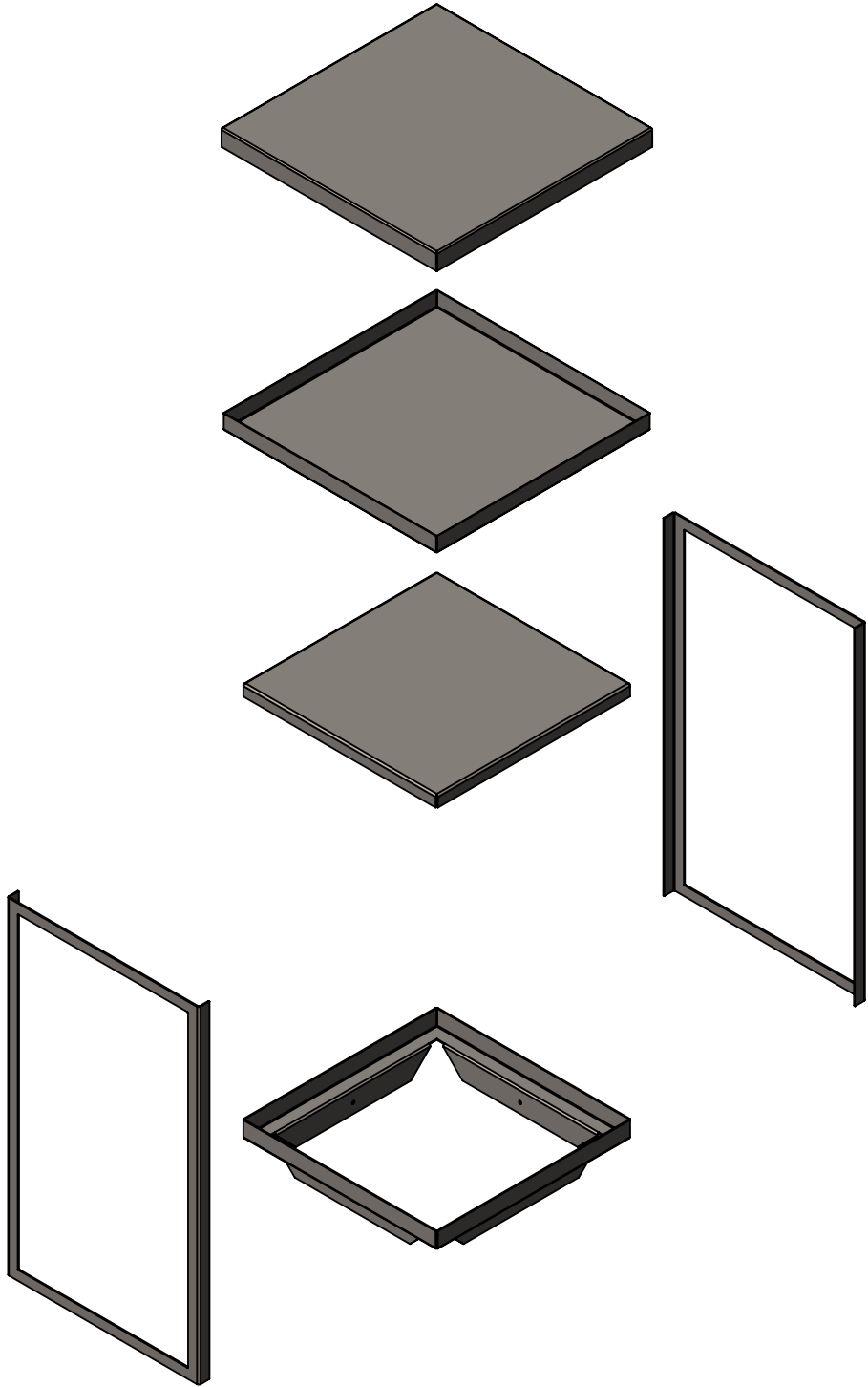

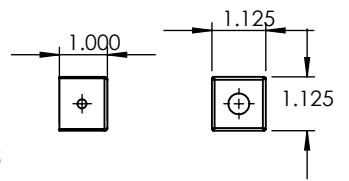
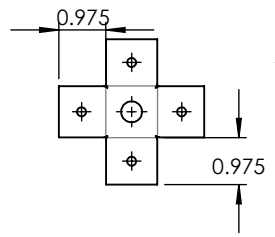
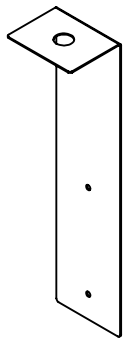
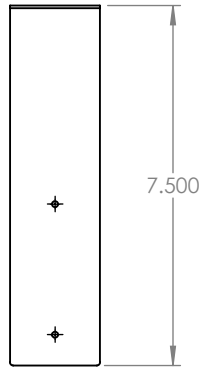
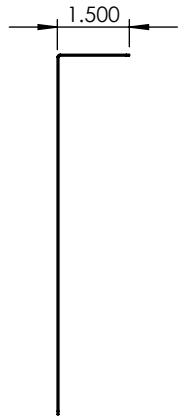
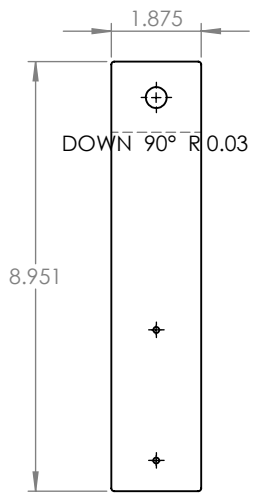
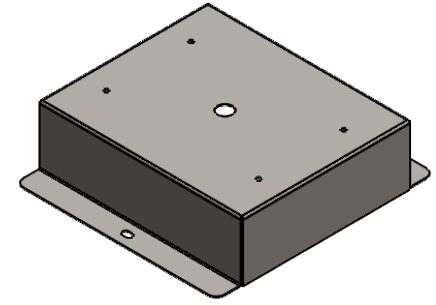
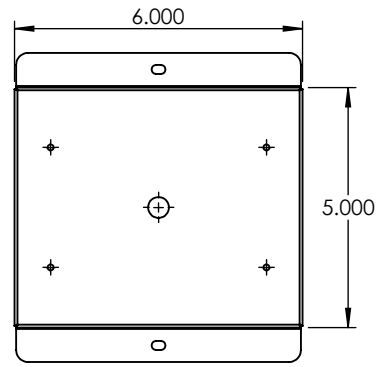
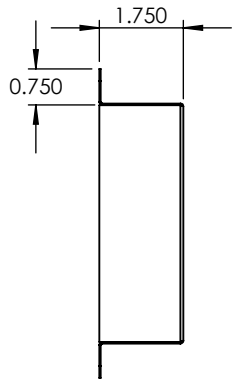
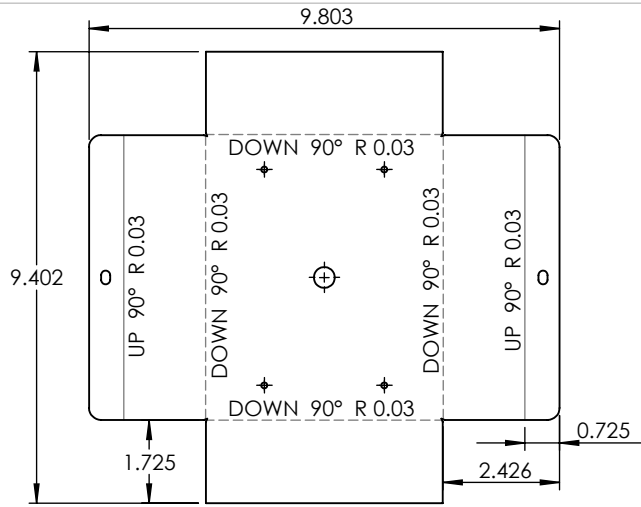

		UNLESS OTHERWISE SPECIFIED:	NAME	DATE
		DIMENSIONS ARE IN INCHES	DRAWN	
		TOLERANCES:	CHECKED	
		FRACTIONAL ±	ENG APPR.	
		ANGULAR: MACH ± BEND ±	MFG APPR.	
		TWO PLACE DECIMAL ±	Q.A.	
		THREE PLACE DECIMAL ±	COMMENTS:	
		INTERPRET GEOMETRIC TOLERANCING PER:		
		MATERIAL		
NEXT ASSY	USED ON	FINISH		
APPLICATION		DO NOT SCALE DRAWING		

18 GAUGE		
TITLE:		
B40618L-42"-AB-A-MV-30K		
SIZE	DWG. NO.	REV
<b>A</b>		
SCALE: 1:4	WEIGHT:	SHEET 11 OF 13

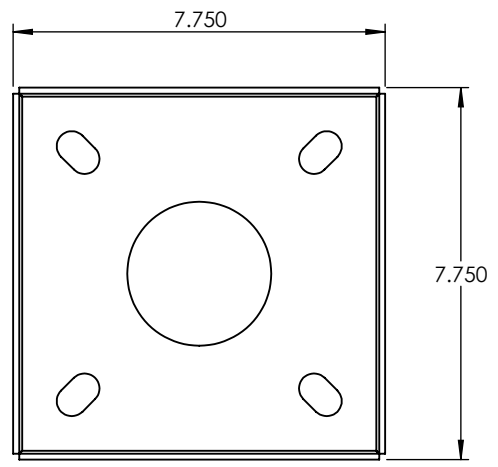
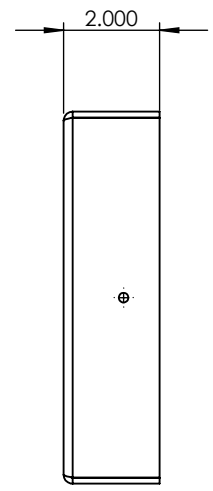
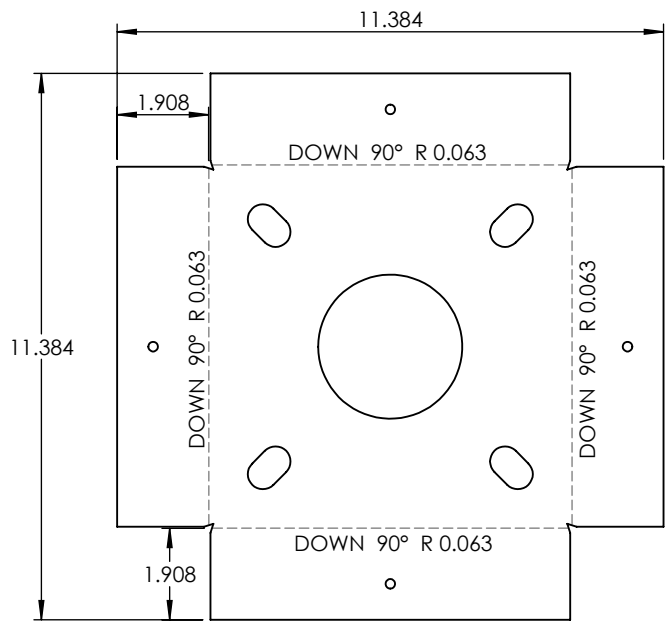
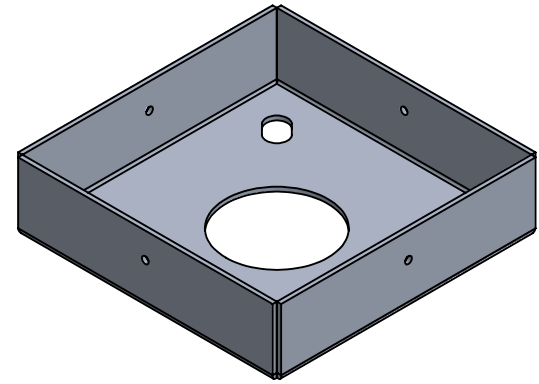

**PROPRIETARY AND CONFIDENTIAL**  
 THE INFORMATION CONTAINED IN THIS DRAWING IS THE SOLE PROPERTY OF <INSERT COMPANY NAME HERE>. ANY REPRODUCTION IN PART OR AS A WHOLE WITHOUT THE WRITTEN PERMISSION OF <INSERT COMPANY NAME HERE> IS PROHIBITED.

		UNLESS OTHERWISE SPECIFIED:		NAME	DATE
		DIMENSIONS ARE IN INCHES	DRAWN		
		TOLERANCES:	CHECKED		
		FRACTIONAL ±	ENG APPR.		
		ANGULAR: MACH ± BEND ±	MFG APPR.		
		TWO PLACE DECIMAL ±	Q.A.		
		THREE PLACE DECIMAL ±	COMMENTS:		
		INTERPRET GEOMETRIC TOLERANCING PER:			
		MATERIAL			
	NEXT ASSY	USED ON			
		FINISH			
	APPLICATION	DO NOT SCALE DRAWING			

ALUMINUM 0.125" PLATE		
TITLE:		
B40618L-42"-AB-A-MV-30K		
SIZE	DWG. NO.	REV
<b>A</b>		
SCALE: 1:4	WEIGHT:	SHEET 12 OF 13

5

4

3

2

1

