

ITEM NO.	PART NUMBER	DESCRIPTION	QTY.	CUT
1	LIN-SQ48"-24W-MN-WF-AEC-DIM-WET-41K-FRAME	22 GAUGE	1	
2	LIN-SQ48"-24W-MN-WF-AEC-DIM-WET-41K-FRAME TAB	22 GAUGE	4	
3	LIN-SQ48"-24W-MN-WF-AEC-DIM-WET-41K-BACKPLATE	22 GAUGE	1	
4	LIN-SQ48"-24W-MN-WF-AEC-DIM-WET-41K-FIREPLATE	22 GAUGE	1	
5	LIN-SQ48"-24W-MN-WF-AEC-DIM-WET-41K-LED SPACER	22 GAUGE	1	
6	LIN-SQ48"-24W-MN-WF-AEC-DIM-WET-41K-ACRYLIC	ACRYLIC	1	
7	KTLD-25-UV-700-VDIM-LA1	DRIVER	1	
8	AlfaILED PN105B-11-SS	LED	4	

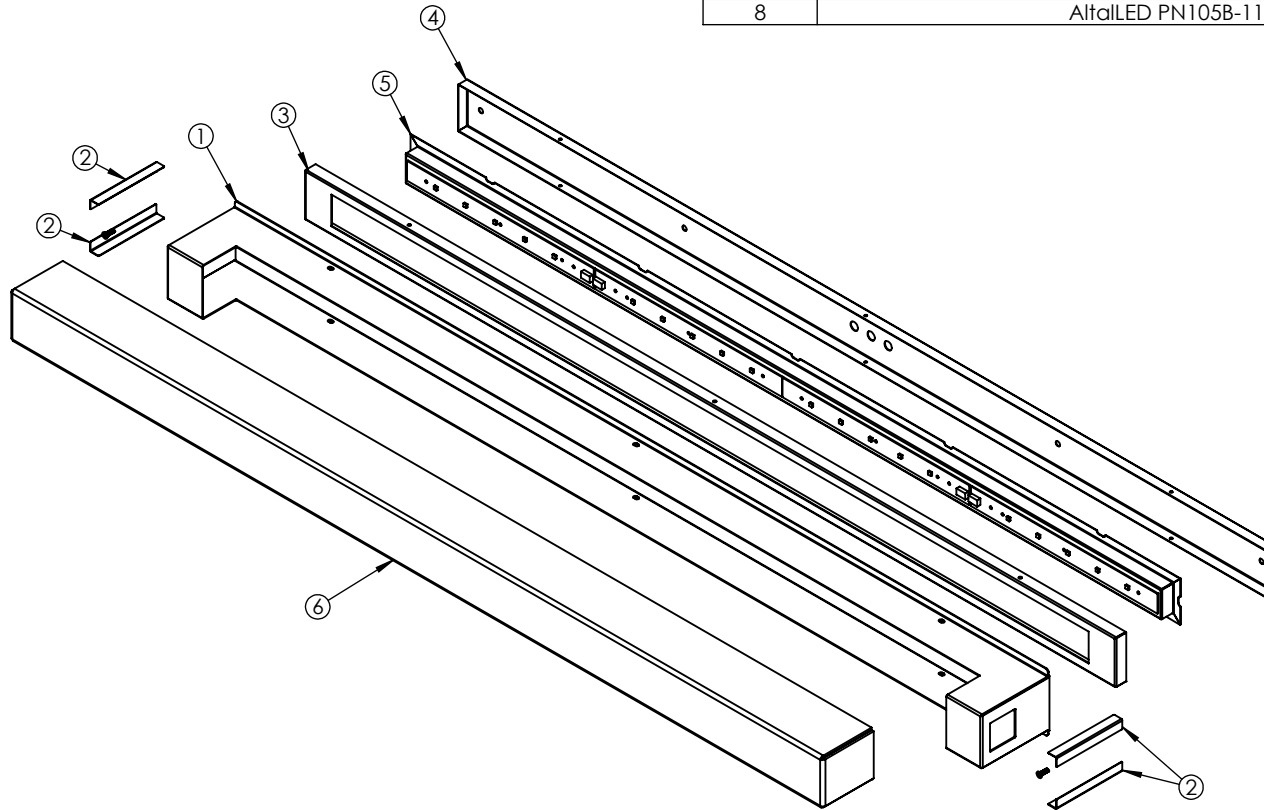

UNLESS OTHERWISE SPECIFIED:	NAME	DATE	TITLE:		
DIMENSIONS ARE IN INCHES	DRAWN		LIN-SQ48"-24W-MN-WF-AEC-DIM-WET-41K		
TOLERANCES:	CHECKED				
FRACTIONAL ± .003	ENG APPR.				
ANGULAR: MACH ± .01 BEND ±	MFG APPR.				
TWO PLACE DECIMAL ±	Q.A.		SIZE	DWG. NO.	REV
THREE PLACE DECIMAL ±.001	COMMENTS:		<b>A</b>	TICKET 24879	
INTERPRET GEOMETRIC TOLERANCING PER:			SCALE: 1:8	WEIGHT:	SHEET 1 OF 8
MATERIAL					
FINISH					



ALL BEND RADIUS .030"

APPLICATION

DO NOT SCALE DRAWING

5

4

3

2

1

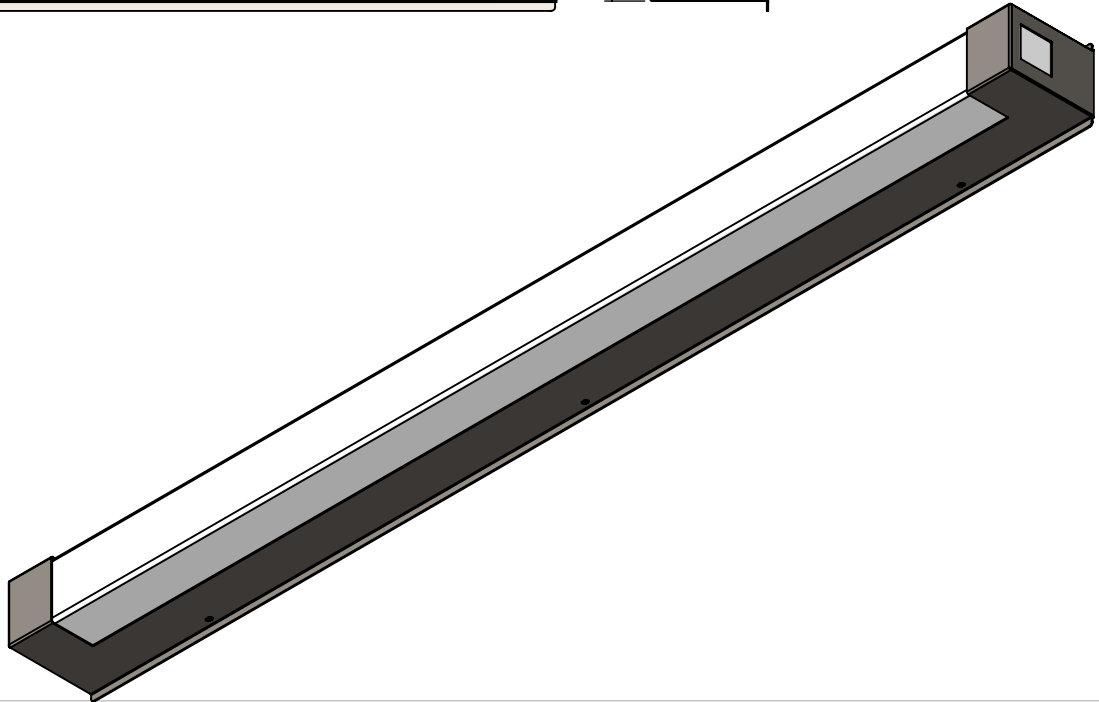
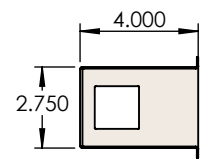
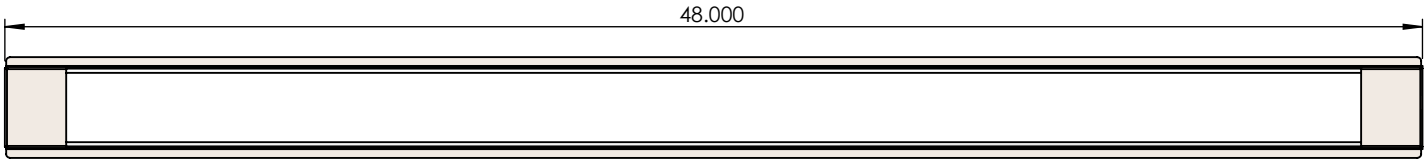
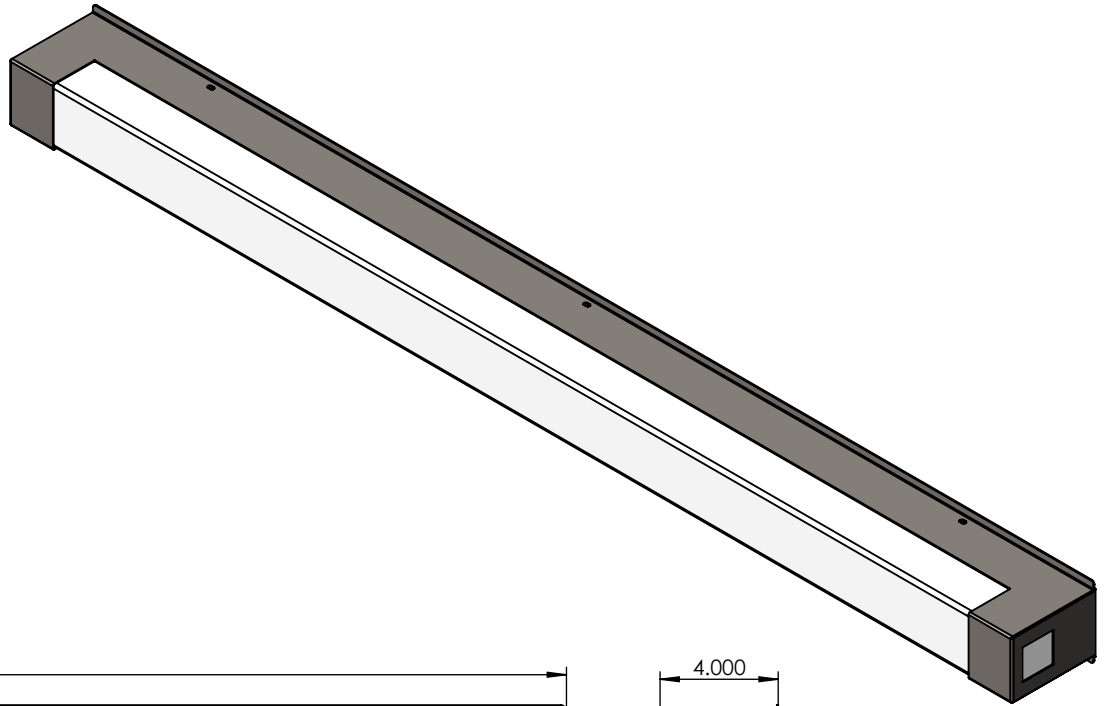

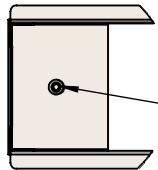
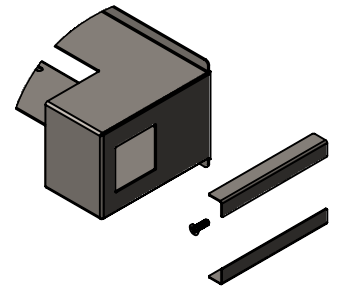
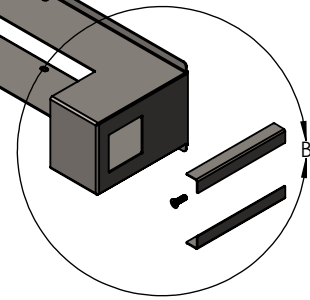
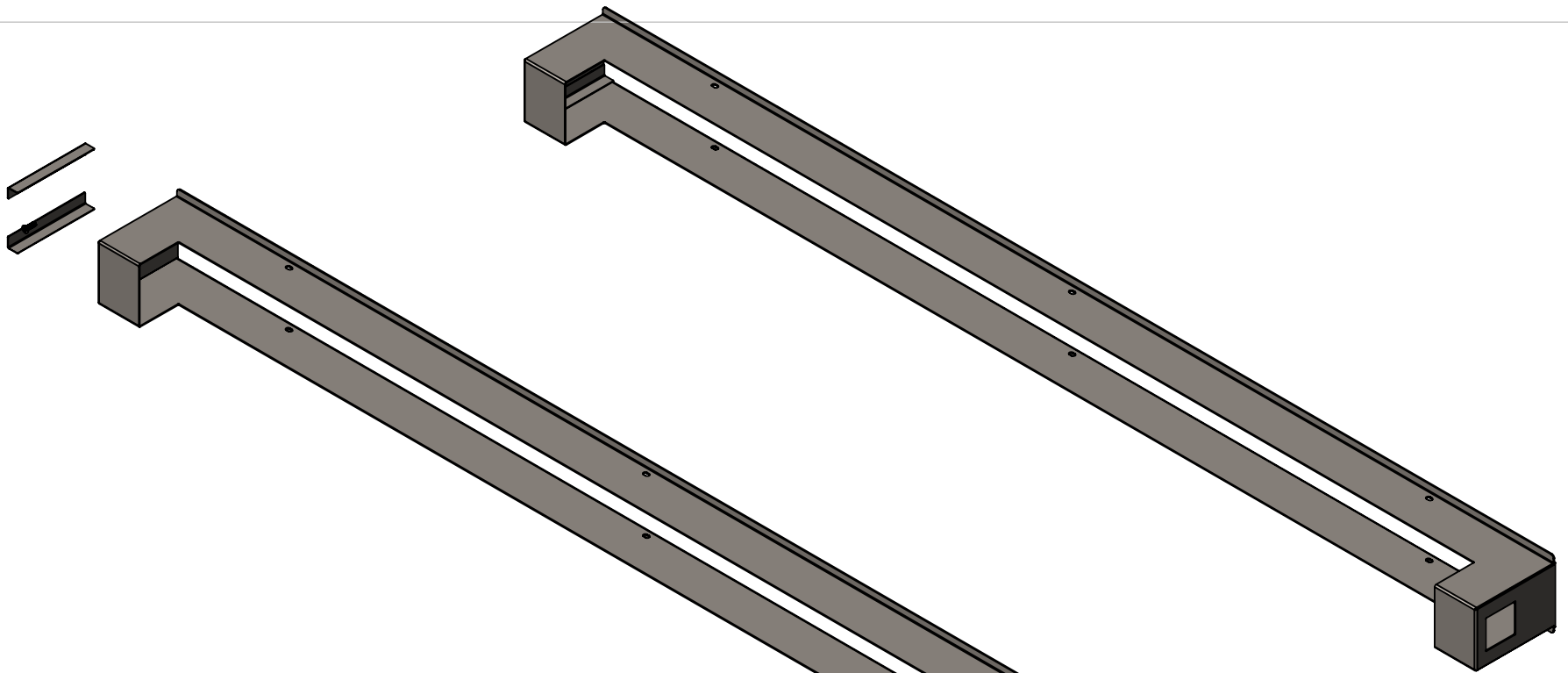

THREADED STUD WELDED TO FRAME END BACKSIDE,  
USED TO SECURE LENS TO INSIDE OF FRAME

DETAIL C  
SCALE 1 : 4

DETAIL B  
SCALE 1 : 5

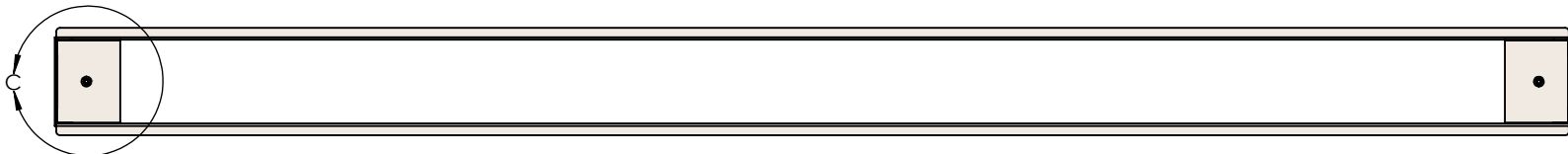



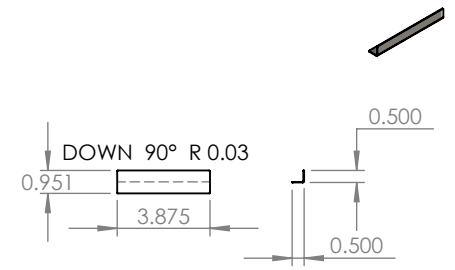
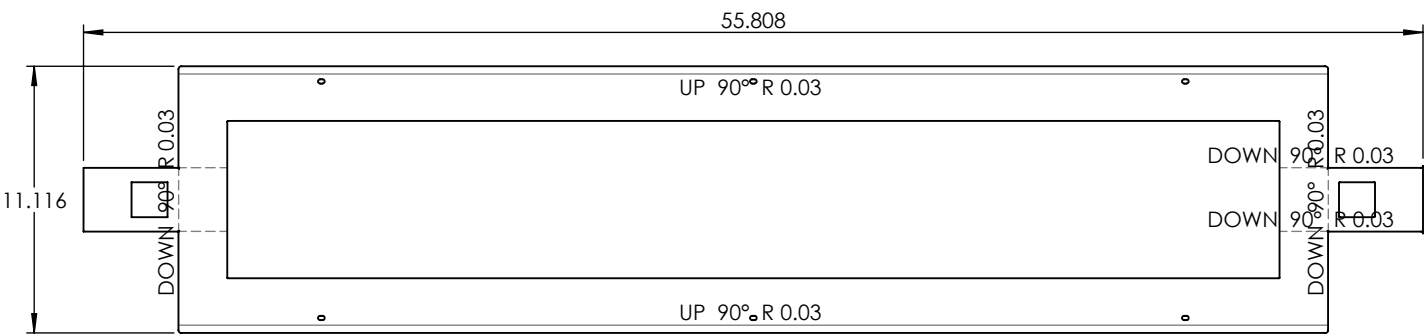
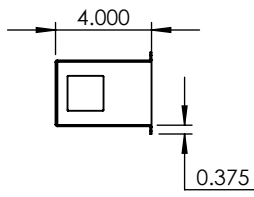
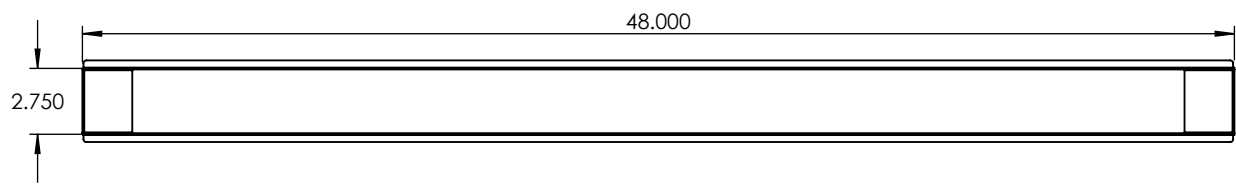
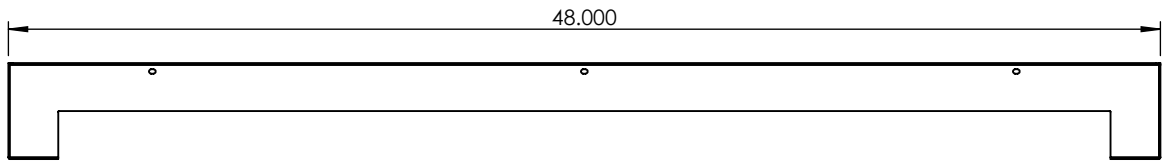
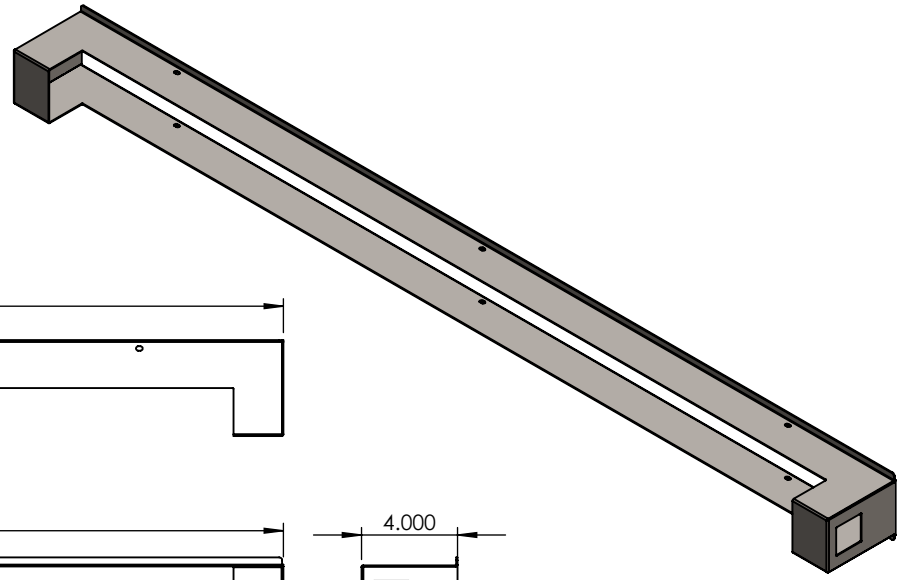

UNLESS OTHERWISE SPECIFIED:	NAME	DATE
DIMENSIONS ARE IN INCHES	DRAWN	
TOLERANCES:	CHECKED	
FRACTIONAL ±	ENG APPR.	
ANGULAR: MACH ± BEND ±	MFG APPR.	
TWO PLACE DECIMAL ±		
THREE PLACE DECIMAL ±		

22 GAUGE

TITLE:

LIN-SQ48"-24W-MN-WF-AEC-DIM-WET-41K

**PROPRIETARY AND CONFIDENTIAL**  
 THE INFORMATION CONTAINED IN THIS DRAWING IS THE SOLE PROPERTY OF <INSERT COMPANY NAME HERE>. ANY REPRODUCTION IN PART OR AS A WHOLE WITHOUT THE WRITTEN PERMISSION OF <INSERT COMPANY NAME HERE> IS PROHIBITED.

		INTERPRET GEOMETRIC TOLERANCING PER:
		MATERIAL
NEXT ASSY	USED ON	FINISH
APPLICATION		DO NOT SCALE DRAWING

Q.A.  
 COMMENTS:

SIZE	DWG. NO.	REV
<b>A</b>		
SCALE: 1:8	WEIGHT:	SHEET 5 OF 8

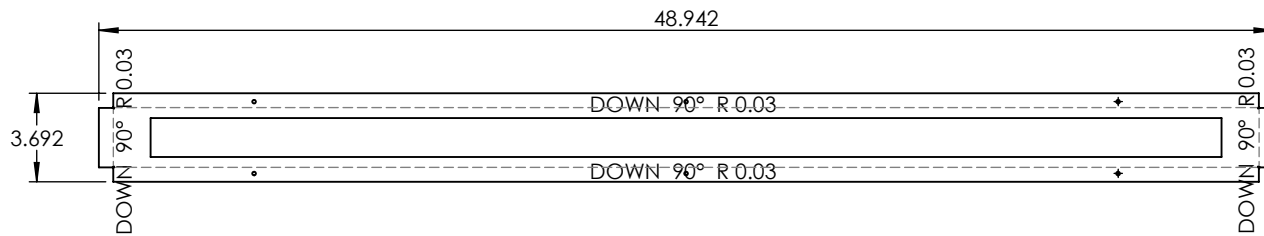
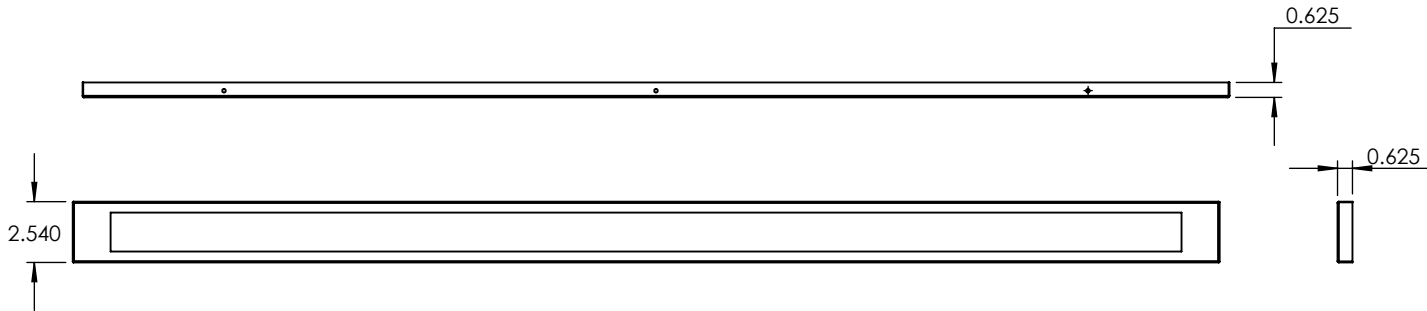
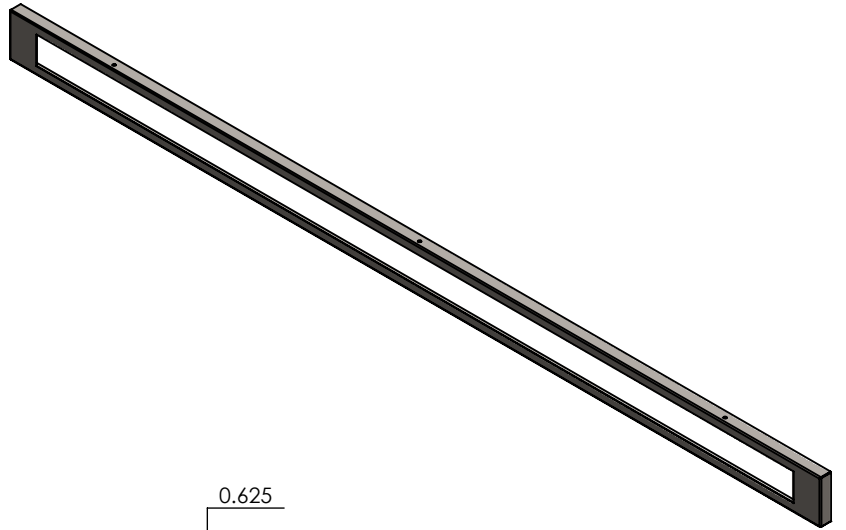

UNLESS OTHERWISE SPECIFIED:		NAME	DATE	22 GAUGE		
DIMENSIONS ARE IN INCHES TOLERANCES: FRACTIONAL ± ANGULAR: MACH ± BEND ± TWO PLACE DECIMAL ± THREE PLACE DECIMAL ±		DRAWN				TITLE:  LIN-SQ48"-24W-MN-WF-AEC-DIM-WET-41K
INTERPRET GEOMETRIC TOLERANCING PER:		CHECKED		SIZE	DWG. NO.	
MATERIAL		ENG APPR.		<b>A</b>		
FINISH		MFG APPR.				
APPLICATION		Q.A.				
DO NOT SCALE DRAWING		COMMENTS:				

**PROPRIETARY AND CONFIDENTIAL**  
THE INFORMATION CONTAINED IN THIS DRAWING IS THE SOLE PROPERTY OF <INSERT COMPANY NAME HERE>. ANY REPRODUCTION IN PART OR AS A WHOLE WITHOUT THE WRITTEN PERMISSION OF <INSERT COMPANY NAME HERE> IS PROHIBITED.

NEXT ASSY	USED ON
APPLICATION	

5

4

3

2

1

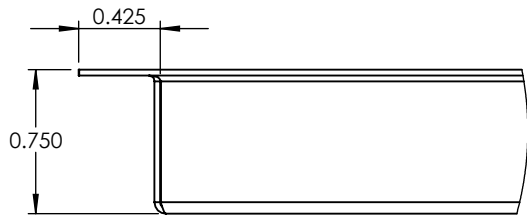

DETAIL A  
SCALE 1 : 1

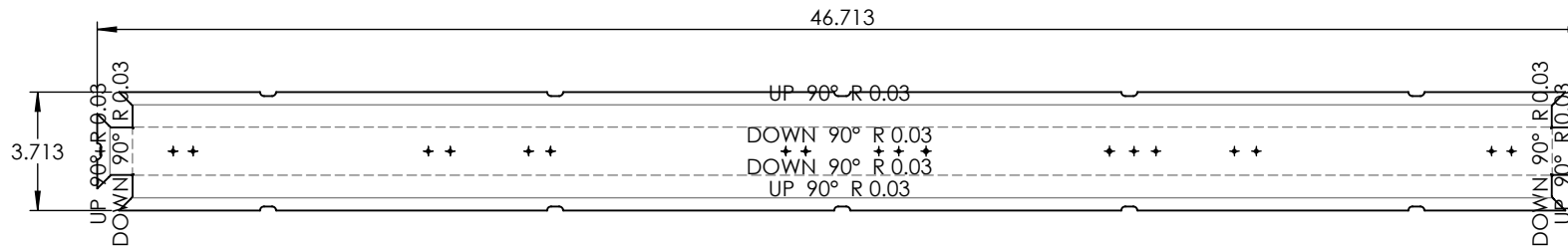
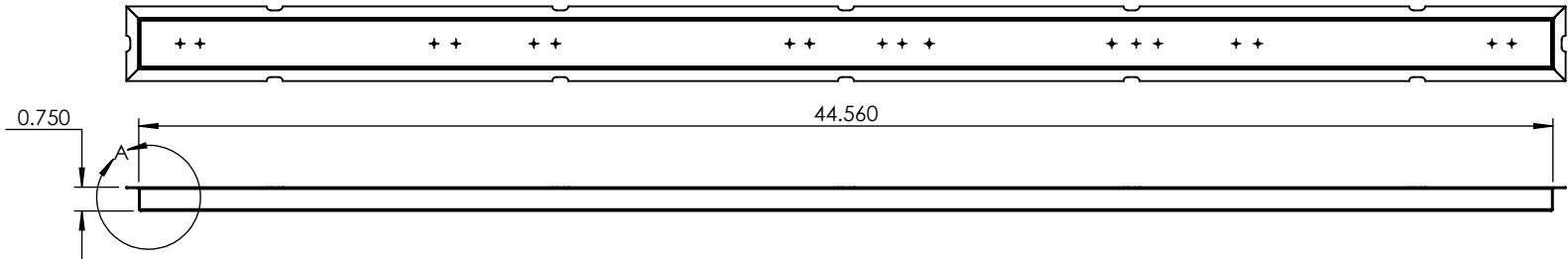
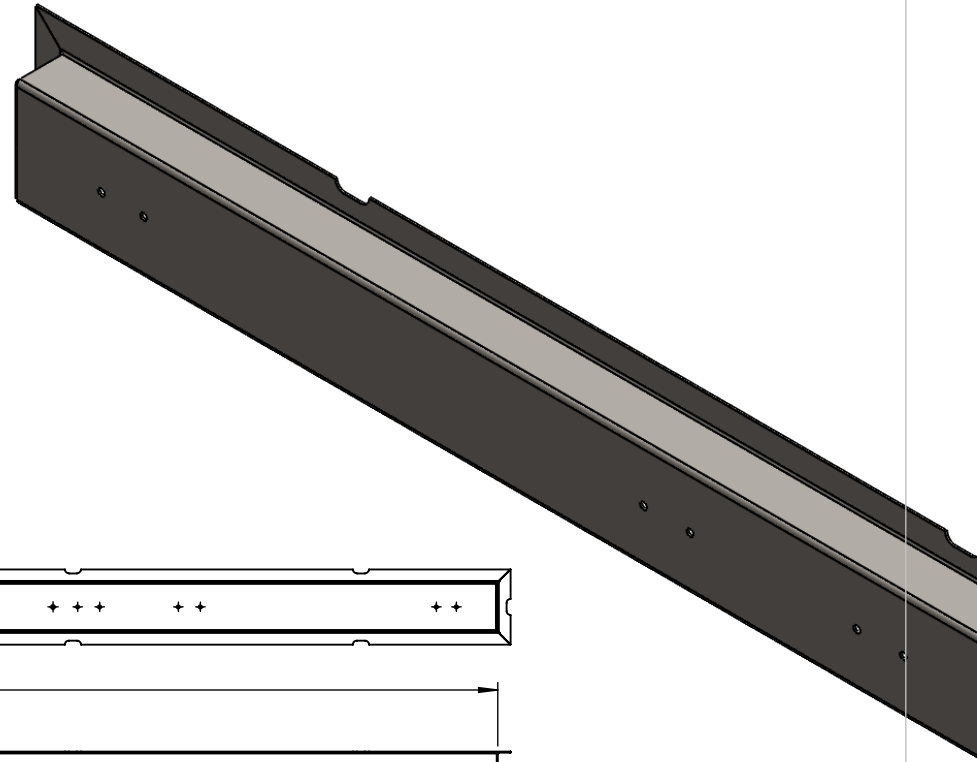

**PROPRIETARY AND CONFIDENTIAL**  
THE INFORMATION CONTAINED IN THIS DRAWING IS THE SOLE PROPERTY OF <INSERT COMPANY NAME HERE>. ANY REPRODUCTION IN PART OR AS A WHOLE WITHOUT THE WRITTEN PERMISSION OF <INSERT COMPANY NAME HERE> IS PROHIBITED.

		UNLESS OTHERWISE SPECIFIED:		NAME	DATE
		DIMENSIONS ARE IN INCHES	DRAWN		
		TOLERANCES:	CHECKED		
		FRACTIONAL ±	ENG APPR.		
		ANGULAR: MACH ± BEND ±	MFG APPR.		
		TWO PLACE DECIMAL ±	Q.A.		
		THREE PLACE DECIMAL ±	COMMENTS:		
		INTERPRET GEOMETRIC TOLERANCING PER:			
		MATERIAL			
NEXT ASSY	USED ON	FINISH			
APPLICATION		DO NOT SCALE DRAWING			

22 GAUGE

TITLE:

LIN-SQ48"-24W-MN-WF-AEC-DIM-WET-41K

SIZE	DWG. NO.	REV
<b>A</b>		
SCALE: 1:6	WEIGHT:	SHEET 7 OF 8

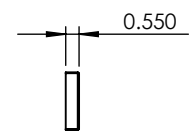
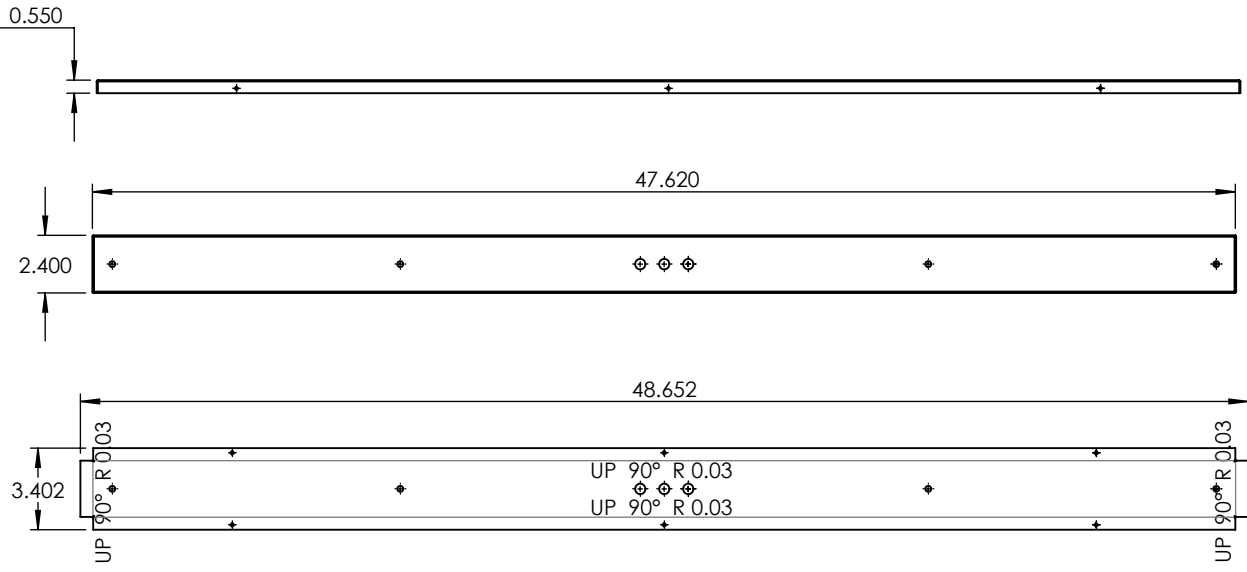
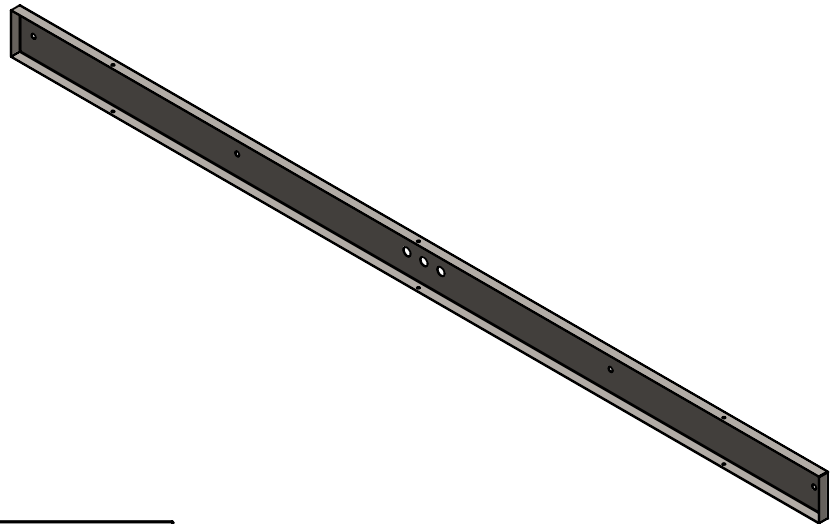

**PROPRIETARY AND CONFIDENTIAL**  
 THE INFORMATION CONTAINED IN THIS DRAWING IS THE SOLE PROPERTY OF <INSERT COMPANY NAME HERE>. ANY REPRODUCTION IN PART OR AS A WHOLE WITHOUT THE WRITTEN PERMISSION OF <INSERT COMPANY NAME HERE> IS PROHIBITED.

		UNLESS OTHERWISE SPECIFIED:	NAME	DATE
		DIMENSIONS ARE IN INCHES	DRAWN	
		TOLERANCES:	CHECKED	
		FRACTIONAL ±	ENG APPR.	
		ANGULAR: MACH ± BEND ±	MFG APPR.	
		TWO PLACE DECIMAL ±	Q.A.	
		THREE PLACE DECIMAL ±	COMMENTS:	
		INTERPRET GEOMETRIC TOLERANCING PER:		
		MATERIAL		
NEXT ASSY	USED ON	FINISH		
APPLICATION		DO NOT SCALE DRAWING		

22 GAUGE

TITLE:  
 LIN-SQ48"-24W-MN-WF-AEC-DIM-WET-41K

SIZE	DWG. NO.	REV
<b>A</b>		
SCALE: 1:8	WEIGHT:	SHEET 8 OF 8