

ITEM NO.	PART NUMBER	DESCRIPTION	QTY.	CUT
1	BOLEXT-40"-10L-TBR-GR-30K-FRONT PLATE	ALUMINUM 0.125" PLATE	1	
2	BOLEXT-40"-10L-TBR-GR-30K-BACK PLATE	ALUMINUM 0.125" PLATE	1	
3	BOLEXT-40"-10L-TBR-GR-30K-SIDES PLATE	ALUMINUM 0.125" PLATE	2	
4	BOLEXT-40"-10L-TBR-GR-30K-TOP COVER	ALUMINUM 0.125" PLATE	1	
5	BOLEXT-40"-10L-TBR-GR-30K-ANCHOR PLATE	ALUMINUM 0.125" PLATE	1	
6	BOLEXT-40"-10L-TBR-GR-30K-ANCHOR SIDE PLATE	ALUMINUM 0.125" PLATE	2	
7	BOLEXT-40"-10L-TBR-GR-30K-ANCHOR FRONT PLATE	ALUMINUM 0.125" PLATE	2	
8	BOLEXT-40"-10L-TBR-GR-30K-CAP BRACKET	ALUMINUM 0.0635"	1	
9	BOLEXT-40"-10L-TBR-GR-30K-LED BRACKET	ALUMINUM 0.0635"	1	
10	BOLEXT-40"-10L-TBR-GR-30K-LED PLATE	ALUMINUM 0.0635"	1	
11	BOLEXT-40"-10L-TBR-GR-30K-ACRYLIC	ACRYLIC	1	
12	Espen VEL19070MVH-1	DRIVER	1	
13	AltaiLED_PN1010_RevD	LED	2	

UNLESS OTHERWISE SPECIFIED:

DIMENSIONS ARE IN INCHES
 TOLERANCES:
 FRACTIONAL ± .003
 ANGULAR: MACH ± .01 BEND ±
 TWO PLACE DECIMAL ±
 THREE PLACE DECIMAL ±.001

INTERPRET GEOMETRIC
 TOLERANCING PER:

MATERIAL

FINISH

NAME DATE

DRAWN
 CHECKED
 ENG APPR.
 MFG APPR.

Q.A.
 COMMENTS:

TITLE:

BOLEXT-40"-10L-TBR-GR-30K

SIZE DWG. NO. REV

A TICKET 25010

SCALE: 1:12 WEIGHT: SHEET 1 OF 8



ALL BEND RADIUS .030"

APPLICATION

DO NOT SCALE DRAWING

5

4

3

2

1

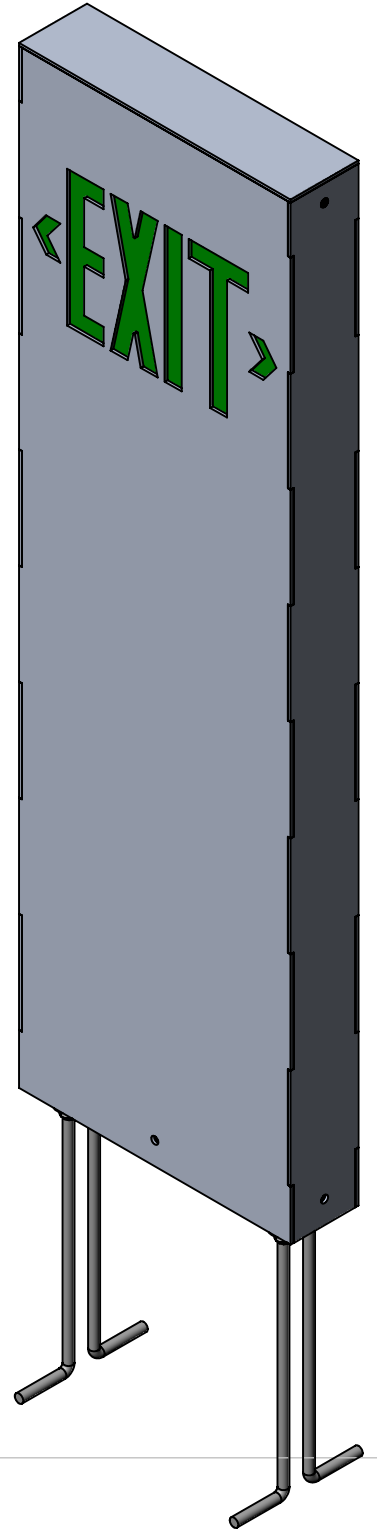
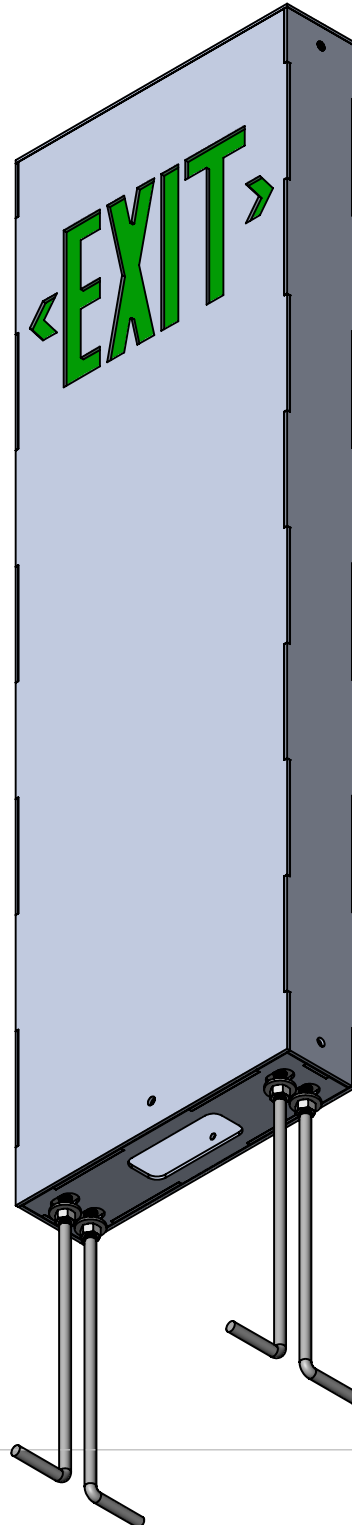
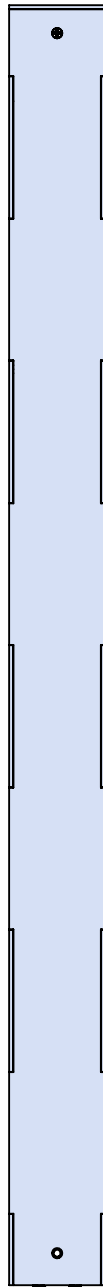
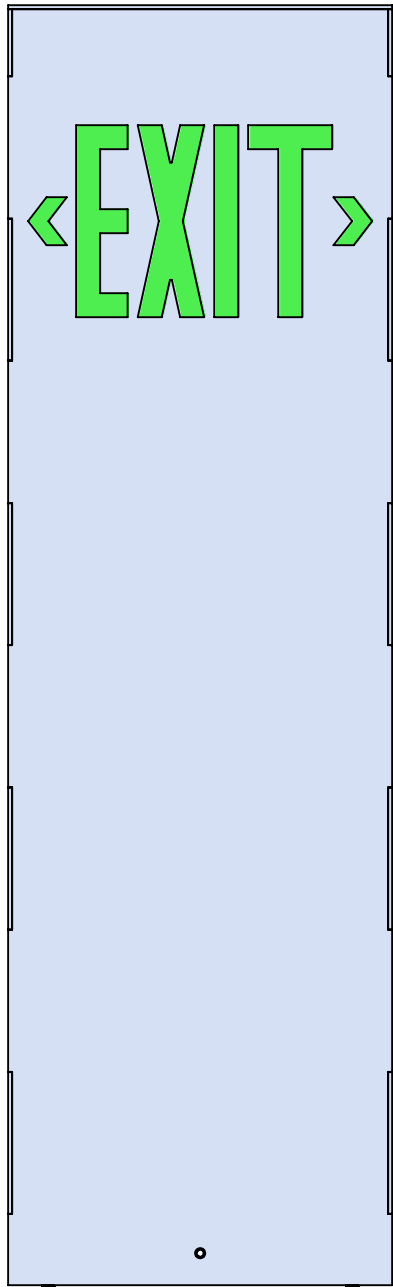

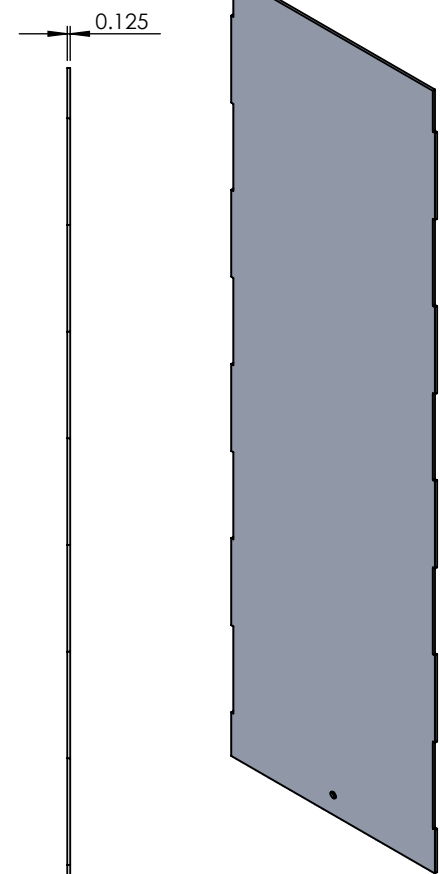
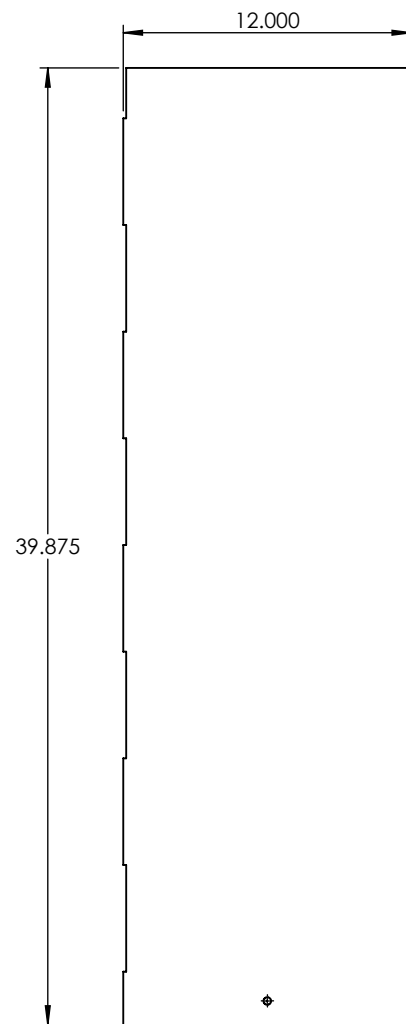
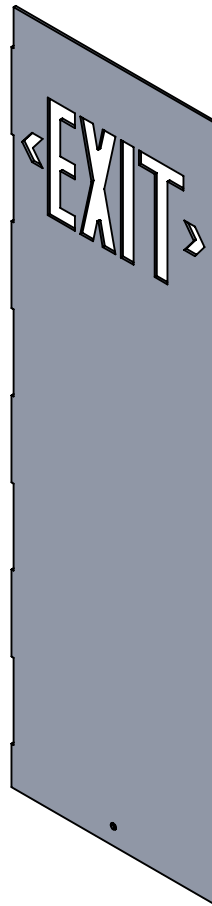
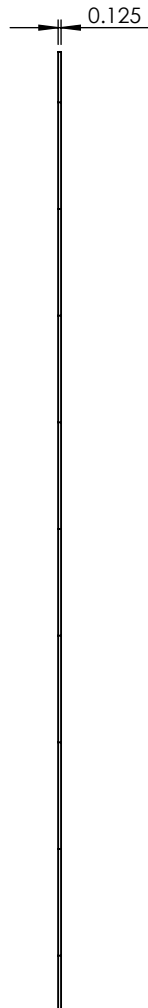
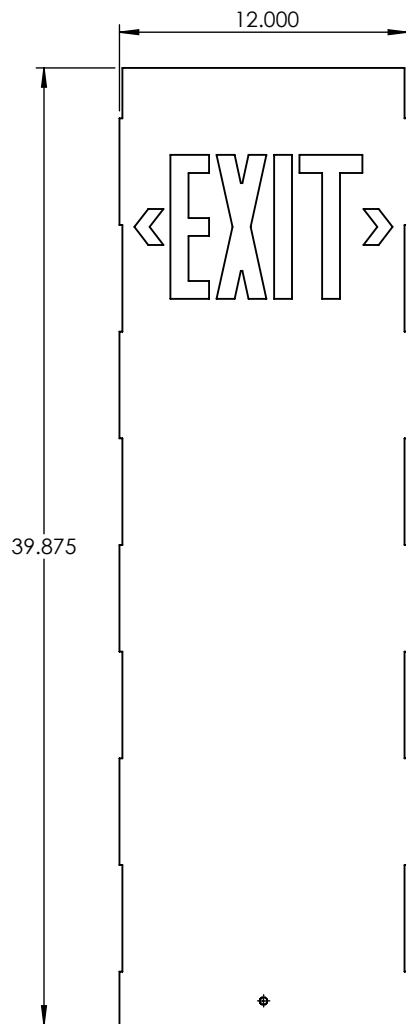

PROPRIETARY AND CONFIDENTIAL
 THE INFORMATION CONTAINED IN THIS DRAWING IS THE SOLE PROPERTY OF <INSERT COMPANY NAME HERE>. ANY REPRODUCTION IN PART OR AS A WHOLE WITHOUT THE WRITTEN PERMISSION OF <INSERT COMPANY NAME HERE> IS PROHIBITED.

		UNLESS OTHERWISE SPECIFIED:		NAME	DATE
		DIMENSIONS ARE IN INCHES	DRAWN		
		TOLERANCES:	CHECKED		
		FRACTIONAL ±	ENG APPR.		
		ANGULAR: MACH ± BEND ±	MFG APPR.		
		TWO PLACE DECIMAL ±	Q.A.		
		THREE PLACE DECIMAL ±	COMMENTS:		
		INTERPRET GEOMETRIC TOLERANCING PER:			
		MATERIAL			
NEXT ASSY	USED ON	FINISH			
APPLICATION		DO NOT SCALE DRAWING			

ALUMINUM 0.125" PLATE

TITLE:

BOLEXT-40"-10L-TBR-GR-30K

SIZE	DWG. NO.	REV
A		
SCALE: 1:8	WEIGHT:	SHEET 3 OF 8

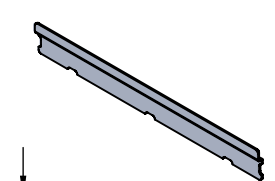
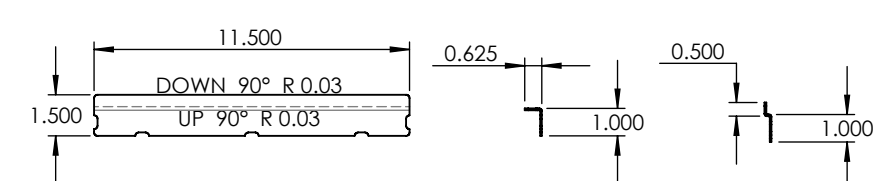
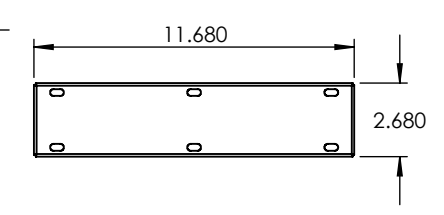
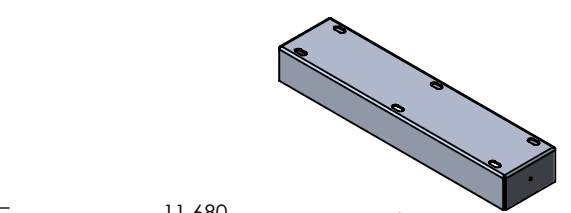
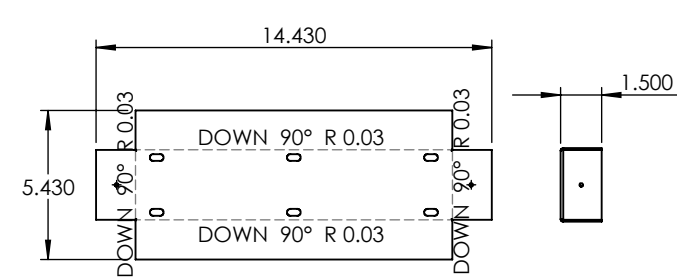
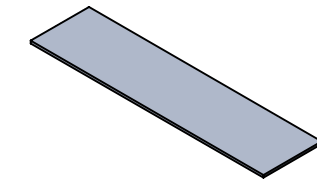
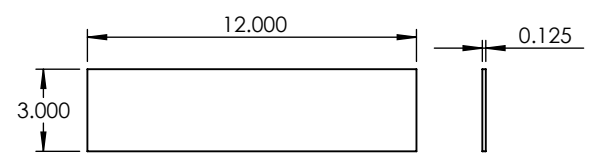
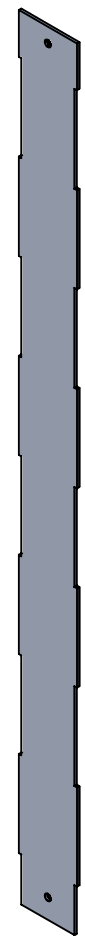
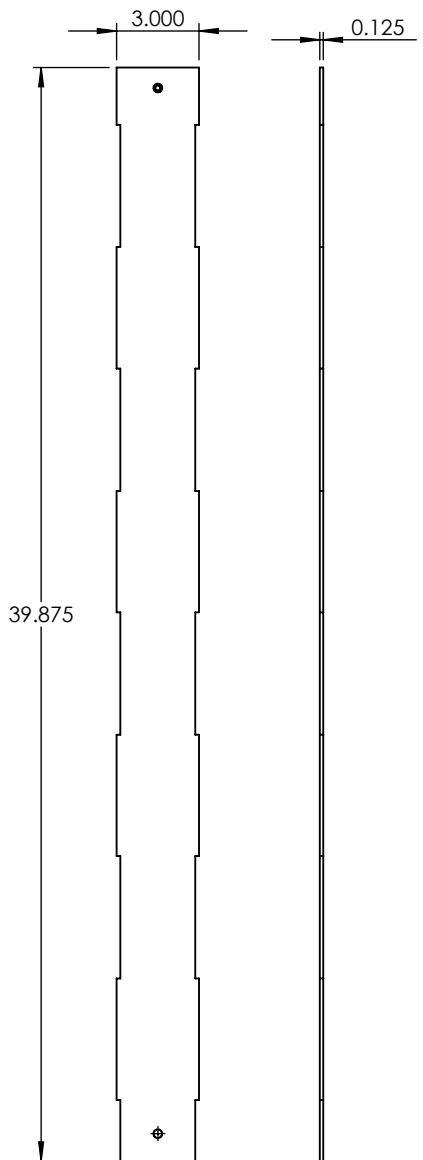

PROPRIETARY AND CONFIDENTIAL
 THE INFORMATION CONTAINED IN THIS DRAWING IS THE SOLE PROPERTY OF <INSERT COMPANY NAME HERE>. ANY REPRODUCTION IN PART OR AS A WHOLE WITHOUT THE WRITTEN PERMISSION OF <INSERT COMPANY NAME HERE> IS PROHIBITED.

		UNLESS OTHERWISE SPECIFIED:	NAME	DATE
		DIMENSIONS ARE IN INCHES	DRAWN	
		TOLERANCES:	CHECKED	
		FRACTIONAL ±	ENG APPR.	
		ANGULAR: MACH ± BEND ±	MFG APPR.	
		TWO PLACE DECIMAL ±	Q.A.	
		THREE PLACE DECIMAL ±	COMMENTS:	
		INTERPRET GEOMETRIC TOLERANCING PER:		
		MATERIAL		
NEXT ASSY	USED ON	FINISH		
APPLICATION		DO NOT SCALE DRAWING		

ALUMINUM 0.125" PLATE		
TITLE:		
BOLEXT-40"-10L-TBR-GR-30K		
SIZE	DWG. NO.	REV
A		
SCALE: 1:7	WEIGHT:	SHEET 4 OF 8

5

4

3

2

1

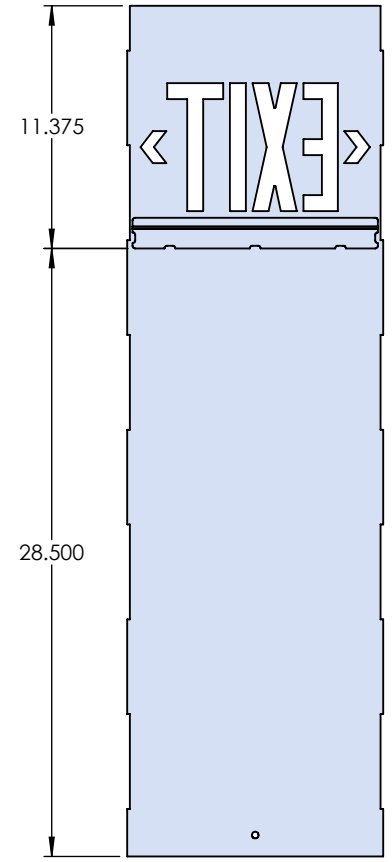
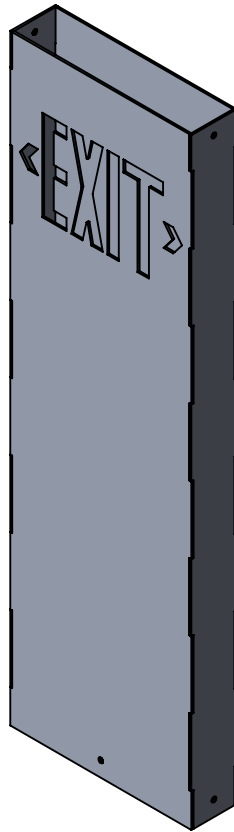
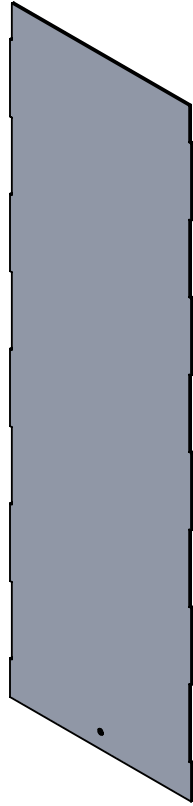
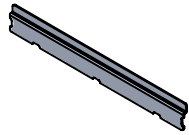
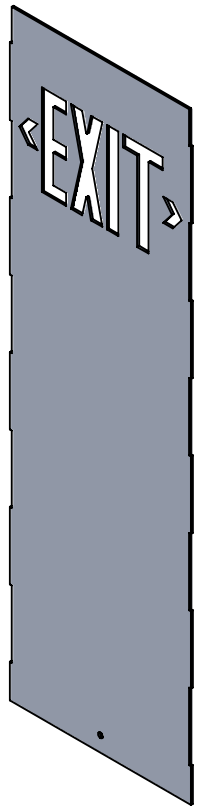

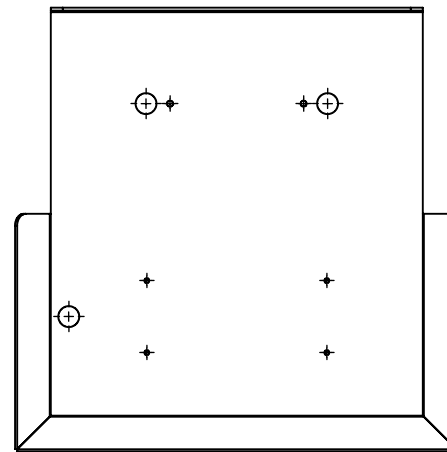
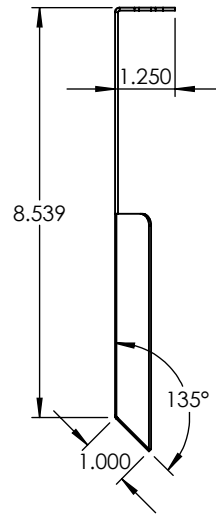
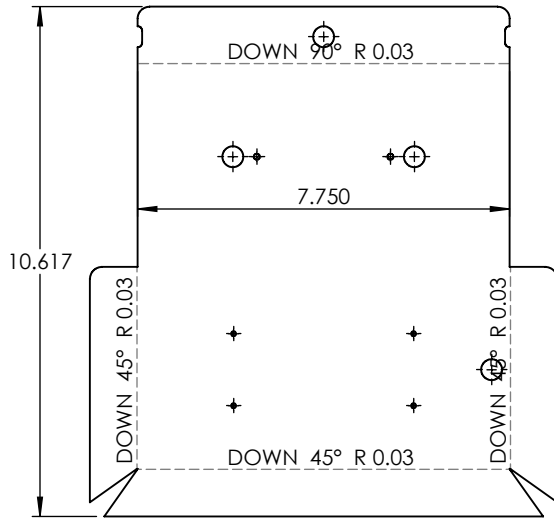
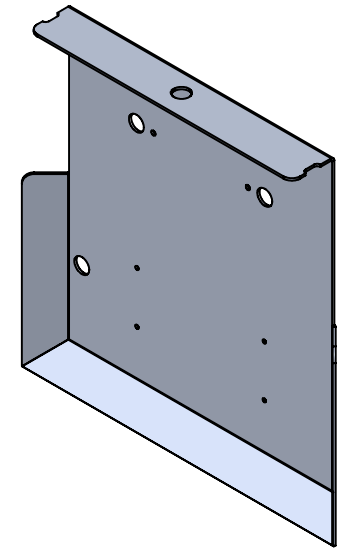

UNLESS OTHERWISE SPECIFIED:

DIMENSIONS ARE IN INCHES
 TOLERANCES:
 FRACTIONAL ±
 ANGULAR: MACH ± BEND ±
 TWO PLACE DECIMAL ±
 THREE PLACE DECIMAL ±

INTERPRET GEOMETRIC
 TOLERANCING PER:

MATERIAL

FINISH

DO NOT SCALE DRAWING

NAME

DATE

ALUMINUM 0.0635"

TITLE:

BOLEXT-40"-10L-TBR-GR-30K

DRAWN

CHECKED

ENG APPR.

MFG APPR.

Q.A.

COMMENTS:

PROPRIETARY AND CONFIDENTIAL

THE INFORMATION CONTAINED IN THIS
 DRAWING IS THE SOLE PROPERTY OF
 <INSERT COMPANY NAME HERE>. ANY
 REPRODUCTION IN PART OR AS A WHOLE
 WITHOUT THE WRITTEN PERMISSION OF
 <INSERT COMPANY NAME HERE> IS
 PROHIBITED.

NEXT ASSY

USED ON

APPLICATION

SIZE
A

DWG. NO.

REV

SCALE: 1:4

WEIGHT:

SHEET 6 OF 8

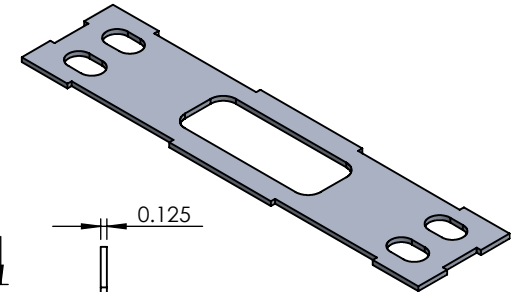
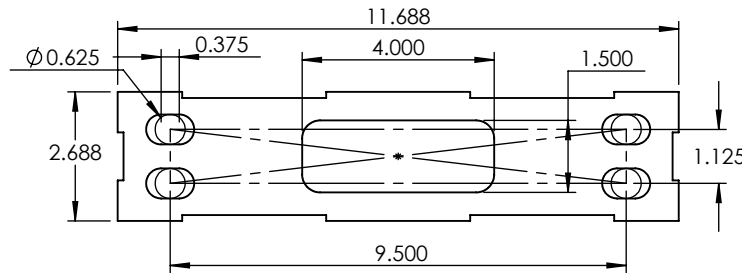
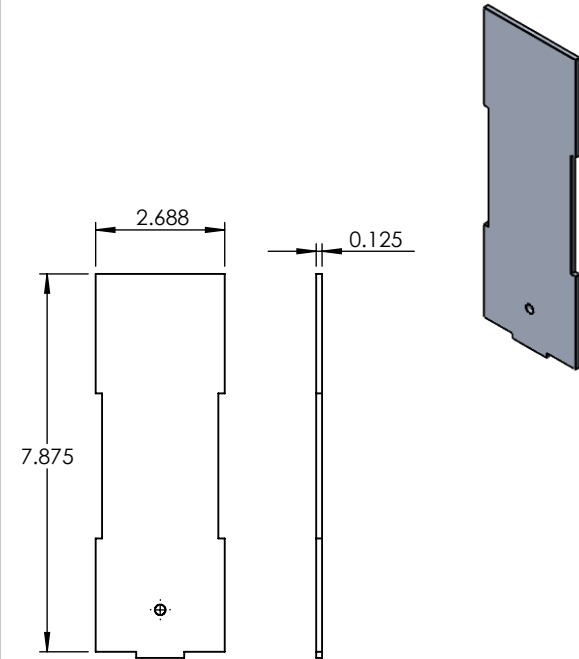
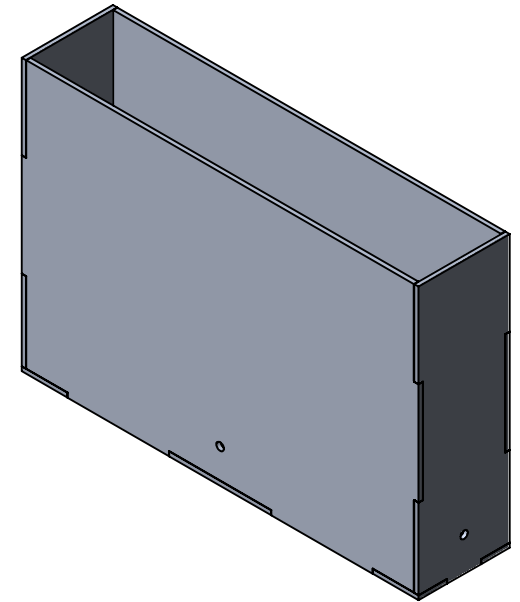
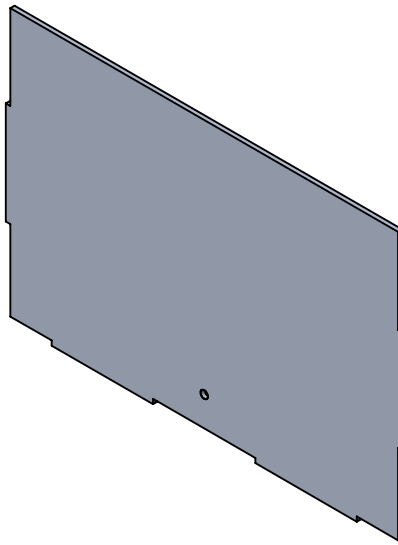
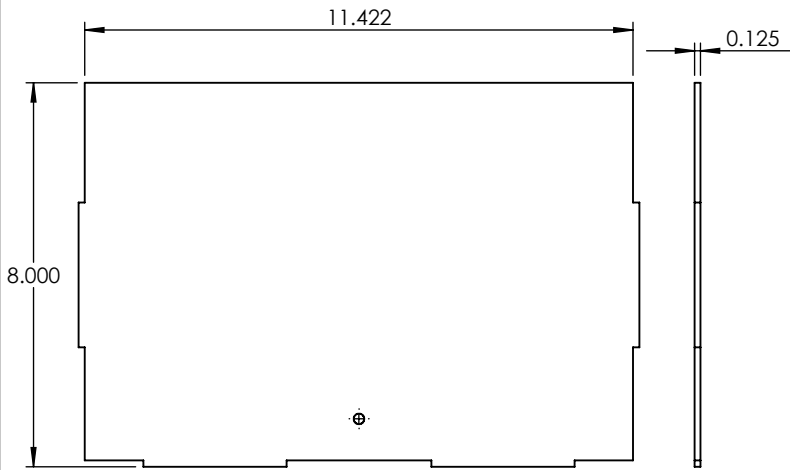

UNLESS OTHERWISE SPECIFIED:

DIMENSIONS ARE IN INCHES
 TOLERANCES:
 FRACTIONAL ±
 ANGULAR: MACH ± BEND ±
 TWO PLACE DECIMAL ±
 THREE PLACE DECIMAL ±

INTERPRET GEOMETRIC
 TOLERANCING PER:

MATERIAL

FINISH

DO NOT SCALE DRAWING

NAME DATE

DRAWN
 CHECKED
 ENG APPR.
 MFG APPR.

Q.A.
 COMMENTS:

ALUMINUM 0.125" PLATE

TITLE:

BOLEXT-40"-10L-TBR-GR-30K

SIZE DWG. NO.

REV

A

SCALE: 1:4 WEIGHT:

SHEET 7 OF 8

PROPRIETARY AND CONFIDENTIAL
 THE INFORMATION CONTAINED IN THIS
 DRAWING IS THE SOLE PROPERTY OF
 <INSERT COMPANY NAME HERE>. ANY
 REPRODUCTION IN PART OR AS A WHOLE
 WITHOUT THE WRITTEN PERMISSION OF
 <INSERT COMPANY NAME HERE> IS
 PROHIBITED.

NEXT ASSY	USED ON
APPLICATION	

5

4

3

2

1

ALL PLATES WELDED THOROUGHLY

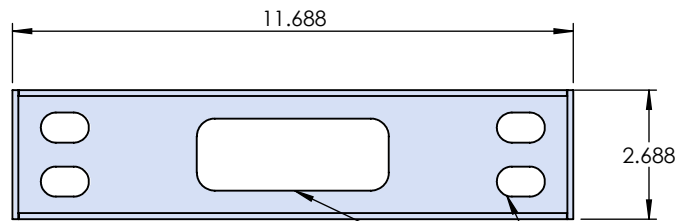
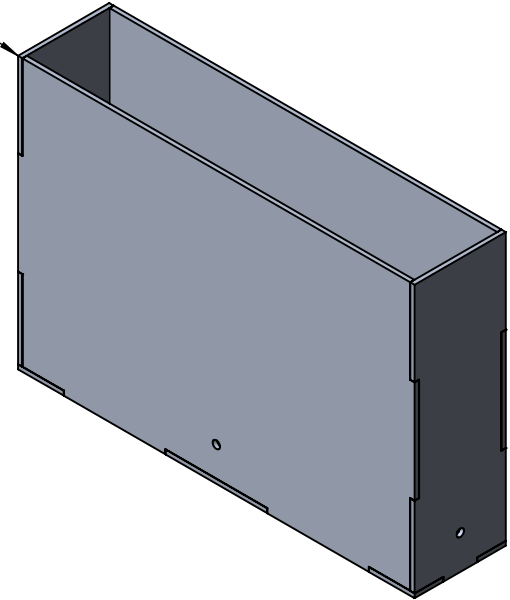

ALL HOLE LOCATIONS AS PER ORIGINAL ANCHOR

