

ITEM NO.	PART NUMBER	DESCRIPTION	QTY.	CUT
1	LDSCP18-PST-44L-MBK-CFA-14AB4-RD-120V-20AGFICR-DRIVER BRACKET	ALUMINUM 0.0635"	1	
2	LDSCP18-PST-44L-MBK-CFA-14AB4-RD-120V-20AGFICR-LED PLATE	ALUMINUM 0.125" PLATE	1	
3	LDSCP18-PST-44L-MBK-CFA-14AB4-RD-120V-20AGFICR-SPUN LED BRACKET	SPUN ALUMINUM 0.080"	1	
4	LDSCP18-PST-44L-MBK-CFA-14AB4-RD-120V-20AGFICR-SPUN TOP COVER	SPUN ALUMINUM 0.125"	1	
5	LDSCP18-PST-44L-MBK-CFA-14AB4-RD-120V-20AGFICR-SPUN SEAT BOWL	SPUN ALUMINUM 0.125"	1	
6	ALC-B-MD-20W-42"-MBK-CFA-41K-SPACER TUBE ARMS	3/4" SQUARE ALUMINUM TUBE	1	
7	ALC-B-MD-20W-42"-MBK-CFA-41K-SPACER BAR ARMS	3/4" SQUARE ALUMINUM BAR	3	
8	LDSCP18-PST-44L-MBK-CFA-14AB4-RD-120V-20AGFICR-ACRYLIC	ACRYLIC	1	
9	4" POST FITTER	POST FITTER	1	
10	Altal_LED_PN1019_SHIM PLATE	ALUMINUM 0.125" PLATE	6	
11	ESPEN VEL29070MVH-1	DRIVER	3	
12	Altal_LED_PN1019_RevC	LED	6	

UNLESS OTHERWISE SPECIFIED:

DIMENSIONS ARE IN INCHES
 TOLERANCES:
 FRACTIONAL ± .003
 ANGULAR: MACH ± .01 BEND ±
 TWO PLACE DECIMAL ±
 THREE PLACE DECIMAL ±.001

INTERPRET GEOMETRIC
 TOLERANCING PER:
 MATERIAL

FINISH

	NAME	DATE
DRAWN		
CHECKED		
ENG APPR.		
MFG APPR.		
Q.A.		
COMMENTS:		

TITLE:

LDSCP18-PST-44L-MBK-CFA-14AB4-RD-120V-20AG

SIZE DWG. NO. REV

A TICKET 24968

SCALE: 1:10 WEIGHT: SHEET 1 OF 8

EVERGREEN LIGHTING

ALL BEND RADIUS .030"

APPLICATION

DO NOT SCALE DRAWING

5

4

3

2

1

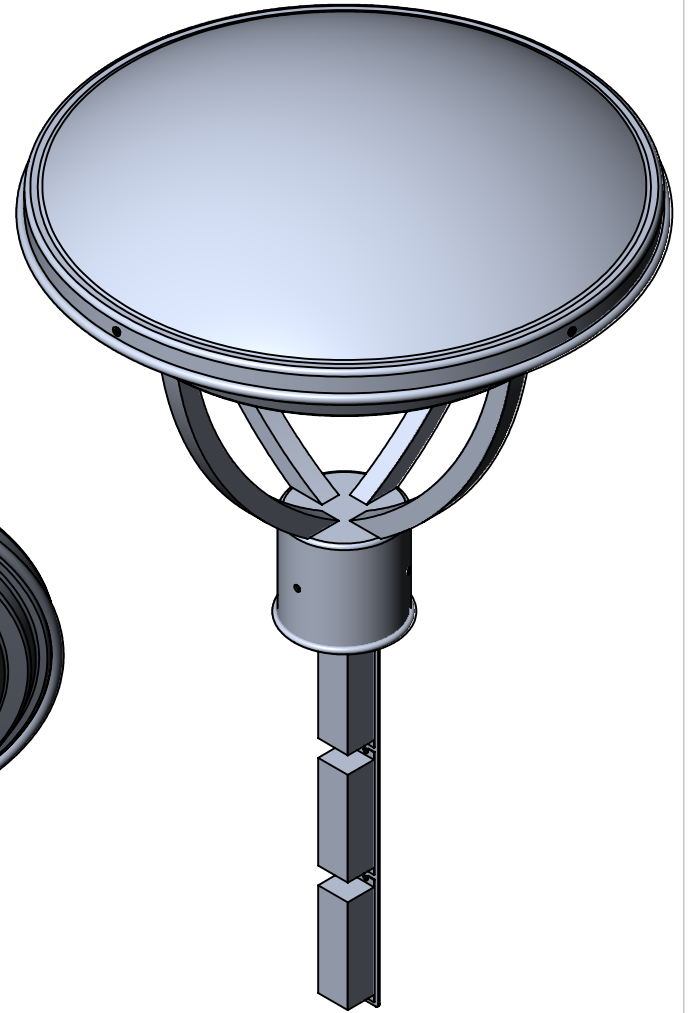
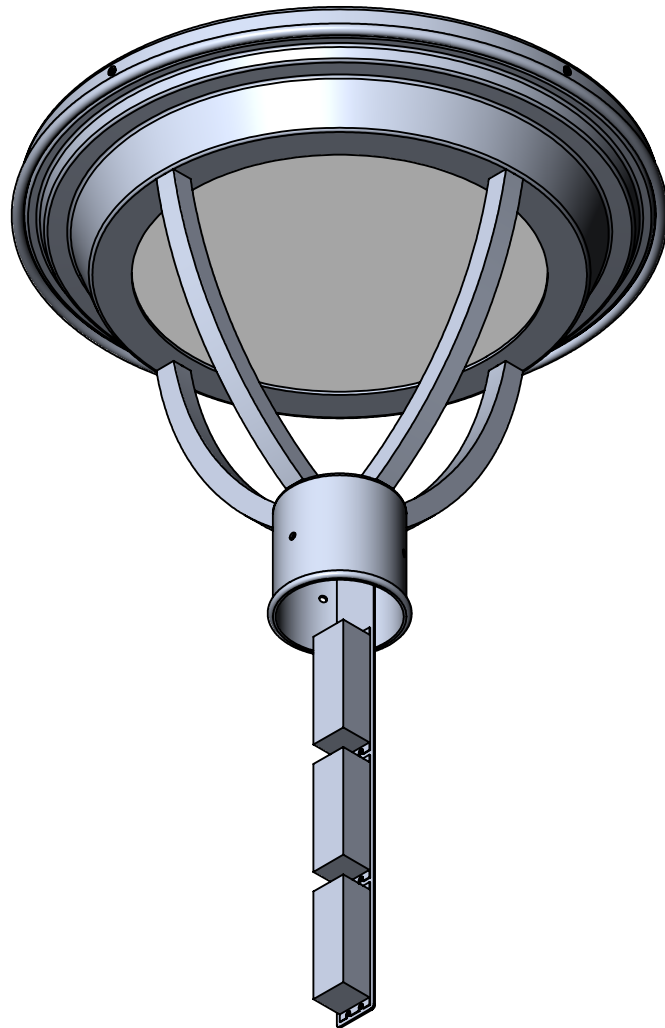
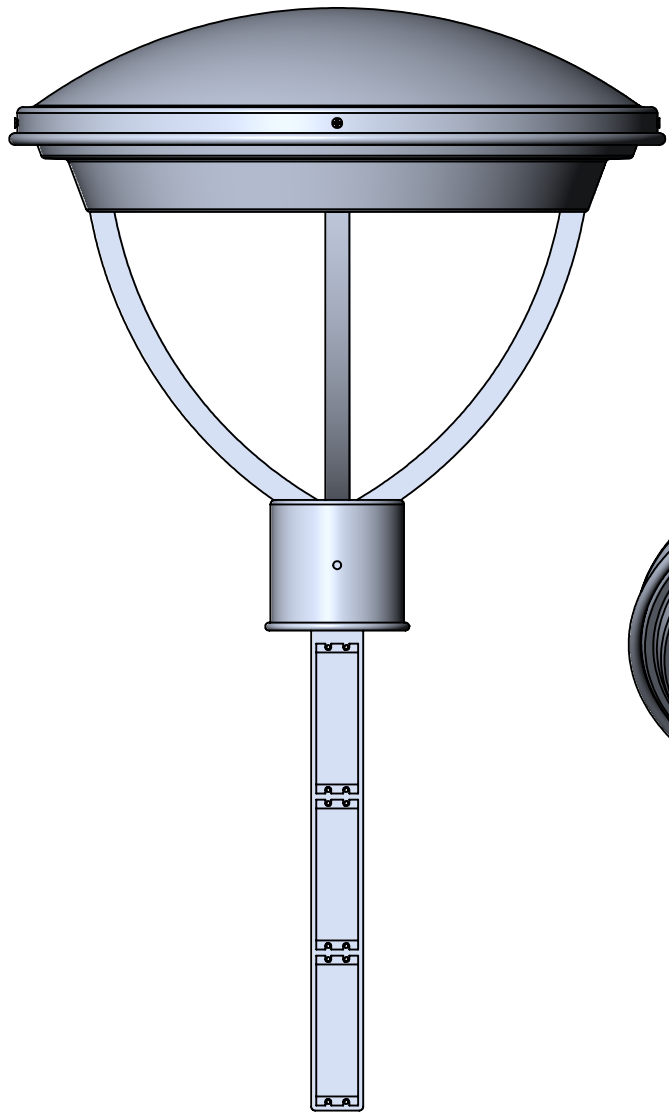

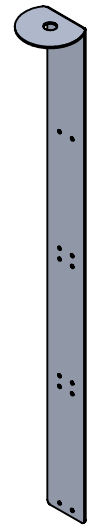
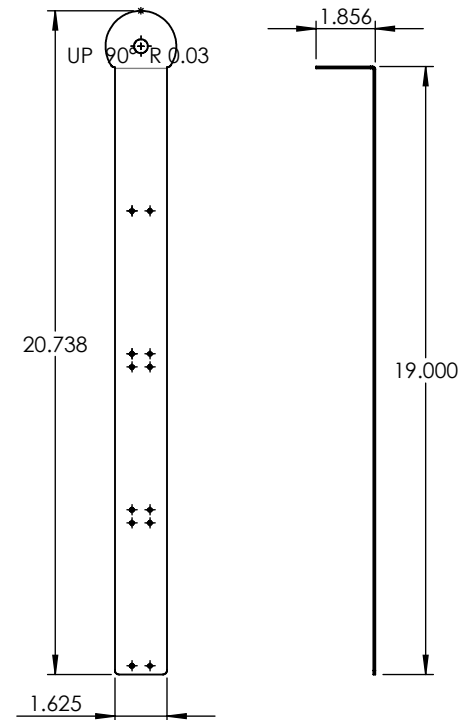
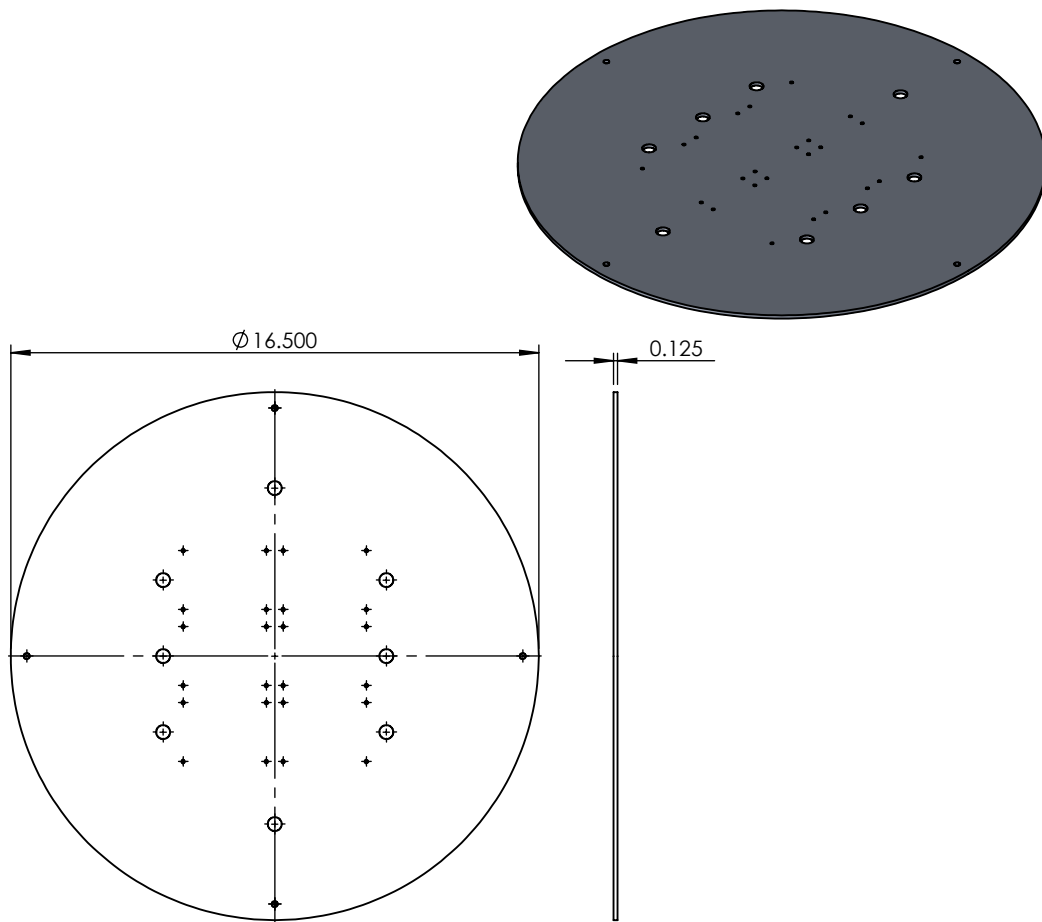

PROPRIETARY AND CONFIDENTIAL
 THE INFORMATION CONTAINED IN THIS DRAWING IS THE SOLE PROPERTY OF <INSERT COMPANY NAME HERE>. ANY REPRODUCTION IN PART OR AS A WHOLE WITHOUT THE WRITTEN PERMISSION OF <INSERT COMPANY NAME HERE> IS PROHIBITED.

		UNLESS OTHERWISE SPECIFIED:	NAME	DATE	ALUMINUM 0.125" PLATE	
		DIMENSIONS ARE IN INCHES TOLERANCES: FRACTIONAL ± ANGULAR: MACH ± BEND ± TWO PLACE DECIMAL ± THREE PLACE DECIMAL ±	DRAWN			
		INTERPRET GEOMETRIC TOLERANCING PER:	CHECKED		LDSCP18-PST-44L-MBK-CFA-14AB4-RD-120V-20AG	
		MATERIAL	ENG APPR.			
		FINISH	MFG APPR.		SIZE	DWG. NO.
NEXT ASSY	USED ON	APPLICATION	COMMENTS:		A	REV
		DO NOT SCALE DRAWING			SCALE: 1:6	WEIGHT:
					SHEET 3 OF 8	

5

4

3

2

1

ITEM NO.	PART NUMBER	DESCRIPTION	QTY.
1	4" POST FITTER	POST FITTER	1

1/8" ALUMINUM

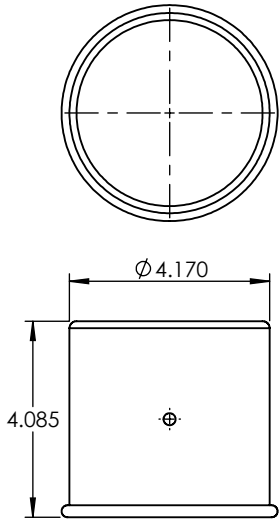
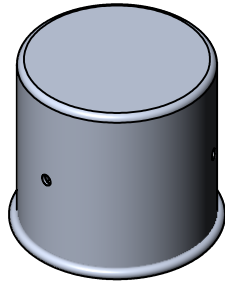

3X

1X

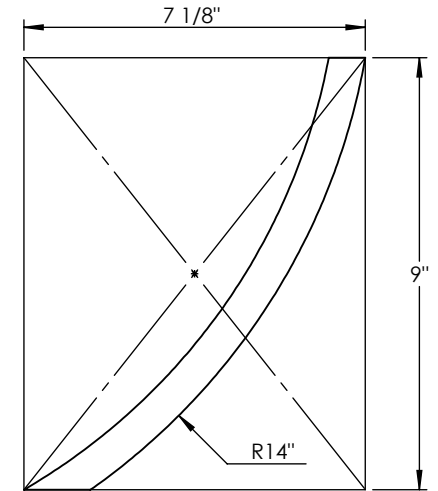
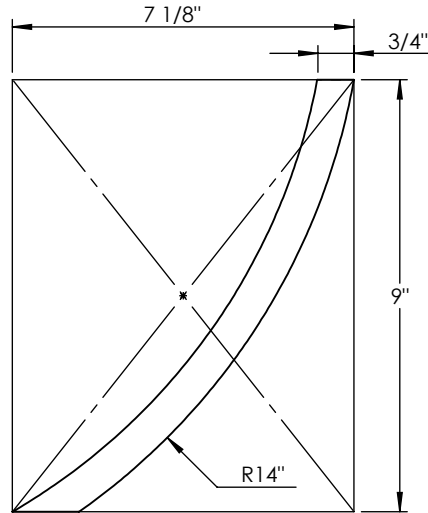
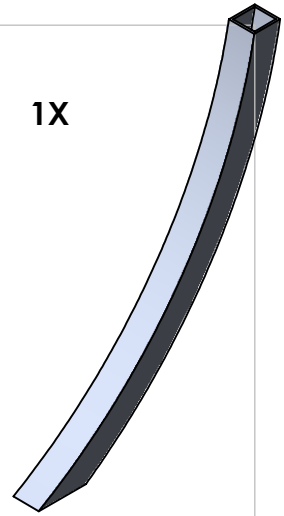
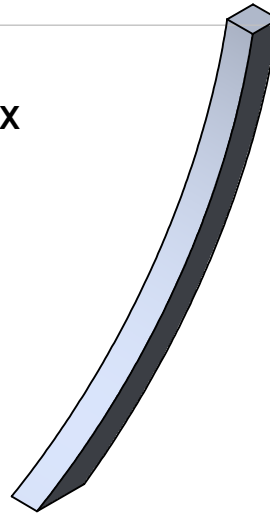

UNLESS OTHERWISE SPECIFIED:

DIMENSIONS ARE IN INCHES
 TOLERANCES:
 FRACTIONAL ±
 ANGULAR: MACH ± BEND ±
 TWO PLACE DECIMAL ±
 THREE PLACE DECIMAL ±

INTERPRET GEOMETRIC
 TOLERANCING PER:

MATERIAL

FINISH

DO NOT SCALE DRAWING

NAME DATE

DRAWN
 CHECKED
 ENG APPR.
 MFG APPR.

Q.A.
 COMMENTS:

POST FITTER

TITLE:

LDSCP18-PST-44L-MBK-CFA-14AB4-RD-120V-20AG

PROPRIETARY AND CONFIDENTIAL

THE INFORMATION CONTAINED IN THIS
 DRAWING IS THE SOLE PROPERTY OF
 <INSERT COMPANY NAME HERE>. ANY
 REPRODUCTION IN PART OR AS A WHOLE
 WITHOUT THE WRITTEN PERMISSION OF
 <INSERT COMPANY NAME HERE> IS
 PROHIBITED.

NEXT ASSY	USED ON
APPLICATION	

SIZE A	DWG. NO.	REV
SCALE: 1:4	WEIGHT:	SHEET 4 OF 8

5

4

3

2

1

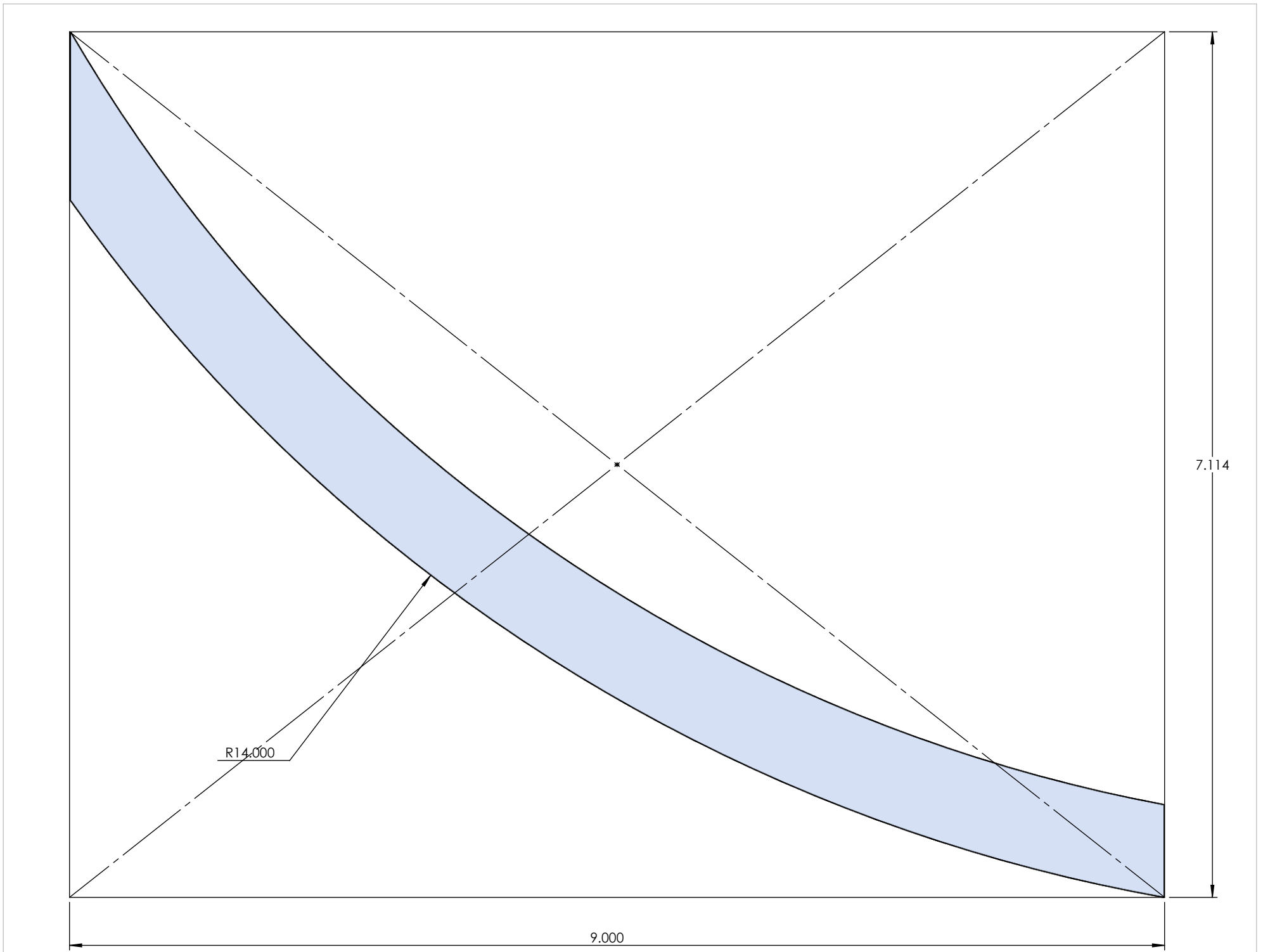

ITEM NO.	PART NUMBER	DESCRIPTION	QTY.
1	LDSCP18-PST-44L-MBK-CFA-14AB4-RD-120V-20AGFCR-SPUN SEAT BOWL	SPUN ALUMINUM 0.125"	1

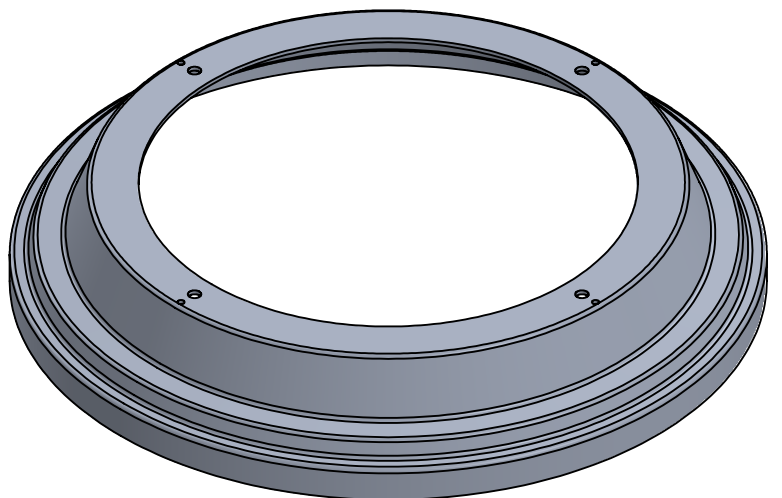
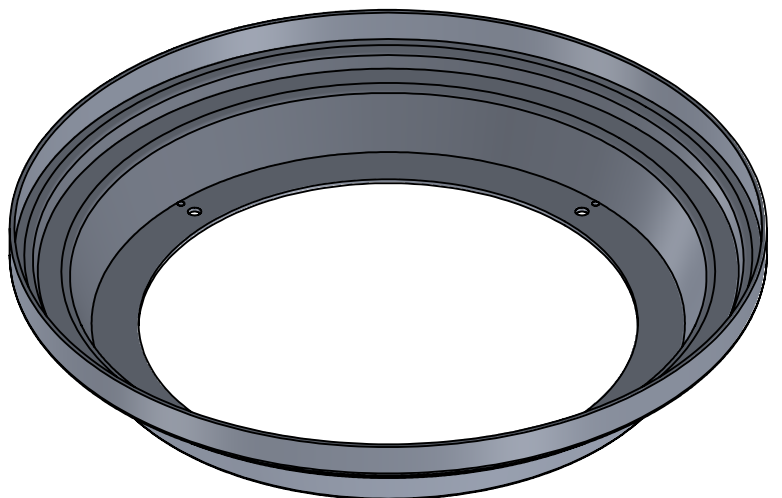
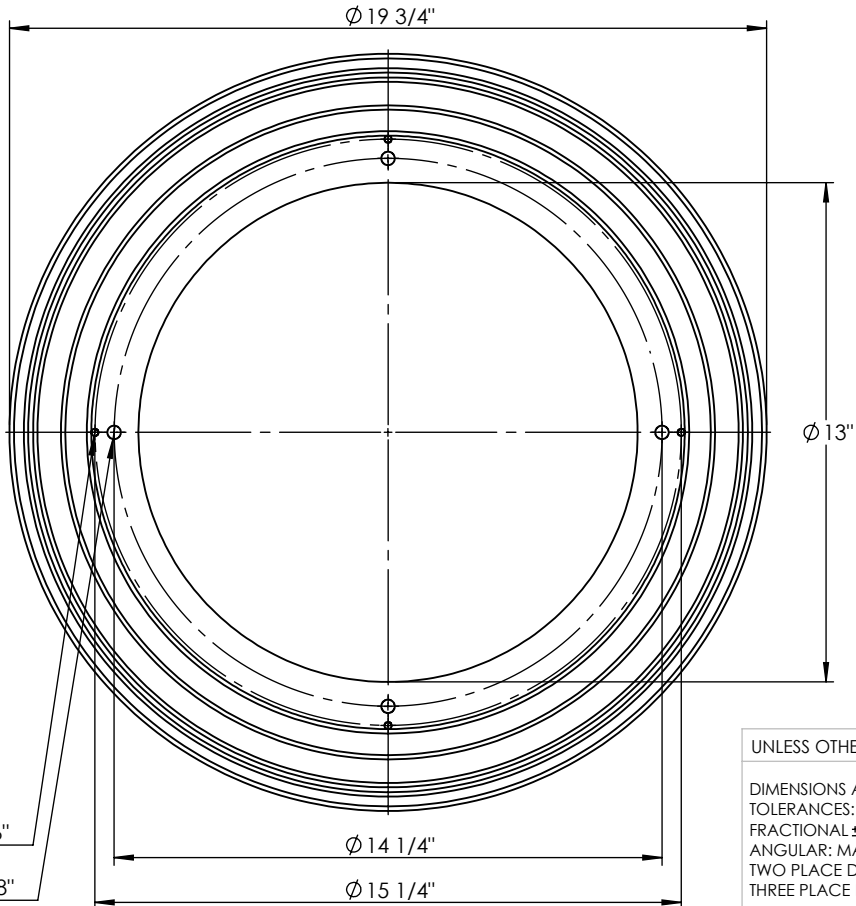
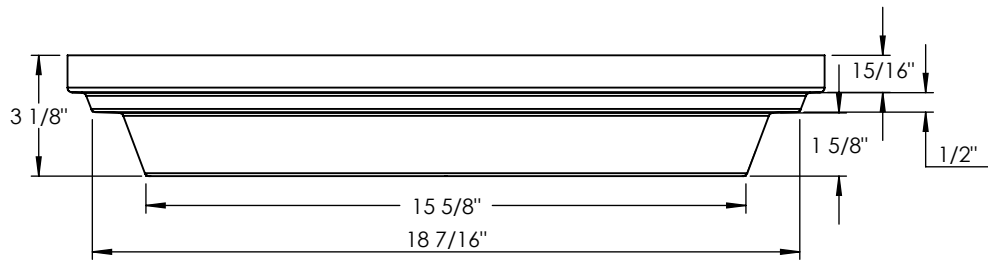

4 X $\phi 3/16$ "
4 X $\phi 3/8$ "

UNLESS OTHERWISE SPECIFIED:
DIMENSIONS ARE IN INCHES
TOLERANCES:
FRACTIONAL \pm
ANGULAR: MACH \pm BEND \pm
TWO PLACE DECIMAL \pm
THREE PLACE DECIMAL \pm

INTERPRET GEOMETRIC TOLERANCING PER:
MATERIAL
FINISH
DO NOT SCALE DRAWING

PROPRIETARY AND CONFIDENTIAL
THE INFORMATION CONTAINED IN THIS DRAWING IS THE SOLE PROPERTY OF <INSERT COMPANY NAME HERE>. ANY REPRODUCTION IN PART OR AS A WHOLE WITHOUT THE WRITTEN PERMISSION OF <INSERT COMPANY NAME HERE> IS PROHIBITED.

NEXT ASSY	USED ON
APPLICATION	

	NAME	DATE
DRAWN		
CHECKED		
ENG APPR.		
MFG APPR.		
Q.A.		
COMMENTS:		

SPUN ALUMINUM 0.125"
TITLE:
LDSCP18-PST-44L-MBK-CFA-14AB4-RD-120V-20AG

SIZE A	DWG. NO.	REV
SCALE: 1:5	WEIGHT:	SHEET 6 OF 8

ITEM NO.	PART NUMBER	DESCRIPTION	QTY.
1	LDSCP18-PST-44L-MBK-CFA-14AB4-RD-120V-20AGFICR-SPUN TOP COVER	SPUN ALUMINUM 0.125"	1

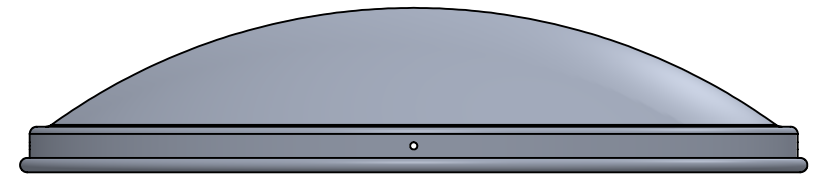
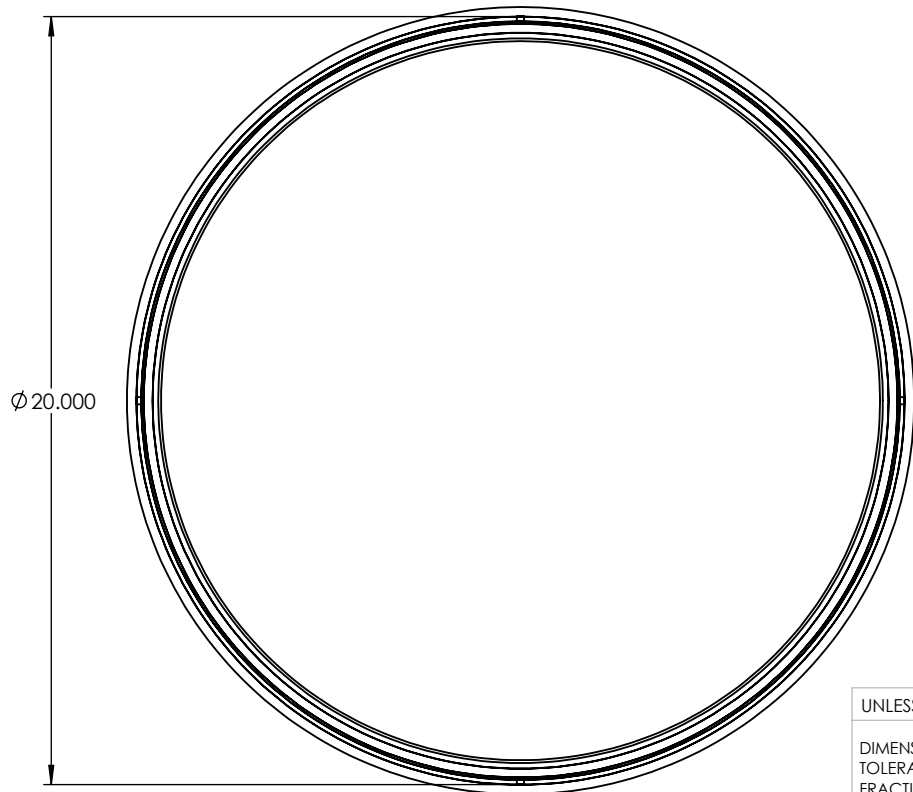
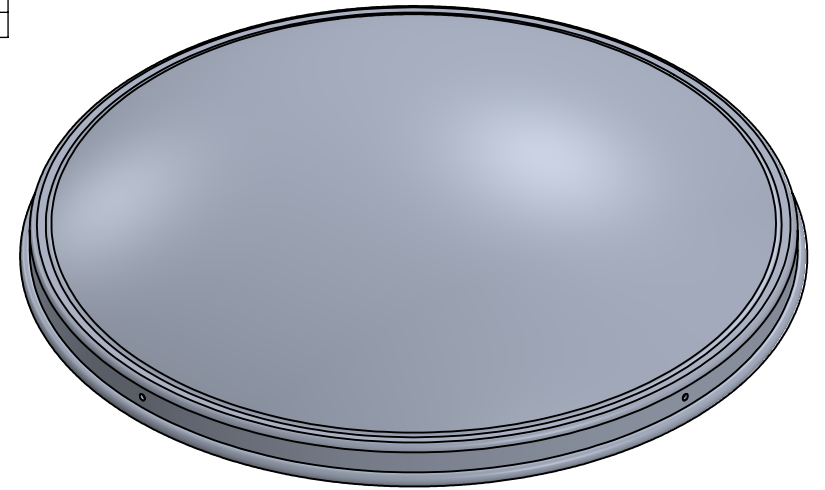
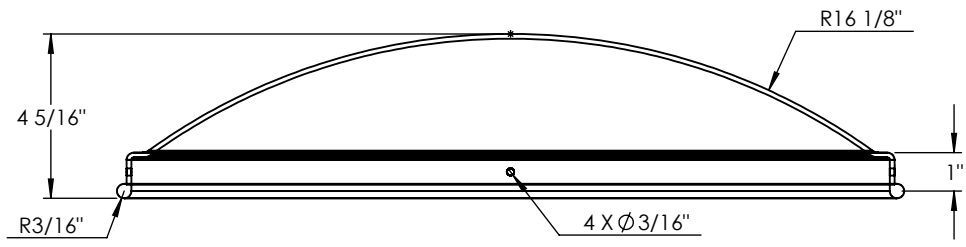

UNLESS OTHERWISE SPECIFIED:
 DIMENSIONS ARE IN INCHES
 TOLERANCES:
 FRACTIONAL ±
 ANGULAR: MACH ± BEND ±
 TWO PLACE DECIMAL ±
 THREE PLACE DECIMAL ±

	NAME	DATE
DRAWN		
CHECKED		
ENG APPR.		
MFG APPR.		

TITLE: SPUN ALUMINUM 0.125"

LDSCP18-PST-44L-MBK-CFA-14AB4-RD-120V-20AG

PROPRIETARY AND CONFIDENTIAL
 THE INFORMATION CONTAINED IN THIS DRAWING IS THE SOLE PROPERTY OF <INSERT COMPANY NAME HERE>. ANY REPRODUCTION IN PART OR AS A WHOLE WITHOUT THE WRITTEN PERMISSION OF <INSERT COMPANY NAME HERE> IS PROHIBITED.

NEXT ASSY	USED ON
APPLICATION	

INTERPRET GEOMETRIC TOLERANCING PER:
 MATERIAL
 FINISH
 DO NOT SCALE DRAWING

Q.A.
 COMMENTS:

SIZE	DWG. NO.	REV
A		
SCALE: 1:5	WEIGHT:	SHEET 7 OF 8

ITEM NO.	PART NUMBER	DESCRIPTION	QTY.
1	LDSCP18-PST-44L-MBK-CFA-14AB4-RD-120V-20AGFICR-SPUN LED BRACKET	SPUN ALUMINUM 0.080"	1

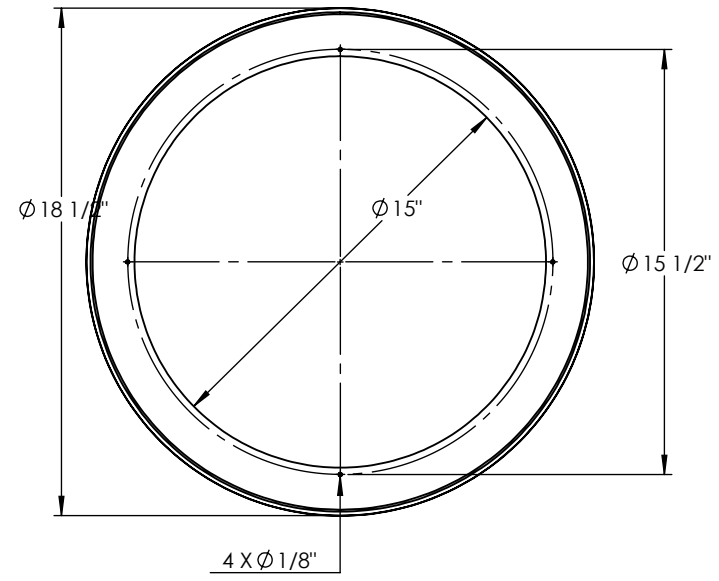
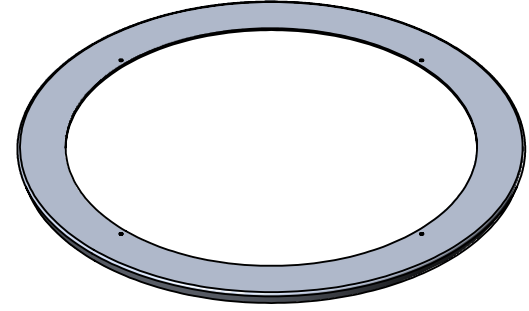
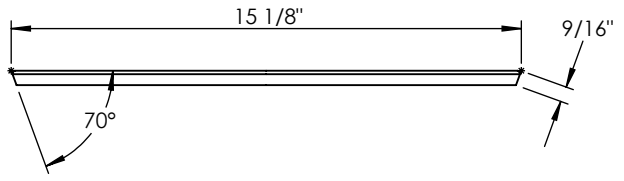

PROPRIETARY AND CONFIDENTIAL
 THE INFORMATION CONTAINED IN THIS DRAWING IS THE SOLE PROPERTY OF <INSERT COMPANY NAME HERE>. ANY REPRODUCTION IN PART OR AS A WHOLE WITHOUT THE WRITTEN PERMISSION OF <INSERT COMPANY NAME HERE> IS PROHIBITED.

		UNLESS OTHERWISE SPECIFIED:	NAME	DATE	SPUN ALUMINUM 0.080"	
		DIMENSIONS ARE IN INCHES	DRAWN		TITLE:	
		TOLERANCES:	CHECKED		LDSCP18-PST-44L-MBK-CFA-14AB4-RD-120V-20AG	
		FRACTIONAL ±	ENG APPR.		SIZE	DWG. NO.
		ANGULAR: MACH ± BEND ±	MFG APPR.		A	REV
		TWO PLACE DECIMAL ±	Q.A.		SCALE: 1:7	WEIGHT:
		THREE PLACE DECIMAL ±	COMMENTS:		SHEET 8 OF 8	
NEXT ASSY	USED ON	INTERPRET GEOMETRIC TOLERANCING PER:				
		MATERIAL				
		FINISH				
APPLICATION		DO NOT SCALE DRAWING				

5

4

3

2

1