

ITEM NO.	PART NUMBER	DESCRIPTION	QTY.	CUT
1	702106L-MBK-WF-41K-T4-CANOPY	22 GAUGE	1	
2	702106L-MBK-WF-41K-T4-FIREPLATE	22 GAUGE	1	
3	702106L-MBK-WF-41K-T4-FRAME	22 GAUGE	1	
4	702106L-MBK-WF-41K-T4-FRAME BACK	22 GAUGE	1	
5	702106L-MBK-WF-41K-T4-FRAME CAP	22 GAUGE	2	
6	702106L-MBK-WF-41K-T4-TOP CAP	22 GAUGE	1	
7	702106L-MBK-WF-41K-T4-TUBE BRACKET	22 GAUGE	1	
8	702106L-MBK-WF-41K-T4-DRIVER BRACKET	22 GAUGE	1	
9	702106L-MBK-WF-41K-T4-ACRYLIC	ACRYLIC	4	
10	702106L-MBK-WF-41K-T4-SQUARE TUBE	1" SQUARE ALUMINUM TUBE	1	
11	702106L-MBK-WF-41K-T4-SMALL TUBE	5/8" ROUND ALUMINUM TUBE	1	
14	BRASS L JOINT	BRASS JOINT	1	
15	Espen VEL19070MVH-1	DRIVER	1	
16	AltaILED_PN1012_RevD	LED	4	

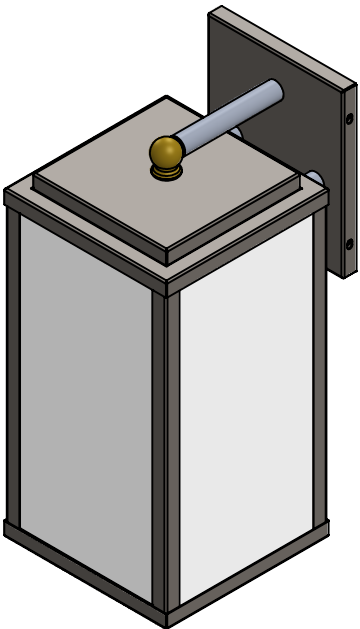
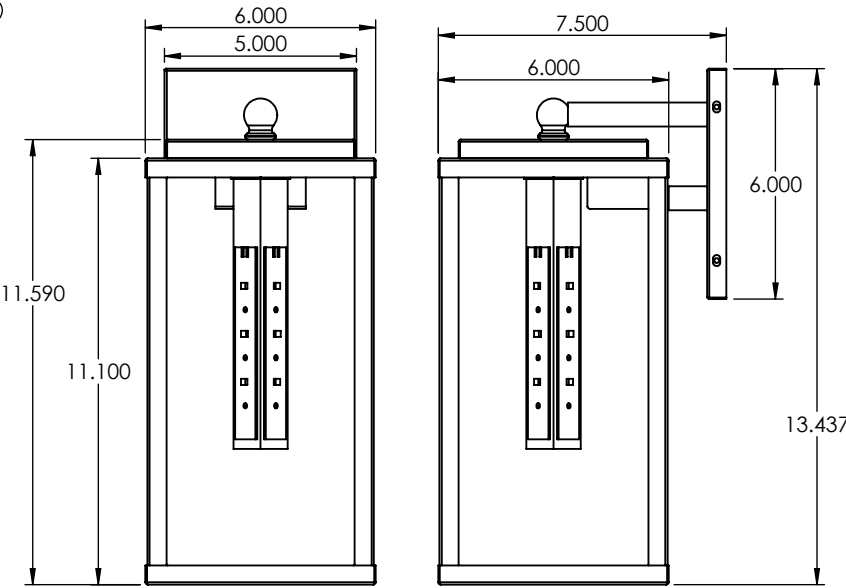
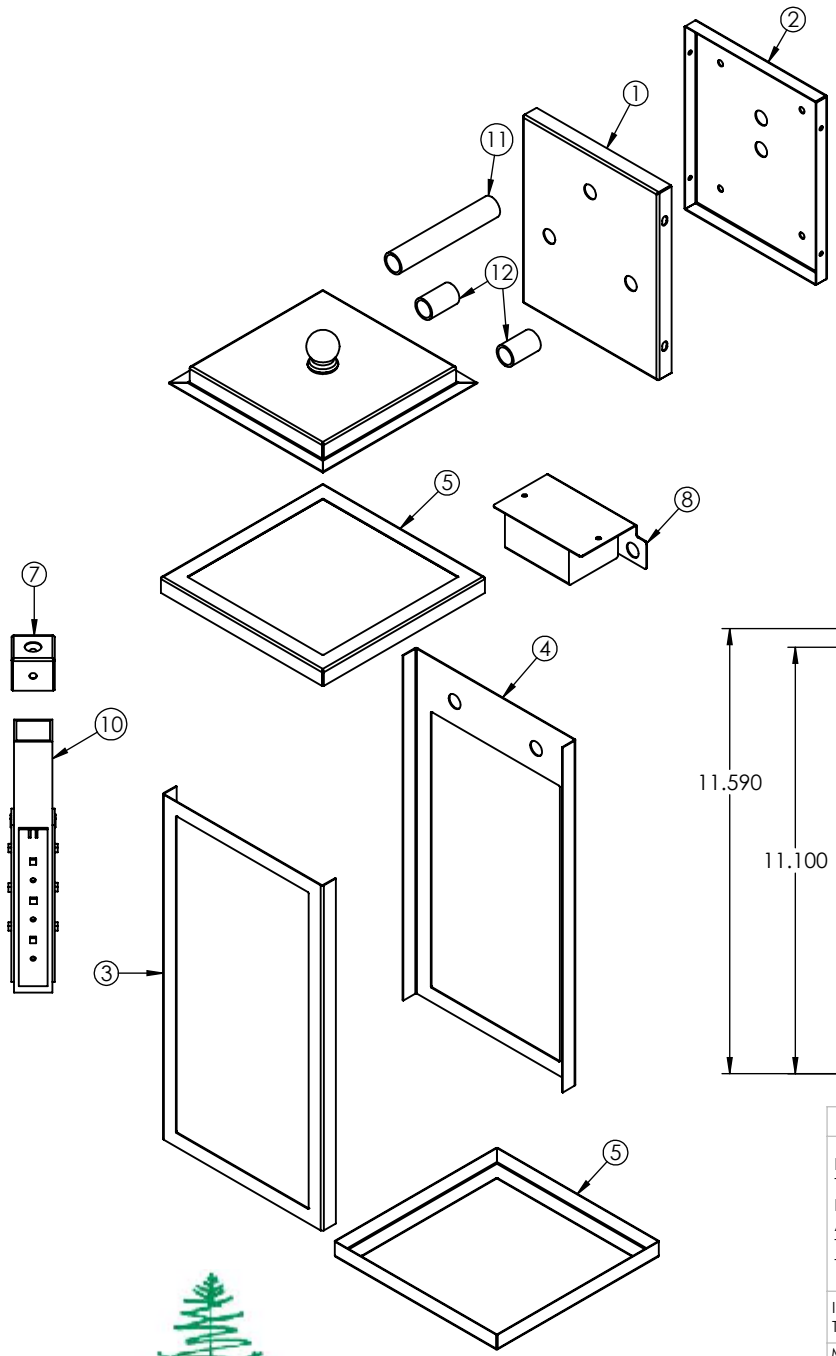

ALL BEND RADIUS .030"

UNLESS OTHERWISE SPECIFIED:

DIMENSIONS ARE IN INCHES  
 TOLERANCES:  
 FRACTIONAL ± .003  
 ANGULAR: MACH ± .01 BEND ±  
 TWO PLACE DECIMAL ±  
 THREE PLACE DECIMAL ±.001

INTERPRET GEOMETRIC  
 TOLERANCING PER:

MATERIAL

FINISH

NAME DATE

DRAWN

CHECKED

ENG APPR.

MFG APPR.

Q.A.

COMMENTS:

TITLE:

702106L-MBK-WF-41K-T4

SIZE DWG. NO. REV

**A** TICKET 25109

SCALE: 1:5 WEIGHT: SHEET 1 OF 9

5

4

3

2

1

APPLICATION

DO NOT SCALE DRAWING

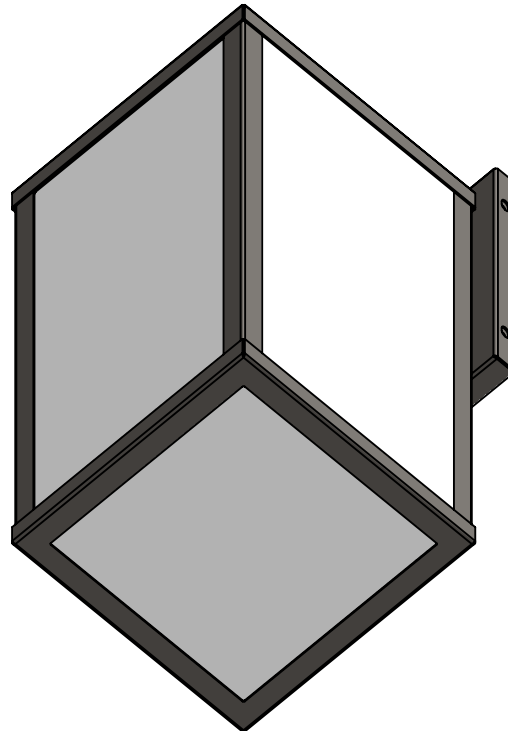
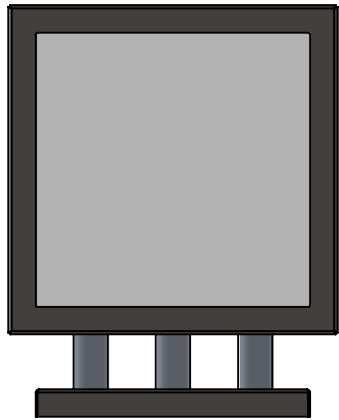
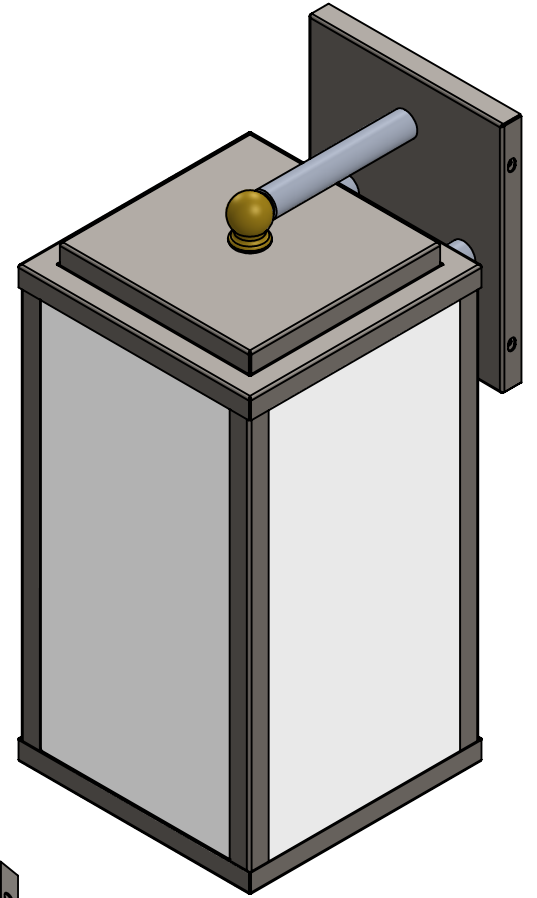
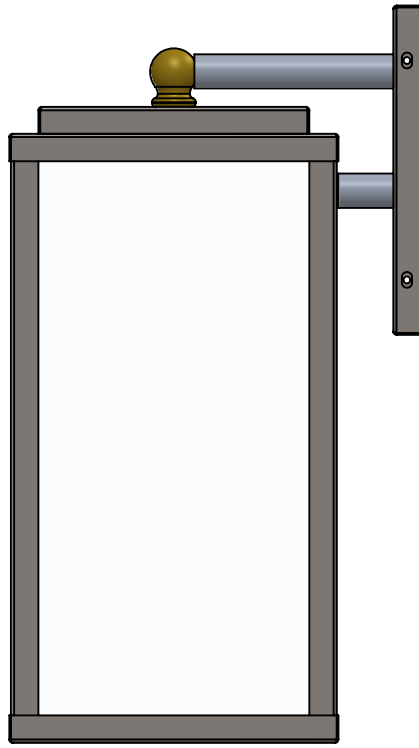
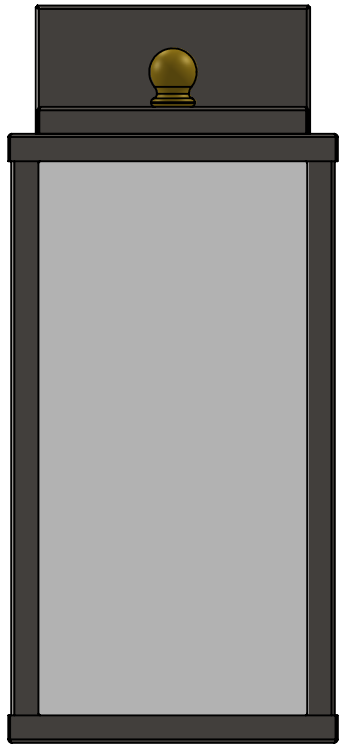

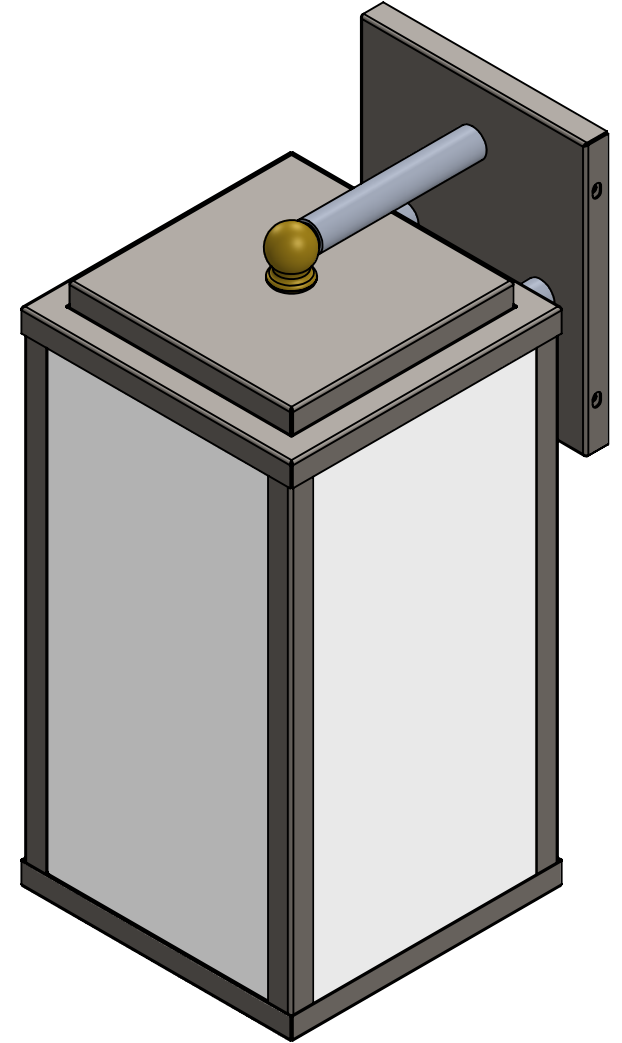
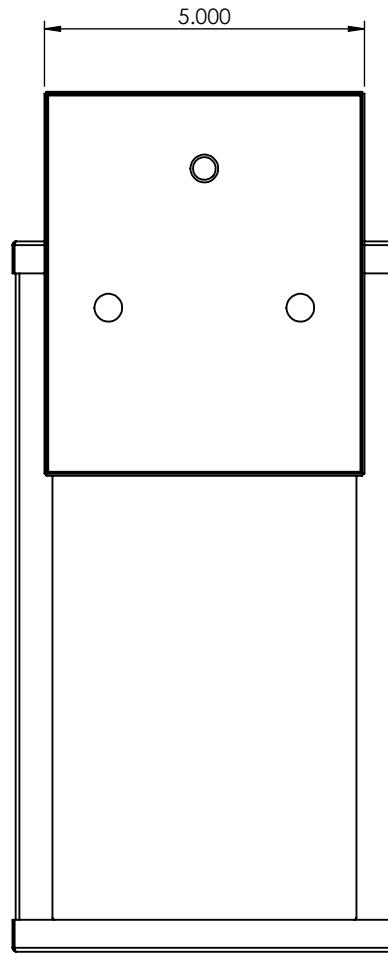
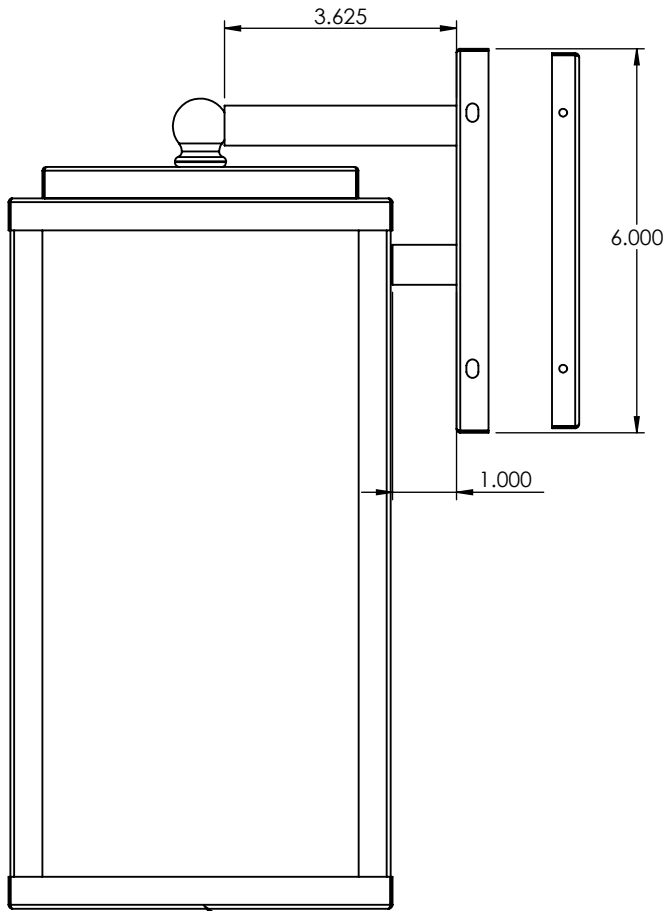

BOTTOM HAS DROP IN LENS OPENNING

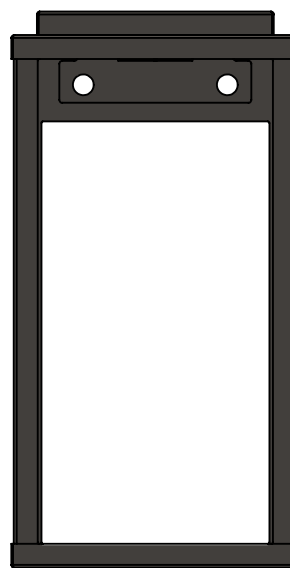
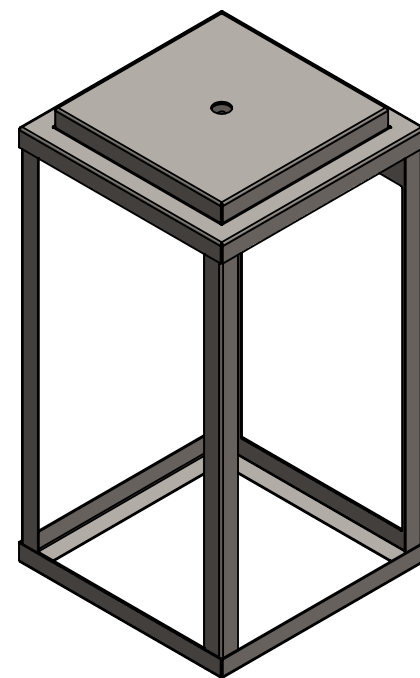
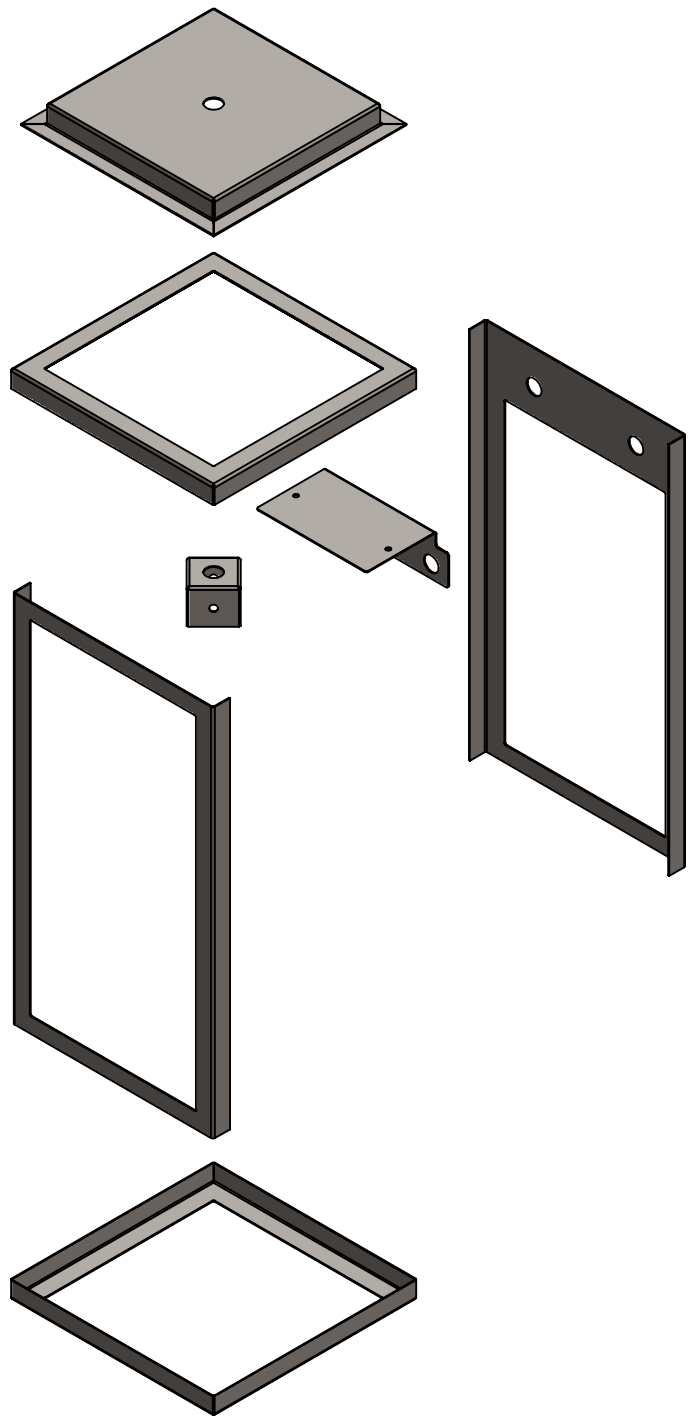

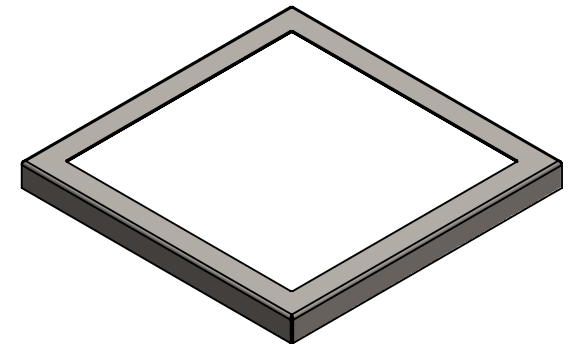
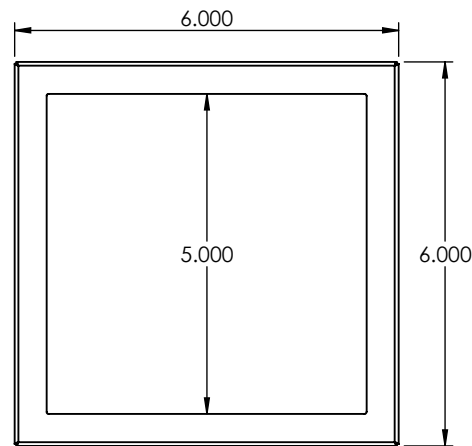
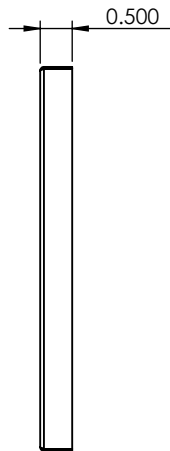
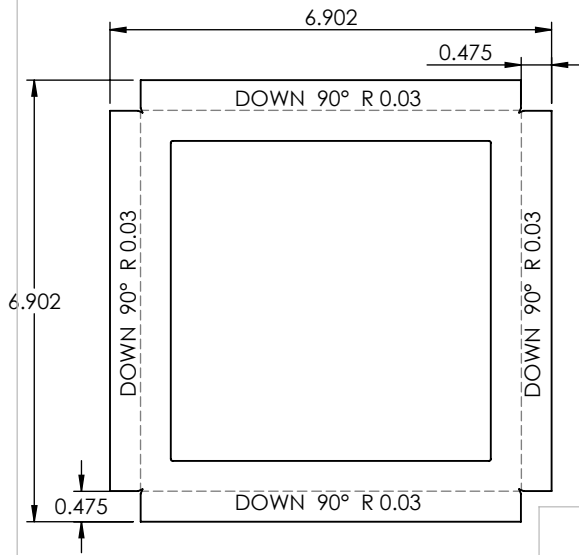
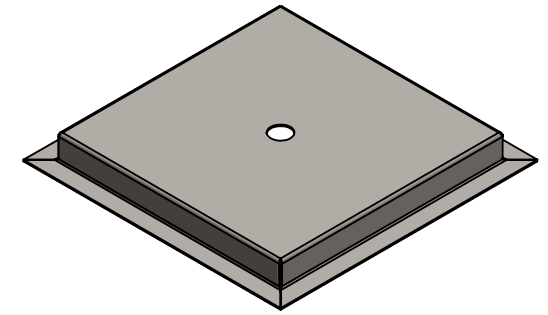
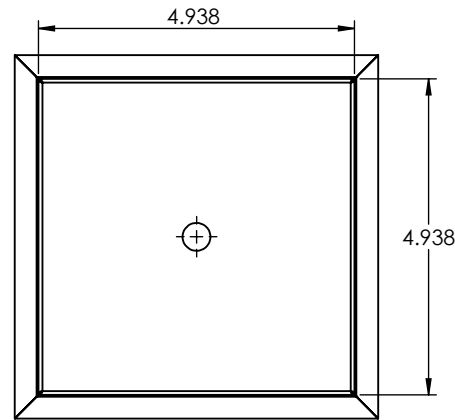
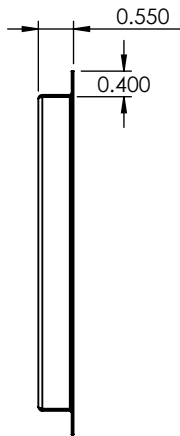
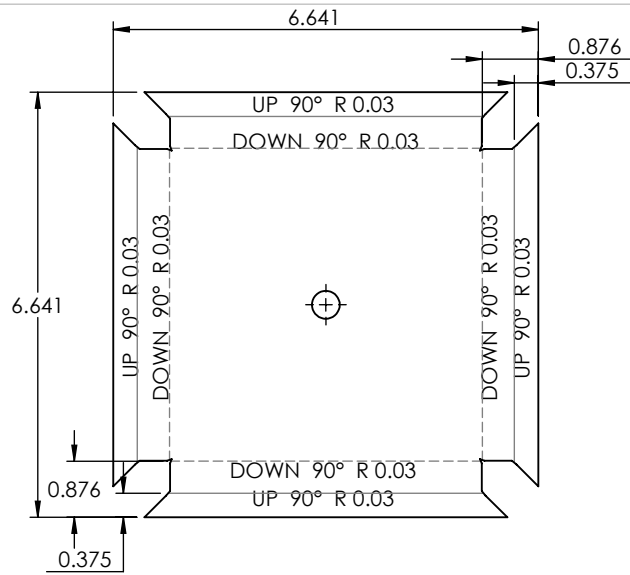

**PROPRIETARY AND CONFIDENTIAL**  
 THE INFORMATION CONTAINED IN THIS DRAWING IS THE SOLE PROPERTY OF <INSERT COMPANY NAME HERE>. ANY REPRODUCTION IN PART OR AS A WHOLE WITHOUT THE WRITTEN PERMISSION OF <INSERT COMPANY NAME HERE> IS PROHIBITED.

		UNLESS OTHERWISE SPECIFIED:		NAME	DATE
		DIMENSIONS ARE IN INCHES	DRAWN		
		TOLERANCES:	CHECKED		
		FRACTIONAL ±	ENG APPR.		
		ANGULAR: MACH ± BEND ±	MFG APPR.		
		TWO PLACE DECIMAL ±	Q.A.		
		THREE PLACE DECIMAL ±	COMMENTS:		
		INTERPRET GEOMETRIC TOLERANCING PER:			
		MATERIAL			
NEXT ASSY	USED ON	FINISH			
APPLICATION		DO NOT SCALE DRAWING			

22 GAUGE		
TITLE:		
702106L-MBK-WF-41K-T4		
SIZE	DWG. NO.	REV
<b>A</b>		
SCALE: 1:3	WEIGHT:	SHEET 5 OF 9

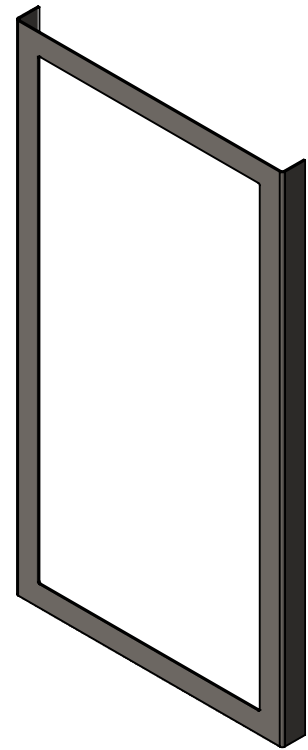
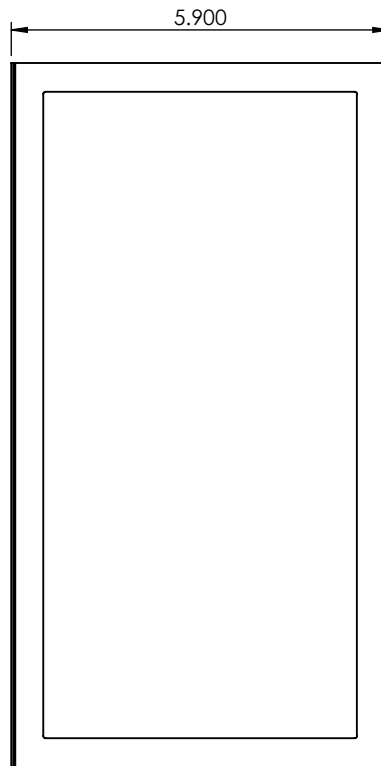
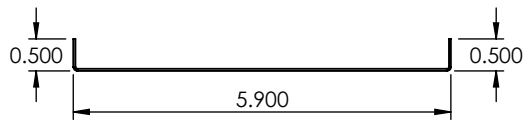
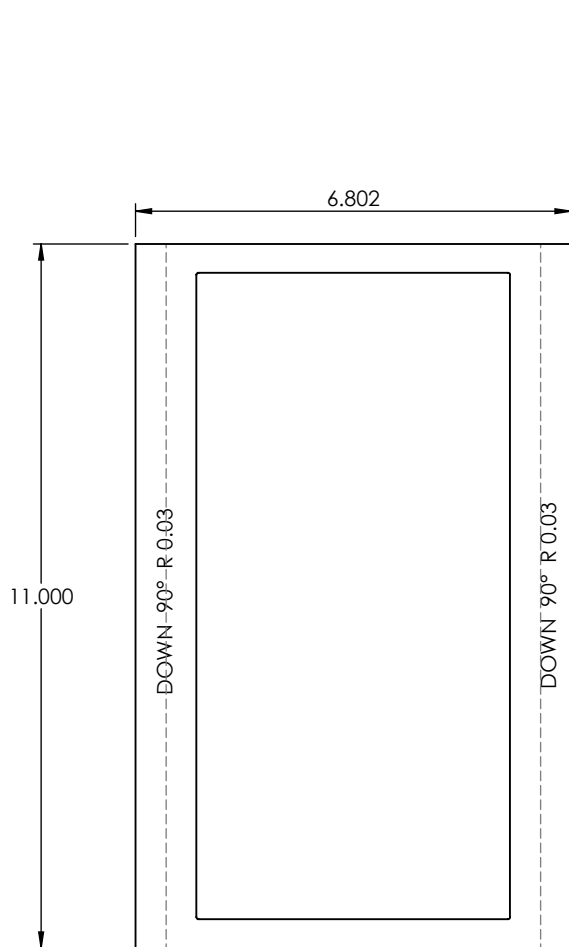

**PROPRIETARY AND CONFIDENTIAL**  
 THE INFORMATION CONTAINED IN THIS DRAWING IS THE SOLE PROPERTY OF <INSERT COMPANY NAME HERE>. ANY REPRODUCTION IN PART OR AS A WHOLE WITHOUT THE WRITTEN PERMISSION OF <INSERT COMPANY NAME HERE> IS PROHIBITED.

		UNLESS OTHERWISE SPECIFIED:		NAME	DATE
		DIMENSIONS ARE IN INCHES	DRAWN		
		TOLERANCES:	CHECKED		
		FRACTIONAL ±	ENG APPR.		
		ANGULAR: MACH ± BEND ±	MFG APPR.		
		TWO PLACE DECIMAL ±	Q.A.		
		THREE PLACE DECIMAL ±	COMMENTS:		
		INTERPRET GEOMETRIC TOLERANCING PER:			
		MATERIAL			
		FINISH			
NEXT ASSY	USED ON				
APPLICATION		DO NOT SCALE DRAWING			

22 GAUGE		
TITLE:		
702106L-MBK-WF-41K-T4		
SIZE	DWG. NO.	REV
<b>A</b>		
SCALE: 1:3	WEIGHT:	SHEET 6 OF 9

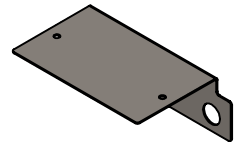
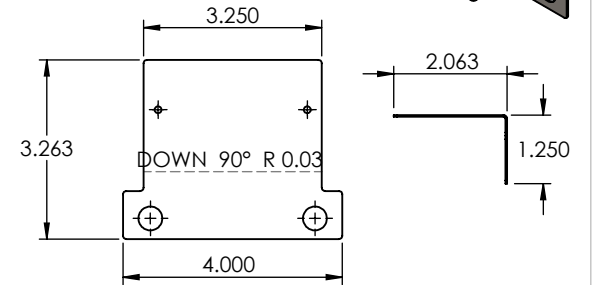
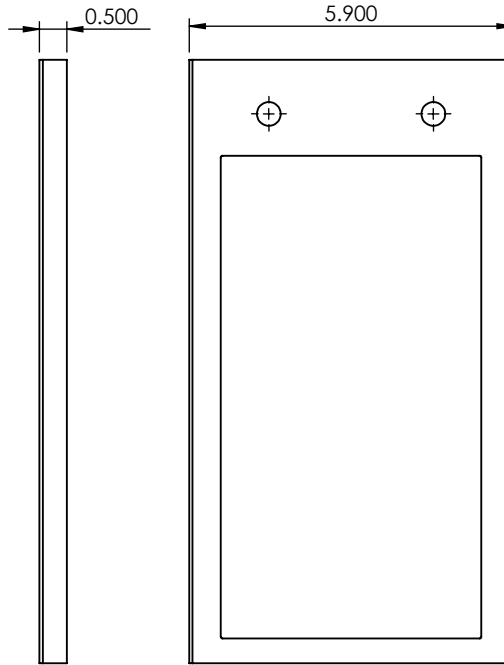
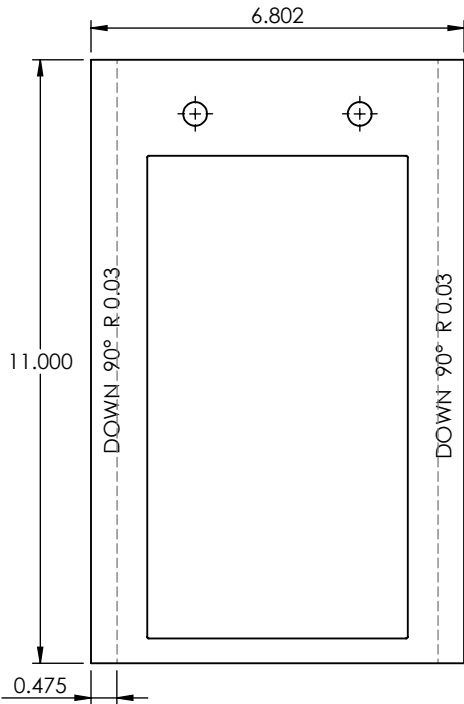
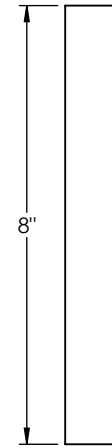
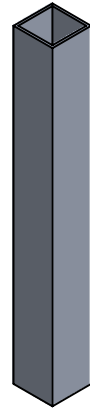
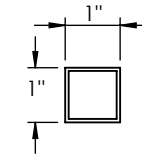
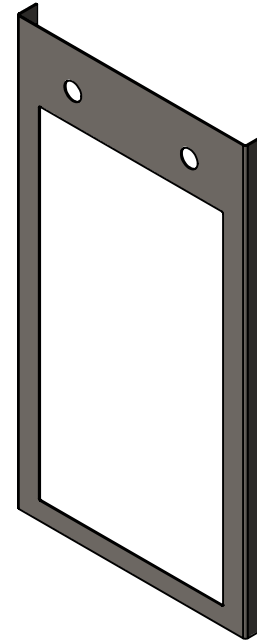
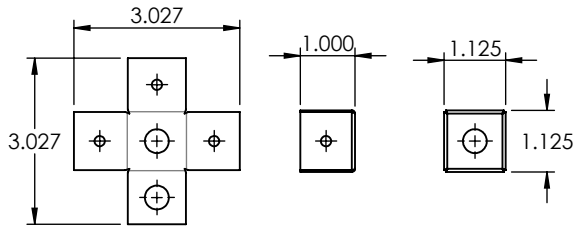

**PROPRIETARY AND CONFIDENTIAL**  
 THE INFORMATION CONTAINED IN THIS DRAWING IS THE SOLE PROPERTY OF <INSERT COMPANY NAME HERE>. ANY REPRODUCTION IN PART OR AS A WHOLE WITHOUT THE WRITTEN PERMISSION OF <INSERT COMPANY NAME HERE> IS PROHIBITED.

		UNLESS OTHERWISE SPECIFIED:	NAME	DATE
		DIMENSIONS ARE IN INCHES	DRAWN	
		TOLERANCES:	CHECKED	
		FRACTIONAL ±	ENG APPR.	
		ANGULAR: MACH ± BEND ±	MFG APPR.	
		TWO PLACE DECIMAL ±	Q.A.	
		THREE PLACE DECIMAL ±	COMMENTS:	
		INTERPRET GEOMETRIC TOLERANCING PER:		
		MATERIAL		
		OLI RUBBER BRONZE POWDERCOAT		
		FINISH		
NEXT ASSY	USED ON			
APPLICATION	DO NOT SCALE DRAWING			

<b>22 GAUGE</b>		
TITLE:		
702106L-MBK-WF-41K-T4		
SIZE	DWG. NO.	REV
<b>A</b>		
SCALE: 1:3.5WEIGHT:		SHEET 7 OF 9

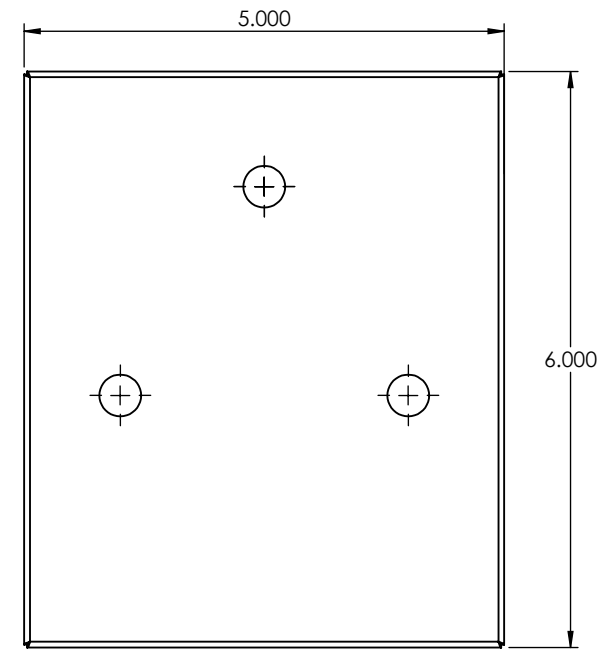
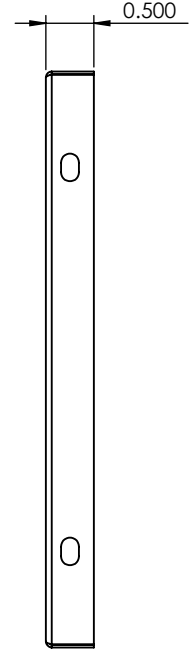
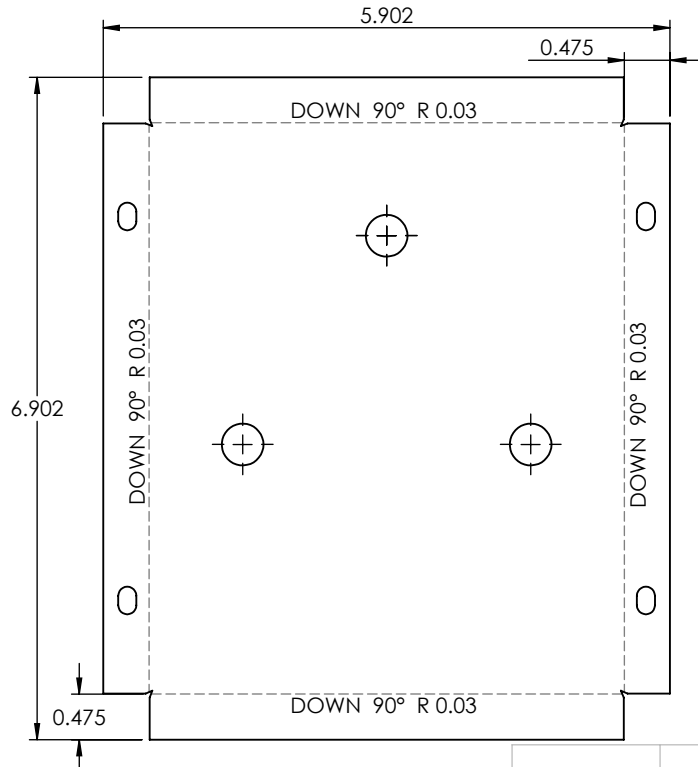
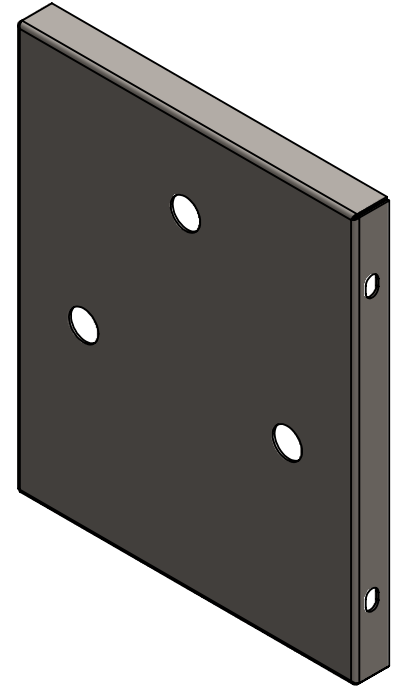
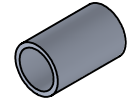
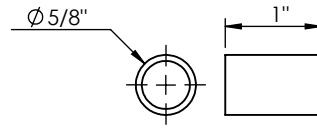
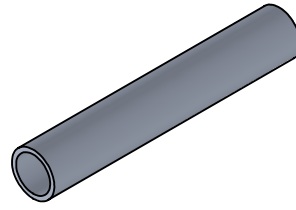
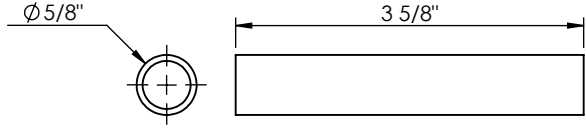

**PROPRIETARY AND CONFIDENTIAL**  
 THE INFORMATION CONTAINED IN THIS DRAWING IS THE SOLE PROPERTY OF <INSERT COMPANY NAME HERE>. ANY REPRODUCTION IN PART OR AS A WHOLE WITHOUT THE WRITTEN PERMISSION OF <INSERT COMPANY NAME HERE> IS PROHIBITED.

		UNLESS OTHERWISE SPECIFIED:		NAME	DATE
		DIMENSIONS ARE IN INCHES TOLERANCES: FRACTIONAL ± ANGULAR: MACH ± BEND ± TWO PLACE DECIMAL ± THREE PLACE DECIMAL ±		DRAWN	
		INTERPRET GEOMETRIC TOLERANCING PER:		CHECKED	
		MATERIAL		ENG APPR.	
		FINISH		MFG APPR.	
NEXT ASSY		USED ON		Q.A.	
APPLICATION		DO NOT SCALE DRAWING		COMMENTS:	

22 GAUGE		
TITLE:  702106L-MBK-WF-41K-T4		
SIZE <b>A</b>	DWG. NO.	REV
SCALE: 1:2	WEIGHT:	SHEET 8 OF 9



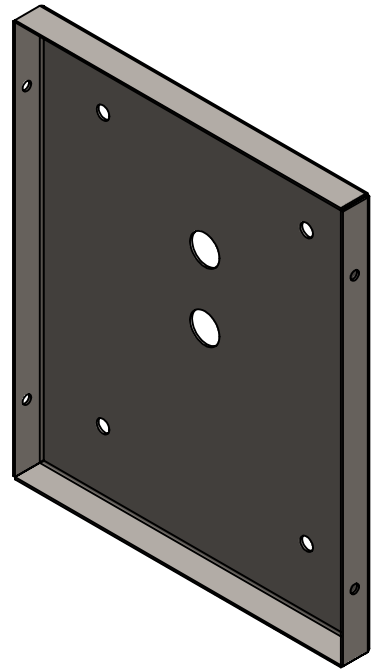
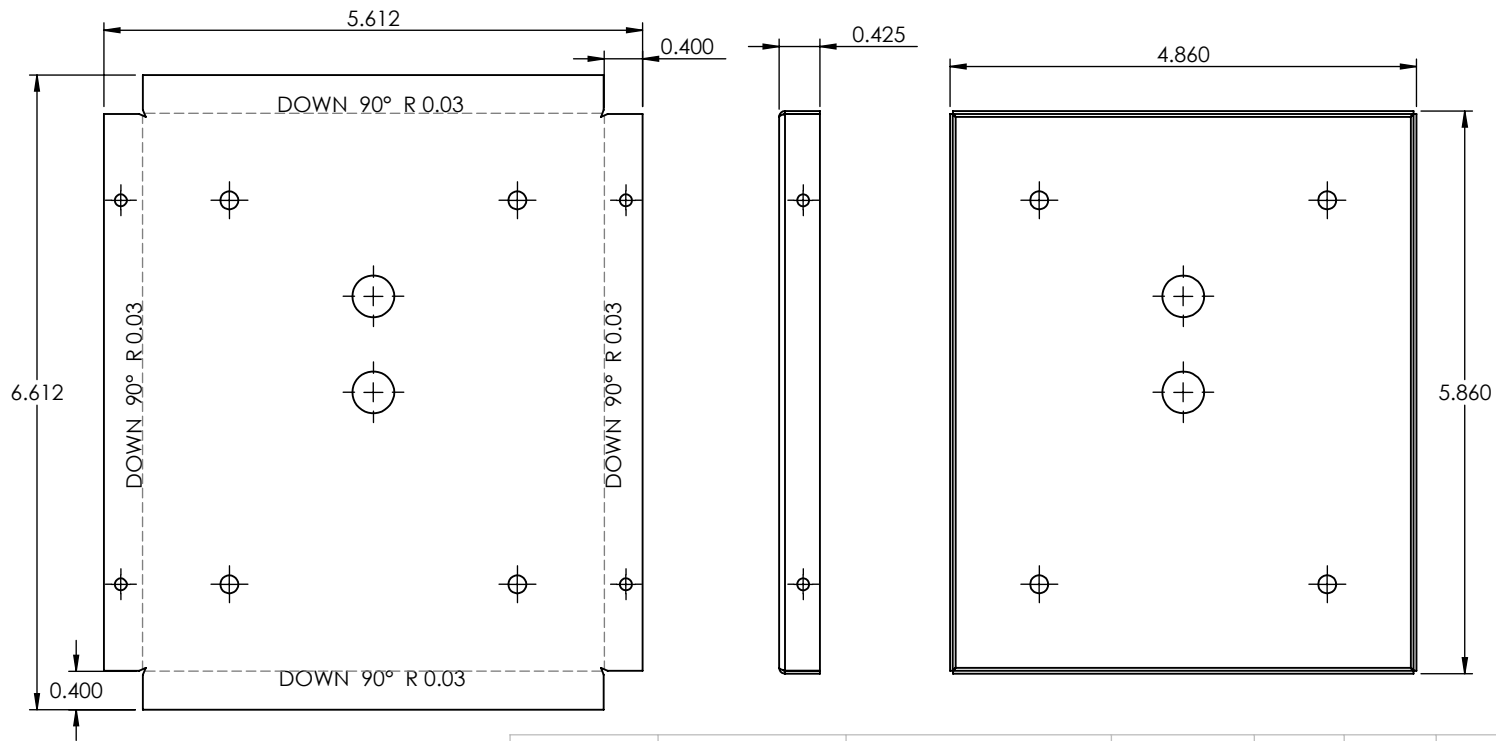

**PROPRIETARY AND CONFIDENTIAL**  
 THE INFORMATION CONTAINED IN THIS DRAWING IS THE SOLE PROPERTY OF <INSERT COMPANY NAME HERE>. ANY REPRODUCTION IN PART OR AS A WHOLE WITHOUT THE WRITTEN PERMISSION OF <INSERT COMPANY NAME HERE> IS PROHIBITED.

		UNLESS OTHERWISE SPECIFIED:		NAME	DATE	22 GAUGE	
		DIMENSIONS ARE IN INCHES TOLERANCES: FRACTIONAL ± ANGULAR: MACH ± BEND ± TWO PLACE DECIMAL ± THREE PLACE DECIMAL ±		DRAWN			
		INTERPRET GEOMETRIC TOLERANCING PER:		CHECKED		SIZE DWG. NO. REV	
		MATERIAL		ENG APPR.			
		FINISH		MFG APPR.		SCALE: 1:3 WEIGHT: SHEET 9 OF 9	
NEXT ASSY	USED ON			Q.A.			
APPLICATION		DO NOT SCALE DRAWING		COMMENTS:			