

ALL BEND RADIUS .030"

UNLESS OTHERWISE SPECIFIED:

DIMENSIONS ARE IN INCHES
 TOLERANCES:
 FRACTIONAL ± .003
 ANGULAR: MACH ± .01 BEND ±
 TWO PLACE DECIMAL ±
 THREE PLACE DECIMAL ±.001

INTERPRET GEOMETRIC
 TOLERANCING PER:

MATERIAL

FINISH

APPLICATION

DO NOT SCALE DRAWING

NAME DATE

DRAWN
 CHECKED
 ENG APPR.
 MFG APPR.

Q.A.

COMMENTS:

FIXTURE HEAD

TITLE:

FLO-P-25"-TPARM-16LS-MBK-WF-WET-30

SIZE DWG. NO. REV

A TICKET 25134

SCALE: 1:9 WEIGHT: SHEET 1 OF 11

5

4

3

2

1

ITEM NO.	PART NUMBER	DESCRIPTION	QTY.	CUT
1	FLO-P-25"-TPARM-16LS-MBK-WF-WET-30K-TOP CAP	22 GAUGE	1	
2	FLO-P-25"-TPARM-16LS-MBK-WF-WET-30K-FRAME TOP BEND	22 GAUGE	6	
3	FLO-P-25"-TPARM-16LS-MBK-WF-WET-30K-FRAME TABS	22 GAUGE	6	
4	FLO-P-25"-TPARM-16LS-MBK-WF-WET-30K-DOOR	22 GAUGE	1	
5	FLO-P-25"-TPARM-16LS-MBK-WF-WET-30K-FRAME BOTTOM BEND	22 GAUGE	6	
6	FLO-P-25"-TPARM-16LS-MBK-WF-WET-30K-BOTTOM CAP	22 GAUGE	1	
7	FLO-P-25"-TPARM-16LS-MBK-WF-WET-30K-BRACKET TABS	22 GAUGE	2	
8	FLO-P-25"-TPARM-16LS-MBK-WF-WET-30K-LED BRACKET	22 GAUGE	1	
9	FLO-P-25"-TPARM-16LS-MBK-WF-WET-30K-BOTTOM TAB	22 GAUGE	6	
10	FLO-P-25"-TPARM-16LS-MBK-WF-WET-30K-ACRYLIC	ACRYLIC	6	
11	FLO-P-25"-TPARM-16LS-MBK-WF-WET-30K-0.500" ROUND TUBE	0.500" ROUND TUBE	1	
12	BRASS HALF BALL	1" HALF BRASS BALL	1	
13	Espen VEL19070MVH-1	DRIVER	1	
14	Alttailed_PN1011_RevB	LED	4	

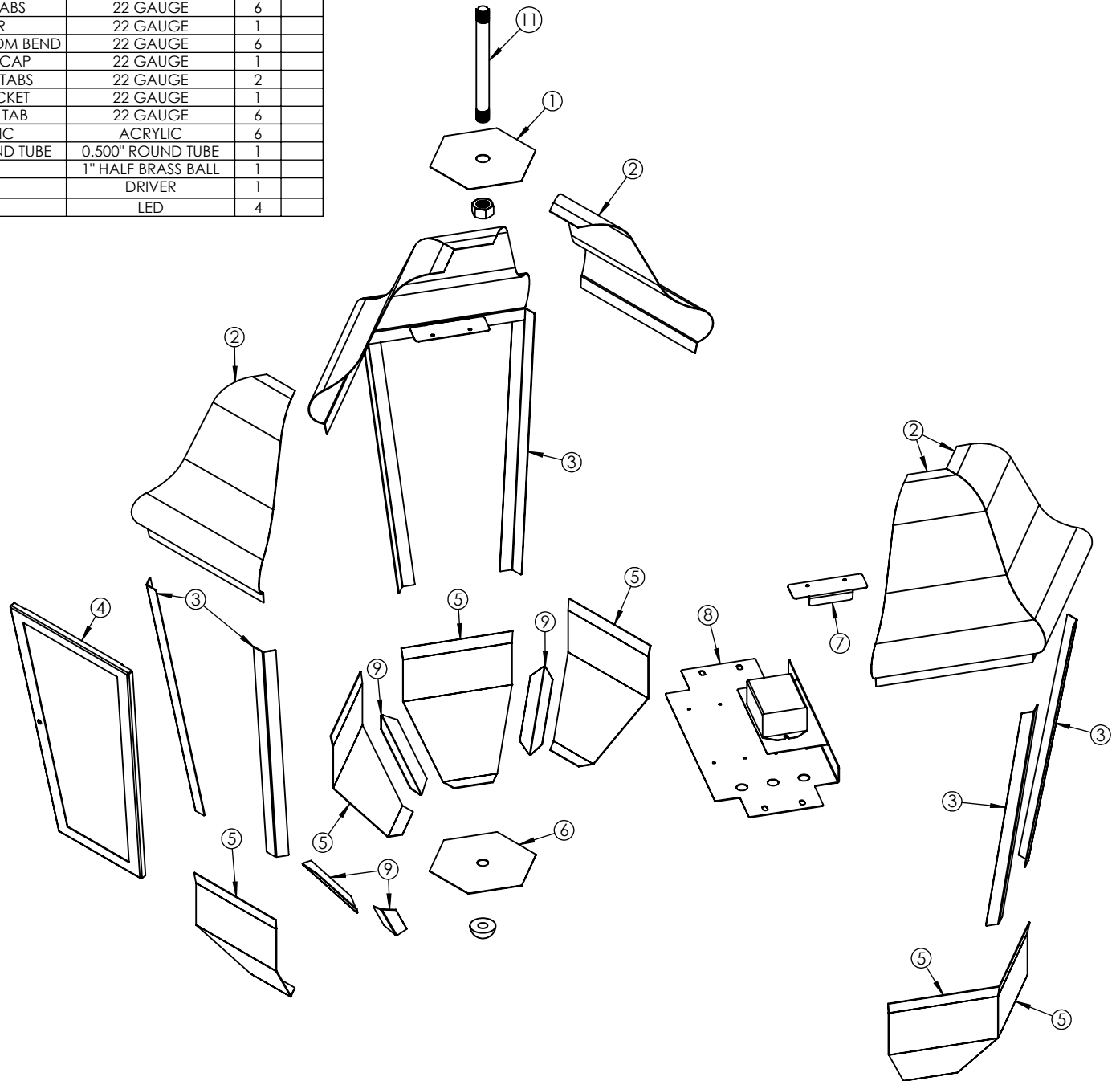

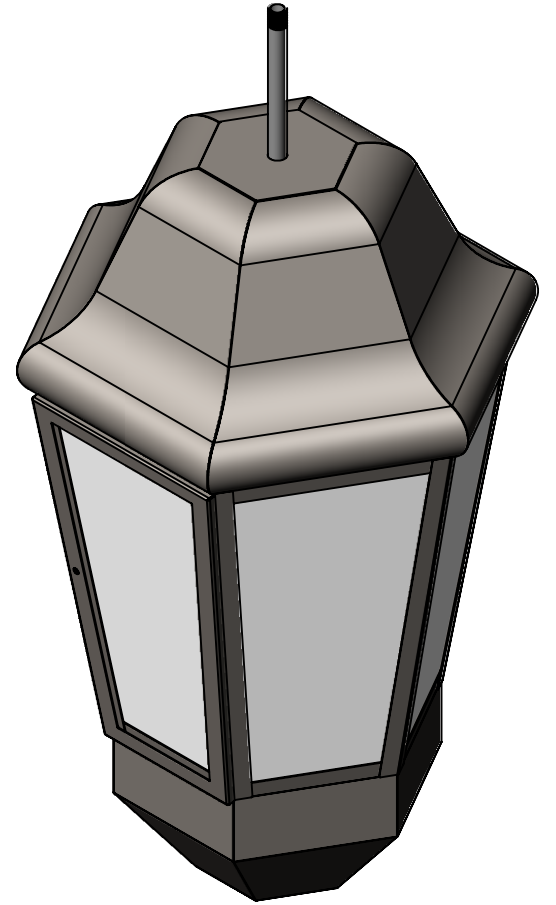
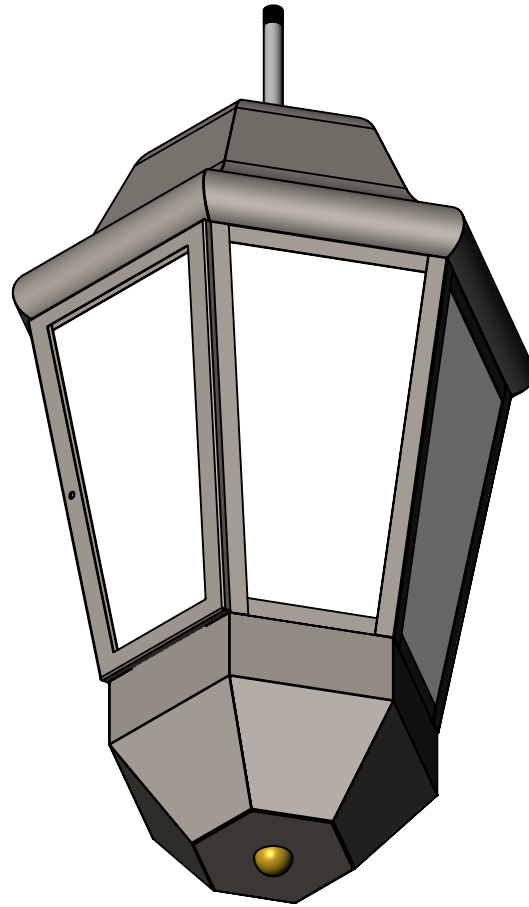
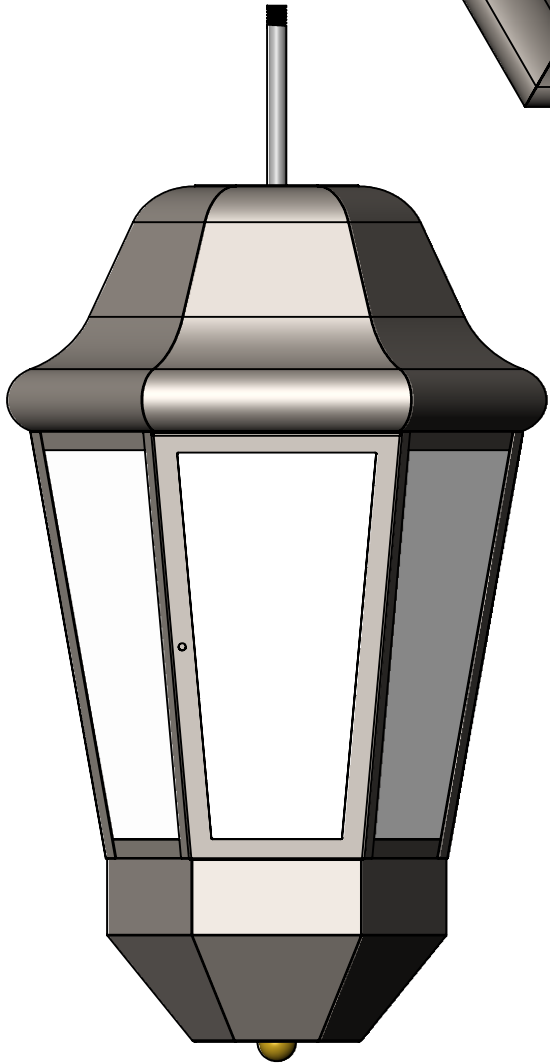
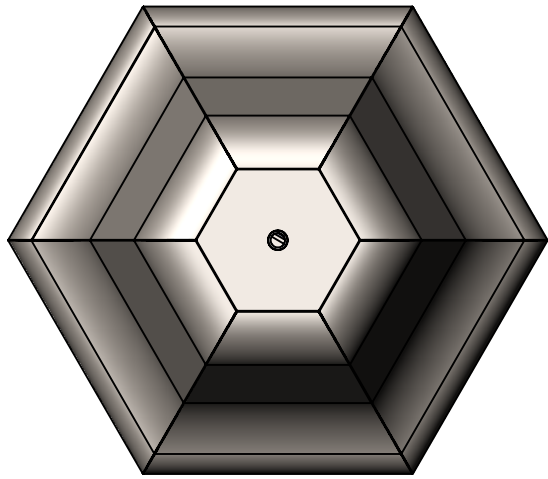

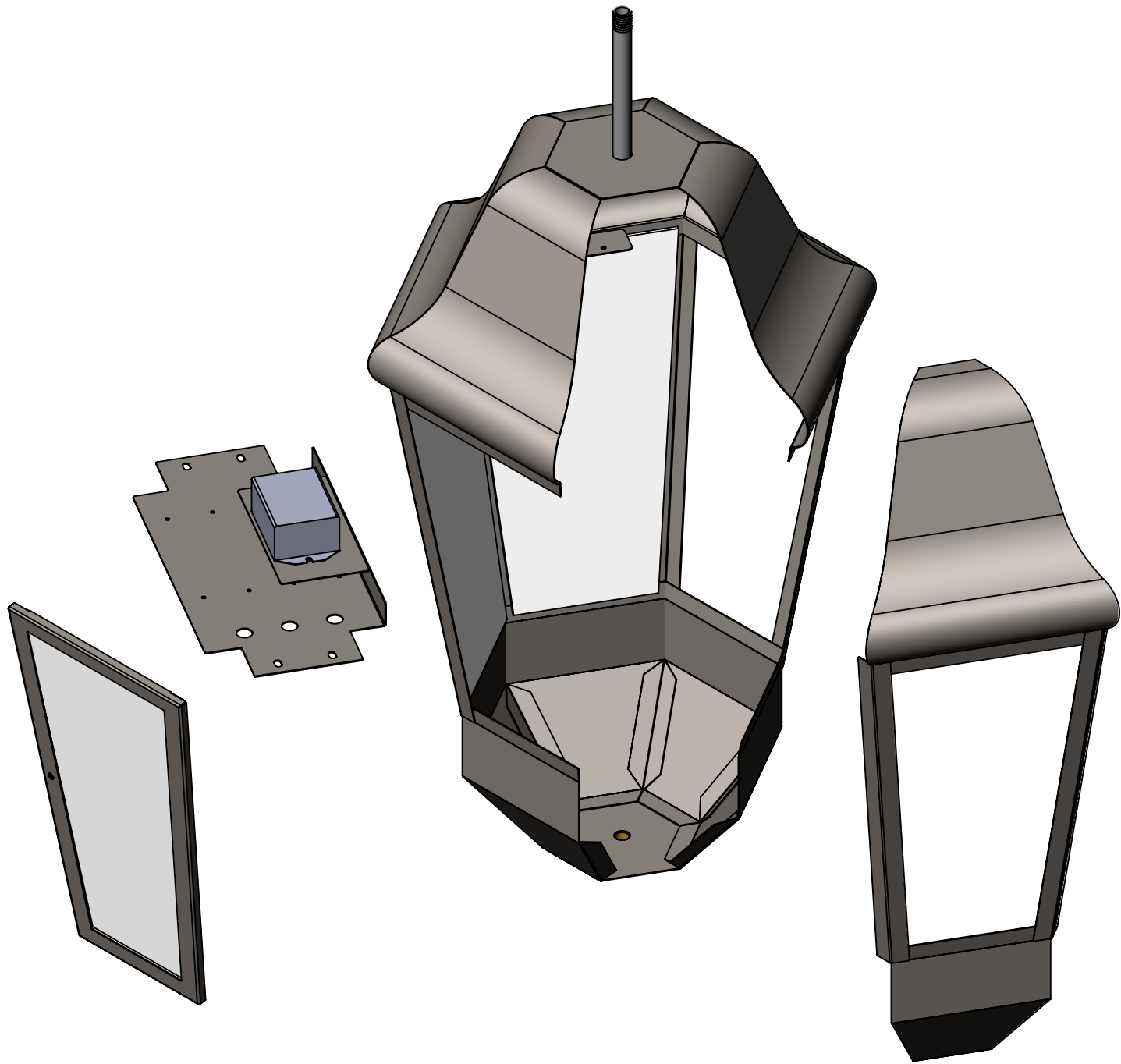

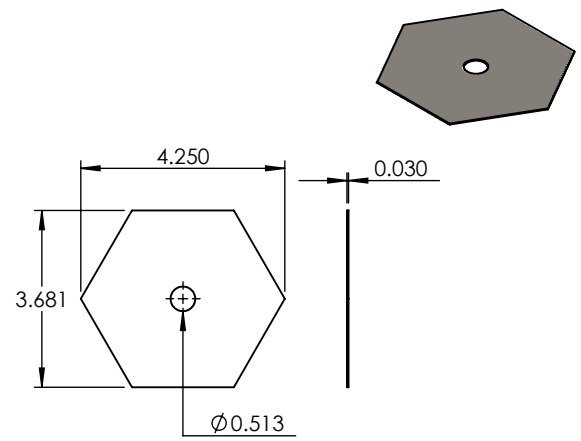
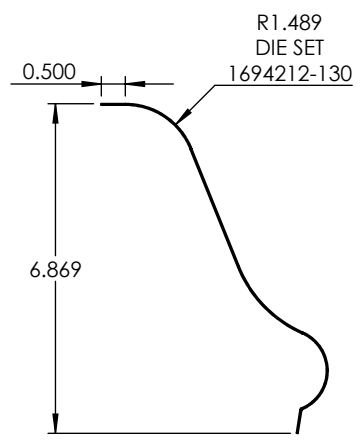
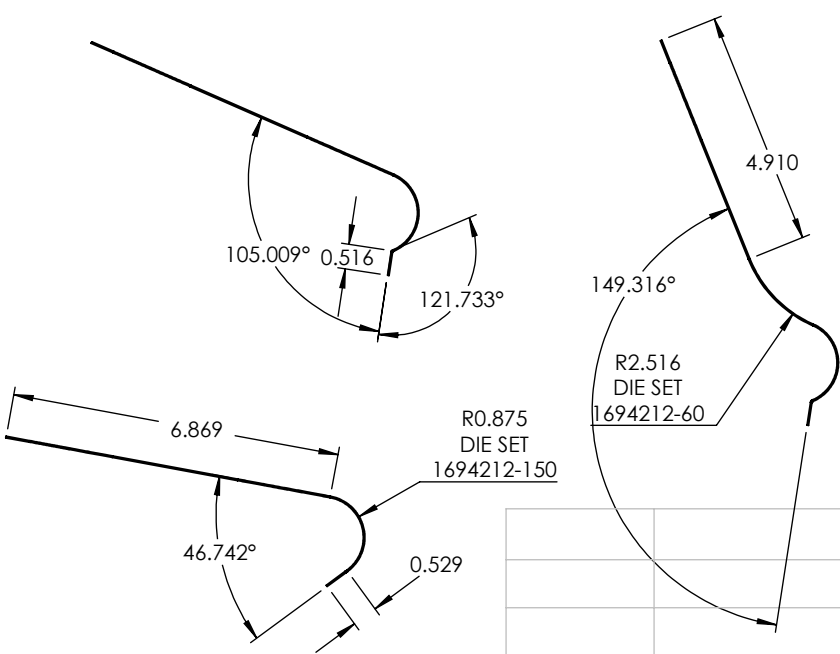
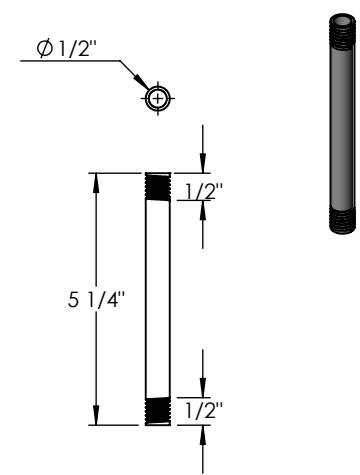
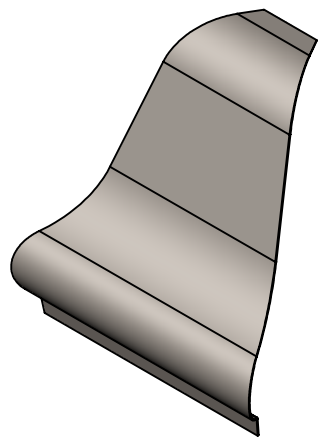
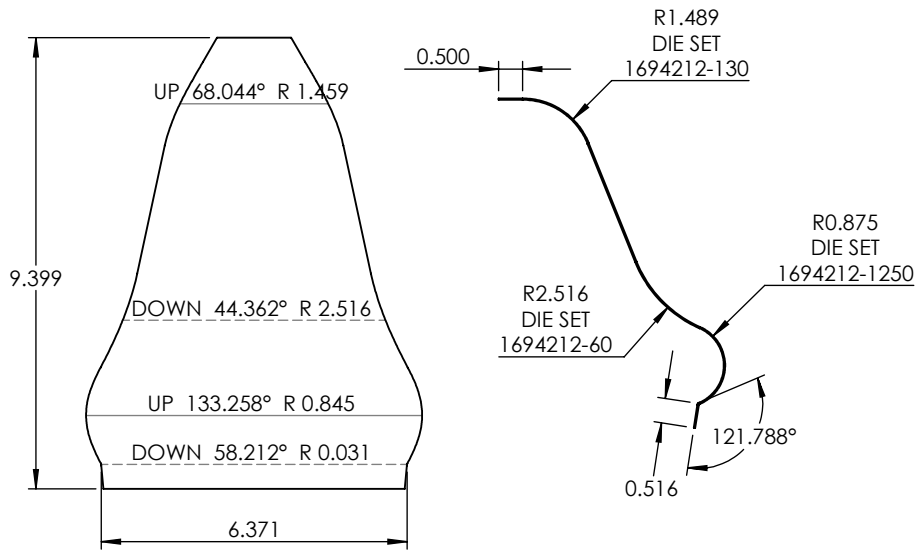

PROPRIETARY AND CONFIDENTIAL
 THE INFORMATION CONTAINED IN THIS DRAWING IS THE SOLE PROPERTY OF <INSERT COMPANY NAME HERE>. ANY REPRODUCTION IN PART OR AS A WHOLE WITHOUT THE WRITTEN PERMISSION OF <INSERT COMPANY NAME HERE> IS PROHIBITED.

		UNLESS OTHERWISE SPECIFIED:	NAME	DATE
		DIMENSIONS ARE IN INCHES	DRAWN	
		TOLERANCES:	CHECKED	
		FRACTIONAL ±	ENG APPR.	
		ANGULAR: MACH ± BEND ±	MFG APPR.	
		TWO PLACE DECIMAL ±	Q.A.	
		THREE PLACE DECIMAL ±	COMMENTS:	
		INTERPRET GEOMETRIC TOLERANCING PER:		
		MATERIAL		
		FINISH		
NEXT ASSY	USED ON			
APPLICATION	DO NOT SCALE DRAWING			

22 GAUGE		
TITLE:		
FLO-P-25"-TPARM-16LS-MBK-WF-WET-30K		
SIZE	DWG. NO.	REV
A		
SCALE: 1:4	WEIGHT:	SHEET 5 OF 11

5

4

3

2

1

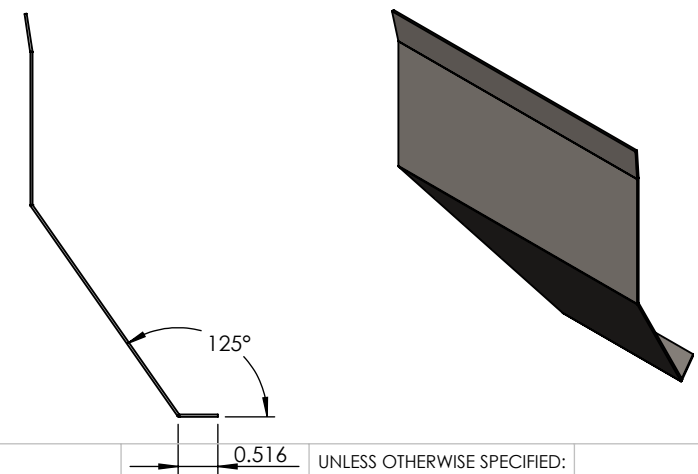
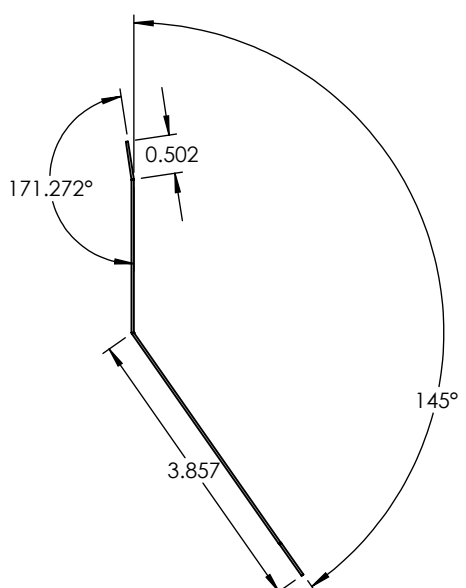
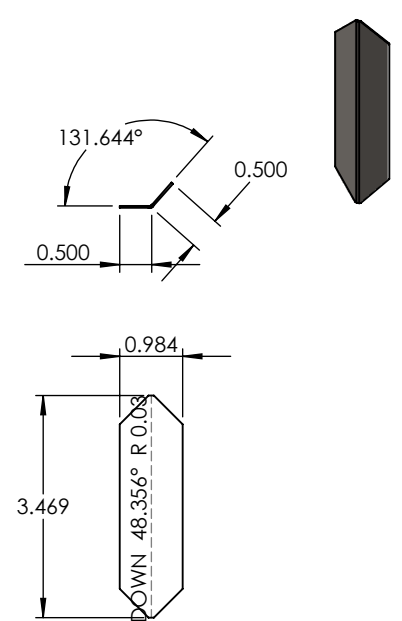
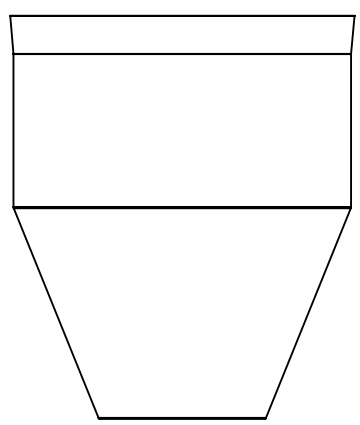
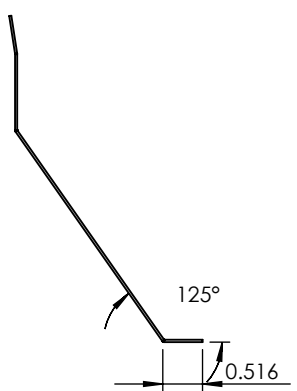
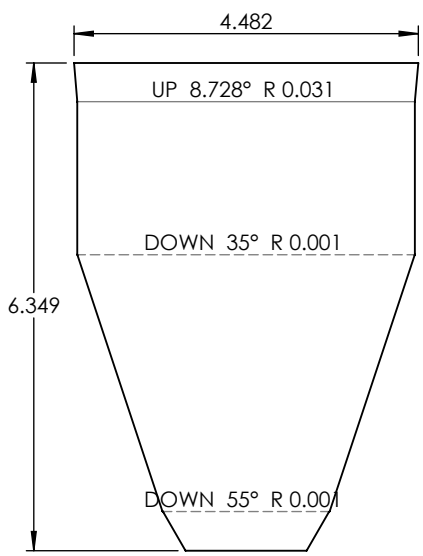

PROPRIETARY AND CONFIDENTIAL
 THE INFORMATION CONTAINED IN THIS DRAWING IS THE SOLE PROPERTY OF <INSERT COMPANY NAME HERE>. ANY REPRODUCTION IN PART OR AS A WHOLE WITHOUT THE WRITTEN PERMISSION OF <INSERT COMPANY NAME HERE> IS PROHIBITED.

		UNLESS OTHERWISE SPECIFIED:	NAME	DATE
		DIMENSIONS ARE IN INCHES	DRAWN	
		TOLERANCES:	CHECKED	
		FRACTIONAL ±	ENG APPR.	
		ANGULAR: MACH ± BEND ±	MFG APPR.	
		TWO PLACE DECIMAL ±	Q.A.	
		THREE PLACE DECIMAL ±	COMMENTS:	
		INTERPRET GEOMETRIC TOLERANCING PER:		
		MATERIAL		
NEXT ASSY	USED ON	FINISH		
APPLICATION		DO NOT SCALE DRAWING		

22 GAUGE		
TITLE:		
FLO-P-25"-TPARM-16LS-MBK-WF-WET-30K		
SIZE	DWG. NO.	REV
A		
SCALE: 1:2.5	WEIGHT:	SHEET 6 OF 11

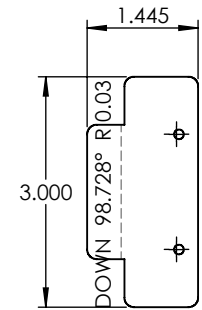
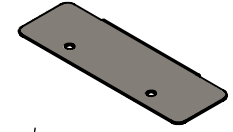
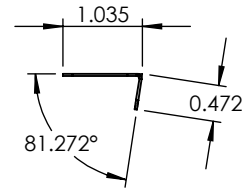
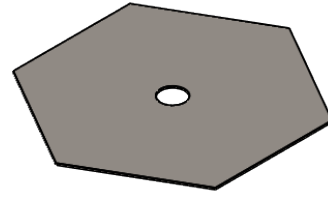
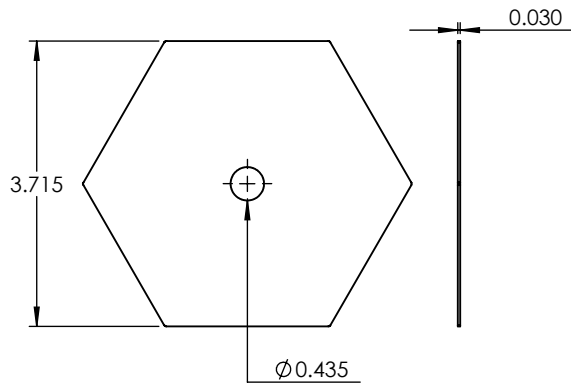
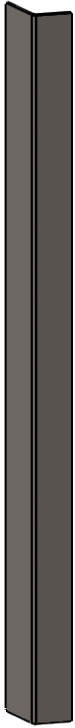
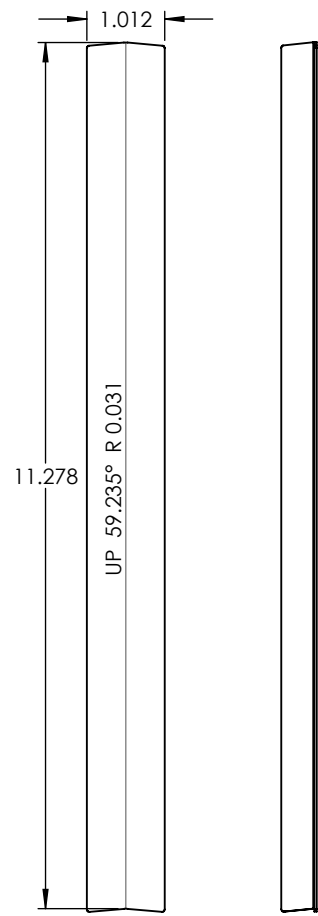
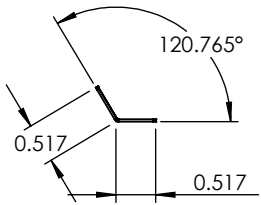

PROPRIETARY AND CONFIDENTIAL
 THE INFORMATION CONTAINED IN THIS DRAWING IS THE SOLE PROPERTY OF <INSERT COMPANY NAME HERE>. ANY REPRODUCTION IN PART OR AS A WHOLE WITHOUT THE WRITTEN PERMISSION OF <INSERT COMPANY NAME HERE> IS PROHIBITED.

		UNLESS OTHERWISE SPECIFIED:	NAME	DATE
		DIMENSIONS ARE IN INCHES TOLERANCES: FRACTIONAL ± ANGULAR: MACH ± BEND ± TWO PLACE DECIMAL ± THREE PLACE DECIMAL ±	DRAWN	
		INTERPRET GEOMETRIC TOLERANCING PER:	CHECKED	
		MATERIAL	ENG APPR.	
		FINISH	MFG APPR.	
NEXT ASSY	USED ON		Q.A.	
			COMMENTS:	
APPLICATION		DO NOT SCALE DRAWING		

22 GAUGE		
TITLE:		
FLO-P-25"-TPARM-16LS-MBK-WF-WET-30K		
SIZE	DWG. NO.	REV
A		
SCALE: 1:2.5WEIGHT:		SHEET 7 OF 11

5

4

3

2

1

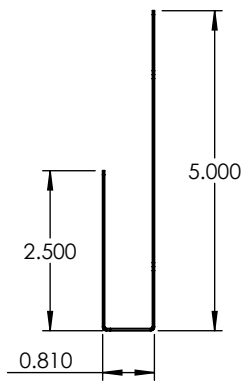
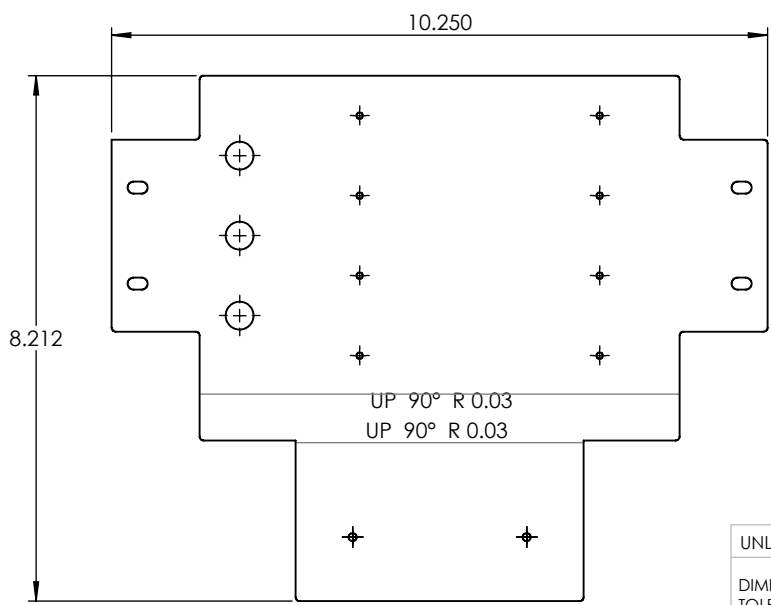
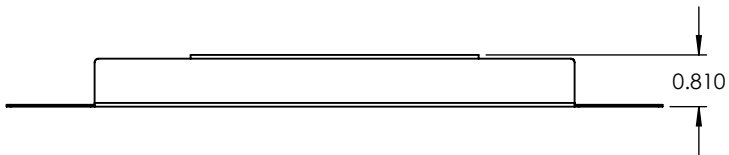
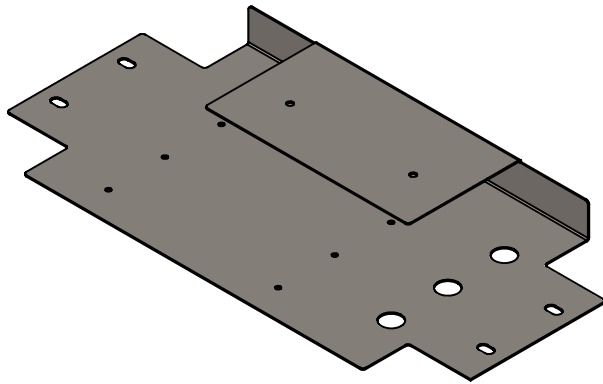

UNLESS OTHERWISE SPECIFIED:		NAME	DATE	22 GAUGE	
DIMENSIONS ARE IN INCHES TOLERANCES: FRACTIONAL ± ANGULAR: MACH ± BEND ± TWO PLACE DECIMAL ± THREE PLACE DECIMAL ±		DRAWN			
INTERPRET GEOMETRIC TOLERANCING PER:		CHECKED		SIZE DWG. NO. REV	
MATERIAL		ENG APPR.			
FINISH		MFG APPR.		COMMENTS:	
APPLICATION		Q.A.			
DO NOT SCALE DRAWING		COMMENTS:			

PROPRIETARY AND CONFIDENTIAL
THE INFORMATION CONTAINED IN THIS DRAWING IS THE SOLE PROPERTY OF <INSERT COMPANY NAME HERE>. ANY REPRODUCTION IN PART OR AS A WHOLE WITHOUT THE WRITTEN PERMISSION OF <INSERT COMPANY NAME HERE> IS PROHIBITED.

NEXT ASSY	USED ON
APPLICATION	

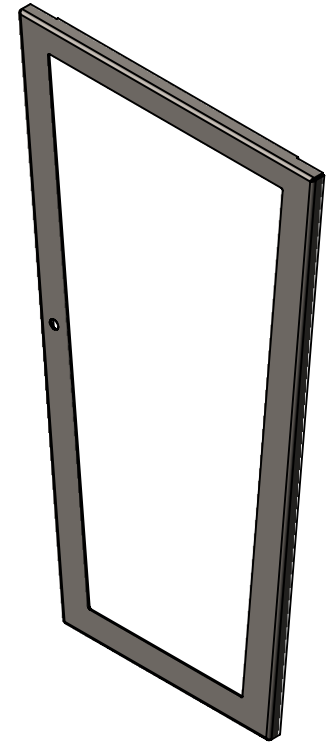
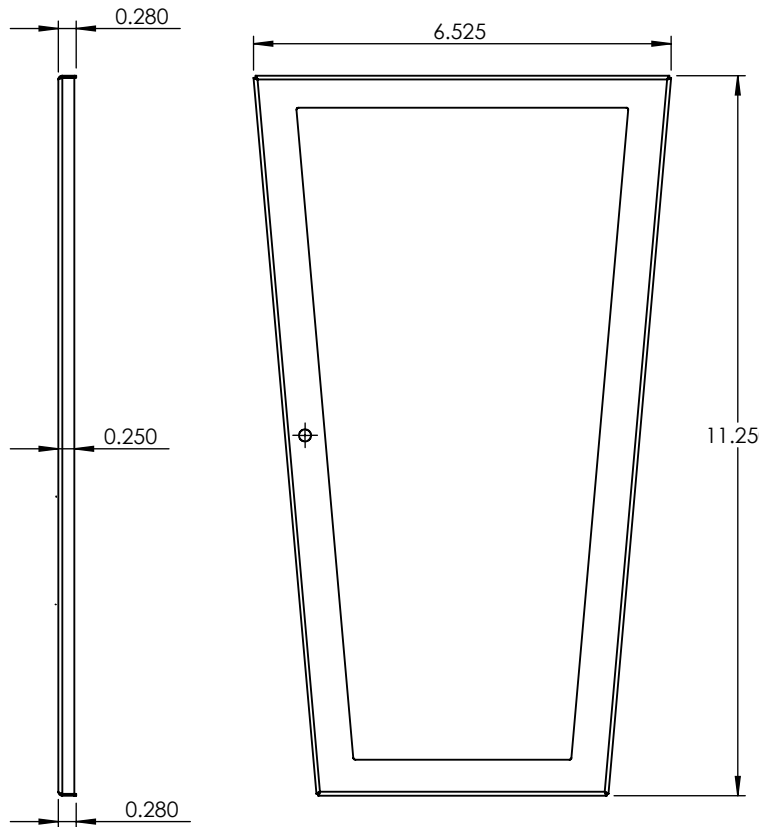

PROPRIETARY AND CONFIDENTIAL
 THE INFORMATION CONTAINED IN THIS DRAWING IS THE SOLE PROPERTY OF <INSERT COMPANY NAME HERE>. ANY REPRODUCTION IN PART OR AS A WHOLE WITHOUT THE WRITTEN PERMISSION OF <INSERT COMPANY NAME HERE> IS PROHIBITED.

		UNLESS OTHERWISE SPECIFIED:	NAME	DATE	22 GAUGE	
		DIMENSIONS ARE IN INCHES TOLERANCES: FRACTIONAL ± ANGULAR: MACH ± BEND ± TWO PLACE DECIMAL ± THREE PLACE DECIMAL ±	DRAWN		TITLE:	
		INTERPRET GEOMETRIC TOLERANCING PER:	CHECKED		FLO-P-25"-TPARM-16LS-MBK-WF-WET-30K	
		MATERIAL	ENG APPR.		SIZE	DWG. NO.
NEXT ASSY	USED ON	FINISH	MFG APPR.		A	REV
APPLICATION		DO NOT SCALE DRAWING	Q.A.		SCALE: 1:3	WEIGHT:
			COMMENTS:			SHEET 9 OF 11

5

4

3

2

1

