

ITEM NO.	PART NUMBER	DESCRIPTION	QTY.	CUT
1	ME-W-24-16W-MN-WF-27K-FRAME	22 GAUGE	1	
2	ME-W-24-16W-MN-WF-27K-FRAME TAB	22 GAUGE	4	
3	ME-W-24-16W-MN-WF-27K-BACKPLATE	22 GAUGE	1	
4	ME-W-24-16W-MN-WF-27K-ACRYLIC	ACRYLIC	1	
5	Espen VEL19070MVH-1	DRIVER	1	
6	AltalED_PN1004RevD	LED	2	

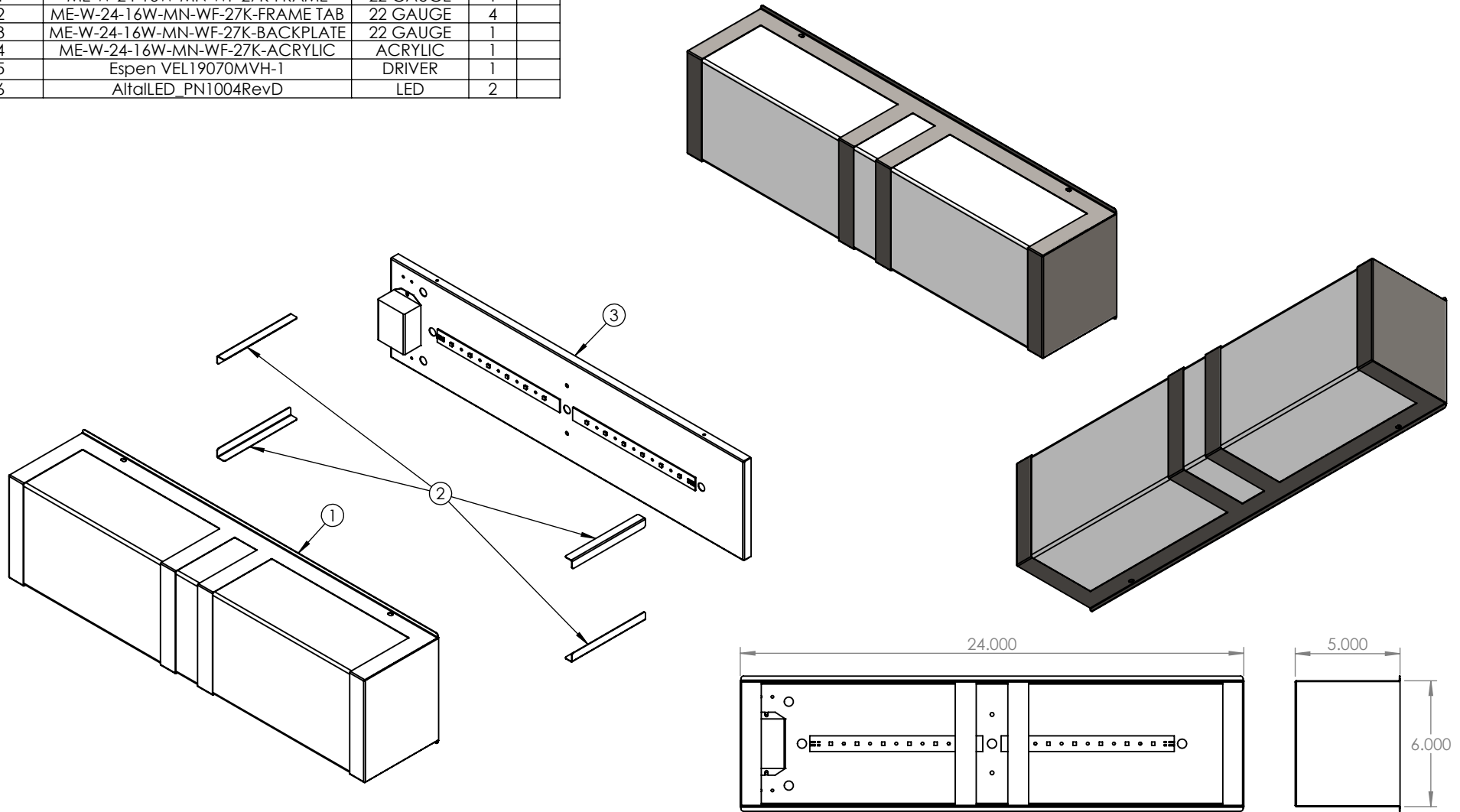

UNLESS OTHERWISE SPECIFIED:		NAME	DATE	TITLE:
DIMENSIONS ARE IN INCHES		DRAWN		
TOLERANCES:		CHECKED		
FRACTIONAL ± .003		ENG APPR.		
ANGULAR: MACH ± .01 BEND ±		MFG APPR.		
TWO PLACE DECIMAL ±		Q.A.		SIZE DWG. NO. REV
THREE PLACE DECIMAL ±.001		COMMENTS:		A TICKET 25139
INTERPRET GEOMETRIC TOLERANCING PER:				SCALE: 1:7 WEIGHT: SHEET 1 OF 4
MATERIAL				
FINISH				
ALL BEND RADIUS .030"				
APPLICATION				
DO NOT SCALE DRAWING				



EVERGREEN LIGHTING

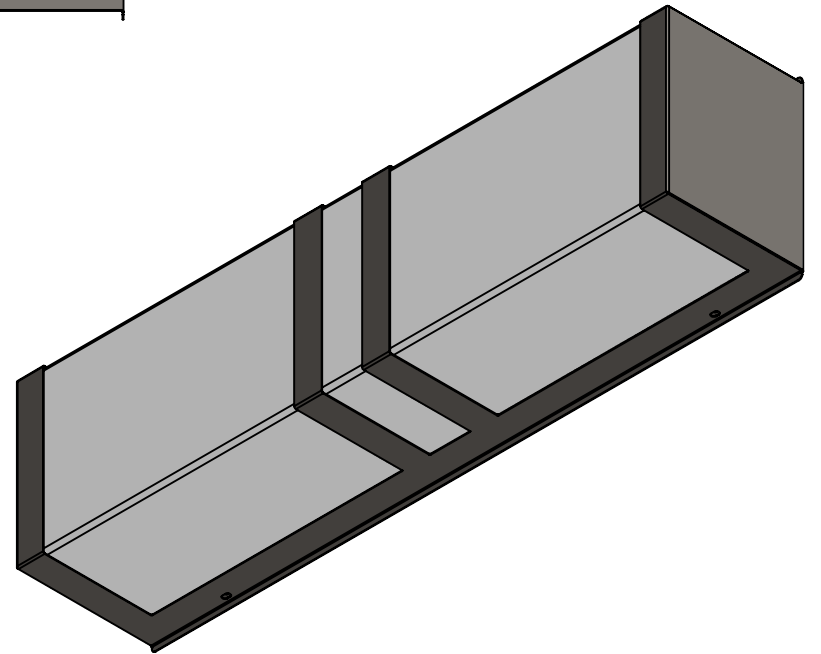
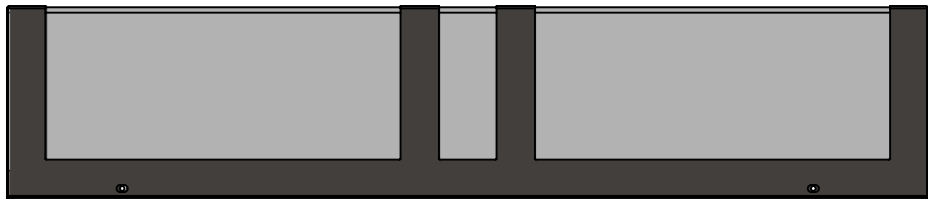
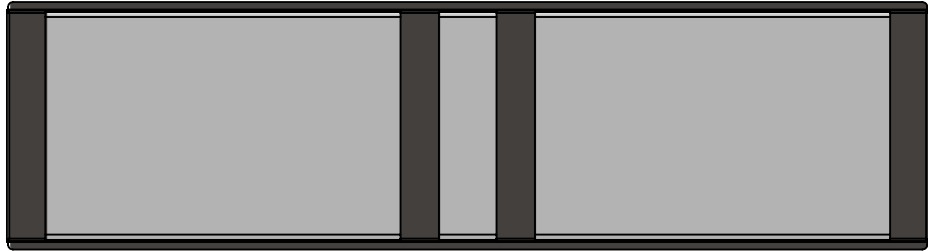
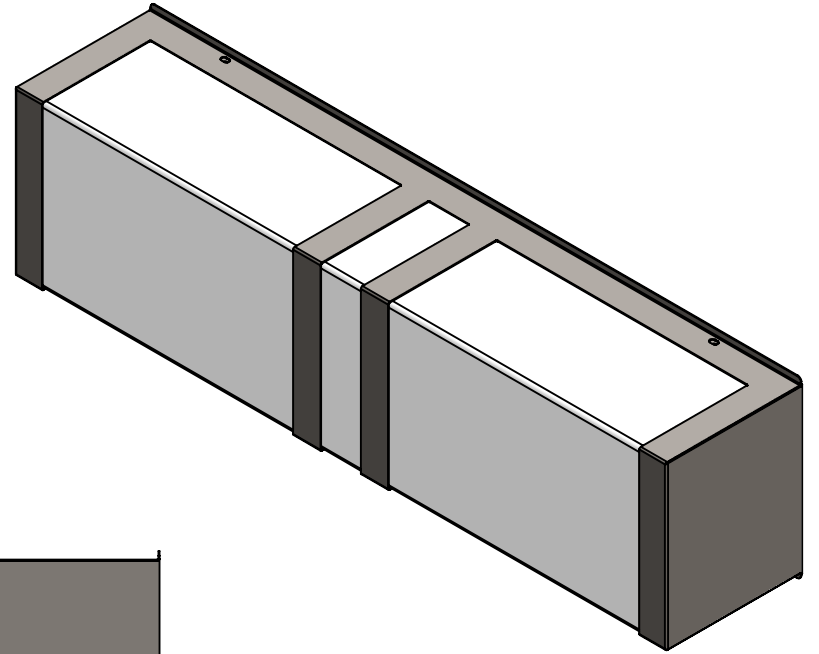

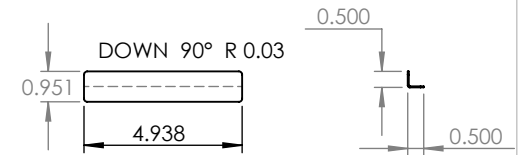
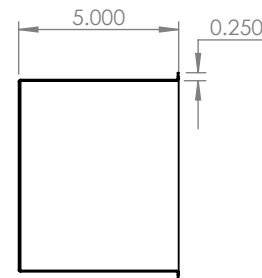
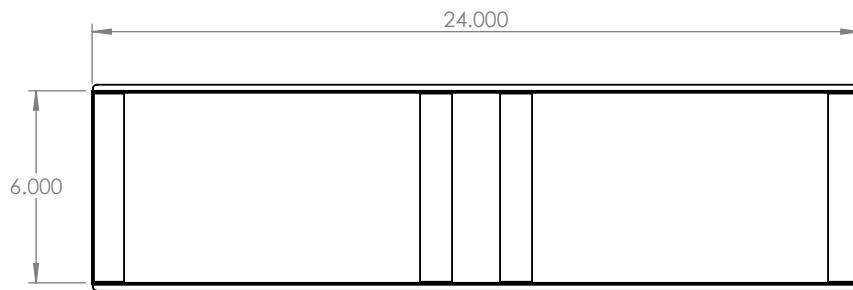
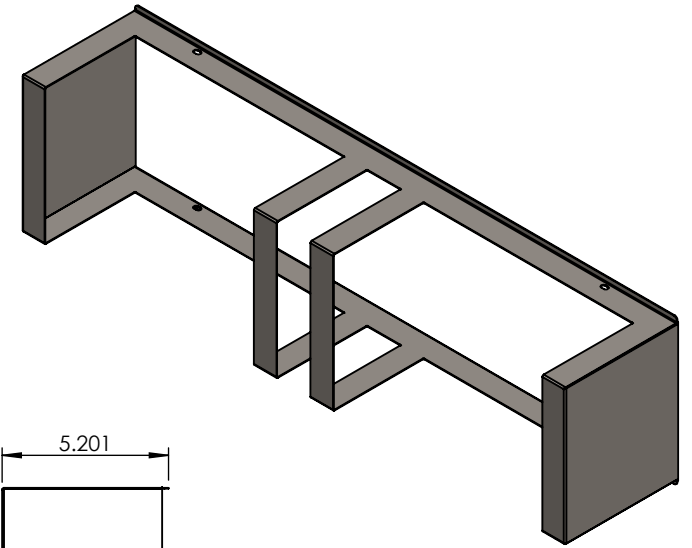
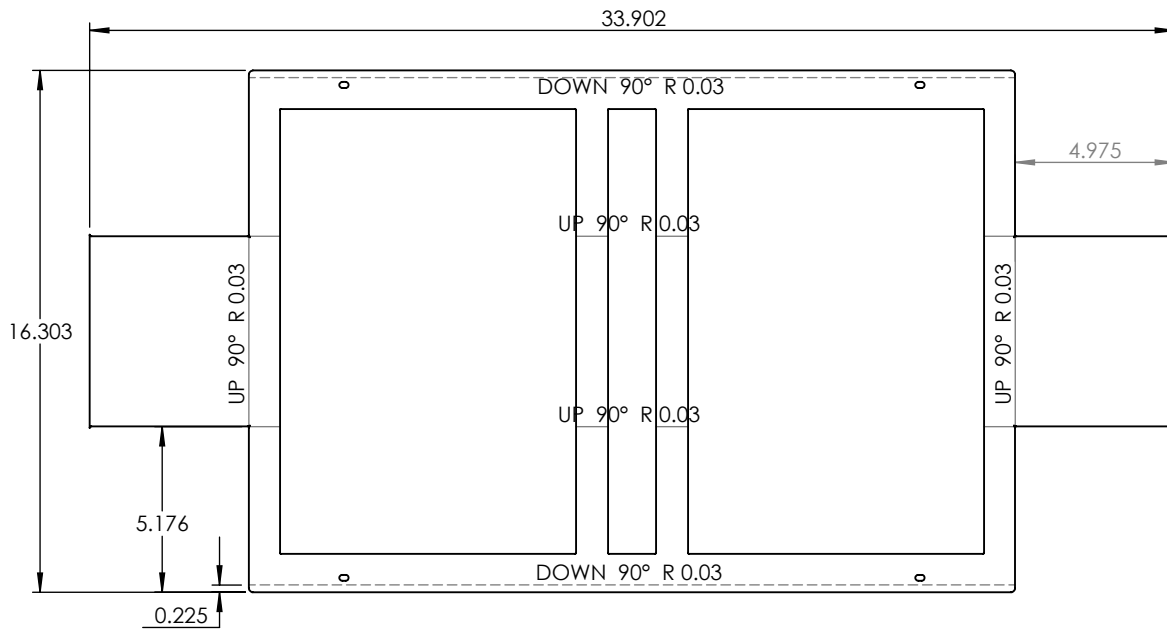

PROPRIETARY AND CONFIDENTIAL
 THE INFORMATION CONTAINED IN THIS DRAWING IS THE SOLE PROPERTY OF <INSERT COMPANY NAME HERE>. ANY REPRODUCTION IN PART OR AS A WHOLE WITHOUT THE WRITTEN PERMISSION OF <INSERT COMPANY NAME HERE> IS PROHIBITED.

NEXT ASSY	USED ON
APPLICATION	

UNLESS OTHERWISE SPECIFIED:
DIMENSIONS ARE IN INCHES
TOLERANCES:
FRACTIONAL ±
ANGULAR: MACH ± BEND ±
TWO PLACE DECIMAL ±
THREE PLACE DECIMAL ±
INTERPRET GEOMETRIC TOLERANCING PER:
MATERIAL
FINISH
DO NOT SCALE DRAWING

	NAME	DATE
DRAWN		
CHECKED		
ENG APPR.		
MFG APPR.		
Q.A.		
COMMENTS:		

22 GAUGE		
TITLE:		
ME-W-24-16W-MN-WF-27K		
SIZE	DWG. NO.	REV
A		
SCALE: 1:6	WEIGHT:	SHEET 3 OF 4

5

4

3

2

1

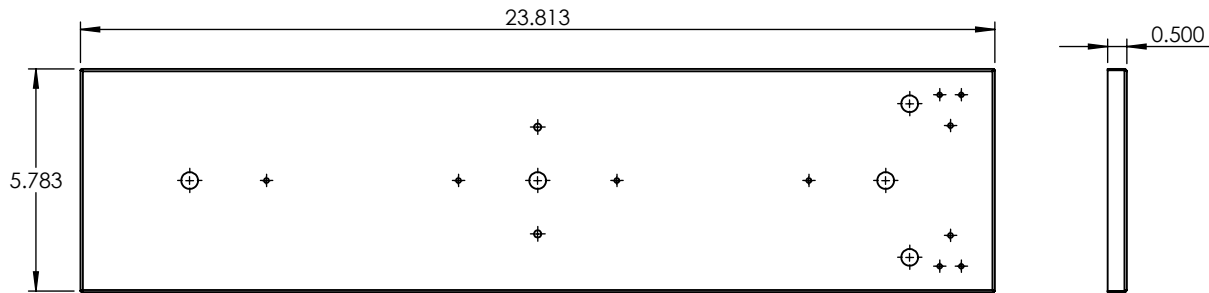
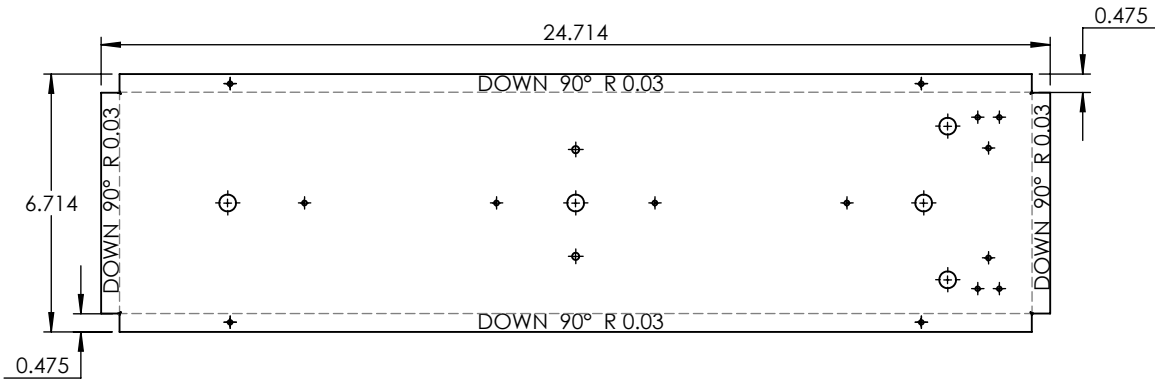
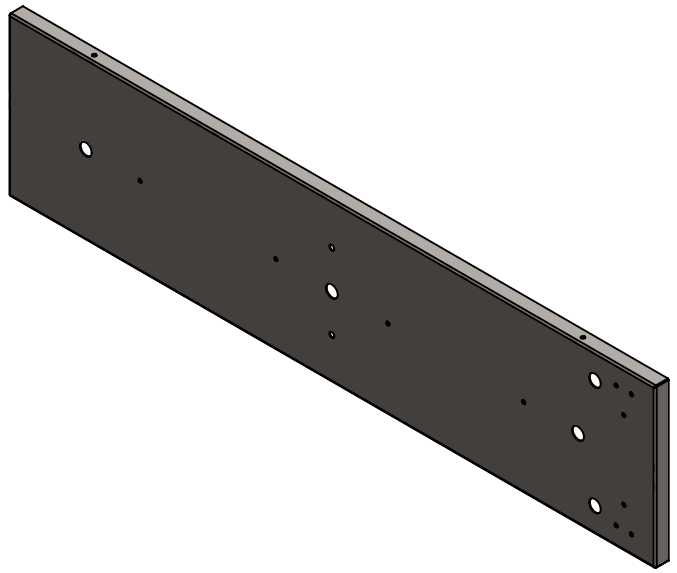

UNLESS OTHERWISE SPECIFIED:		NAME	DATE	22 GAUGE	
DIMENSIONS ARE IN INCHES TOLERANCES: FRACTIONAL ± ANGULAR: MACH ± BEND ± TWO PLACE DECIMAL ± THREE PLACE DECIMAL ±		DRAWN			
INTERPRET GEOMETRIC TOLERANCING PER:		CHECKED		SIZE	DWG. NO.
MATERIAL		ENG APPR.			
FINISH		MFG APPR.		SCALE: 1:5 WEIGHT:	
NEXT ASSY		Q.A.		SHEET 4 OF 4	
USED ON		COMMENTS:			
APPLICATION		DO NOT SCALE DRAWING			

PROPRIETARY AND CONFIDENTIAL
 THE INFORMATION CONTAINED IN THIS DRAWING IS THE SOLE PROPERTY OF <INSERT COMPANY NAME HERE>. ANY REPRODUCTION IN PART OR AS A WHOLE WITHOUT THE WRITTEN PERMISSION OF <INSERT COMPANY NAME HERE> IS PROHIBITED.