

ITEM NO.	PART NUMBER	DESCRIPTION	QTY.	CUT
1	EX-14"-2G24Q3-MN-A-BH1"-NL-BACKPLATE	22 GAUGE	1	
2	EX-14"-2G24Q3-MN-A-BH1"-NL-FRAME	22 GAUGE	1	
3	EX-14"-2G24Q3-MN-A-BH1"-NL-PYRAMID OUTSIDE FLANGES	22 GAUGE	4	
4	EX-14"-2G24Q3-MN-A-BH1"-NL-ACRYLIC	ACRYLIC	4	
5	QUAD PIN SOCKET HORIZONTAL	SOCKET	2	

UNLESS OTHERWISE SPECIFIED:

DIMENSIONS ARE IN INCHES
 TOLERANCES:
 FRACTIONAL ± .003
 ANGULAR: MACH ± .01 BEND ±
 TWO PLACE DECIMAL ±
 THREE PLACE DECIMAL ±.001

INTERPRET GEOMETRIC
 TOLERANCING PER:

MATERIAL

FINISH

	NAME	DATE
DRAWN		
CHECKED		
ENG APPR.		
MFG APPR.		
Q.A.		

COMMENTS:

TITLE:

EX-14"-2G24Q3-MN-A-BH1"-NL

SIZE	DWG. NO.	REV
A	TICKET 25178	

SCALE: 1:5 WEIGHT: SHEET 1 OF 5



ALL BEND RADIUS .030"

APPLICATION

DO NOT SCALE DRAWING

5

4

3

2

1

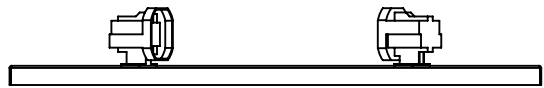
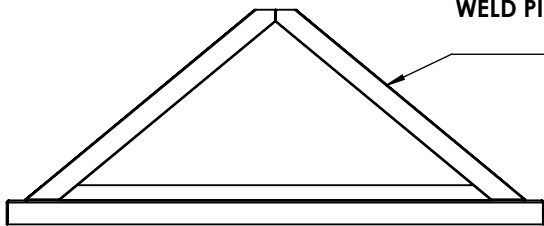
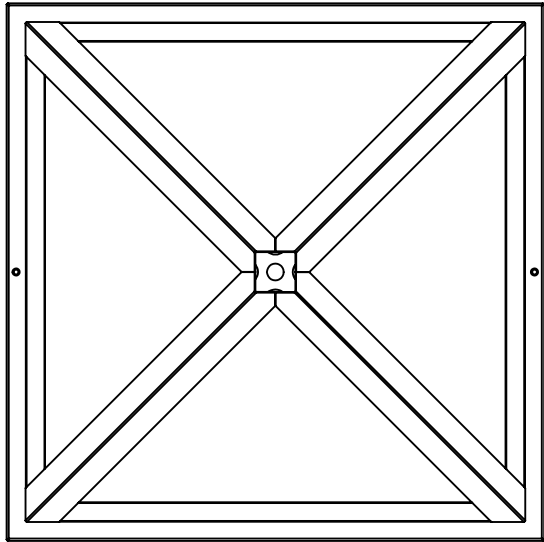
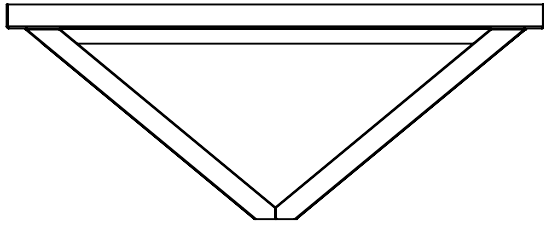

**FLANGES GO ON THE OUTSIDE. MINIMUM HIT MARKS!!
WELD PIECES IF POSSIBLE, GRIND ALL OUTSIDE MARKS FOR
GOOD FINISH!!!**

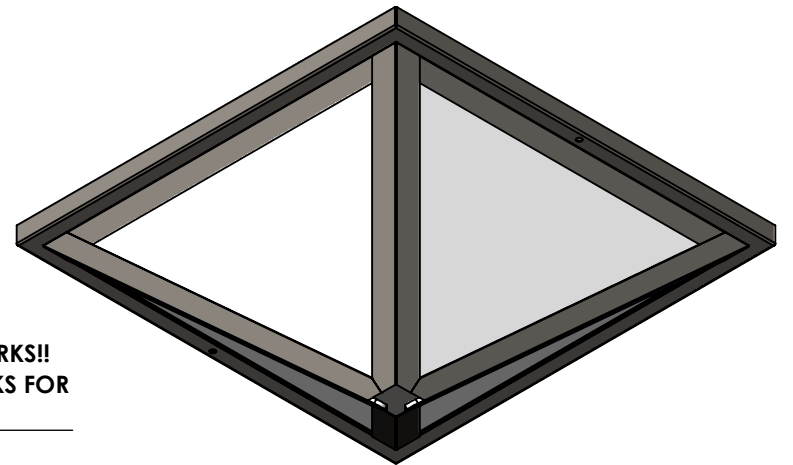
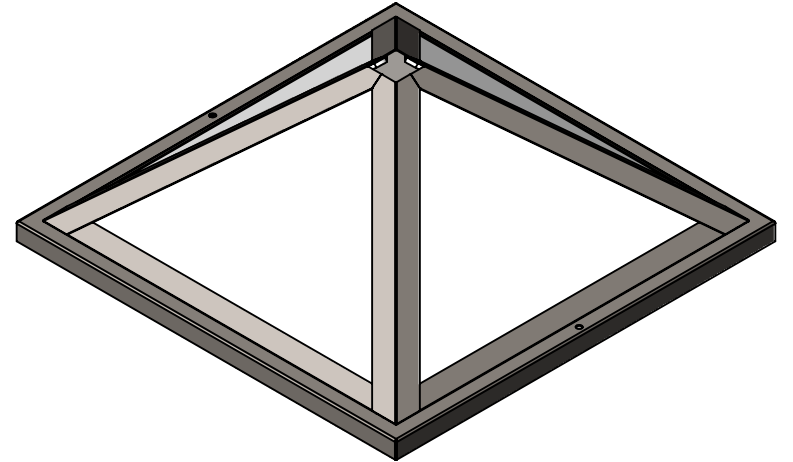

5

4

3

2

1

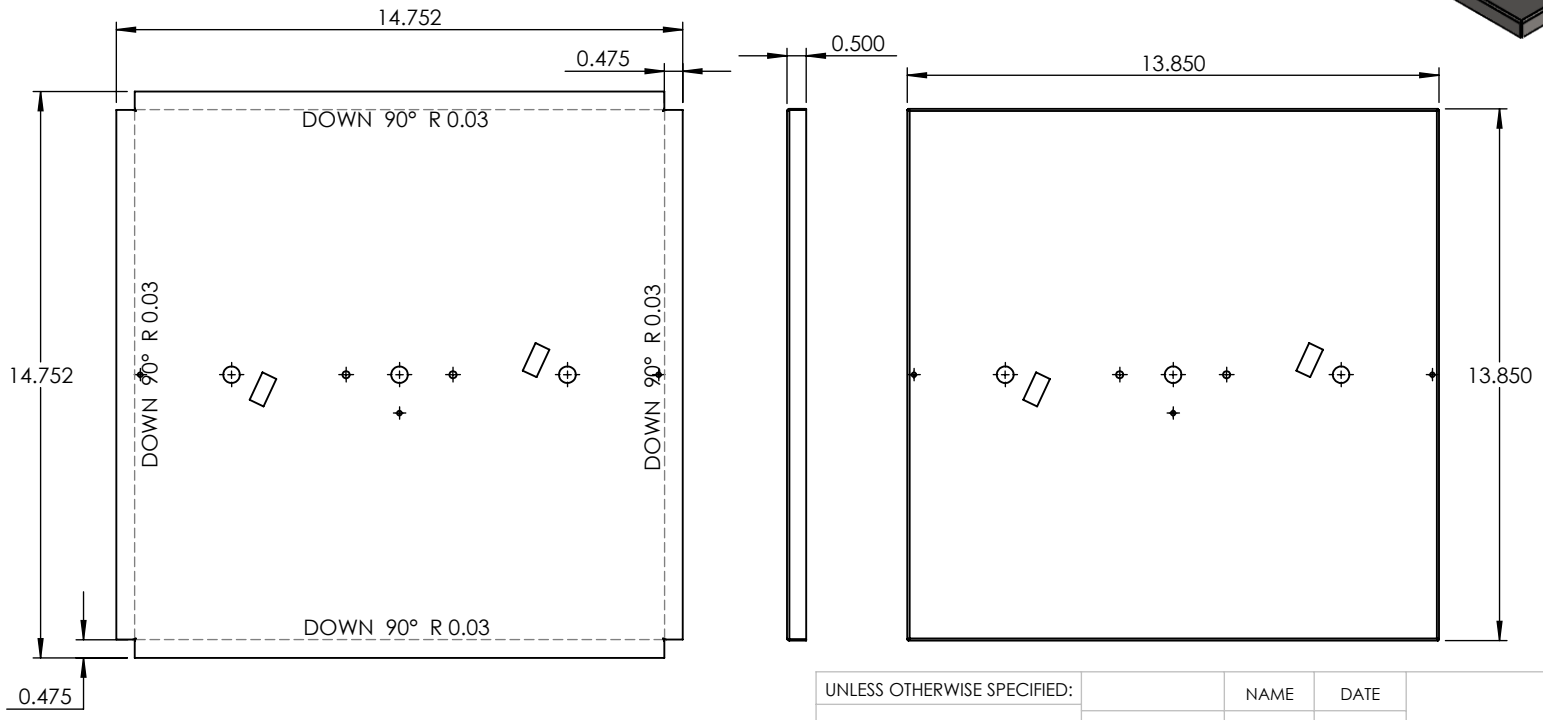
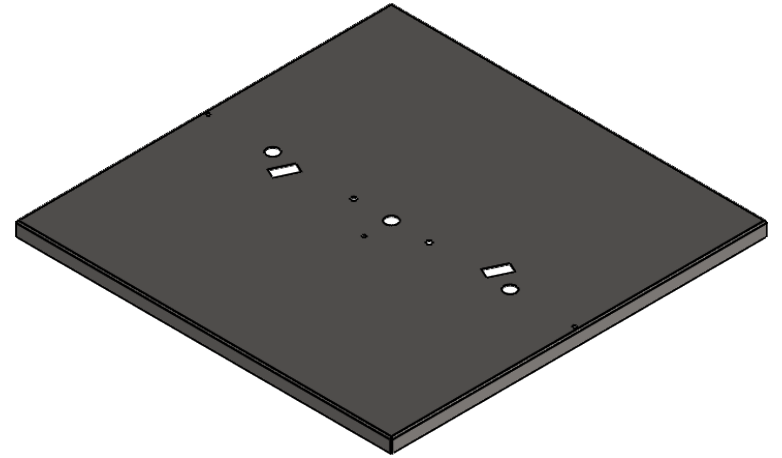

UNLESS OTHERWISE SPECIFIED:

DIMENSIONS ARE IN INCHES
 TOLERANCES:
 FRACTIONAL ±
 ANGULAR: MACH ± BEND ±
 TWO PLACE DECIMAL ±
 THREE PLACE DECIMAL ±

INTERPRET GEOMETRIC TOLERANCING PER:

MATERIAL

FINISH

DO NOT SCALE DRAWING

NAME	DATE

DRAWN

CHECKED

ENG APPR.

MFG APPR.

Q.A.

COMMENTS:

22 GAUGE

TITLE:

EX-14"-2G24Q3-MN-A-BH1"-NL

SIZE
A

DWG. NO.

REV

SCALE: 1:5

WEIGHT:

SHEET 3 OF 5

PROPRIETARY AND CONFIDENTIAL
 THE INFORMATION CONTAINED IN THIS DRAWING IS THE SOLE PROPERTY OF <INSERT COMPANY NAME HERE>. ANY REPRODUCTION IN PART OR AS A WHOLE WITHOUT THE WRITTEN PERMISSION OF <INSERT COMPANY NAME HERE> IS PROHIBITED.

NEXT ASSY	USED ON
APPLICATION	

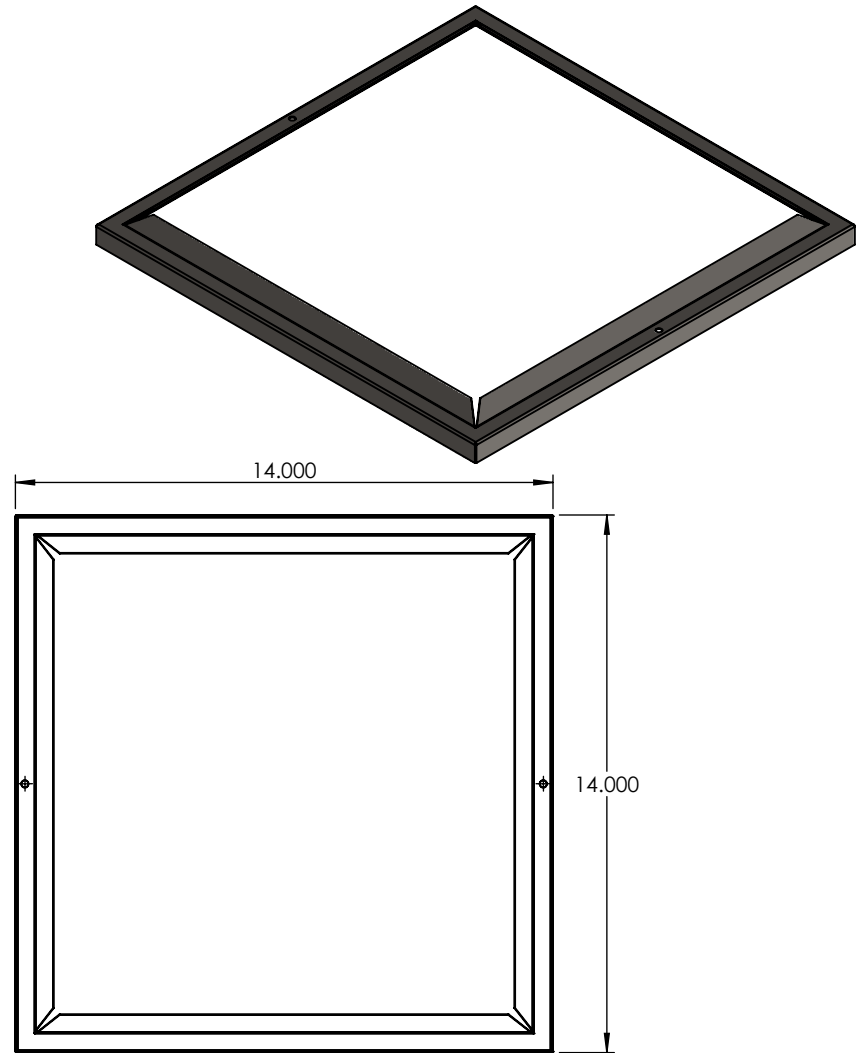
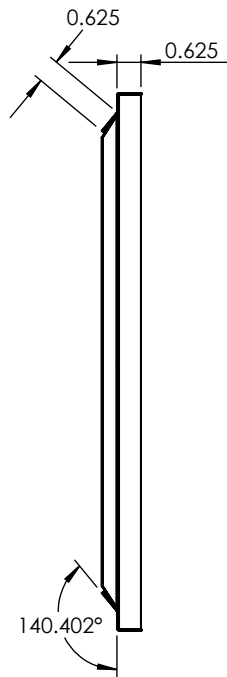
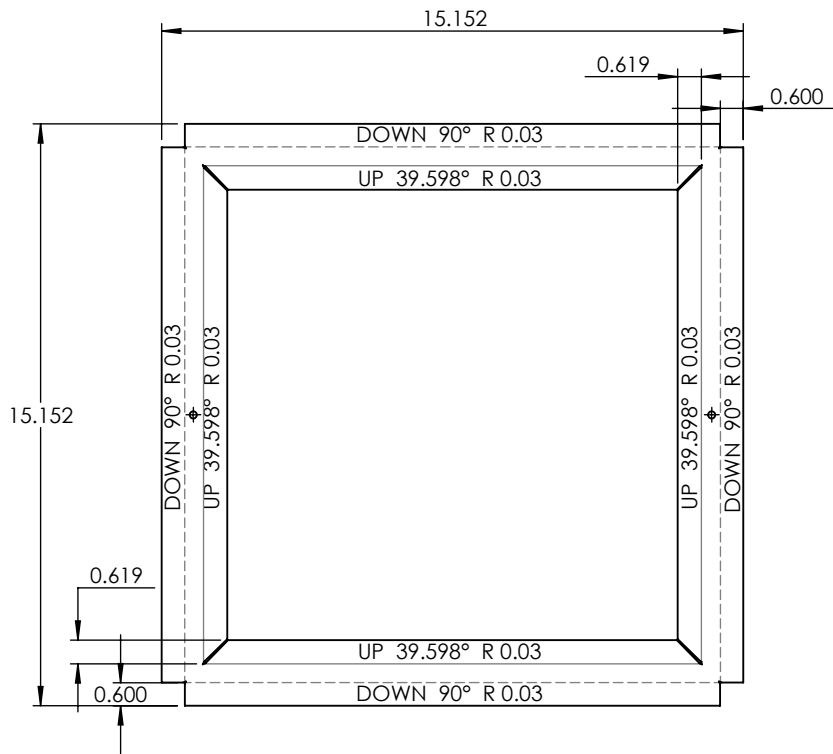

UNLESS OTHERWISE SPECIFIED:

DIMENSIONS ARE IN INCHES
 TOLERANCES:
 FRACTIONAL ±
 ANGULAR: MACH ± BEND ±
 TWO PLACE DECIMAL ±
 THREE PLACE DECIMAL ±

INTERPRET GEOMETRIC
 TOLERANCING PER:

MATERIAL

FINISH

DO NOT SCALE DRAWING

NAME DATE

DRAWN
 CHECKED
 ENG APPR.
 MFG APPR.

Q.A.
 COMMENTS:

22 GAUGE

TITLE:

EX-14"-2G24Q3-MN-A-BH1"-NL

SIZE	DWG. NO.	REV
A		

SCALE: 1:5	WEIGHT:	SHEET 4 OF 5
------------	---------	--------------

PROPRIETARY AND CONFIDENTIAL
 THE INFORMATION CONTAINED IN THIS
 DRAWING IS THE SOLE PROPERTY OF
 <INSERT COMPANY NAME HERE>. ANY
 REPRODUCTION IN PART OR AS A WHOLE
 WITHOUT THE WRITTEN PERMISSION OF
 <INSERT COMPANY NAME HERE> IS
 PROHIBITED.

NEXT ASSY	USED ON
APPLICATION	

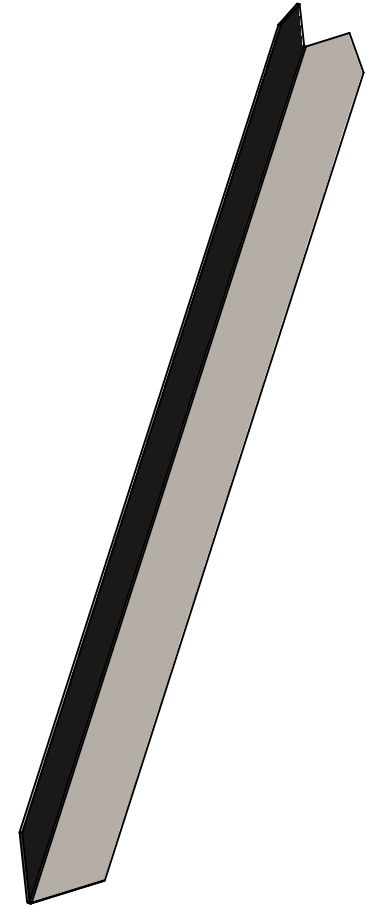
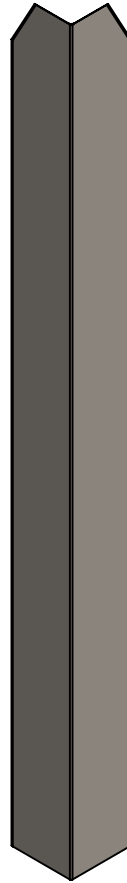
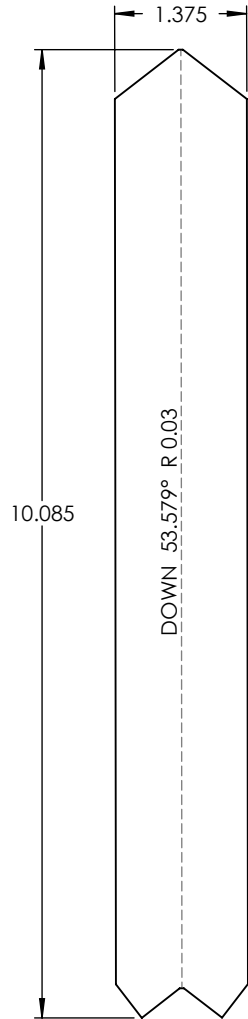
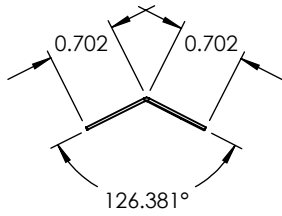

PROPRIETARY AND CONFIDENTIAL
 THE INFORMATION CONTAINED IN THIS DRAWING IS THE SOLE PROPERTY OF <INSERT COMPANY NAME HERE>. ANY REPRODUCTION IN PART OR AS A WHOLE WITHOUT THE WRITTEN PERMISSION OF <INSERT COMPANY NAME HERE> IS PROHIBITED.

		UNLESS OTHERWISE SPECIFIED:		NAME	DATE	22 GAUGE		
		DIMENSIONS ARE IN INCHES TOLERANCES: FRACTIONAL ± ANGULAR: MACH ± BEND ± TWO PLACE DECIMAL ± THREE PLACE DECIMAL ±	DRAWN					
		INTERPRET GEOMETRIC TOLERANCING PER:	CHECKED			SIZE A	DWG. NO.	REV
		MATERIAL	ENG APPR.					
		FINISH	MFG APPR.					
NEXT ASSY	USED ON		Q.A.					
		APPLICATION	COMMENTS:					
		DO NOT SCALE DRAWING						

5

4

3

2

1