

ITEM NO.	PART NUMBER	DESCRIPTION	QTY.	CUT
1	WLCYLBB-V-16W-MN-A-18"-DIM-30K-ROUND FRAME	22 GAUGE	1	
2	WLCYLBB-V-16W-MN-A-18"-DIM-30K-ROUND FRAME CAP	22 GAUGE	2	
3	WLCYLBB-V-16W-MN-A-18"-DIM-30K-ROUND FRAME ACCENT	22 GAUGE	2	
4	WLCYLBB-V-16W-MN-A-18"-DIM-30K-FRAME	22 GAUGE	1	
5	WLCYLBB-V-16W-MN-A-18"-DIM-30K-CANOPY	22 GAUGE	1	
6	WLCYLBB-V-16W-MN-A-18"-DIM-30K-CANOPY TAB	22 GAUGE	4	
7	WLCYLBB-V-16W-MN-A-18"-DIM-30K-CANOPY PLATE	22 GAUGE	1	
8	WLCYLBB-V-16W-MN-A-18"-DIM-30K-LED PLATE	22 GAUGE	2	
9	WLCYLBB-V-16W-MN-A-18"-DIM-30K-FIREPLATE	22 GAUGE </td <td>1</td> <td></td>	1	
10	WLCYLBB-V-16W-MN-A-18"-DIM-30K-FIREPLATE TAB	22 GAUGE	4	
11	WLCYLBB-V-16W-MN-A-18"-DIM-30K-FIREPLATE TAB 2	22 GAUGE	4	
12	WLCYLBB-V-16W-MN-A-18"-DIM-30K-ACRYLIC	ACRYLIC	1	
13	FulhamThoroLED_T1M1UNV035015L_120277v	DRIVER	1	
14	AltaiLED_PN1004RevD	LED	2	

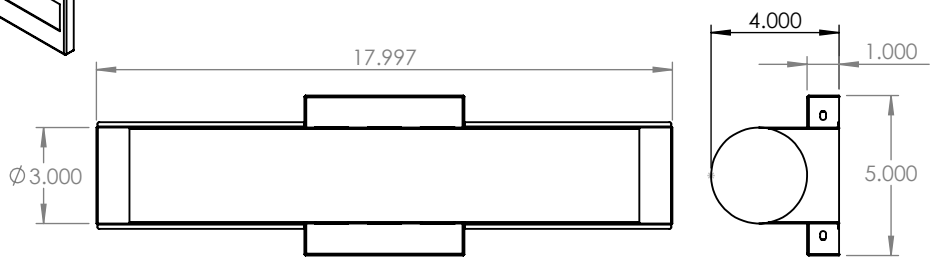
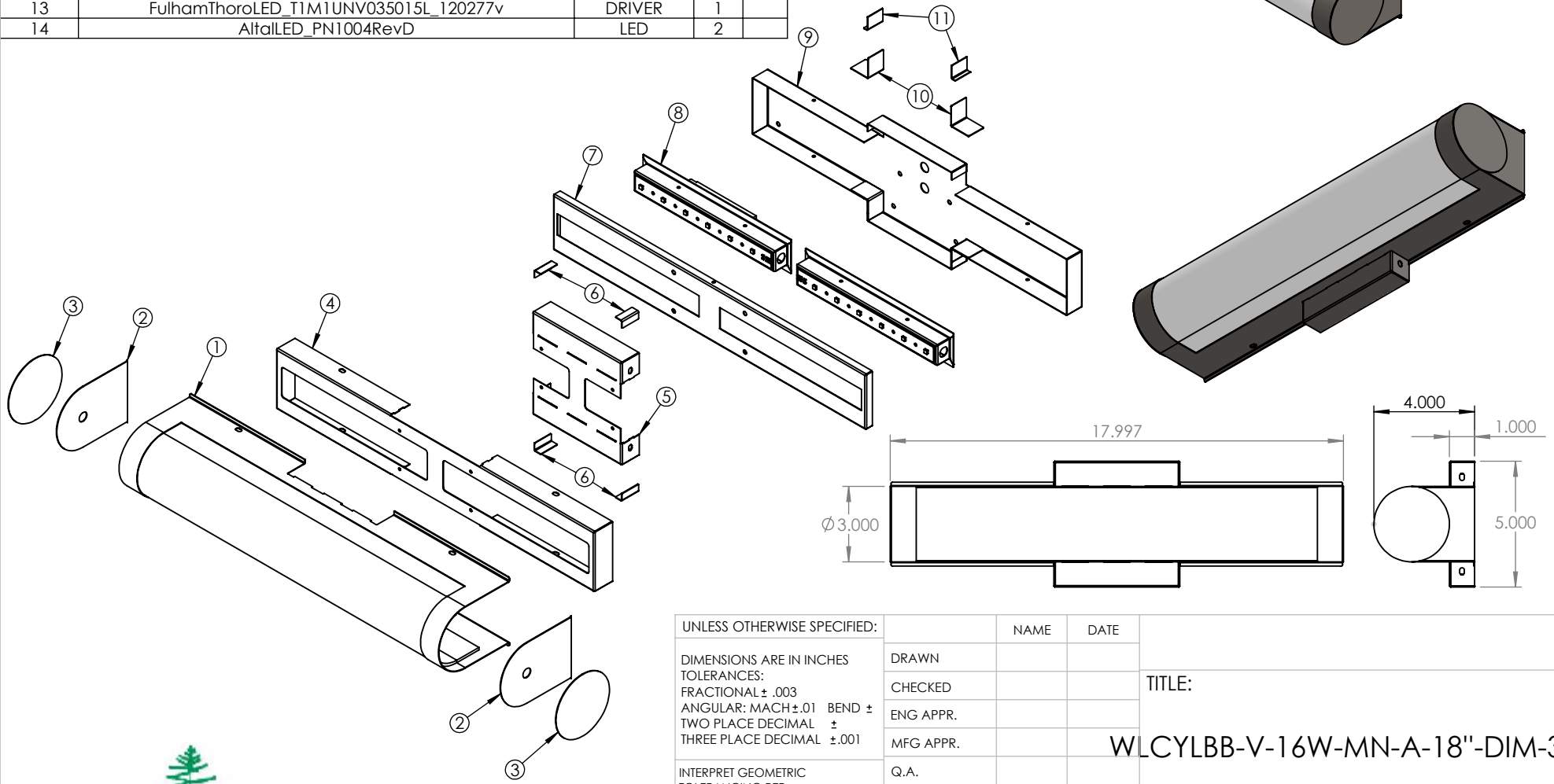

ALL BEND RADIUS .030"

APPLICATION

DO NOT SCALE DRAWING

UNLESS OTHERWISE SPECIFIED:

DIMENSIONS ARE IN INCHES
 TOLERANCES:
 FRACTIONAL ± .003
 ANGULAR: MACH ± .01 BEND ±
 TWO PLACE DECIMAL ±
 THREE PLACE DECIMAL ±.001

INTERPRET GEOMETRIC
 TOLERANCING PER:

MATERIAL

FINISH

NAME DATE

DRAWN
 CHECKED
 ENG APPR.
 MFG APPR.

Q.A.

COMMENTS:

TITLE:

WLCYLBB-V-16W-MN-A-18"-DIM-30K

SIZE DWG. NO. REV

A TICKET 25197

SCALE: 1:6 WEIGHT: SHEET 1 OF 10

5

4

3

2

1

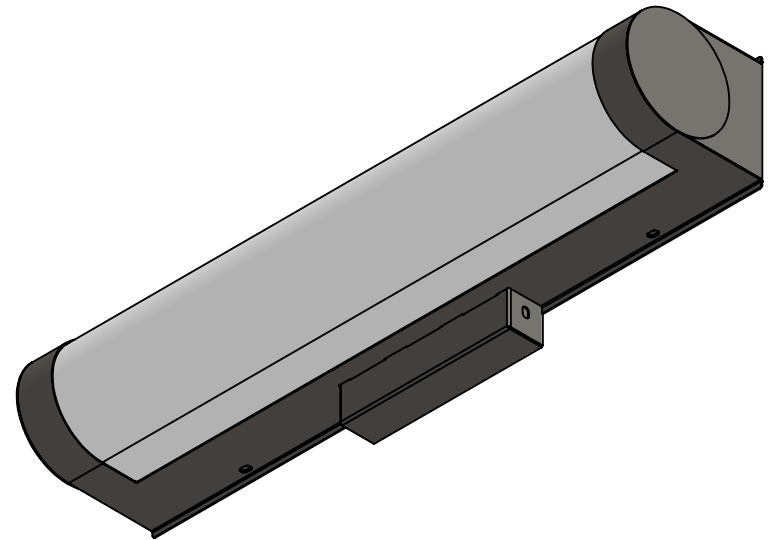
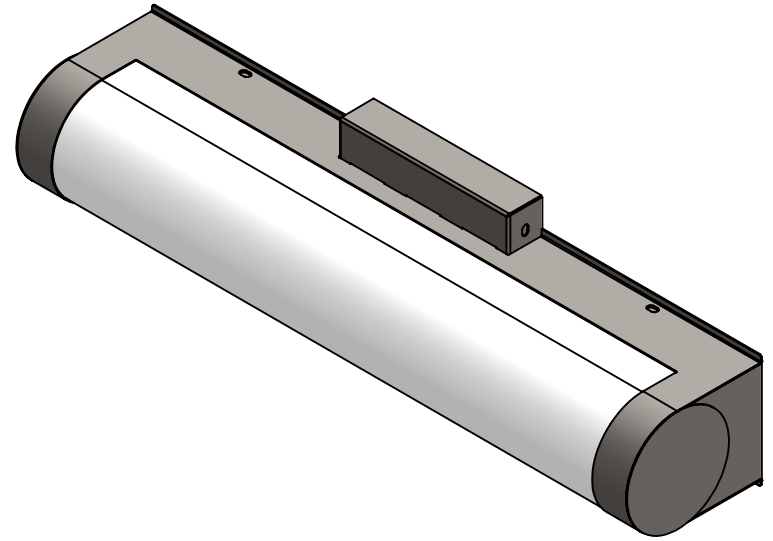
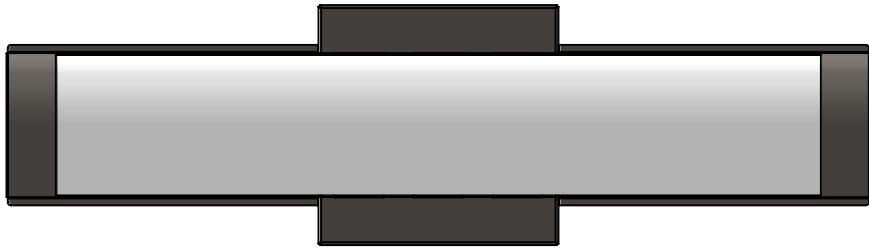

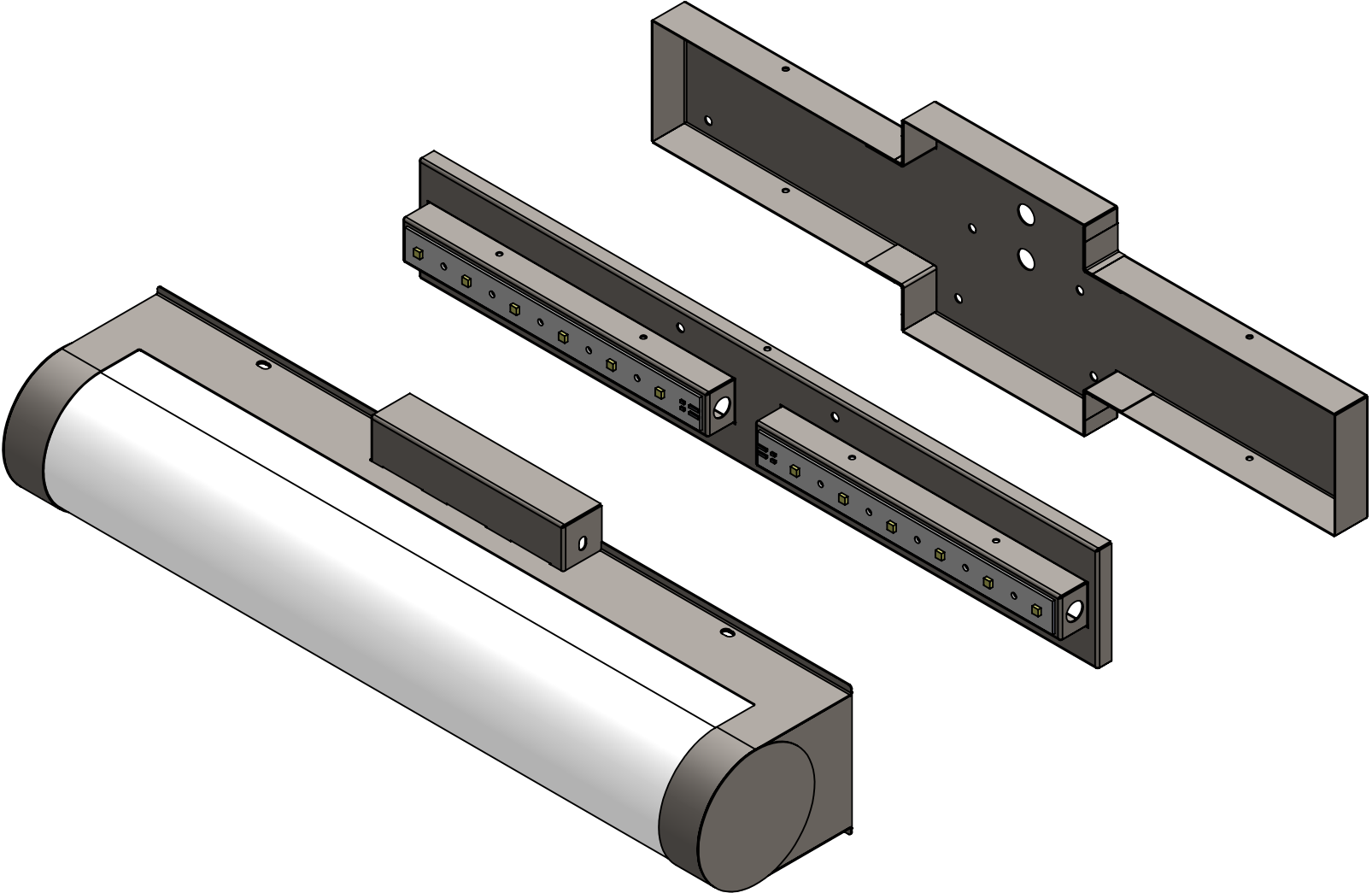

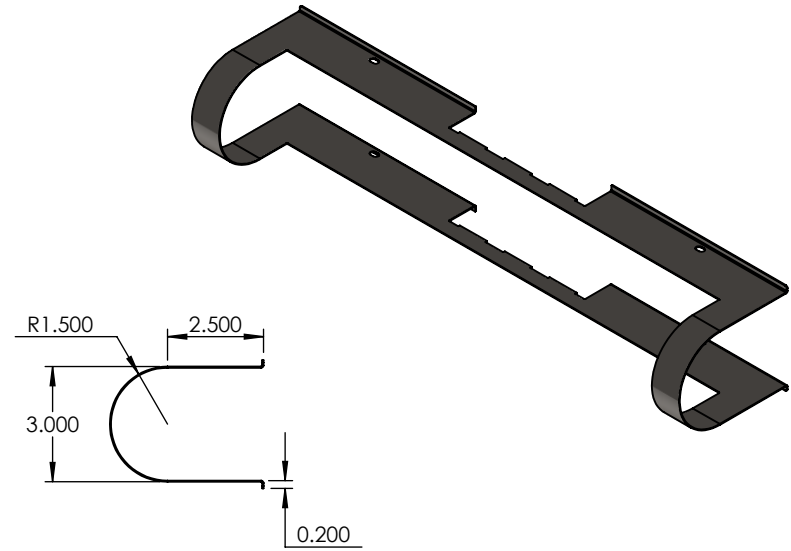
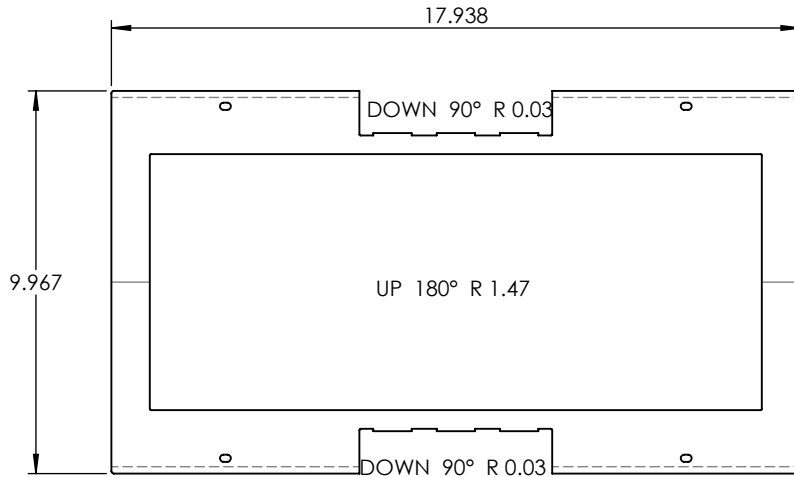
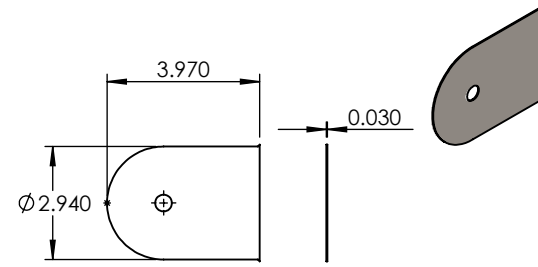
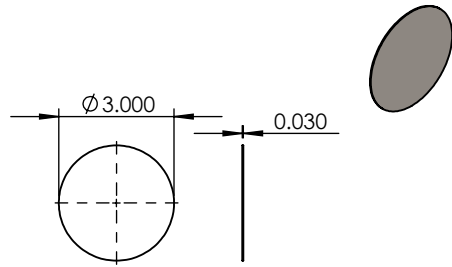

PROPRIETARY AND CONFIDENTIAL
 THE INFORMATION CONTAINED IN THIS DRAWING IS THE SOLE PROPERTY OF <INSERT COMPANY NAME HERE>. ANY REPRODUCTION IN PART OR AS A WHOLE WITHOUT THE WRITTEN PERMISSION OF <INSERT COMPANY NAME HERE> IS PROHIBITED.

		UNLESS OTHERWISE SPECIFIED:		NAME	DATE	22 GAUGE		
		DIMENSIONS ARE IN INCHES TOLERANCES: FRACTIONAL \pm ANGULAR: MACH \pm BEND \pm TWO PLACE DECIMAL \pm THREE PLACE DECIMAL \pm		DRAWN		TITLE:		
		INTERPRET GEOMETRIC TOLERANCING PER:		CHECKED		WLCYLBB-V-16W-MN-A-18"-DIM-30K		
		MATERIAL		ENG APPR.		SIZE	DWG. NO.	REV
	NEXT ASSY	FINISH		MFG APPR.		A		
	USED ON			Q.A.		SCALE: 1:5	WEIGHT:	SHEET 4 OF 10
	APPLICATION	DO NOT SCALE DRAWING		COMMENTS:				

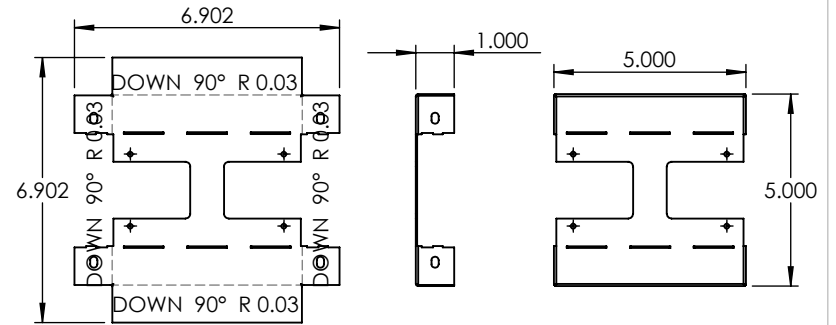
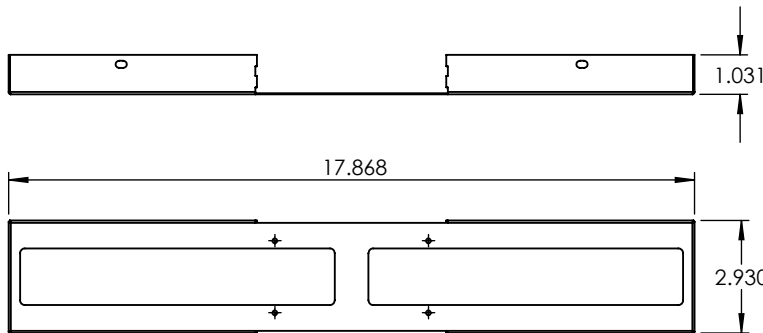
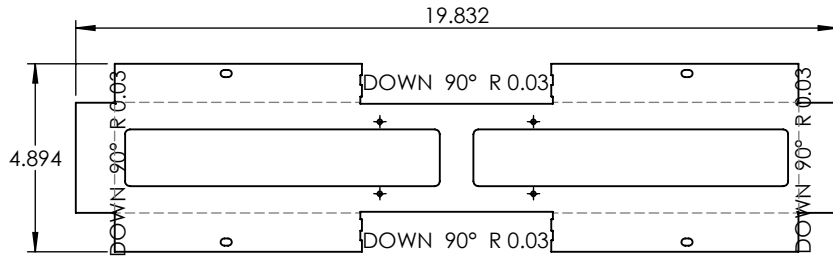
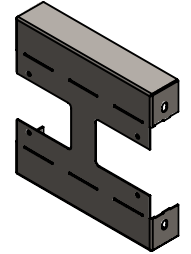
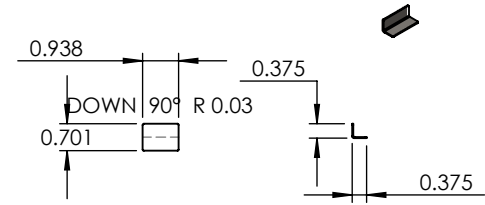
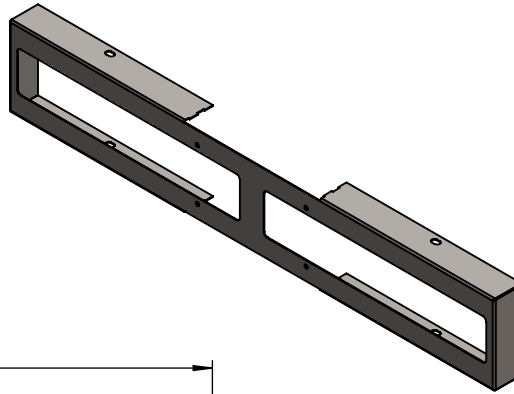

PROPRIETARY AND CONFIDENTIAL
 THE INFORMATION CONTAINED IN THIS DRAWING IS THE SOLE PROPERTY OF <INSERT COMPANY NAME HERE>. ANY REPRODUCTION IN PART OR AS A WHOLE WITHOUT THE WRITTEN PERMISSION OF <INSERT COMPANY NAME HERE> IS PROHIBITED.

		UNLESS OTHERWISE SPECIFIED:	NAME	DATE
		DIMENSIONS ARE IN INCHES	DRAWN	
		TOLERANCES:	CHECKED	
		FRACTIONAL ±	ENG APPR.	
		ANGULAR: MACH ± BEND ±	MFG APPR.	
		TWO PLACE DECIMAL ±	Q.A.	
		THREE PLACE DECIMAL ±	COMMENTS:	
		INTERPRET GEOMETRIC TOLERANCING PER:		
		MATERIAL		
NEXT ASSY	USED ON	FINISH		
APPLICATION		DO NOT SCALE DRAWING		

22 GAUGE		
TITLE:		
WLCYLBB-V-16W-MN-A-18"-DIM-30K		
SIZE	DWG. NO.	REV
A		
SCALE: 1:5	WEIGHT:	SHEET 5 OF 10

5

4

3

2

1

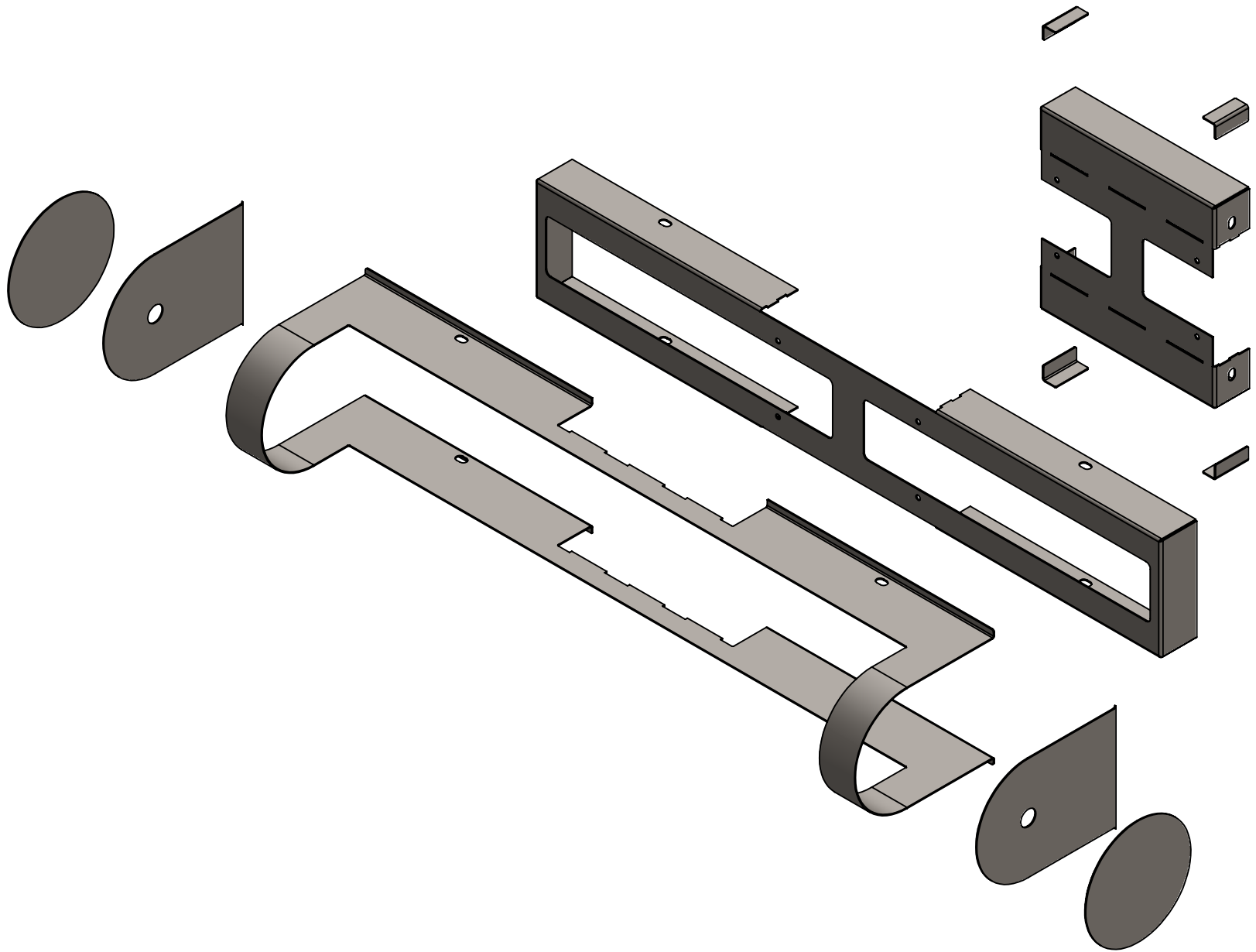

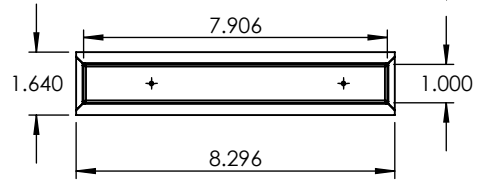
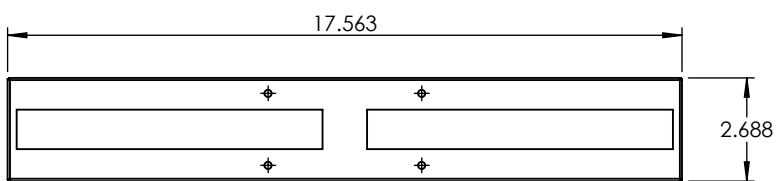
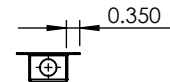
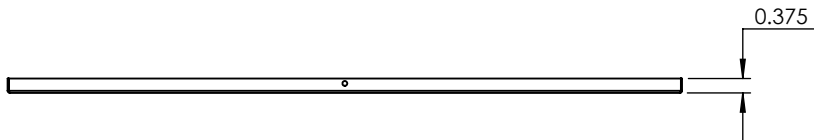
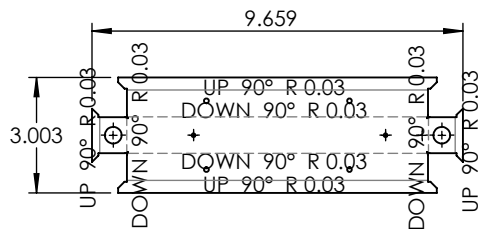
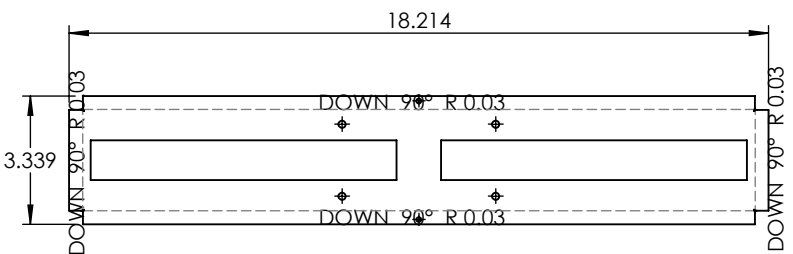
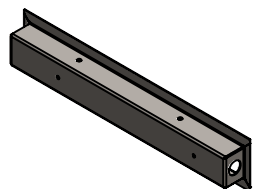
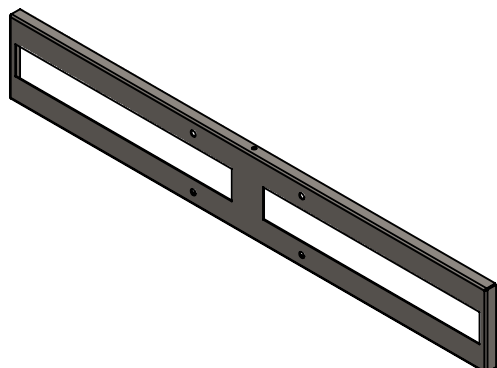

PROPRIETARY AND CONFIDENTIAL
 THE INFORMATION CONTAINED IN THIS DRAWING IS THE SOLE PROPERTY OF <INSERT COMPANY NAME HERE>. ANY REPRODUCTION IN PART OR AS A WHOLE WITHOUT THE WRITTEN PERMISSION OF <INSERT COMPANY NAME HERE> IS PROHIBITED.

		UNLESS OTHERWISE SPECIFIED:	NAME	DATE
		DIMENSIONS ARE IN INCHES	DRAWN	
		TOLERANCES:	CHECKED	
		FRACTIONAL ±	ENG APPR.	
		ANGULAR: MACH ± BEND ±	MFG APPR.	
		TWO PLACE DECIMAL ±	Q.A.	
		THREE PLACE DECIMAL ±	COMMENTS:	
		INTERPRET GEOMETRIC TOLERANCING PER:		
		MATERIAL		
NEXT ASSY	USED ON	FINISH		
APPLICATION		DO NOT SCALE DRAWING		

22 GAUGE		
TITLE:		
WLCYLBB-V-16W-MN-A-18"-DIM-30K		
SIZE	DWG. NO.	REV
A		
SCALE: 1:5	WEIGHT:	SHEET 7 OF 10

5

4

3

2

1



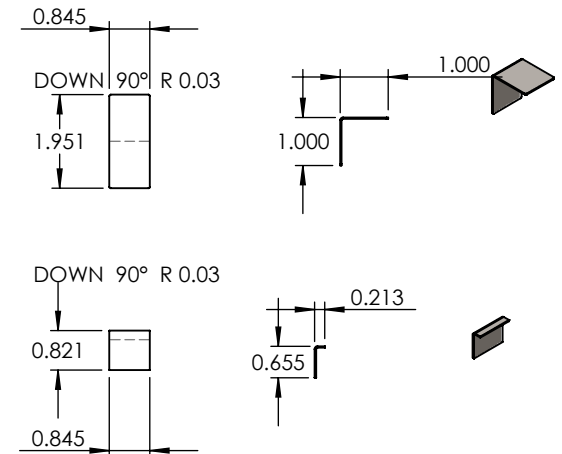
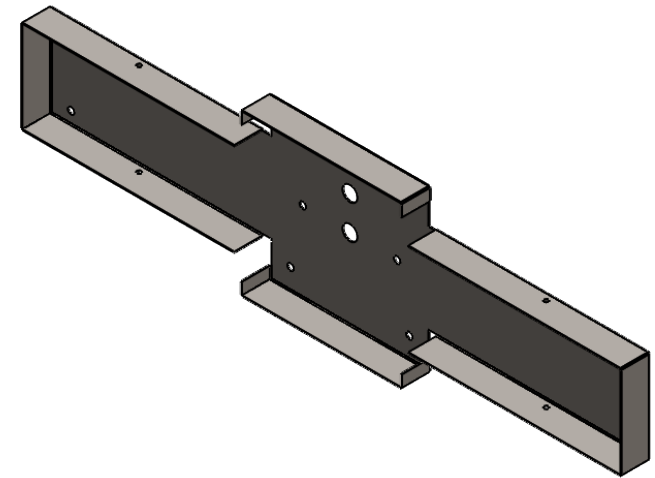
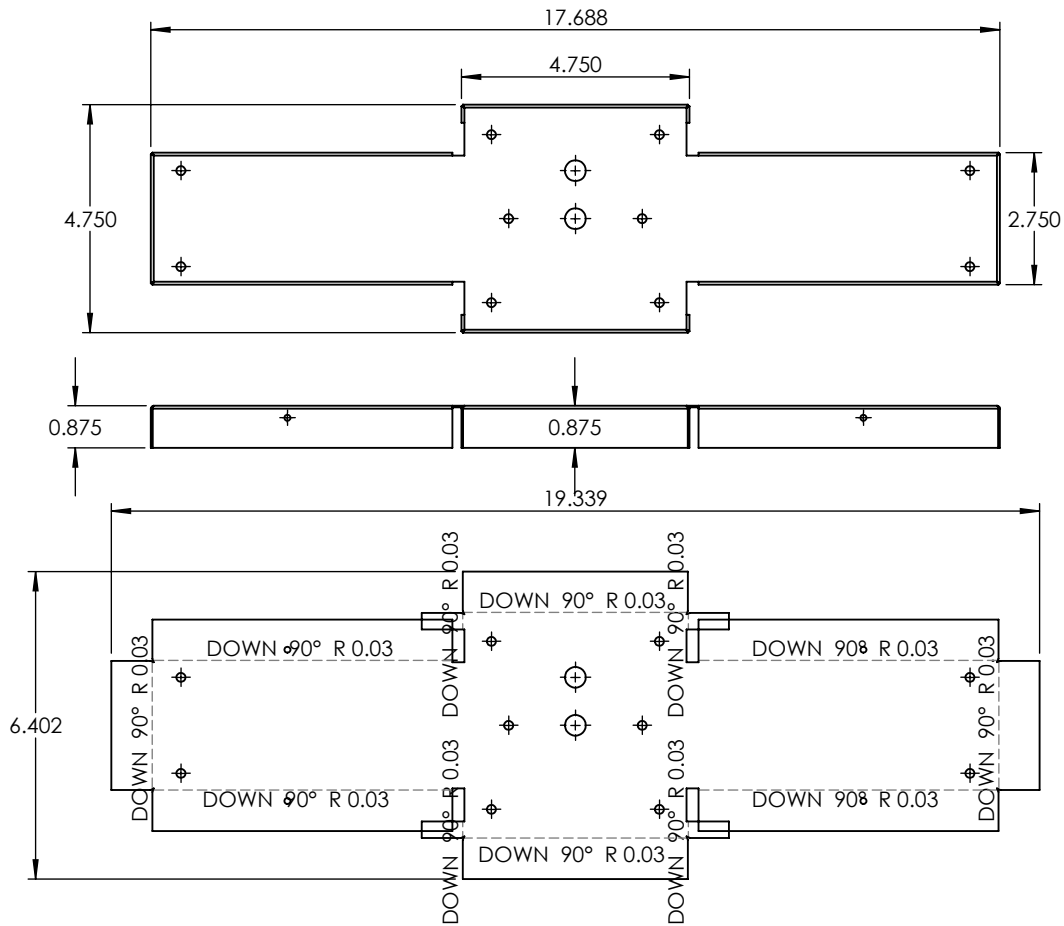

PROPRIETARY AND CONFIDENTIAL
 THE INFORMATION CONTAINED IN THIS DRAWING IS THE SOLE PROPERTY OF <INSERT COMPANY NAME HERE>. ANY REPRODUCTION IN PART OR AS A WHOLE WITHOUT THE WRITTEN PERMISSION OF <INSERT COMPANY NAME HERE> IS PROHIBITED.

		UNLESS OTHERWISE SPECIFIED:	NAME	DATE	22 GAUGE	
		DIMENSIONS ARE IN INCHES TOLERANCES: FRACTIONAL ± ANGULAR: MACH ± BEND ± TWO PLACE DECIMAL ± THREE PLACE DECIMAL ±	DRAWN			
		INTERPRET GEOMETRIC TOLERANCING PER:	CHECKED		WLCYLBB-V-16W-MN-A-18"-DIM-30K	
		MATERIAL	ENG APPR.			
		FINISH	MFG APPR.		SIZE	DWG. NO.
NEXT ASSY	USED ON		Q.A.		A	
APPLICATION	DO NOT SCALE DRAWING		COMMENTS:		SCALE: 1:4	WEIGHT:
						SHEET 9 OF 10

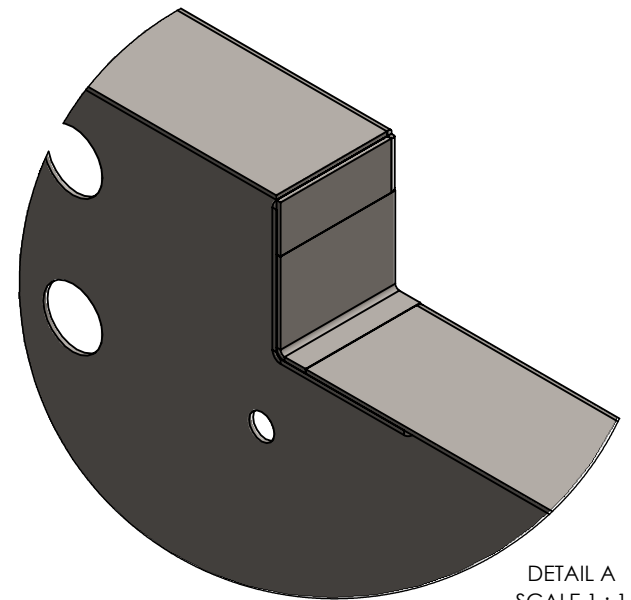
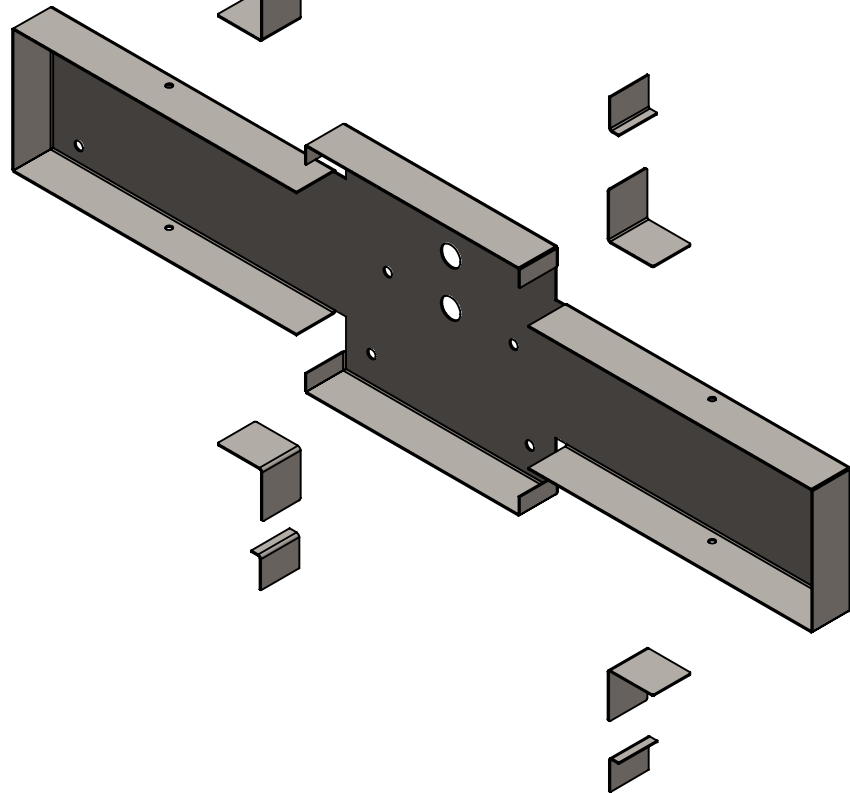
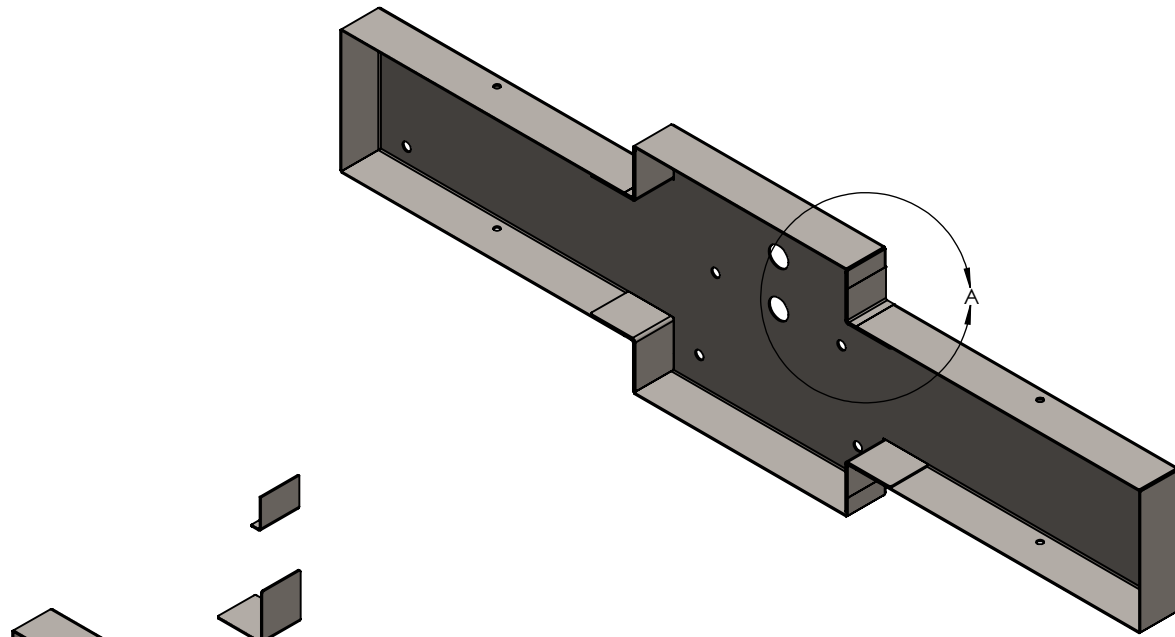

DETAIL A
SCALE 1 : 1