

ITEM NO.	PART NUMBER	DESCRIPTION	QTY.	CUT
1	ACR-BX-W-14W-AB-WF-DIM-30K-BACKPLATE	22 GAUGE	1	
2	ACR-BX-W-14W-AB-WF-DIM-30K-LENS PLATE	22 GAUGE	1	
3	ACR-BX-W-14W-AB-WF-DIM-30K-BAR ACCENT	1/4" ALUMINUM PLATE & 1/4"X1" ALUMINUM BAR	1	
4	ACR-BX-W-14W-AB-WF-DIM-30K-ACRYLIC BOX LENS	ACRYLIC	1	
5	UNIVERSAL ADAPTER	MOUNTING ADAPTER	1	
6	DS-15W-350C1542010-3001	DRIVER	1	
7	AltaILED_PN1010_RevD	LED	2	

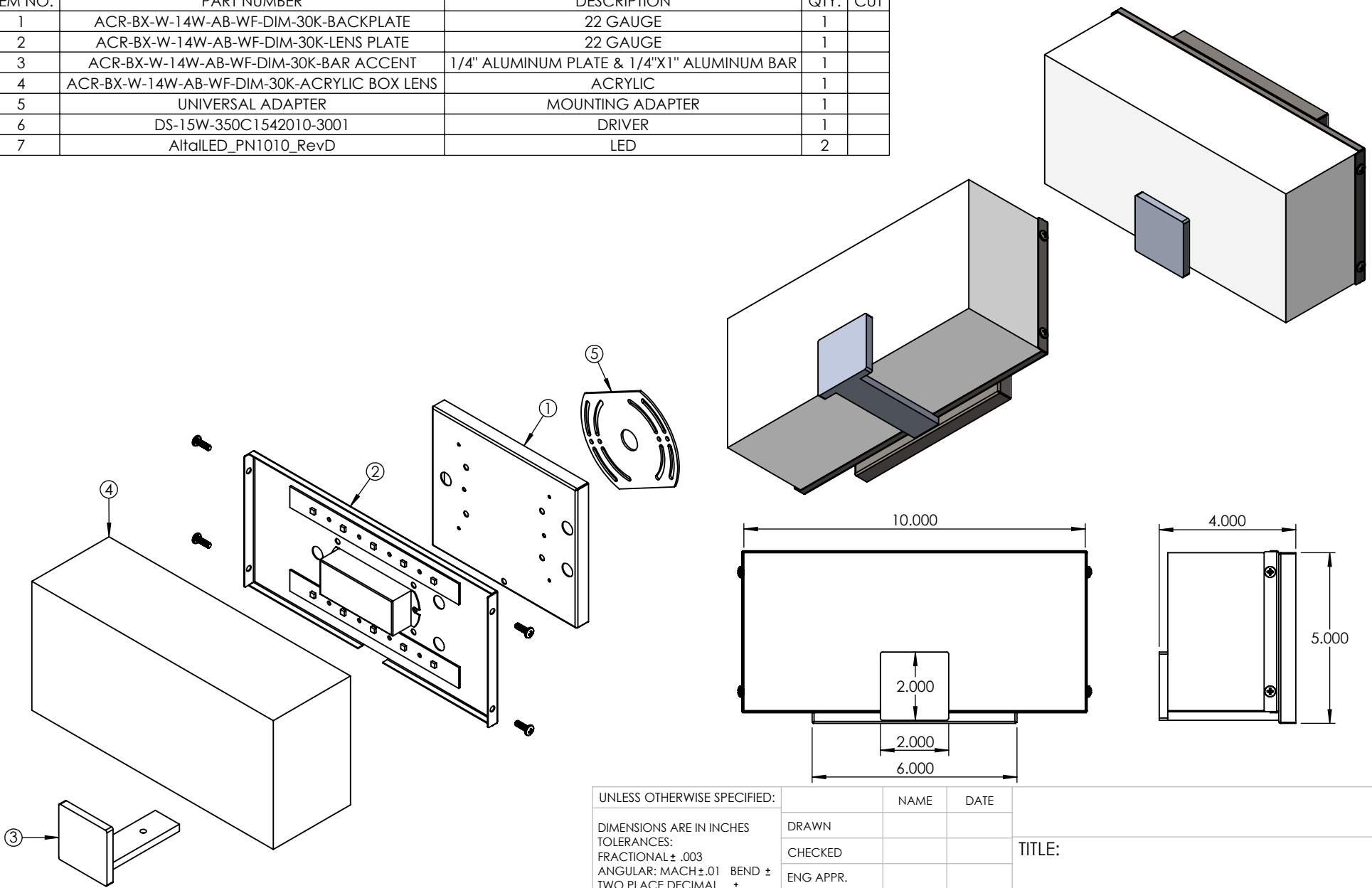

ALL BEND RADIUS .030"

UNLESS OTHERWISE SPECIFIED:

DIMENSIONS ARE IN INCHES
 TOLERANCES:
 FRACTIONAL ± .003
 ANGULAR: MACH ± .01 BEND ±
 TWO PLACE DECIMAL ±
 THREE PLACE DECIMAL ±.001

INTERPRET GEOMETRIC
 TOLERANCING PER:

MATERIAL

FINISH

DO NOT SCALE DRAWING

	NAME	DATE
DRAWN		
CHECKED		
ENG APPR.		
MFG APPR.		
Q.A.		
COMMENTS:		

TITLE:

ACR-BX-W-14W-AB-WF-DIM-30K

SIZE	DWG. NO.	REV
A	TICKET 21XXX	
SCALE: 1:4	WEIGHT:	SHEET 1 OF 7

5

4

3

2

1

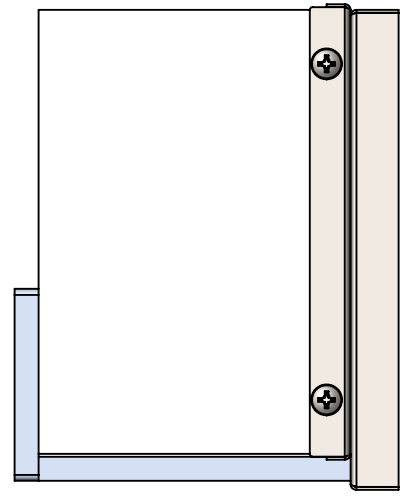
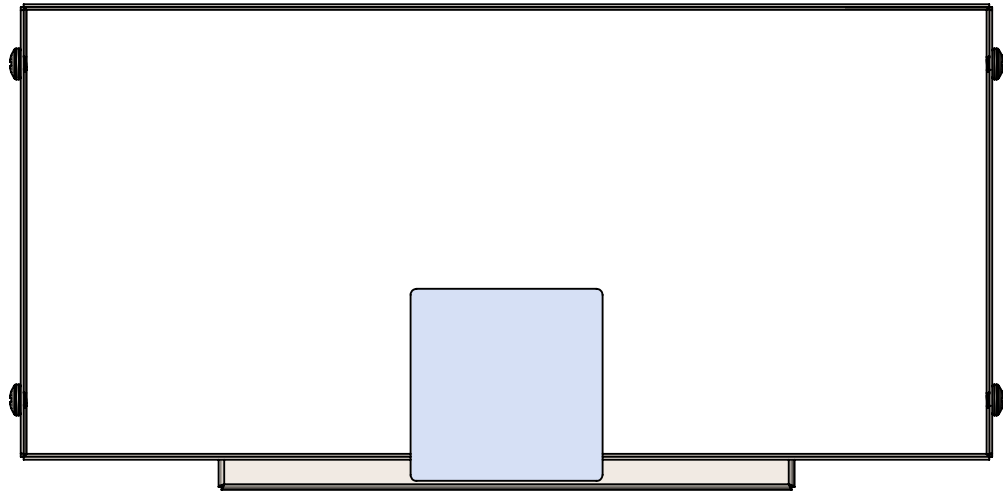
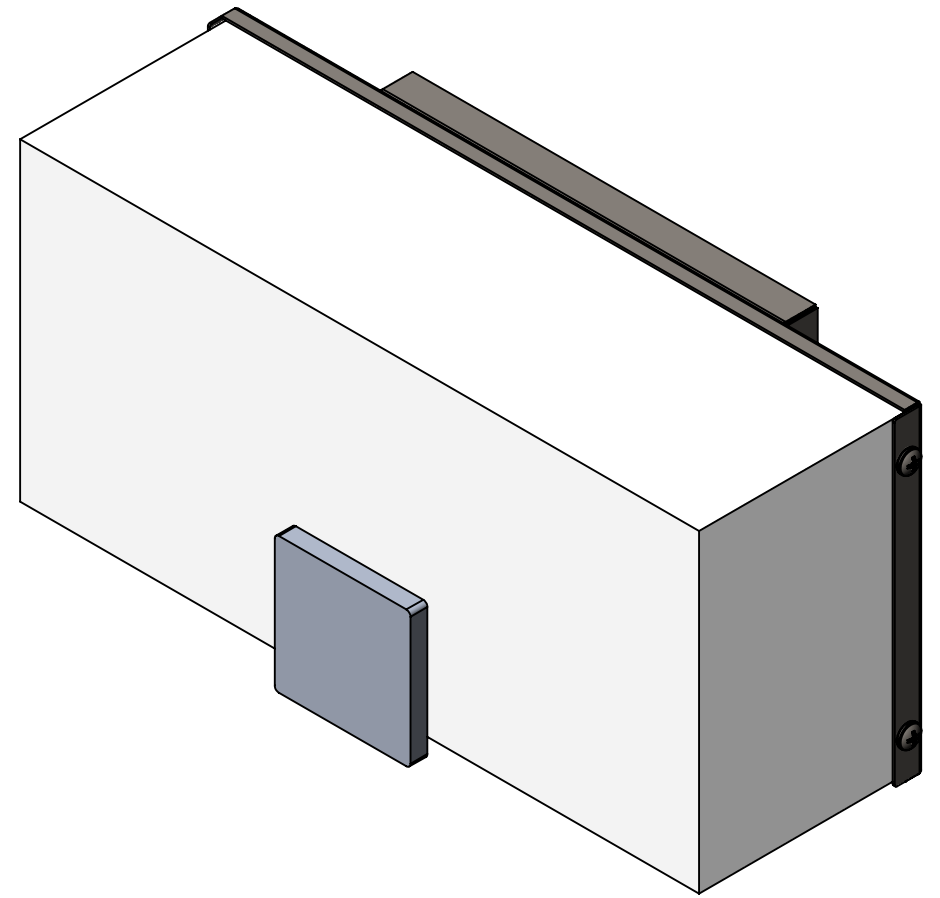
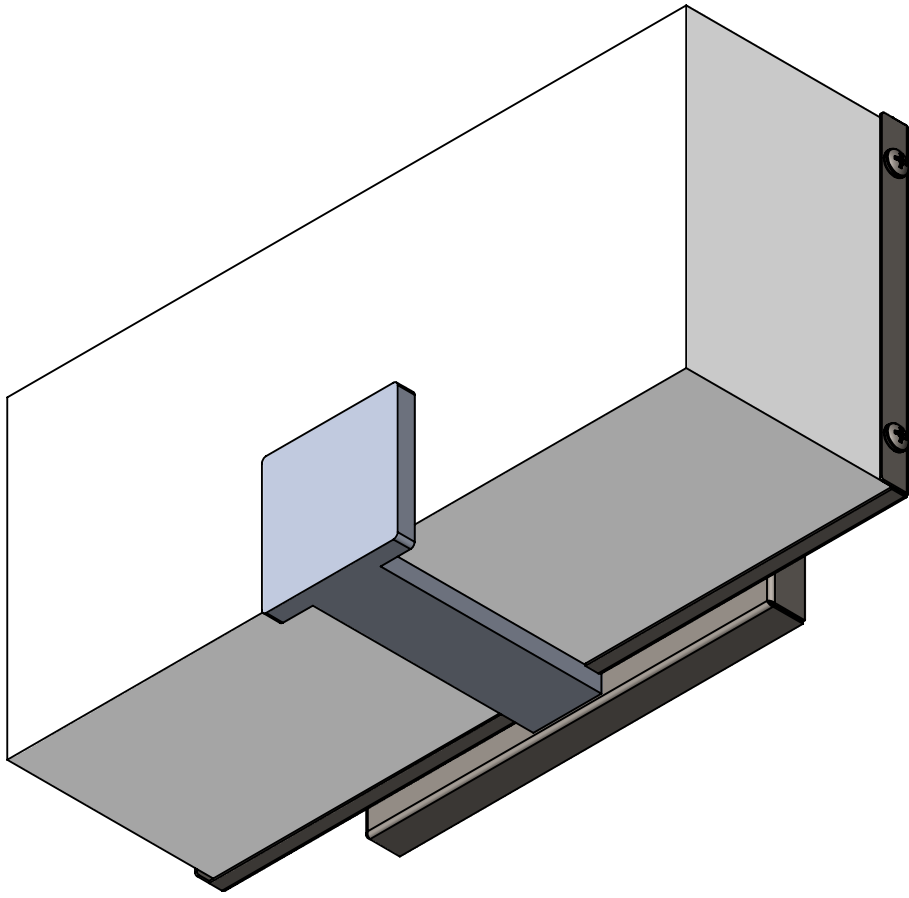

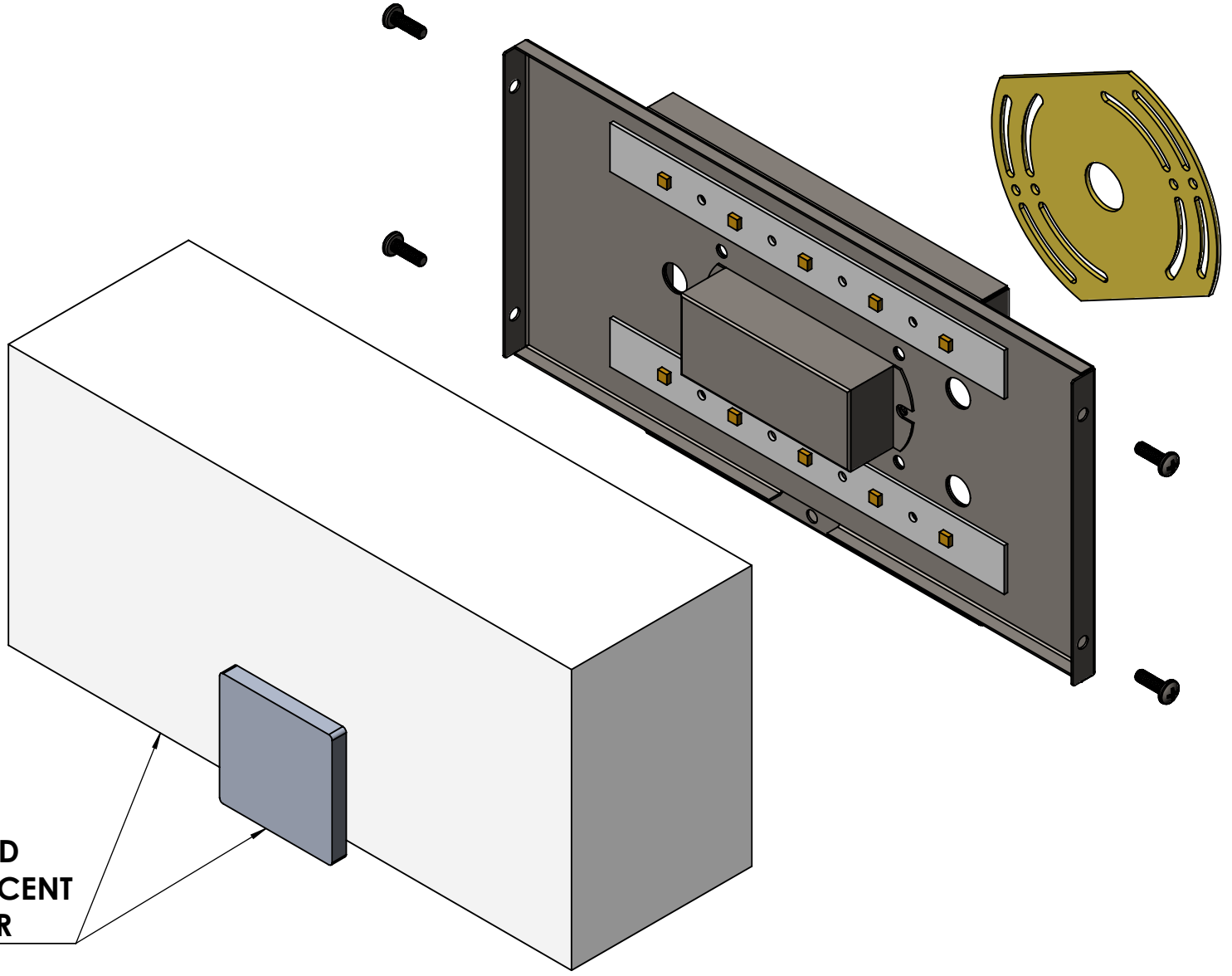

**ACRYLIC BOX AND
ALUMINUM PLATE ACCENT
BOLTED TOGETHER**

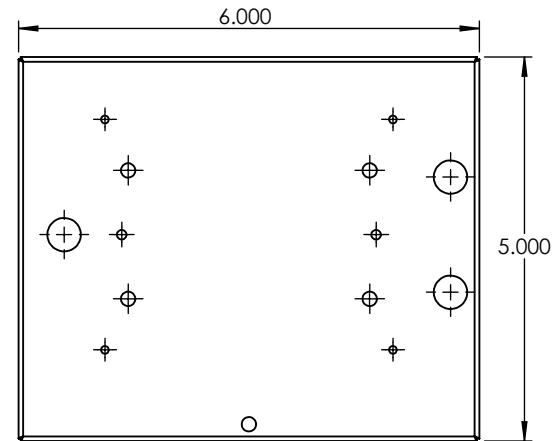
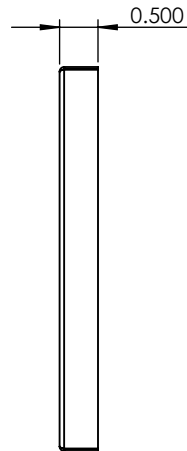
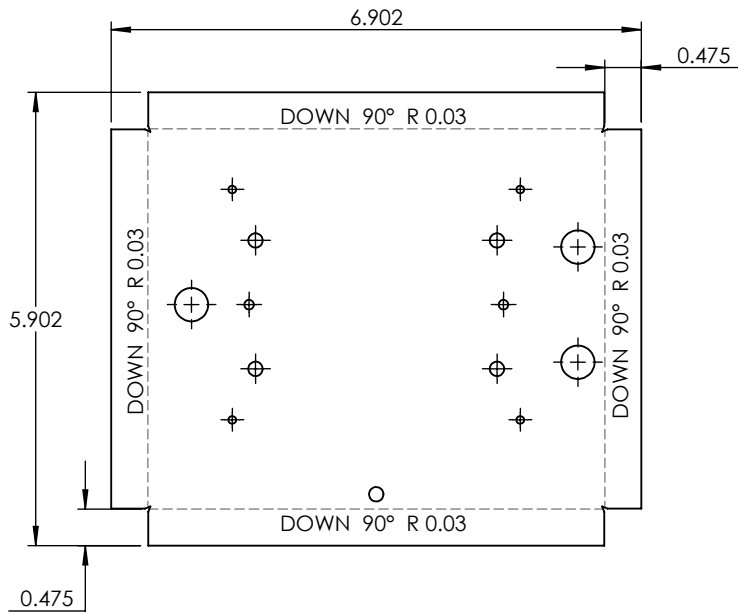
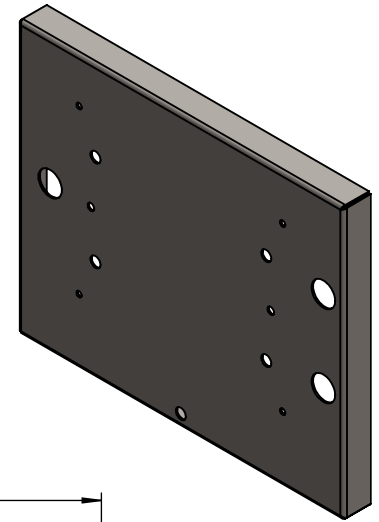

PROPRIETARY AND CONFIDENTIAL
 THE INFORMATION CONTAINED IN THIS DRAWING IS THE SOLE PROPERTY OF <INSERT COMPANY NAME HERE>. ANY REPRODUCTION IN PART OR AS A WHOLE WITHOUT THE WRITTEN PERMISSION OF <INSERT COMPANY NAME HERE> IS PROHIBITED.

		UNLESS OTHERWISE SPECIFIED:	NAME	DATE	22 GAUGE		
		DIMENSIONS ARE IN INCHES TOLERANCES: FRACTIONAL ± ANGULAR: MACH ± BEND ± TWO PLACE DECIMAL ± THREE PLACE DECIMAL ±	DRAWN				TITLE:
		INTERPRET GEOMETRIC TOLERANCING PER:	CHECKED		ACR-BX-W-14W-AB-WF-DIM-30K		
		MATERIAL	ENG APPR.				
		FINISH	MFG APPR.		SIZE	DWG. NO.	REV
NEXT ASSY	USED ON		Q.A.		A		
APPLICATION		DO NOT SCALE DRAWING	COMMENTS:			SCALE: 1:2.5	WEIGHT:

5

4

3

2

1

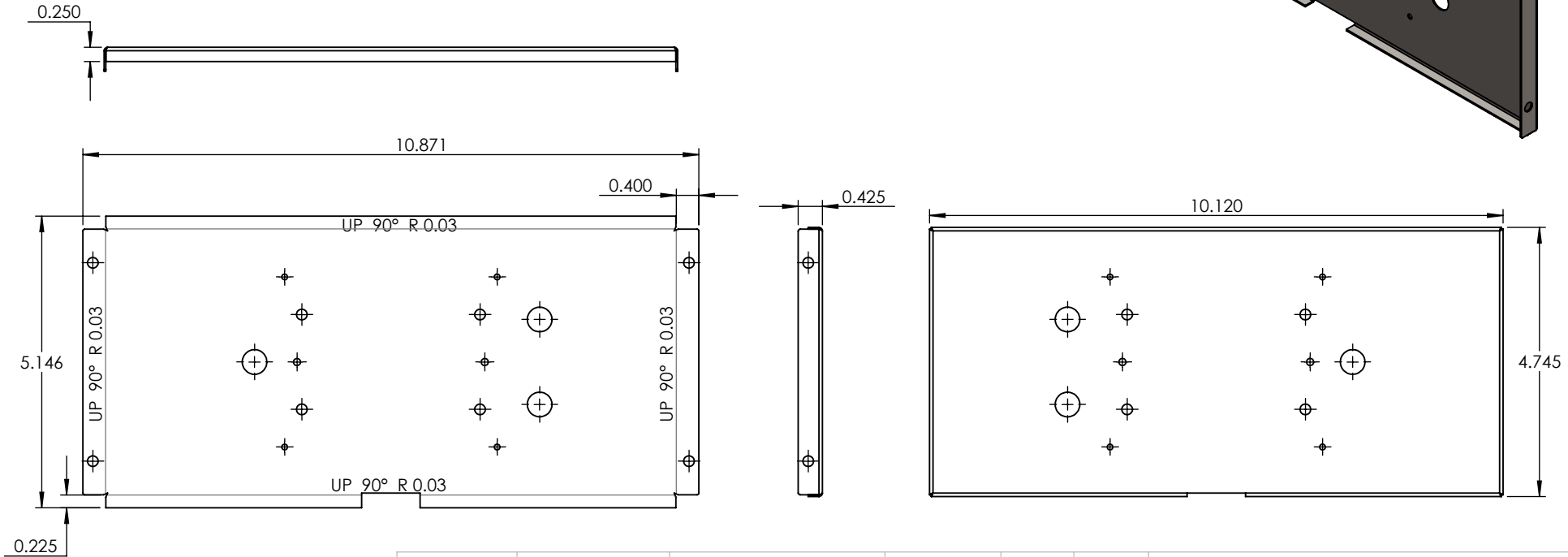
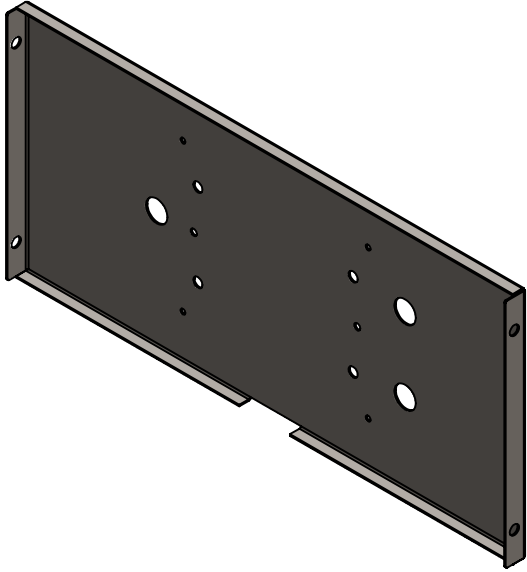

PROPRIETARY AND CONFIDENTIAL
 THE INFORMATION CONTAINED IN THIS DRAWING IS THE SOLE PROPERTY OF <INSERT COMPANY NAME HERE>. ANY REPRODUCTION IN PART OR AS A WHOLE WITHOUT THE WRITTEN PERMISSION OF <INSERT COMPANY NAME HERE> IS PROHIBITED.

		UNLESS OTHERWISE SPECIFIED:	NAME	DATE
		DIMENSIONS ARE IN INCHES	DRAWN	
		TOLERANCES:	CHECKED	
		FRACTIONAL ±	ENG APPR.	
		ANGULAR: MACH ± BEND ±	MFG APPR.	
		TWO PLACE DECIMAL ±	Q.A.	
		THREE PLACE DECIMAL ±	COMMENTS:	
		INTERPRET GEOMETRIC TOLERANCING PER:		
		MATERIAL		
NEXT ASSY	USED ON	FINISH		
APPLICATION		DO NOT SCALE DRAWING		

22 GAUGE		
TITLE:		
ACR-BX-W-14W-AB-WF-DIM-30K		
SIZE	DWG. NO.	REV
A		
SCALE: 1:2.75		SHEET 5 OF 7
WEIGHT:		

5

4

3

2

1

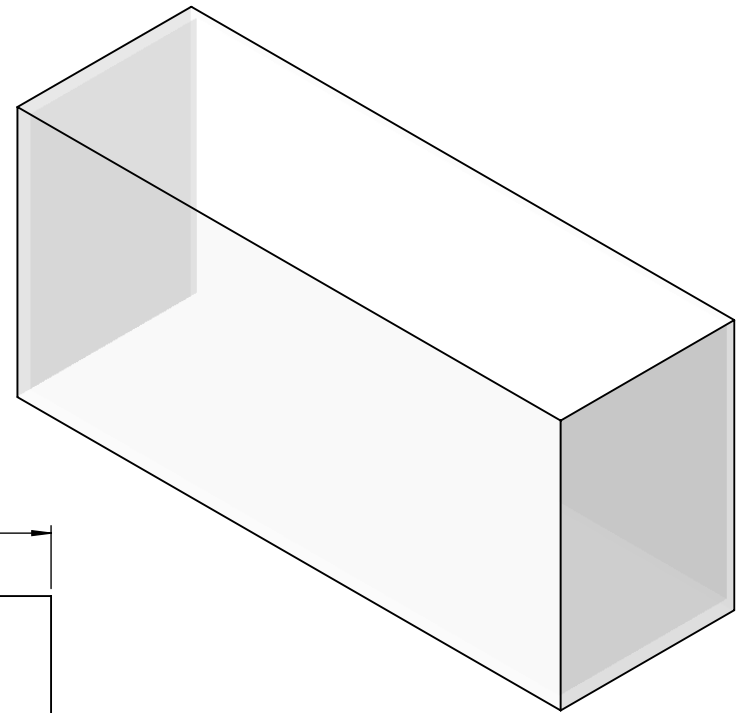
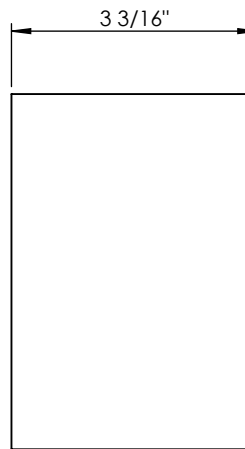
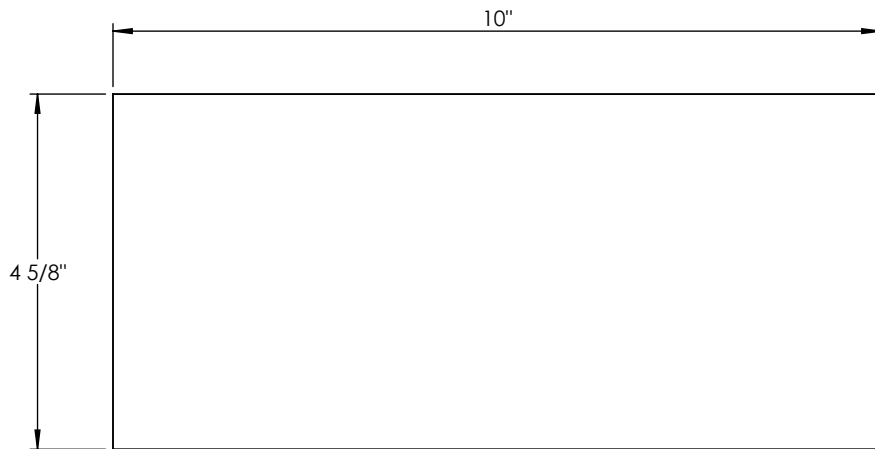

PROPRIETARY AND CONFIDENTIAL
 THE INFORMATION CONTAINED IN THIS DRAWING IS THE SOLE PROPERTY OF <INSERT COMPANY NAME HERE>. ANY REPRODUCTION IN PART OR AS A WHOLE WITHOUT THE WRITTEN PERMISSION OF <INSERT COMPANY NAME HERE> IS PROHIBITED.

		UNLESS OTHERWISE SPECIFIED:		NAME	DATE	ACRYLIC		
		DIMENSIONS ARE IN INCHES TOLERANCES: FRACTIONAL ± ANGULAR: MACH ± BEND ± TWO PLACE DECIMAL ± THREE PLACE DECIMAL ±	DRAWN					TITLE:
		INTERPRET GEOMETRIC TOLERANCING PER:	CHECKED			ACR-BX-W-14W-AB-WF-DIM-30K		
		MATERIAL	ENG APPR.			SIZE	DWG. NO.	REV
	NEXT ASSY	USED ON	MFG APPR.			A		
			Q.A.				SCALE: 1:2.5	WEIGHT:
	APPLICATION	DO NOT SCALE DRAWING	COMMENTS:					

5

4

3

2

1

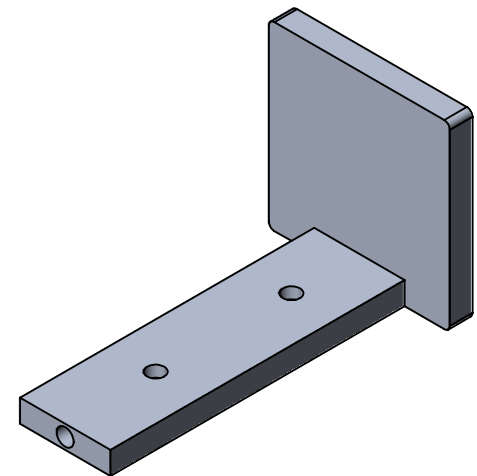
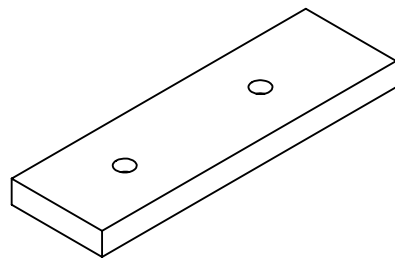
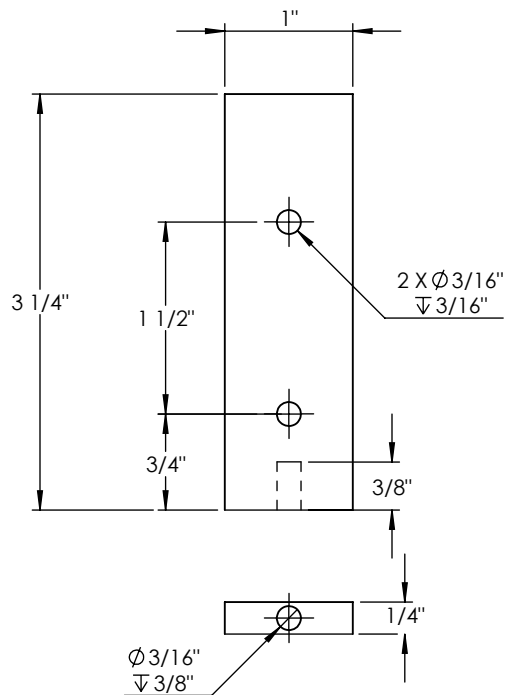
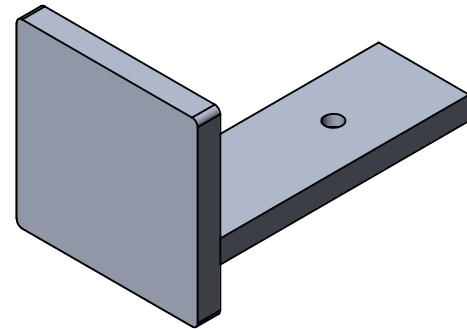
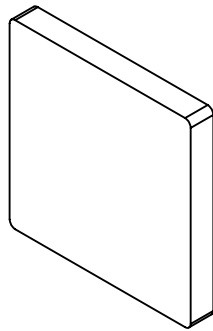
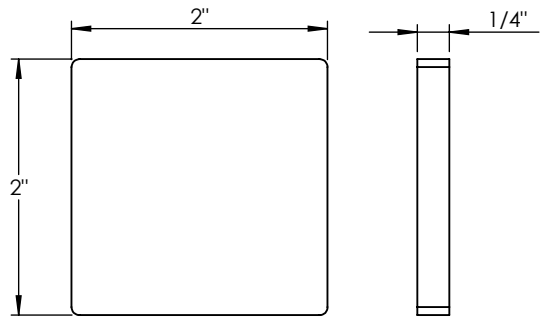

UNLESS OTHERWISE SPECIFIED:		NAME	DATE	1/4" ALUMINUM PLATE & 1/4"X1" ALUMINUM BAR	
DIMENSIONS ARE IN INCHES TOLERANCES: FRACTIONAL \pm ANGULAR: MACH \pm BEND \pm TWO PLACE DECIMAL \pm THREE PLACE DECIMAL \pm		DRAWN			
INTERPRET GEOMETRIC TOLERANCING PER:		CHECKED		ACR-BX-W-14W-AB-WF-DIM-30K	
		ENG APPR.			
MATERIAL		MFG APPR.		SIZE DWG. NO. REV	
		Q.A.		A	
FINISH		COMMENTS:		SCALE: 1:1.5 WEIGHT: SHEET 7 OF 7	
APPLICATION		DO NOT SCALE DRAWING			

PROPRIETARY AND CONFIDENTIAL
THE INFORMATION CONTAINED IN THIS DRAWING IS THE SOLE PROPERTY OF <INSERT COMPANY NAME HERE>. ANY REPRODUCTION IN PART OR AS A WHOLE WITHOUT THE WRITTEN PERMISSION OF <INSERT COMPANY NAME HERE> IS PROHIBITED.