

ITEM NO.	PART NUMBER	DESCRIPTION	QTY.	CUT
1	2500-W-10"-8W-TBR-CFA-MMS-30K-TOP	22 GAUGE	1	
2	2500-W-10"-8W-TBR-CFA-MMS-30K-TOP FRAME	22 GAUGE	1	
3	2500-W-10"-8W-TBR-CFA-MMS-30K-TOP FRAME SIDE	22 GAUGE	2	
4	2500-W-10"-8W-TBR-CFA-MMS-30K-DOOR BRACKET	22 GAUGE	1	
5	2500-W-10"-8W-TBR-CFA-MMS-30K-DOOR	22 GAUGE	1	
6	2500-W-10"-8W-TBR-CFA-MMS-30K-BACKPLATE	22 GAUGE	1	
7	2500-W-10"-8W-TBR-CFA-MMS-30K-LED BRACKET	22 GAUGE	1	
8	2500-W-10"-8W-TBR-CFA-MMS-30K-ACRYLIC	ACRYLIC	1	
9	EspenTECH_120277V_SKU808076	DRIVER	1	
10	AlfaLED_PN1011_RevB	LED	2	
11	LEVITON OSM3D-DDW	SENSOR	1	

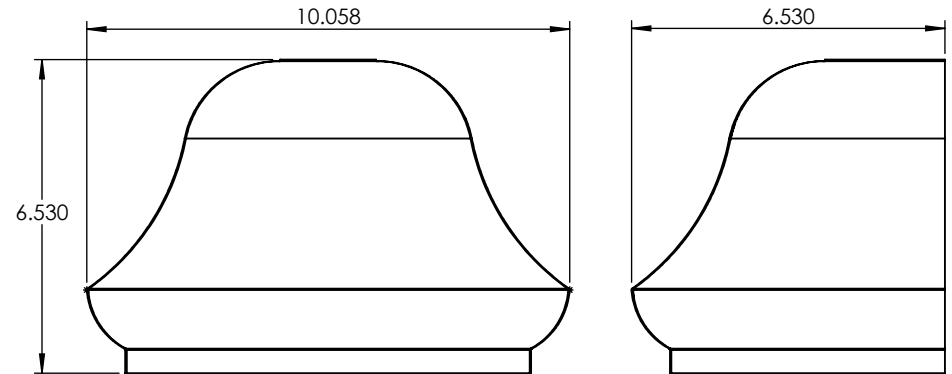
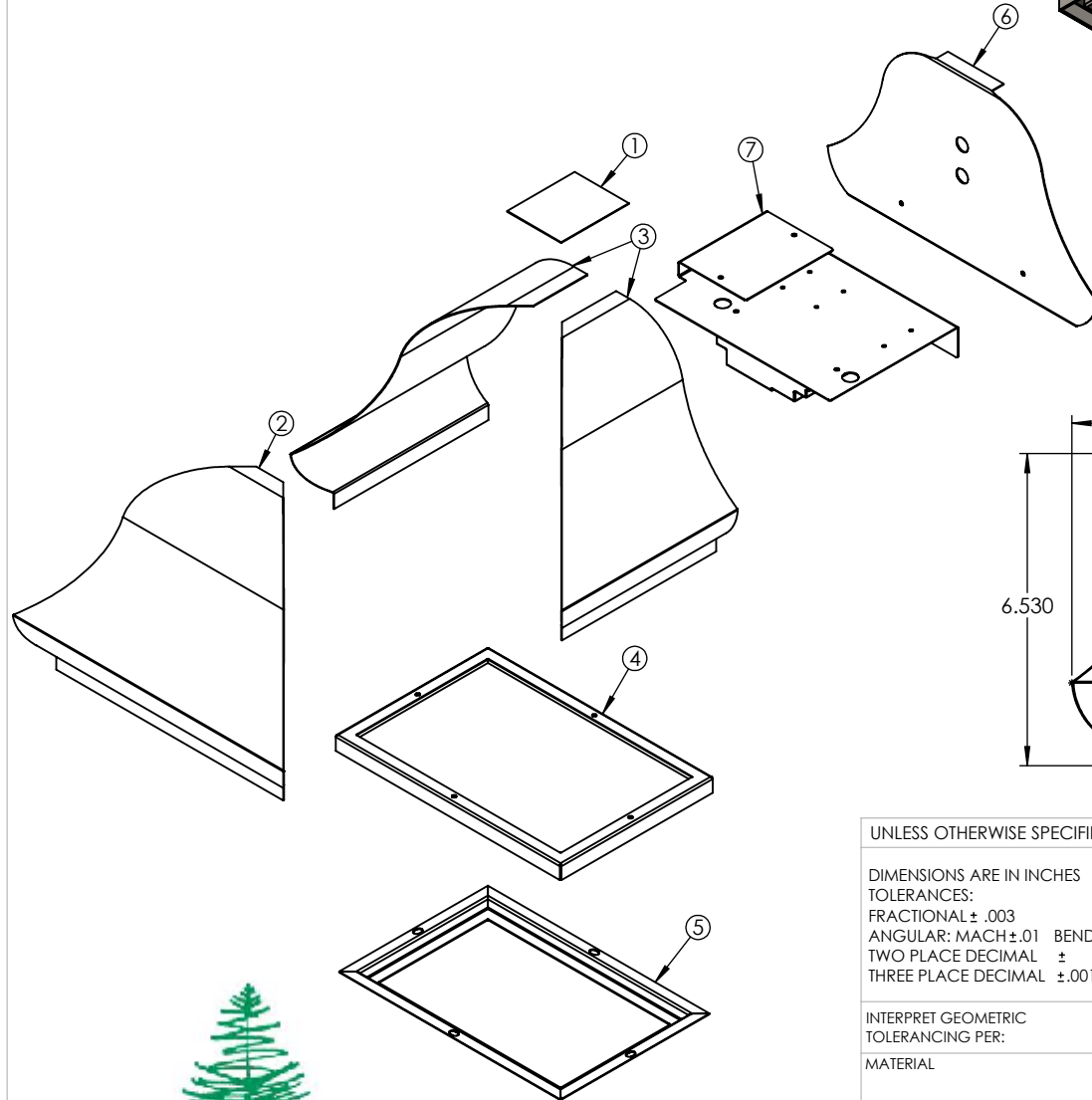
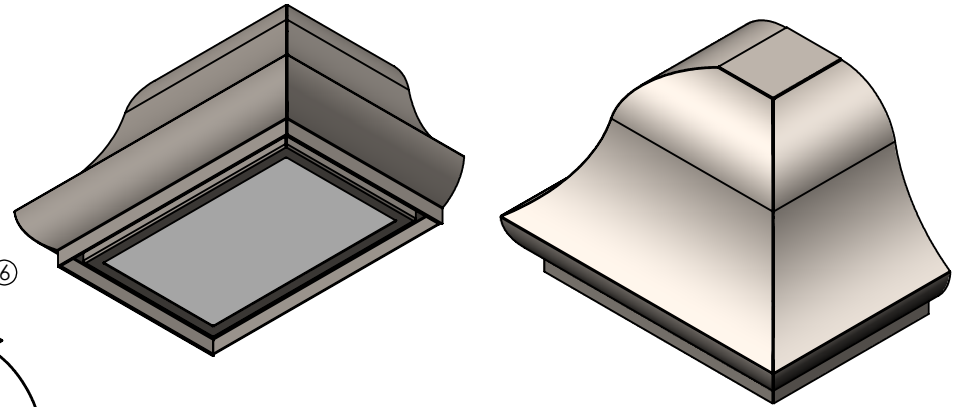

ALL BEND RADIUS .030"

APPLICATION

DO NOT SCALE DRAWING

UNLESS OTHERWISE SPECIFIED:

DIMENSIONS ARE IN INCHES
 TOLERANCES:
 FRACTIONAL $\pm .003$
 ANGULAR: MACH $\pm .01$ BEND \pm
 TWO PLACE DECIMAL \pm
 THREE PLACE DECIMAL $\pm .001$

INTERPRET GEOMETRIC
 TOLERANCING PER:

MATERIAL

FINISH

NAME

DATE

DRAWN

CHECKED

ENG APPR.

MFG APPR.

Q.A.

COMMENTS:

TITLE:

2500-W-10"-8W-TBR-CFA-MMS-30K

SIZE DWG. NO.

REV

A TICKET 25215

SCALE: 1:5

WEIGHT:

SHEET 1 OF 7

5

4

3

2

1

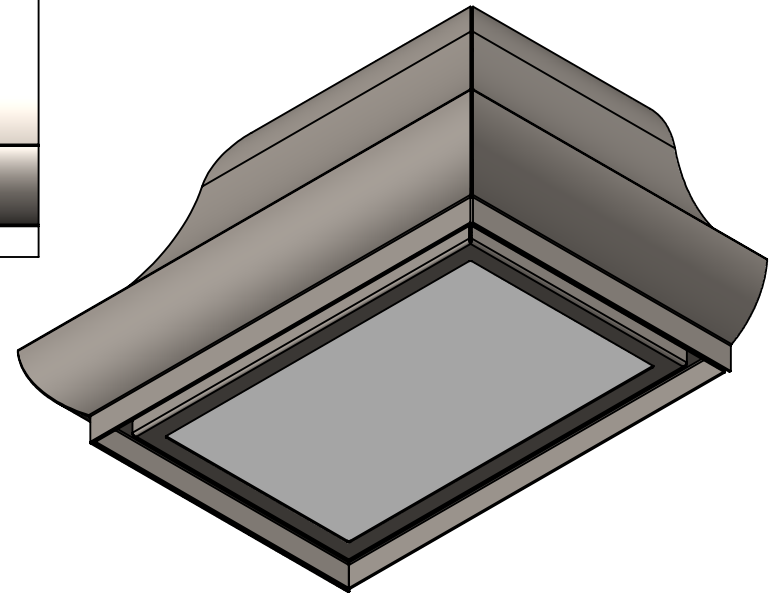
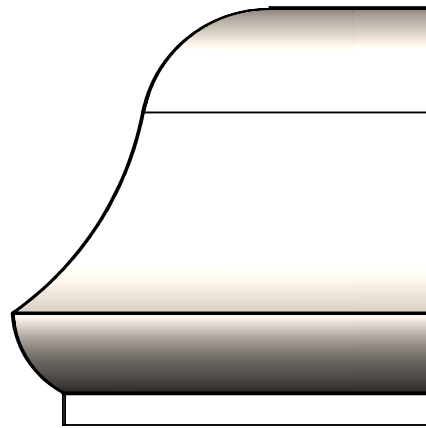
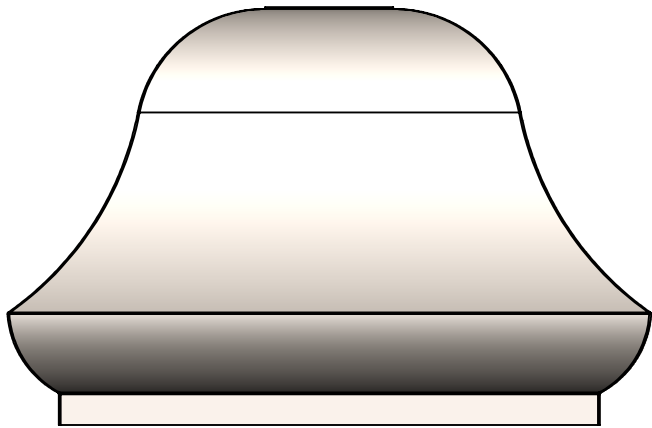
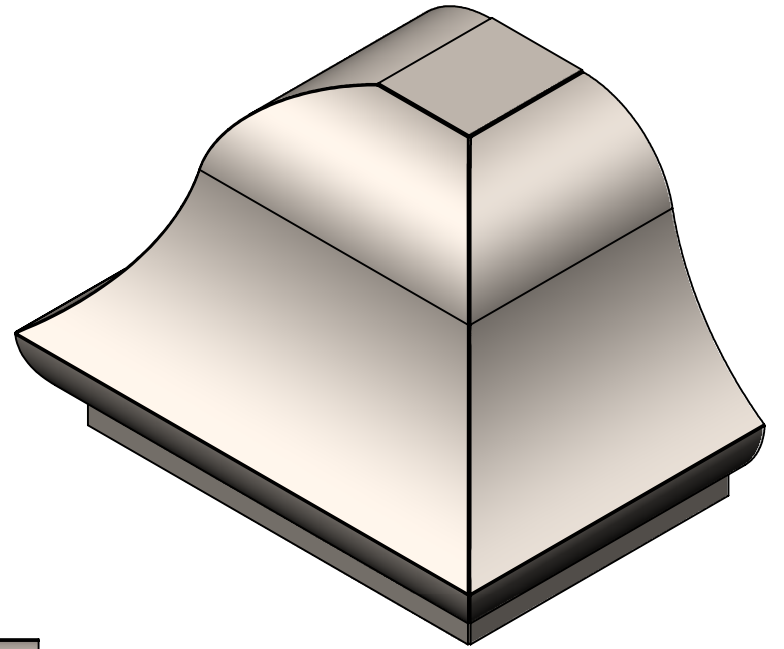
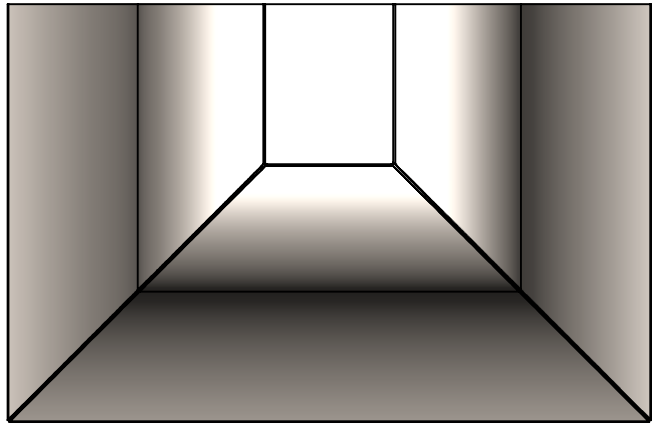

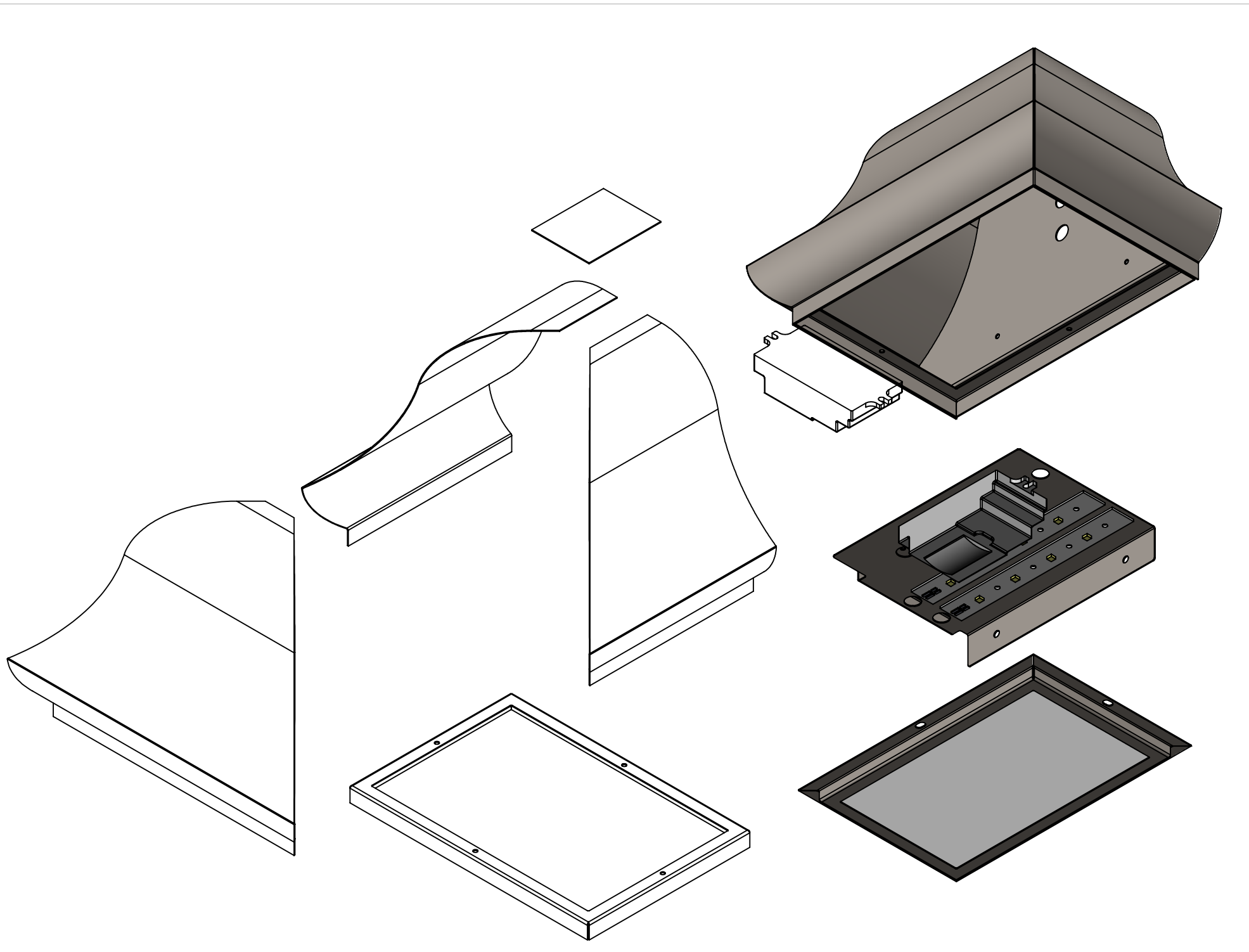

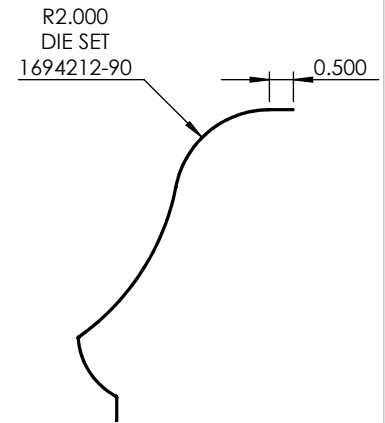
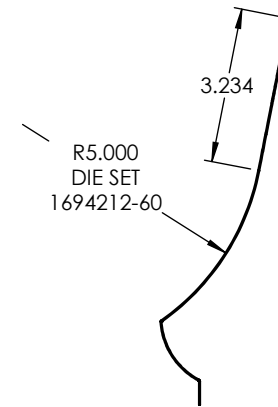
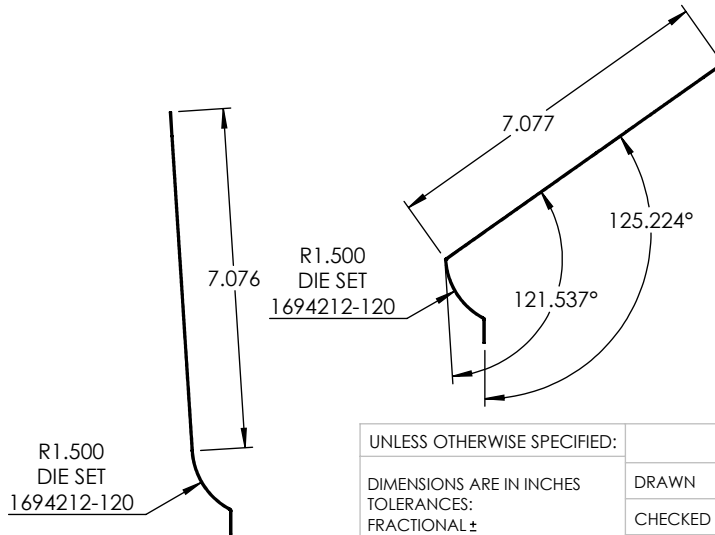
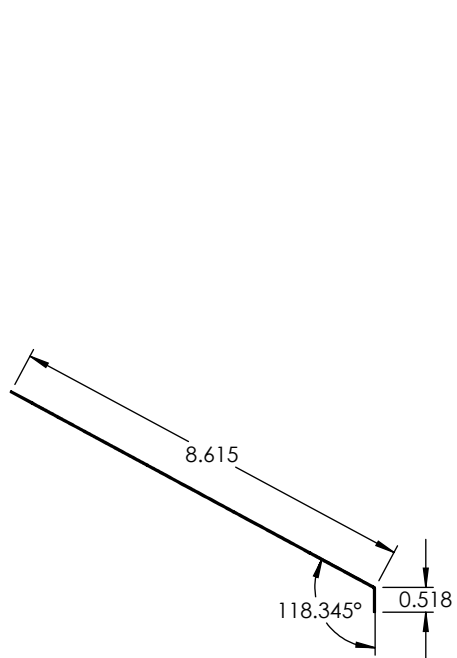
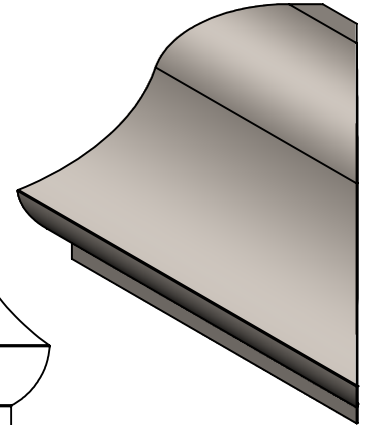
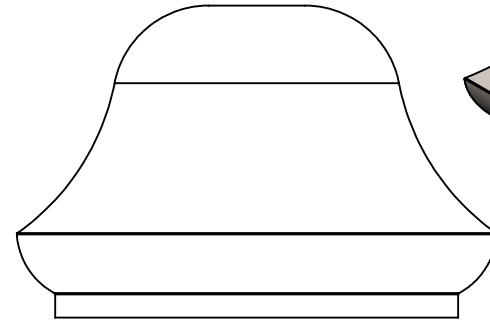
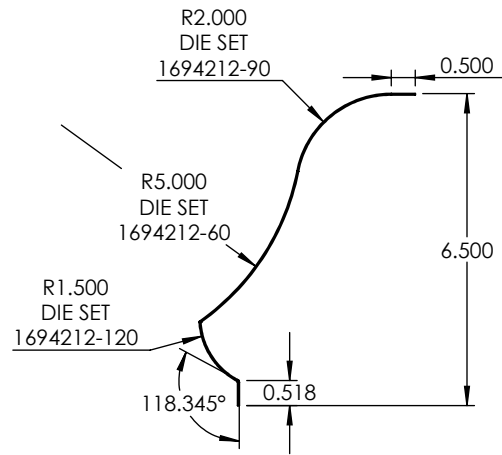
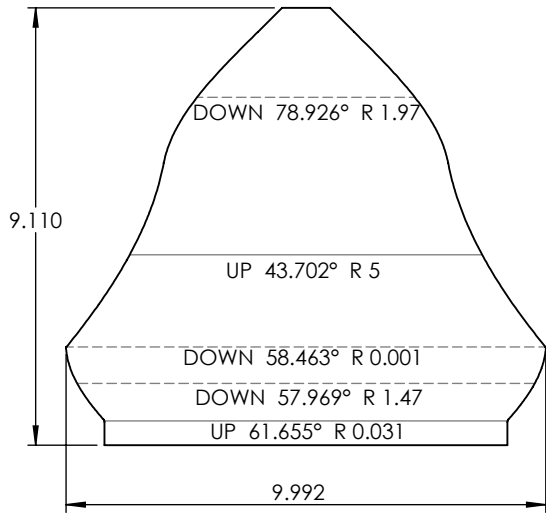

UNLESS OTHERWISE SPECIFIED:

DIMENSIONS ARE IN INCHES
 TOLERANCES:
 FRACTIONAL: ±
 ANGULAR: MACH ± BEND ±
 TWO PLACE DECIMAL ±
 THREE PLACE DECIMAL ±

INTERPRET GEOMETRIC
 TOLERANCING PER:

MATERIAL

FINISH

DO NOT SCALE DRAWING

NAME DATE

DRAWN
 CHECKED
 ENG APPR.
 MFG APPR.

Q.A.
 COMMENTS:

22 GAUGE

TITLE:

2500-W-10"-8W-TBR-CFA-MMS-30K

SIZE
A

DWG. NO.

REV

SCALE: 1:4

WEIGHT:

SHEET 4 OF 7

PROPRIETARY AND CONFIDENTIAL
 THE INFORMATION CONTAINED IN THIS
 DRAWING IS THE SOLE PROPERTY OF
 <INSERT COMPANY NAME HERE>. ANY
 REPRODUCTION IN PART OR AS A WHOLE
 WITHOUT THE WRITTEN PERMISSION OF
 <INSERT COMPANY NAME HERE> IS
 PROHIBITED.

NEXT ASSY	USED ON
APPLICATION	

5

4

3

2

1

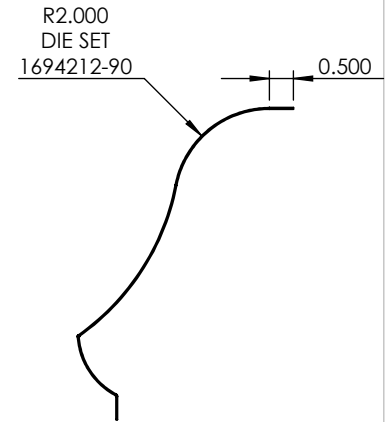
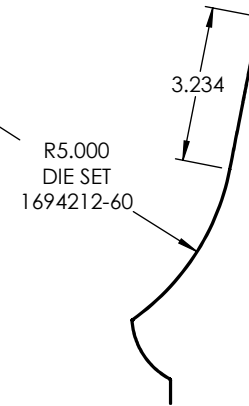
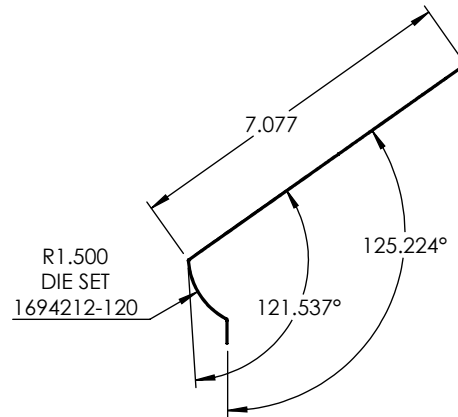
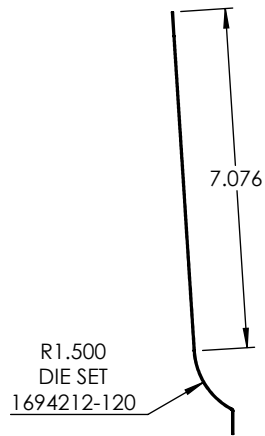
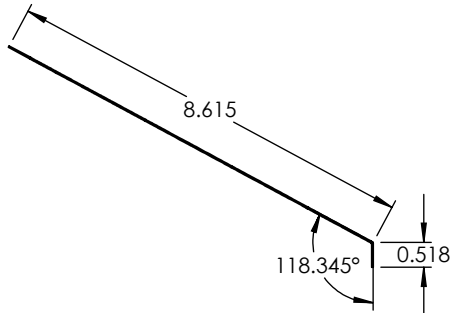
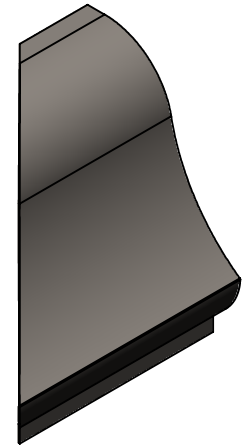
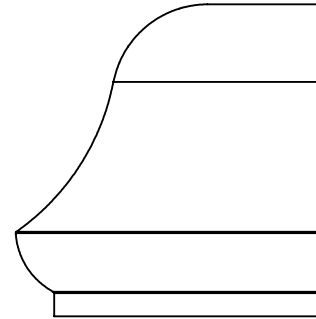
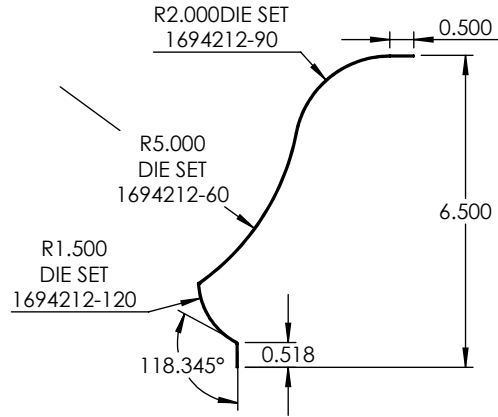
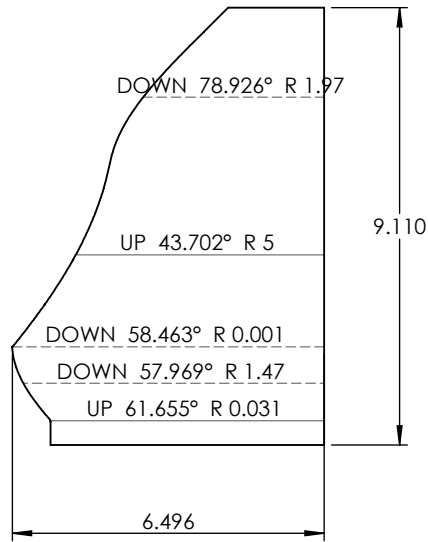

UNLESS OTHERWISE SPECIFIED:

DIMENSIONS ARE IN INCHES
 TOLERANCES:
 FRACTIONAL ±
 ANGULAR: MACH ± BEND ±
 TWO PLACE DECIMAL ±
 THREE PLACE DECIMAL ±

INTERPRET GEOMETRIC
 TOLERANCING PER:

MATERIAL

FINISH

DO NOT SCALE DRAWING

NAME

DATE

DRAWN

CHECKED

ENG APPR.

MFG APPR.

Q.A.

COMMENTS:

22 GAUGE

TITLE:

2500-W-10"-8W-TBR-CFA-MMS-30K

SIZE
A

DWG. NO.

REV

SCALE: 1:4

WEIGHT:

SHEET 5 OF 7

PROPRIETARY AND CONFIDENTIAL
 THE INFORMATION CONTAINED IN THIS
 DRAWING IS THE SOLE PROPERTY OF
 <INSERT COMPANY NAME HERE>. ANY
 REPRODUCTION IN PART OR AS A WHOLE
 WITHOUT THE WRITTEN PERMISSION OF
 <INSERT COMPANY NAME HERE> IS
 PROHIBITED.

NEXT ASSY	USED ON
APPLICATION	

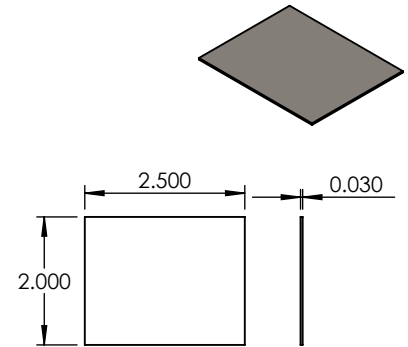
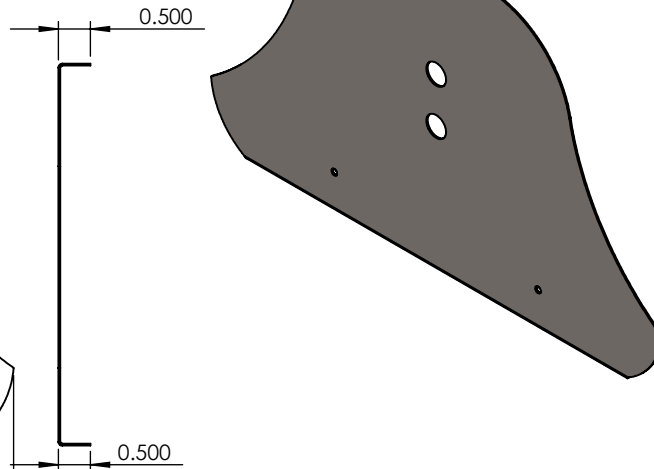
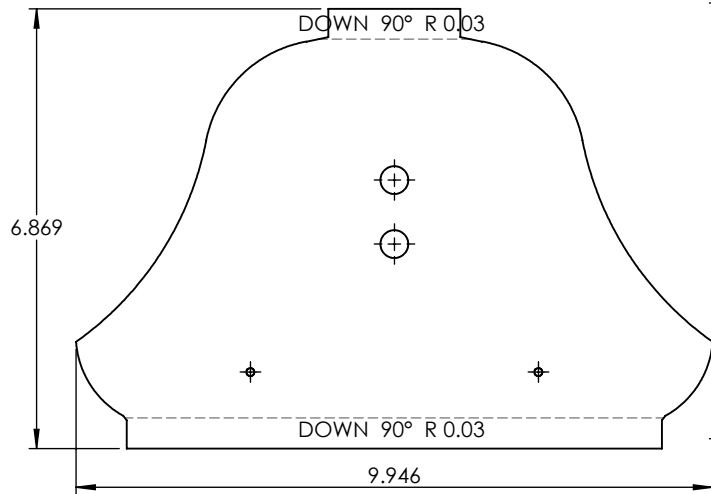
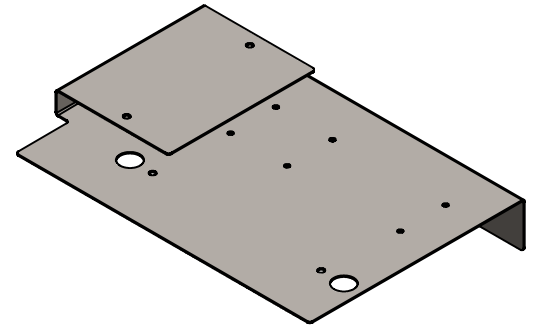
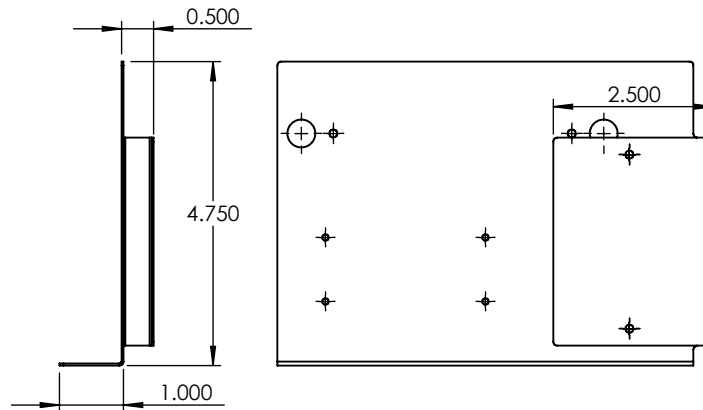
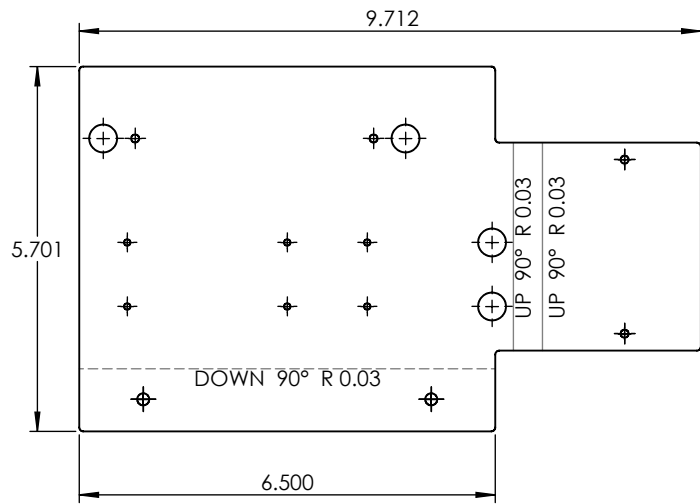

UNLESS OTHERWISE SPECIFIED:

DIMENSIONS ARE IN INCHES
 TOLERANCES:
 FRACTIONAL ±
 ANGULAR: MACH ± BEND ±
 TWO PLACE DECIMAL ±
 THREE PLACE DECIMAL ±

INTERPRET GEOMETRIC
 TOLERANCING PER:

MATERIAL

FINISH

DO NOT SCALE DRAWING

NAME DATE

DRAWN
 CHECKED
 ENG APPR.
 MFG APPR.

Q.A.

COMMENTS:

22 GAUGE

TITLE:

2500-W-10"-8W-TBR-CFA-MMS-30K

SIZE DWG. NO.

REV

SCALE: 1:3 WEIGHT:

SHEET 6 OF 7

PROPRIETARY AND CONFIDENTIAL
 THE INFORMATION CONTAINED IN THIS
 DRAWING IS THE SOLE PROPERTY OF
 <INSERT COMPANY NAME HERE>. ANY
 REPRODUCTION IN PART OR AS A WHOLE
 WITHOUT THE WRITTEN PERMISSION OF
 <INSERT COMPANY NAME HERE> IS
 PROHIBITED.

NEXT ASSY

USED ON

APPLICATION

5

4

3

2

1

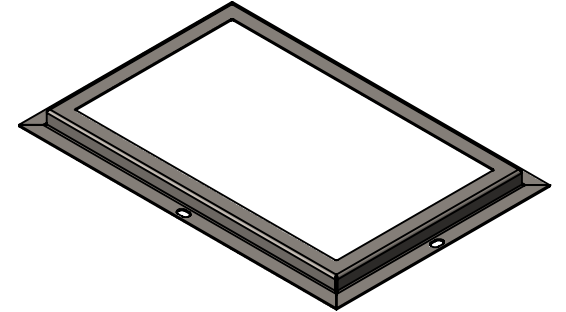
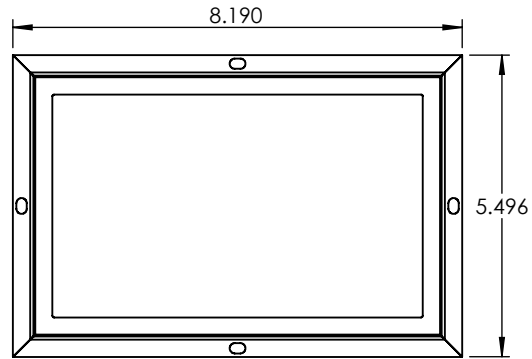
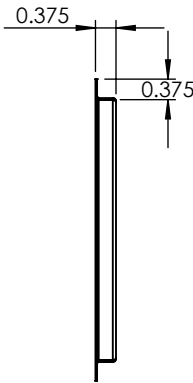
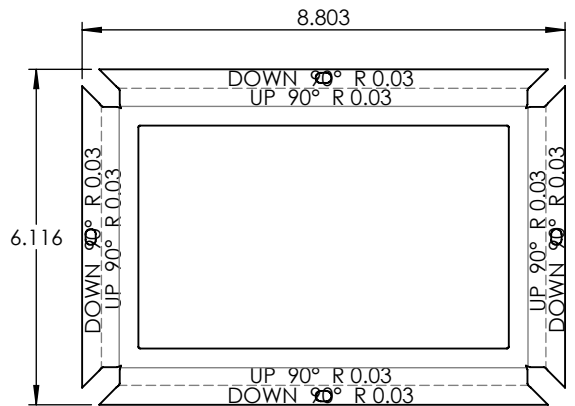
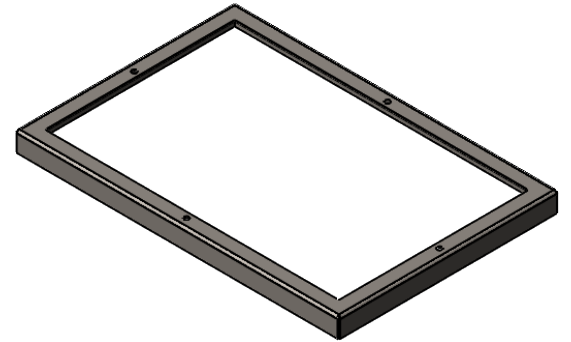
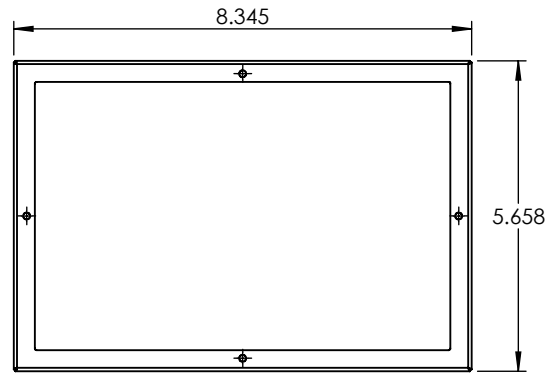
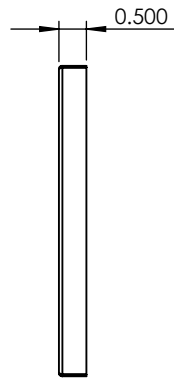
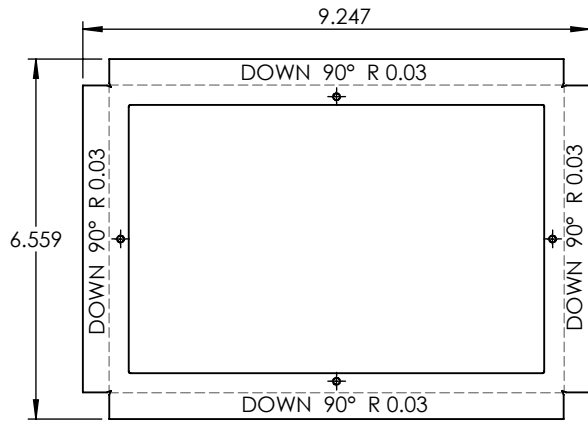

PROPRIETARY AND CONFIDENTIAL
 THE INFORMATION CONTAINED IN THIS DRAWING IS THE SOLE PROPERTY OF <INSERT COMPANY NAME HERE>. ANY REPRODUCTION IN PART OR AS A WHOLE WITHOUT THE WRITTEN PERMISSION OF <INSERT COMPANY NAME HERE> IS PROHIBITED.

		UNLESS OTHERWISE SPECIFIED:	NAME	DATE
		DIMENSIONS ARE IN INCHES TOLERANCES: FRACTIONAL ± ANGULAR: MACH ± BEND ± TWO PLACE DECIMAL ± THREE PLACE DECIMAL ±	DRAWN	
		INTERPRET GEOMETRIC TOLERANCING PER:	CHECKED	
		MATERIAL	ENG APPR.	
		FINISH	MFG APPR.	
NEXT ASSY	USED ON		Q.A.	
APPLICATION	DO NOT SCALE DRAWING		COMMENTS:	

22 GAUGE		
TITLE: 2500-W-10"-8W-TBR-CFA-MMS-30K		
SIZE A	DWG. NO.	REV
SCALE: 1:3.5WEIGHT:		SHEET 7 OF 7