

ITEM NO.	PART NUMBER	DESCRIPTION	QTY.	CUT
1	AQR10-L12-A180-2-L-NL-MN-41K-SPUN SPHERE	SPUN ALUMINUM 0.080"	1	
2	AQR10-L12-A180-2-L-NL-MN-41K-CYLINDER BODY	CONCRETE BODY	1	
3	AQR10-L12-A180-2-L-NL-MN-41K-SPUN COVER	SPUN ALUMINUM 0.080"	1	
4	AQR10-L12-A180-2-L-NL-MN-41K-4.5" LENS BRACKET	SPUN ALUMINUM 0.080"	2	
5	AQR10-L12-A180-2-L-NL-MN-41K-HORIZONTAL LOUVER	SPUN ALUMINUM 0.0635"	5	
6	AQR10-L12-A180-2-L-NL-MN-41K-ANCHOR PLATE	ALUMINUM 0.500" PLATE	1	
7	AQR10-L12-A180-2-L-NL-MN-41K-8" SPHERE PLATE	ALUMINUM 0.125" PLATE	1	
8	AQR10-L12-A180-2-L-NL-MN-41K-LOUVER PLATE BOTTOM	ALUMINUM 0.125" PLATE	1	
9	AQR10-L12-A180-2-L-NL-MN-41K-DRIVER BRACKET	ALUMINUM 0.0635"	1	
10	AQR10-L12-A180-2-L-NL-MN-41K-TUBE BRACKET	ALUMINUM 0.0635"	1	
11	AQR10-L12-A180-2-L-NL-MN-41K-LOUVER ROLLED SHIELD	22 GAUGE	1	
12	AQR10-L12-A180-2-L-NL-MN-41K-SQUARE TUBE	1" SQUARE ALUMINUM TUBE	1	
13	AQR10-L12-A180-2-L-NL-MN-41K-ACRYLIC	ACRYLIC	1	
14	AQR10-L12-A180-2-L-NL-MN-41K-THREADED ROD	1/4" THREADED ROD	4	
15	AQR10-L12-A180-2-L-NL-MN-41K-0.5" REFLECTOR SPACER	3/8" ALUMINUM CYLINDER	16	
16	Espen VEL19070MVH-1	DRIVER	1	
17	AlfaLED PN1012 RevD	LED	4	

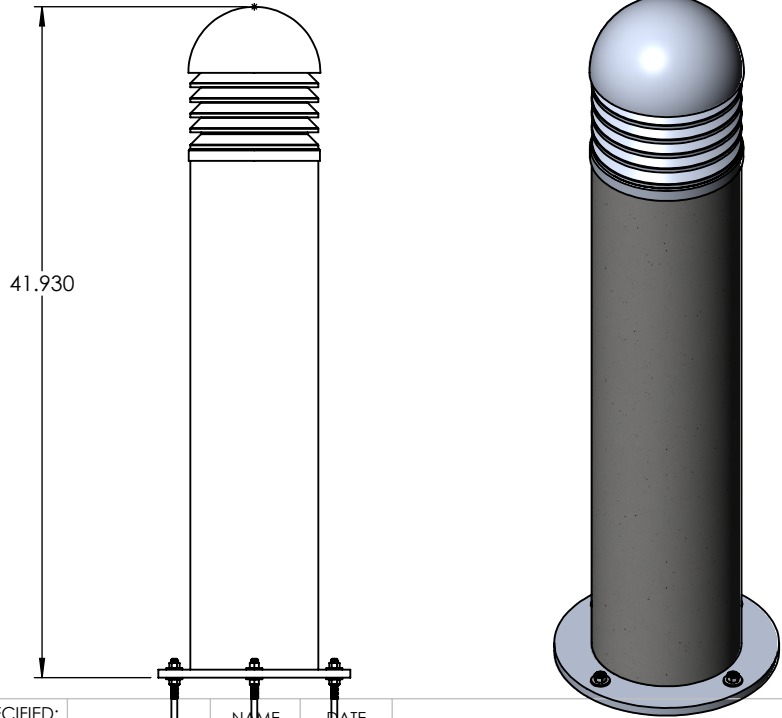

ALL BEND RADIUS .030"

UNLESS OTHERWISE SPECIFIED:

DIMENSIONS ARE IN INCHES
 TOLERANCES:
 FRACTIONAL ± .003
 ANGULAR: MACH ± .01 BEND ±
 TWO PLACE DECIMAL ±
 THREE PLACE DECIMAL ± .001

INTERPRET GEOMETRIC TOLERANCING PER:

MATERIAL

FINISH

DO NOT SCALE DRAWING

	NAME	DATE
DRAWN		
CHECKED		
ENG APPR.		
MFG APPR.		

Q.A.

COMMENTS:

TITLE:

AQR10-L12-A180-2-L-NL-MN-41K

SIZE DWG. NO. REV
A TICKET 25089

SCALE: 1:10 WEIGHT: SHEET 1 OF 13

5

4

3

2

1



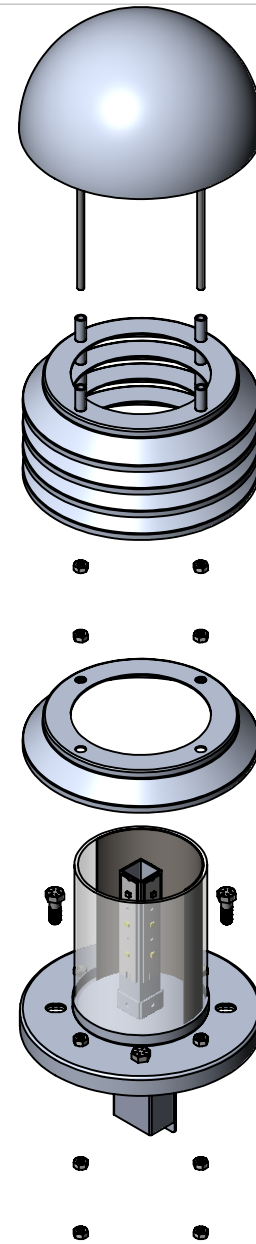
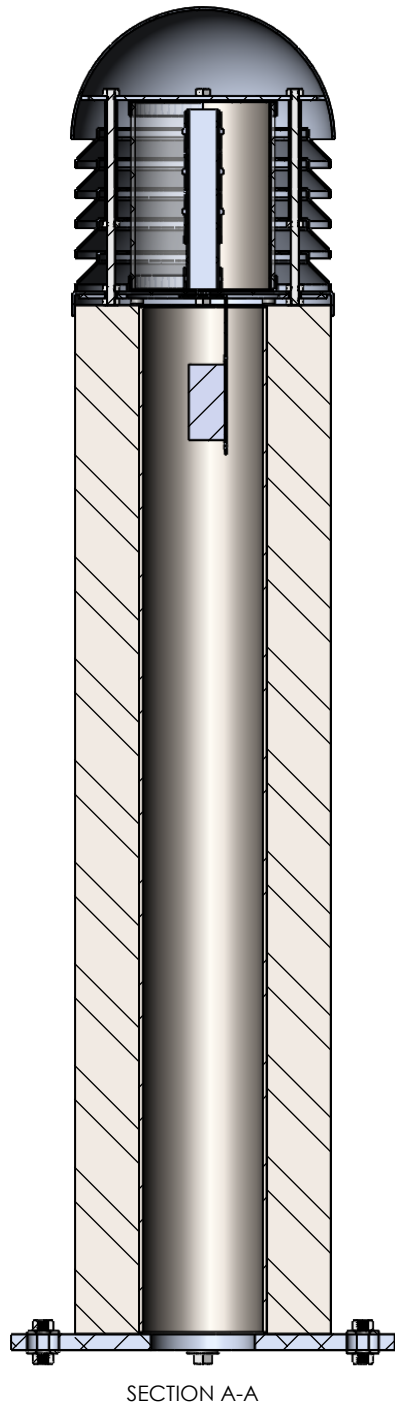

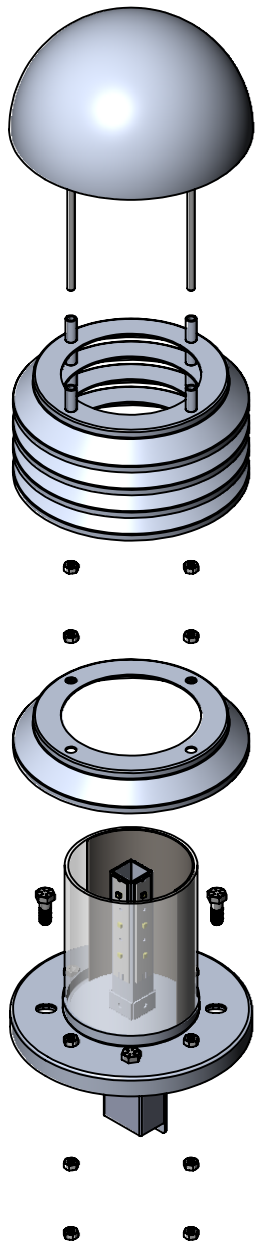

BOTTOM LOUVER IS LOOSE
TO ALLOW BOLTING TO BODY

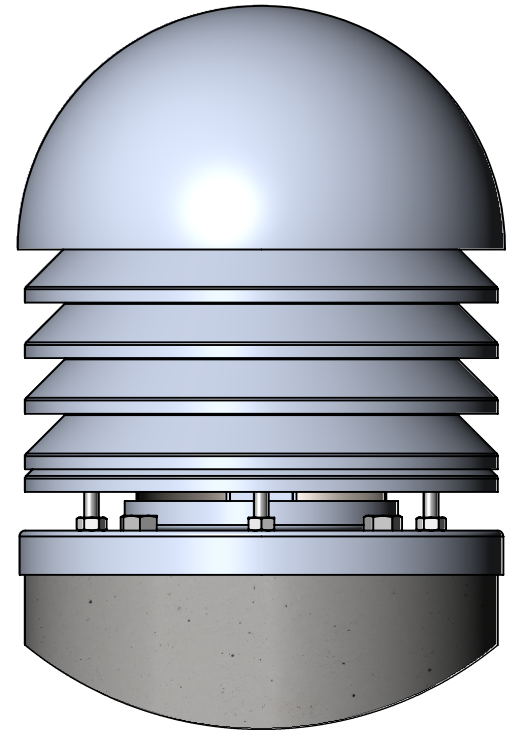
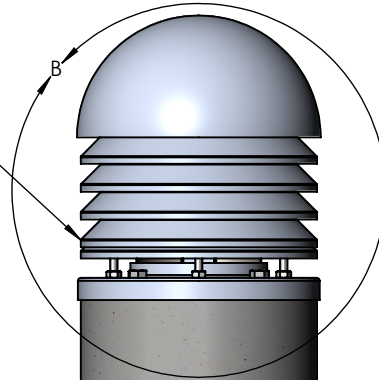

DETAIL B
SCALE 2 : 6.5

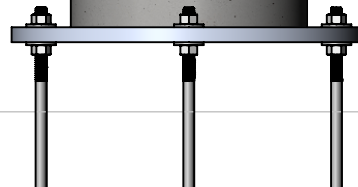

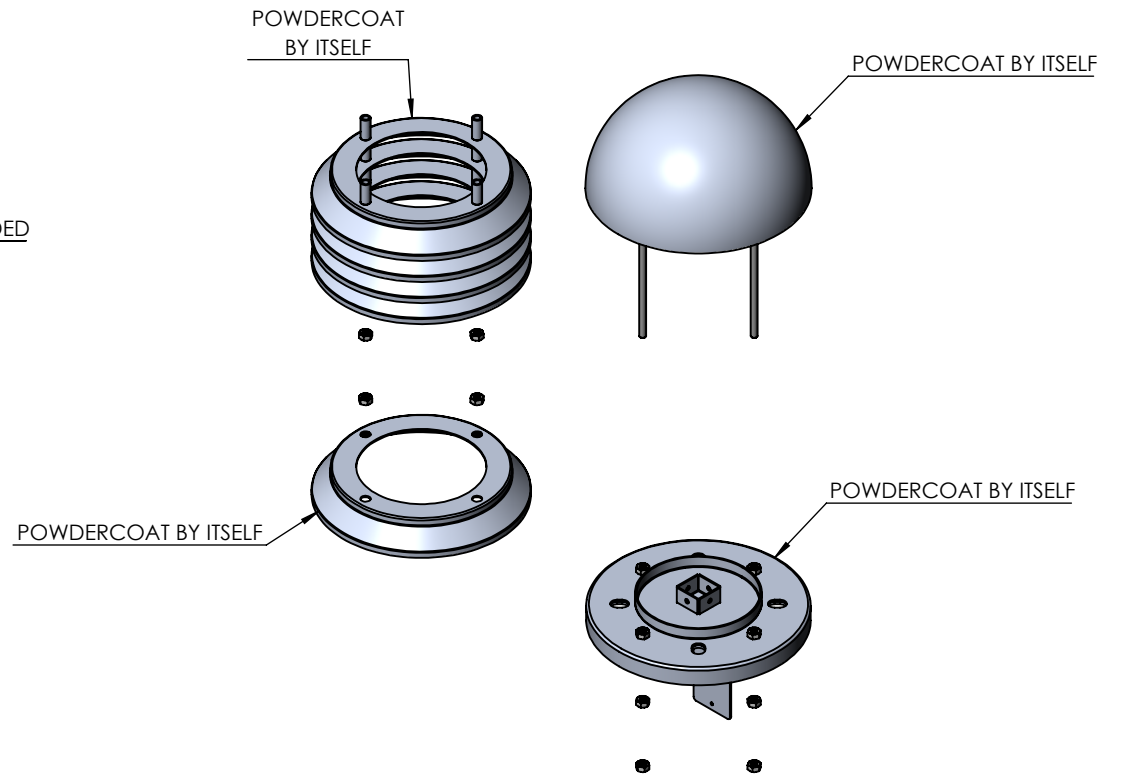
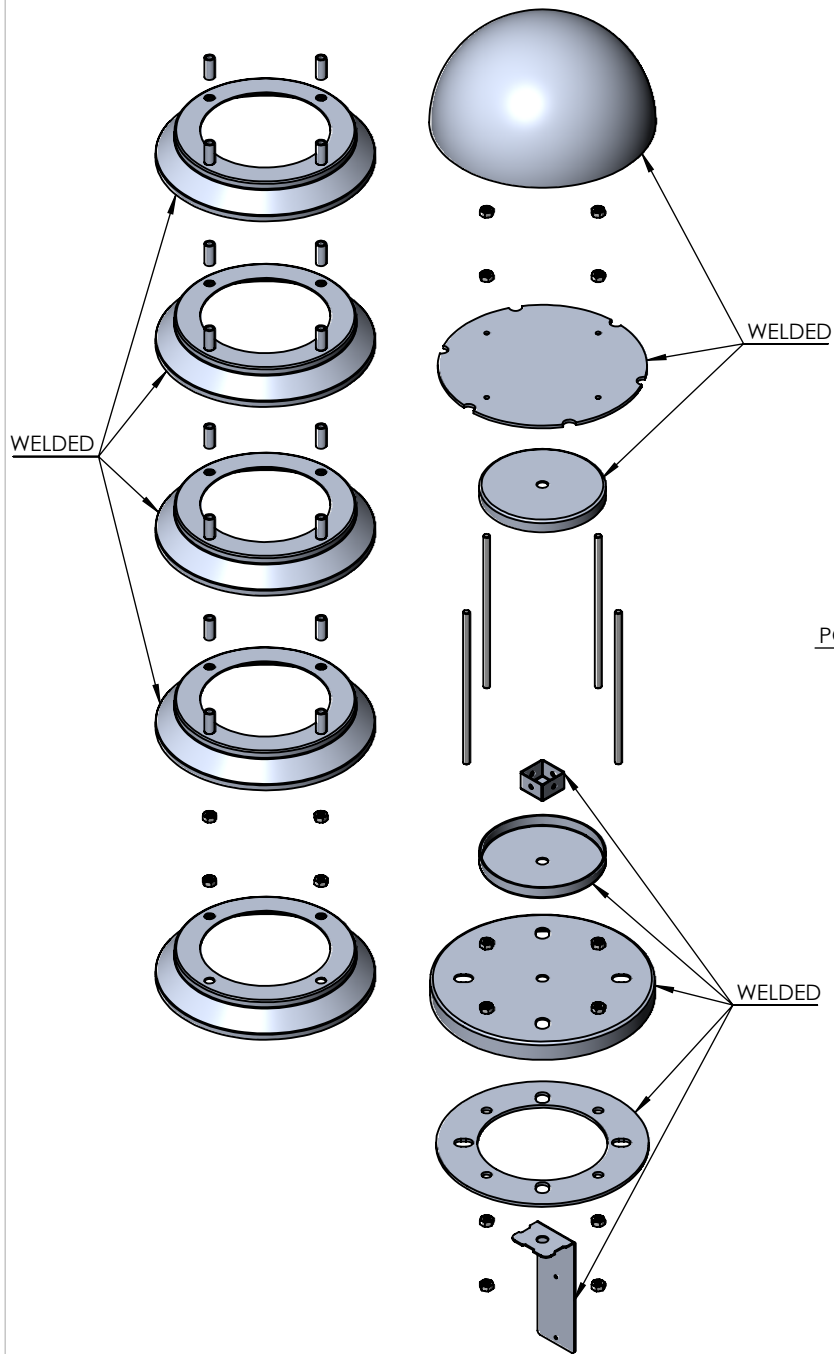

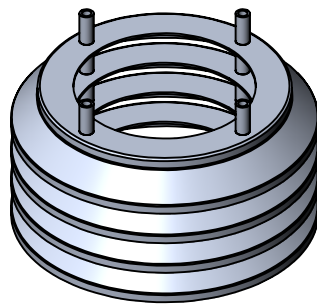
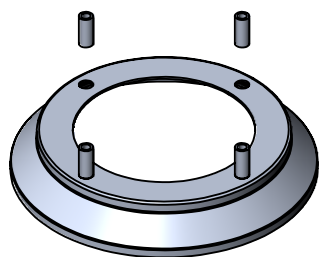
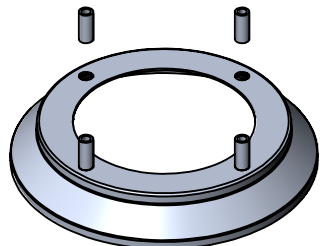
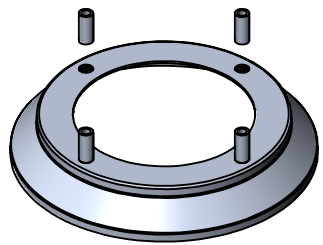
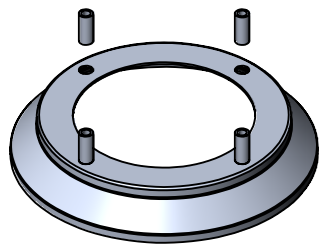

USE NUTS TO HOLD LOUVER
SUBASSEMBLY INTO PLATE

BOTTOM LOUVER IS LOOSE
TO ALLOW BOLTING TO BODY

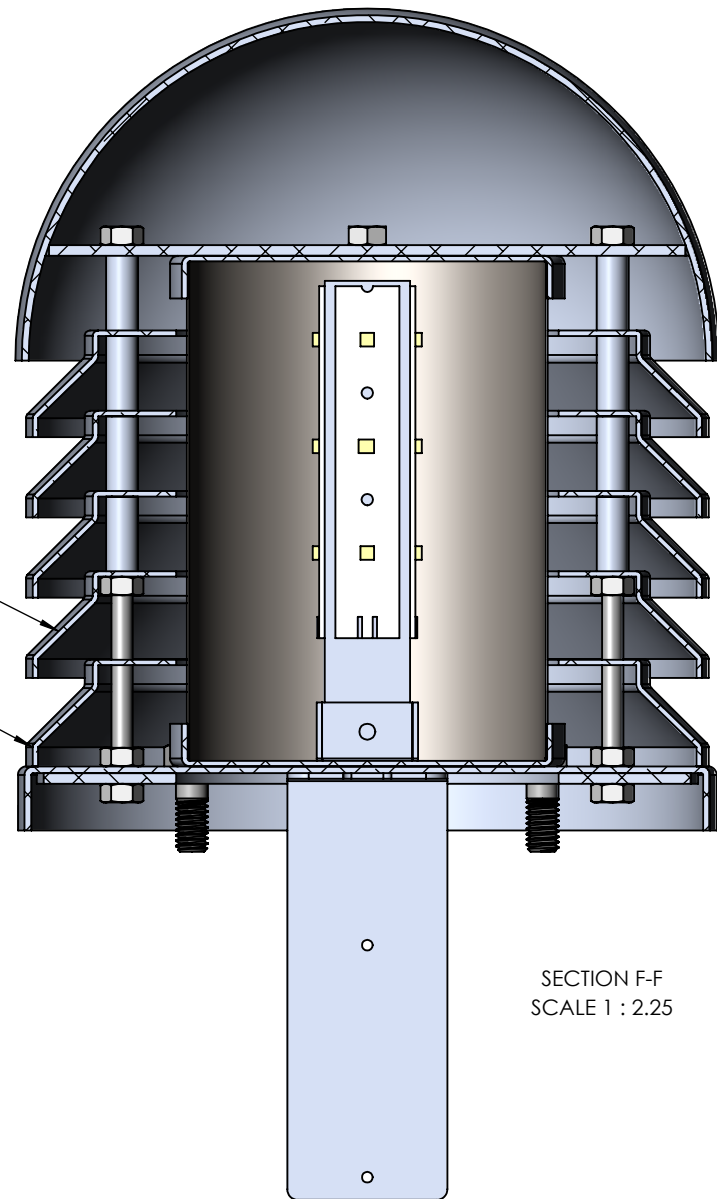
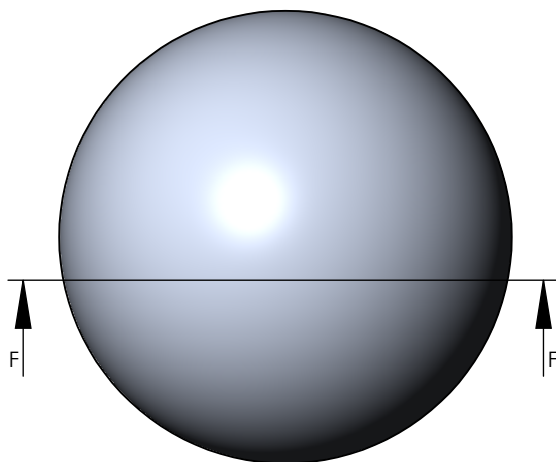

SECTION F-F
SCALE 1 : 2.25

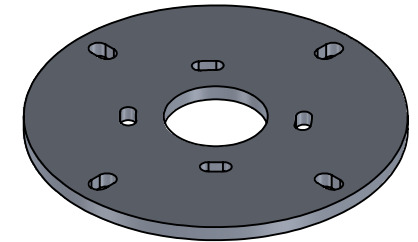
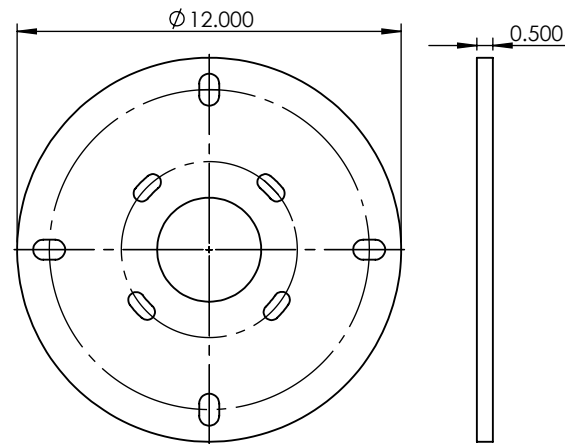
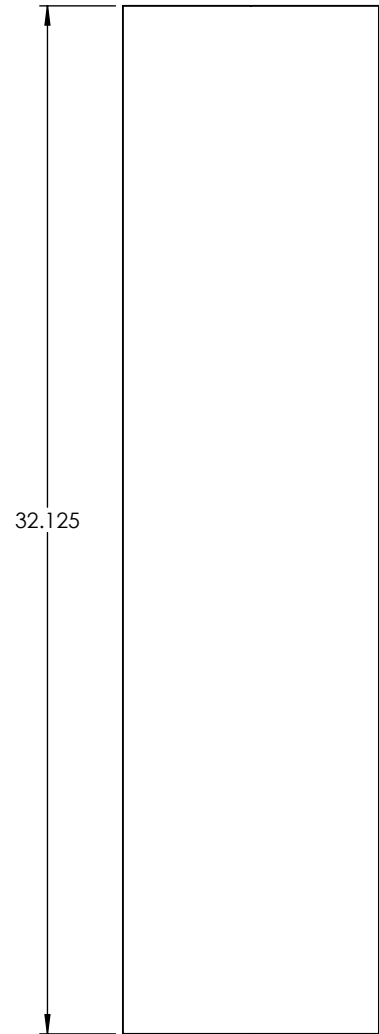
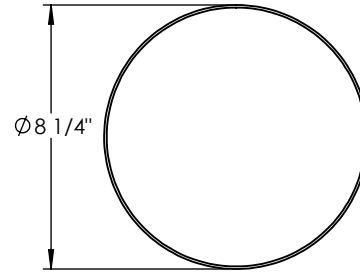
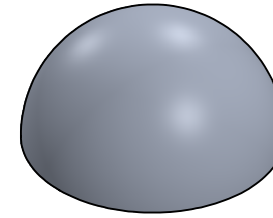
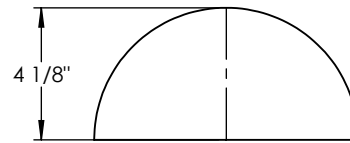
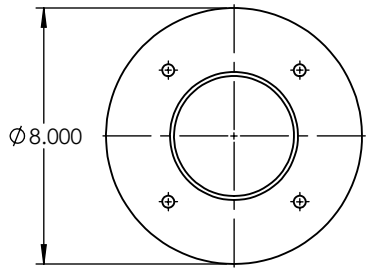

UNLESS OTHERWISE SPECIFIED:		NAME	DATE	ALUMINUM 0.500" PLATE	
DIMENSIONS ARE IN INCHES		DRAWN		TITLE:	
TOLERANCES:		CHECKED		AQR10-L12-A180-2-L-NL-MN-41K	
FRACTIONAL \pm		ENG APPR.		SIZE	DWG. NO.
ANGULAR: MACH \pm BEND \pm		MFG APPR.		A	REV
TWO PLACE DECIMAL \pm		Q.A.		SCALE: 1:6	WEIGHT:
THREE PLACE DECIMAL \pm		COMMENTS:		SHEET 7 OF 13	
INTERPRET GEOMETRIC TOLERANCING PER:					
MATERIAL					
FINISH					
DO NOT SCALE DRAWING					

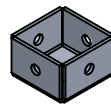
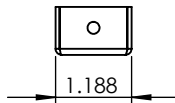
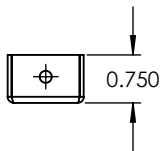
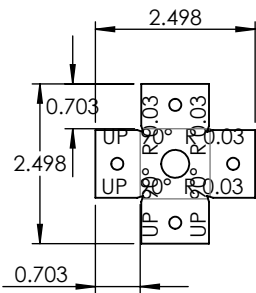
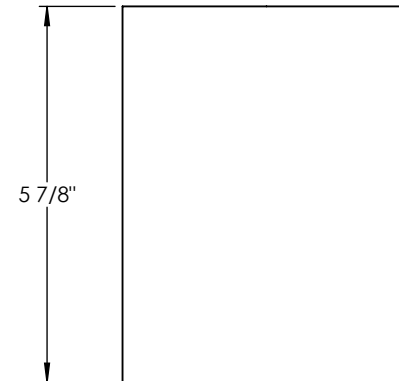
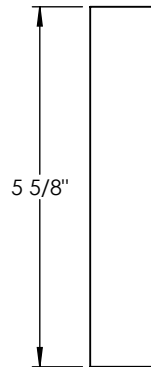
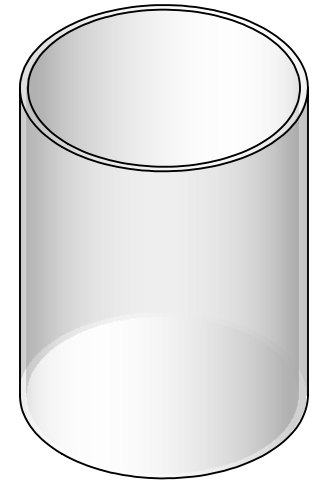
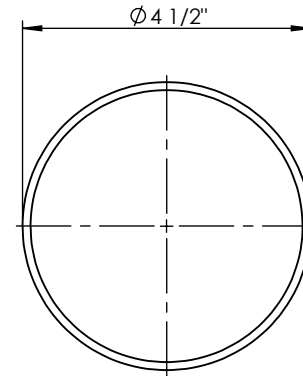
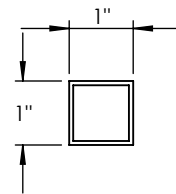
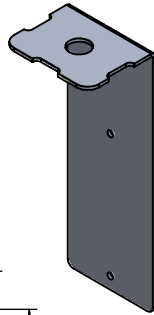
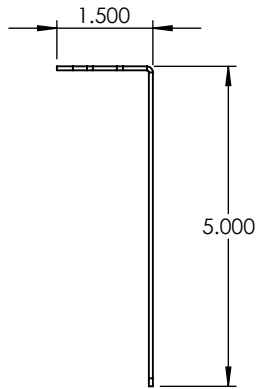
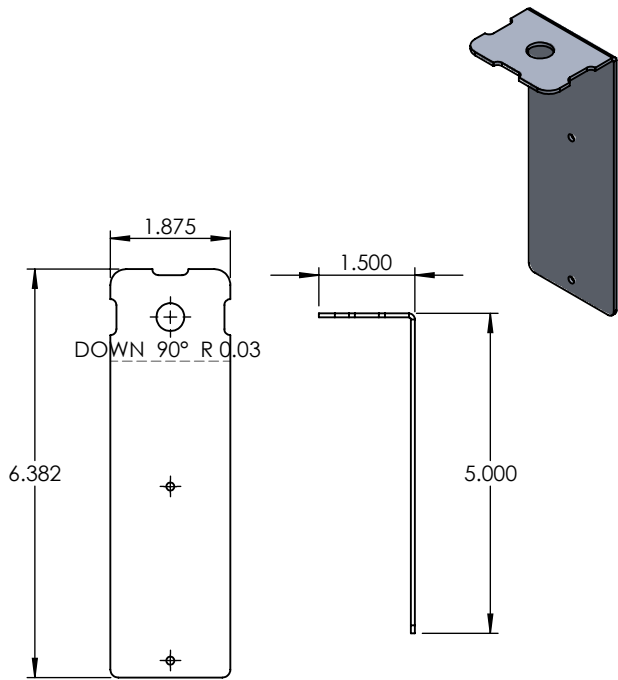

UNLESS OTHERWISE SPECIFIED:

DIMENSIONS ARE IN INCHES
 TOLERANCES:
 FRACTIONAL ±
 ANGULAR: MACH ± BEND ±
 TWO PLACE DECIMAL ±
 THREE PLACE DECIMAL ±

INTERPRET GEOMETRIC
 TOLERANCING PER:

MATERIAL

FINISH

DO NOT SCALE DRAWING

NAME

DATE

DRAWN

CHECKED

ENG APPR.

MFG APPR.

Q.A.

COMMENTS:

ACRYLIC

TITLE:

AQR10-L12-A180-2-L-NL-MN-41K

SIZE
A

DWG. NO.

REV

SCALE: 1:3

WEIGHT:

SHEET 8 OF 13

PROPRIETARY AND CONFIDENTIAL
 THE INFORMATION CONTAINED IN THIS
 DRAWING IS THE SOLE PROPERTY OF
 <INSERT COMPANY NAME HERE>. ANY
 REPRODUCTION IN PART OR AS A WHOLE
 WITHOUT THE WRITTEN PERMISSION OF
 <INSERT COMPANY NAME HERE> IS
 PROHIBITED.

NEXT ASSY

USED ON

APPLICATION

5

4

3

2

1

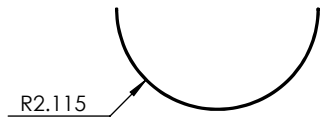
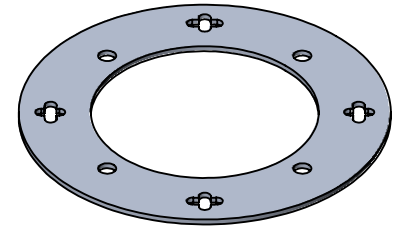
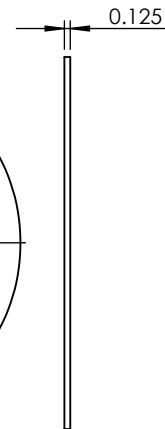
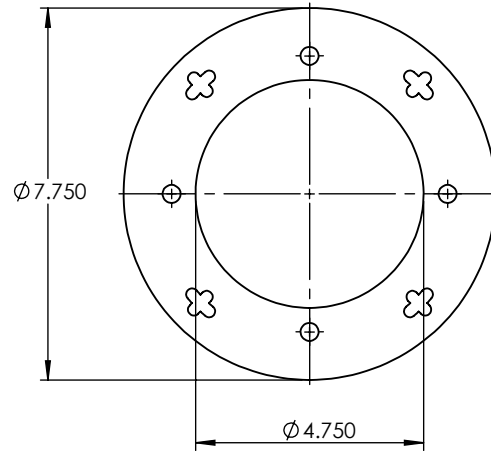
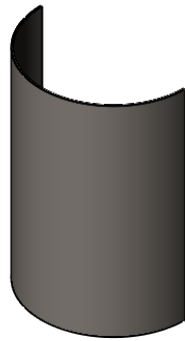
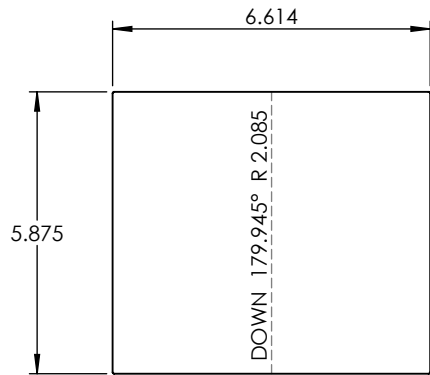
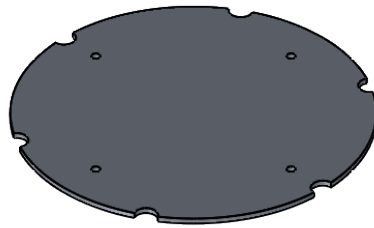
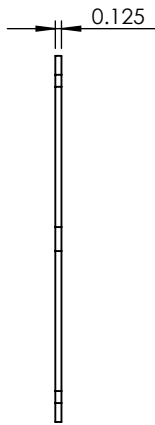
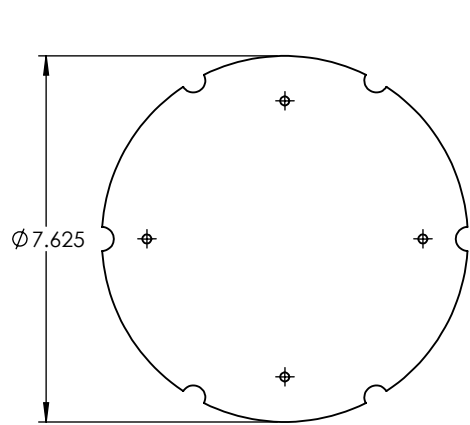

PROPRIETARY AND CONFIDENTIAL
 THE INFORMATION CONTAINED IN THIS DRAWING IS THE SOLE PROPERTY OF <INSERT COMPANY NAME HERE>. ANY REPRODUCTION IN PART OR AS A WHOLE WITHOUT THE WRITTEN PERMISSION OF <INSERT COMPANY NAME HERE> IS PROHIBITED.

		UNLESS OTHERWISE SPECIFIED:		NAME	DATE
		DIMENSIONS ARE IN INCHES	DRAWN		
		TOLERANCES:	CHECKED		
		FRACTIONAL ±	ENG APPR.		
		ANGULAR: MACH ± BEND ±	MFG APPR.		
		TWO PLACE DECIMAL ±	Q.A.		
		THREE PLACE DECIMAL ±	COMMENTS:		
		INTERPRET GEOMETRIC TOLERANCING PER:			
		MATERIAL			
NEXT ASSY	USED ON	FINISH			
APPLICATION		DO NOT SCALE DRAWING			

ALUMINUM 0.125" PLATE

TITLE:

AQR10-L12-A180-2-L-NL-MN-41K

SIZE	DWG. NO.	REV
A		

SCALE: 1:4	WEIGHT:	SHEET 9 OF 13
------------	---------	---------------

ITEM NO.	PART NUMBER	DESCRIPTION	QTY.
1	AQR10-L12-A180-2-L-NL-MN-41K-SPUN SPHERE	SPUN ALUMINUM 0.080"	1

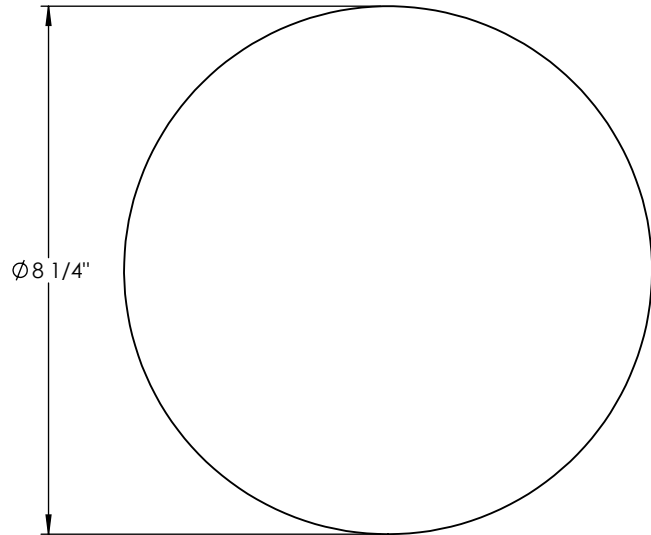
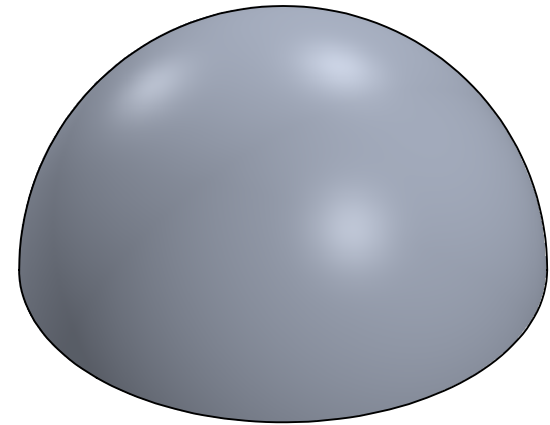
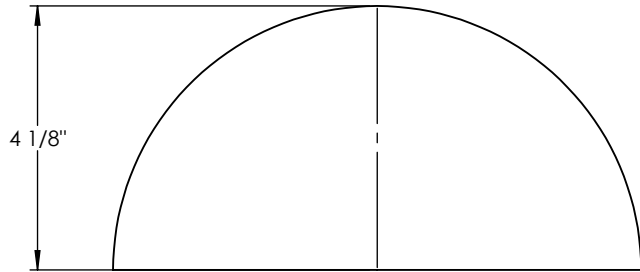

UNLESS OTHERWISE SPECIFIED: DIMENSIONS ARE IN INCHES TOLERANCES: FRACTIONAL ± ANGULAR: MACH ± BEND ± TWO PLACE DECIMAL ± THREE PLACE DECIMAL ±		NAME	DATE	SPUN ALUMINUM 0.080"		
	DRAWN					
	CHECKED			AQR10-L12-A180-2-L-NL-MN-41K		
	ENG APPR.					
	MFG APPR.			SIZE DWG. NO. REV		
Q.A.			SCALE: 1:3 WEIGHT: SHEET 10 OF 13			
INTERPRET GEOMETRIC TOLERANCING PER:	COMMENTS:					
MATERIAL						
FINISH						
APPLICATION						
DO NOT SCALE DRAWING						

PROPRIETARY AND CONFIDENTIAL
THE INFORMATION CONTAINED IN THIS DRAWING IS THE SOLE PROPERTY OF <INSERT COMPANY NAME HERE>. ANY REPRODUCTION IN PART OR AS A WHOLE WITHOUT THE WRITTEN PERMISSION OF <INSERT COMPANY NAME HERE> IS PROHIBITED.

NEXT ASSY	USED ON
APPLICATION	

5

4

3

2

1

ITEM NO.	PART NUMBER	DESCRIPTION	QTY.
1	AQR10-L12-A180-2-L-NL-MN-41K-4.5" LENS BRACKET	SPUN ALUMINUM 0.080"	2

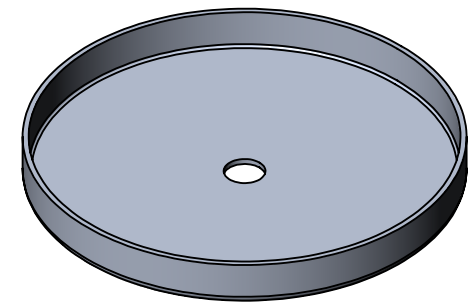
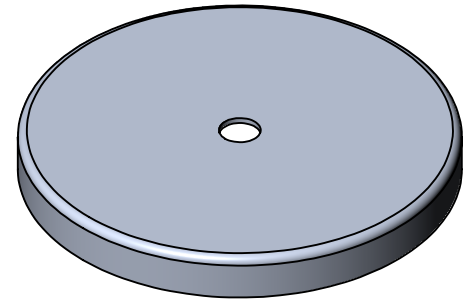
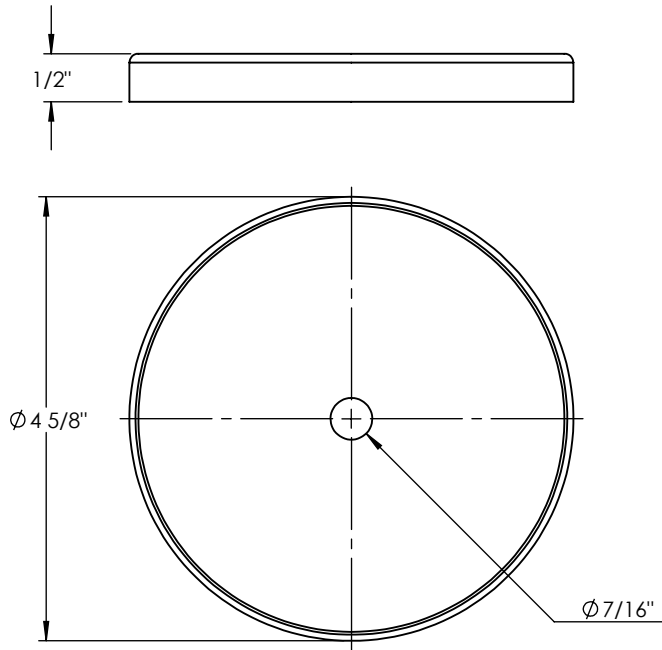

UNLESS OTHERWISE SPECIFIED:

DIMENSIONS ARE IN INCHES
 TOLERANCES:
 FRACTIONAL \pm
 ANGULAR: MACH \pm BEND \pm
 TWO PLACE DECIMAL \pm
 THREE PLACE DECIMAL \pm

INTERPRET GEOMETRIC
 TOLERANCING PER:

MATERIAL

FINISH

DO NOT SCALE DRAWING

NAME

DATE

DRAWN

CHECKED

ENG APPR.

MFG APPR.

Q.A.

COMMENTS:

SPUN ALUMINUM 0.080"

TITLE:

AQR10-L12-A180-2-L-NL-MN-41K

SIZE
A

DWG. NO.

REV

SCALE: 1:2

WEIGHT:

SHEET 11 OF 13

PROPRIETARY AND CONFIDENTIAL

THE INFORMATION CONTAINED IN THIS DRAWING IS THE SOLE PROPERTY OF <INSERT COMPANY NAME HERE>. ANY REPRODUCTION IN PART OR AS A WHOLE WITHOUT THE WRITTEN PERMISSION OF <INSERT COMPANY NAME HERE> IS PROHIBITED.

NEXT ASSY	USED ON
APPLICATION	

ITEM NO.	PART NUMBER	DESCRIPTION	QTY.
1	AQR10-L12-A180-2-L-NL-MN-41K-SPUN COVER	SPUN ALUMINUM 0.080"	1

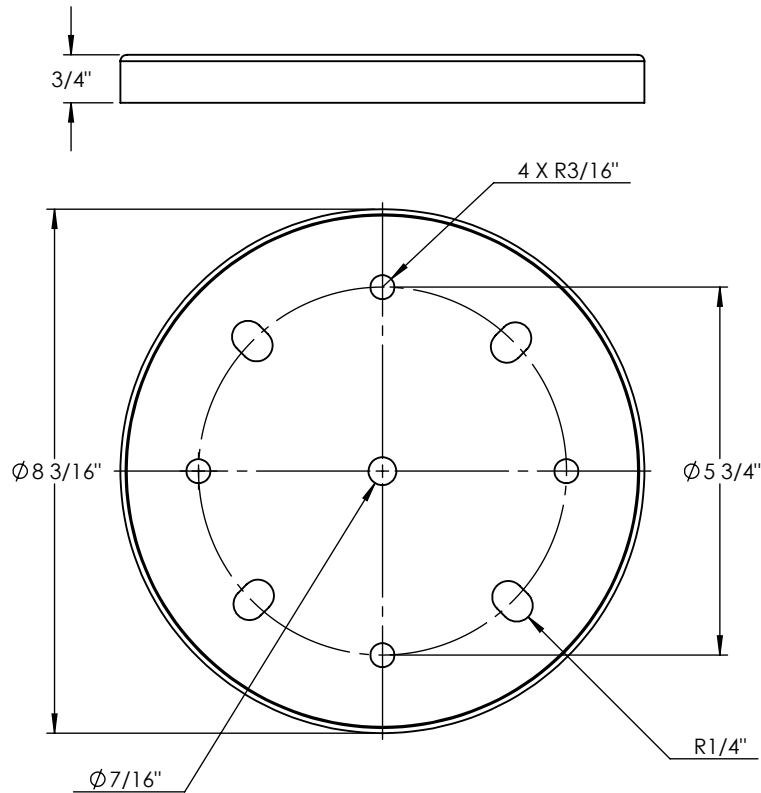
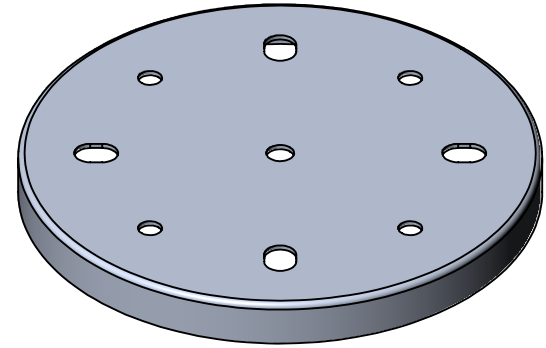

UNLESS OTHERWISE SPECIFIED:

DIMENSIONS ARE IN INCHES
 TOLERANCES:
 FRACTIONAL ±
 ANGULAR: MACH ± BEND ±
 TWO PLACE DECIMAL ±
 THREE PLACE DECIMAL ±

INTERPRET GEOMETRIC
 TOLERANCING PER:

MATERIAL

FINISH

DO NOT SCALE DRAWING

NAME

DATE

SPUN ALUMINUM 0.080"

TITLE:

AQR10-L12-A180-2-L-NL-MN-41K

SIZE
A

DWG. NO.

REV

SCALE: 1:3

WEIGHT:

SHEET 12 OF 13

PROPRIETARY AND CONFIDENTIAL

THE INFORMATION CONTAINED IN THIS DRAWING IS THE SOLE PROPERTY OF <INSERT COMPANY NAME HERE>. ANY REPRODUCTION IN PART OR AS A WHOLE WITHOUT THE WRITTEN PERMISSION OF <INSERT COMPANY NAME HERE> IS PROHIBITED.

NEXT ASSY	USED ON
APPLICATION	

DRAWN		
CHECKED		
ENG APPR.		
MFG APPR.		
Q.A.		
COMMENTS:		

ITEM NO.	PART NUMBER	DESCRIPTION	QTY.
1	AQR10-L12-A180-2-L-NL-MN-41K-HORIZONTAL LOUVER	SPUN ALUMINUM 0.0635"	1

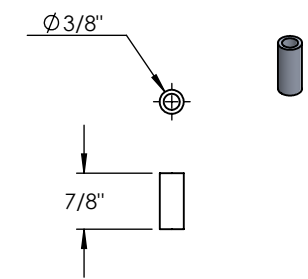
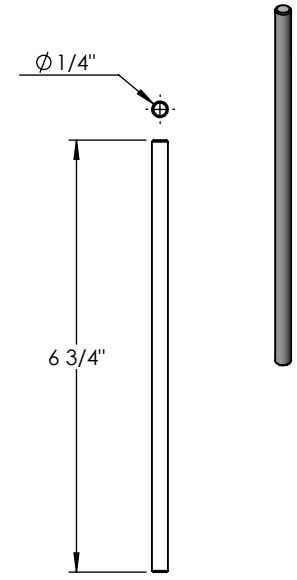
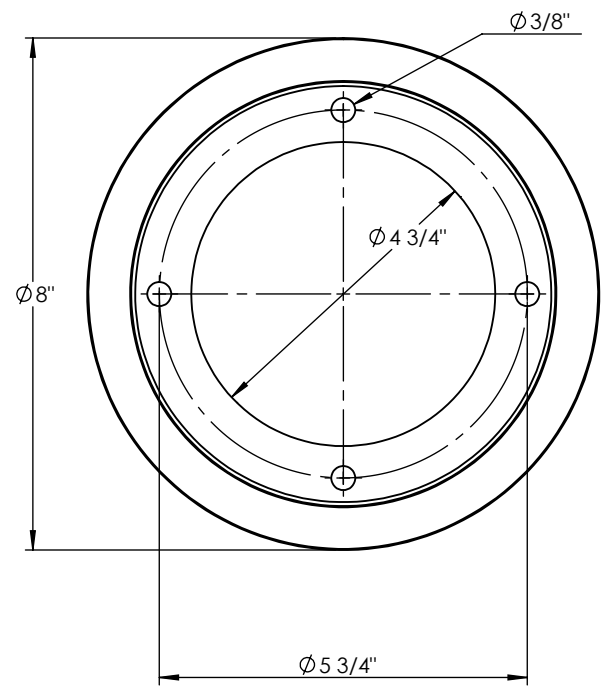
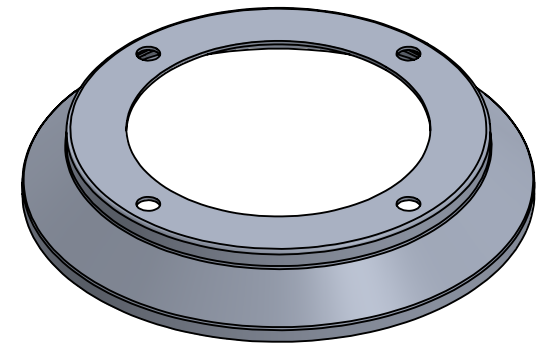
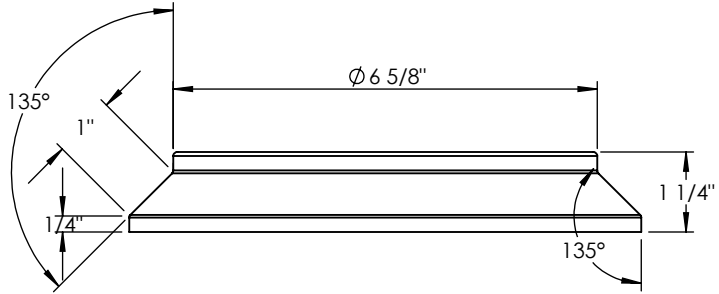

UNLESS OTHERWISE SPECIFIED:		NAME	DATE	SPUN ALUMINUM 0.0635"	
DIMENSIONS ARE IN INCHES		DRAWN		TITLE:	
TOLERANCES:		CHECKED		AQR10-L12-A180-2-L-NL-MN-41K	
FRACTIONAL ±		ENG APPR.		SIZE	DWG. NO.
ANGULAR: MACH ± BEND ±		MFG APPR.		A	
TWO PLACE DECIMAL ±		Q.A.		SCALE: 1:3	WEIGHT:
THREE PLACE DECIMAL ±		COMMENTS:			SHEET 13 OF 13
INTERPRET GEOMETRIC TOLERANCING PER:				REV	
MATERIAL					
FINISH					
NEXT ASSY	USED ON				
APPLICATION		DO NOT SCALE DRAWING			

PROPRIETARY AND CONFIDENTIAL
 THE INFORMATION CONTAINED IN THIS DRAWING IS THE SOLE PROPERTY OF <INSERT COMPANY NAME HERE>. ANY REPRODUCTION IN PART OR AS A WHOLE WITHOUT THE WRITTEN PERMISSION OF <INSERT COMPANY NAME HERE> IS PROHIBITED.