

ALL BEND RADIUS .030"

UNLESS OTHERWISE SPECIFIED:	NAME	DATE
DIMENSIONS ARE IN INCHES	DRAWN	
TOLERANCES:	CHECKED	
FRACTIONAL ± .003	ENG APPR.	
ANGULAR: MACH ± .01 BEND ±	MFG APPR.	
TWO PLACE DECIMAL ±	Q.A.	
THREE PLACE DECIMAL ±.001	COMMENTS:	
INTERPRET GEOMETRIC TOLERANCING PER:		
MATERIAL		
FINISH		
APPLICATION		
DO NOT SCALE DRAWING		

TITLE:
PST-DN-120LS-TBR-CFG-33X28-27K

SIZE	DWG. NO.	REV
A	TICKET 25165	

SCALE: 1:18	WEIGHT:	SHEET 1 OF 12
-------------	---------	---------------

ITEM NO.	PART NUMBER	DESCRIPTION	QTY.	CUT
1	PST-DN-120LS-TBR-CFG-33X28-27K-POST FITTER	3" ALUMINUM POST FITTER	1	
2	PST-DN-120LS-TBR-CFG-33X28-27K-SPUN SHADE	SPUN ALUMINUM 0.080"	1	
3	PST-DN-120LS-TBR-CFG-33X28-27K-SPUN SHADE FITTER	SPUN ALUMINUM 0.080"	1	
4	PST-DN-120LS-TBR-CFG-33X28-27K-SPUN SEAT	SPUN ALUMINUM 0.080"	1	
5	PST-DN-120LS-TBR-CFG-33X28-27K-SPUN DOOR	SPUN ALUMINUM 0.080"	1	
6	PST-DN-120LS-TBR-CFG-33X28-27K-BOTTOM SUPPORT PLATE	ALUMINUM 0.250" PLATE	1	
7	PST-DN-120LS-TBR-CFG-33X28-27K-CENTER WIRE PLATE	ALUMINUM 0.250" PLATE	1	
8	PST-DN-120LS-TBR-CFG-33X28-27K-TOP SUPPORT PLATE	ALUMINUM 0.250" PLATE	1	
9	PST-DN-120LS-TBR-CFG-33X28-27K-TOP SUPPORT PLATE RING	ALUMINUM 0.250" PLATE	4	
10	PST-DN-120LS-TBR-CFG-33X28-27K-LED BRACKET	ALUMINUM 0.0635"	2	
11	PST-DN-120LS-TBR-CFG-33X28-27K-LED PLATE	ALUMINUM 0.0635"	1	
12	PST-DN-120LS-TBR-CFG-33X28-27K-DRIVER BRACKET	ALUMINUM 0.0635"	1	
13	PST-DN-120LS-TBR-CFG-33X28-27K-DRIVER BRACKET 2	ALUMINUM 0.0635"	1	
14	PST-DN-120LS-TBR-CFG-33X28-27K-DRIVER BRACKET 3	ALUMINUM 0.0635"	1	
15	PST-DN-120LS-TBR-CFG-33X28-27K-0.750" ROUND TUBE	3/4" ROUND ALUMINUM TUBE	1	
16	PST-DN-120LS-TBR-CFG-33X28-27K-0.750" SOLID BAR	3/4" ROUND ALUMINUM BAR	1	
17	PST-DN-120LS-TBR-CFG-33X28-27K-0.750" SOLID BAR SHORT ACCENT	3/4" ROUND ALUMINUM BAR	1	
18	PST-DN-120LS-TBR-CFG-33X28-27K-ACRYLIC	ACRYLIC	1	
19	46 MM HEAT SINK	HEAT SINK	14	
20	ESPEN VEL29070MVH-1	DRIVER	7	
21	AltaiLED_PCN_D1500_110B-10 WATT	LED	14	

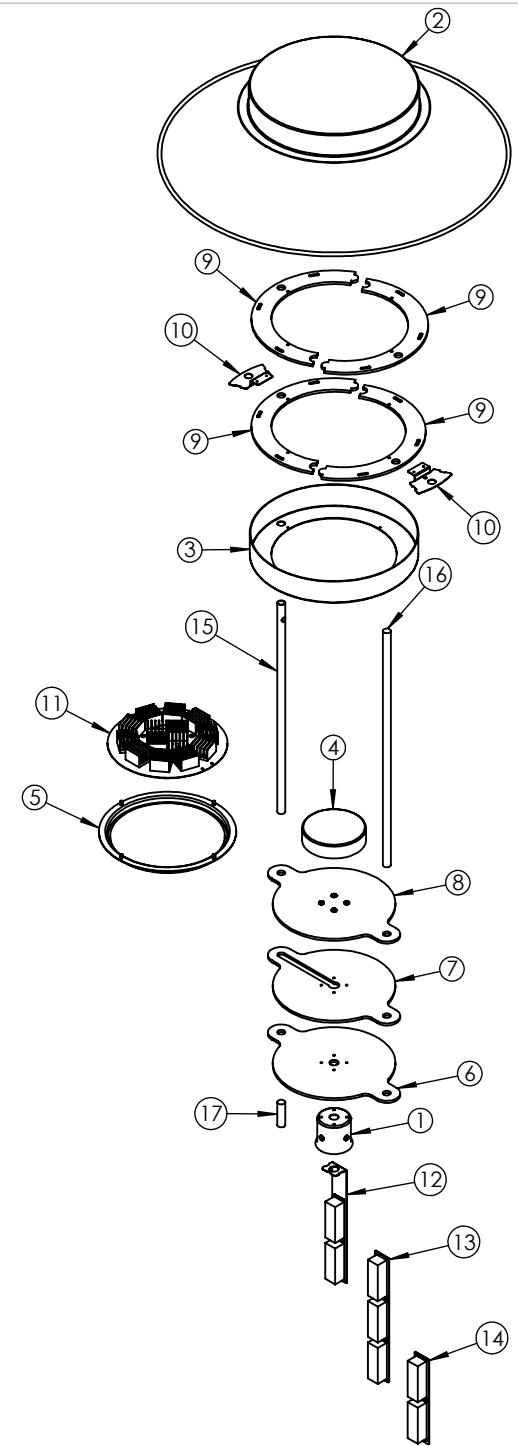

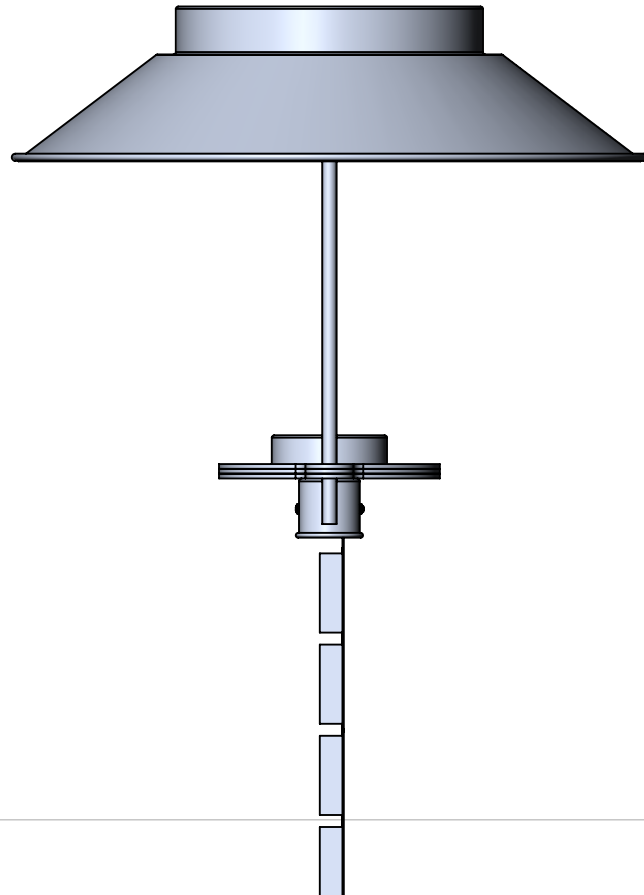
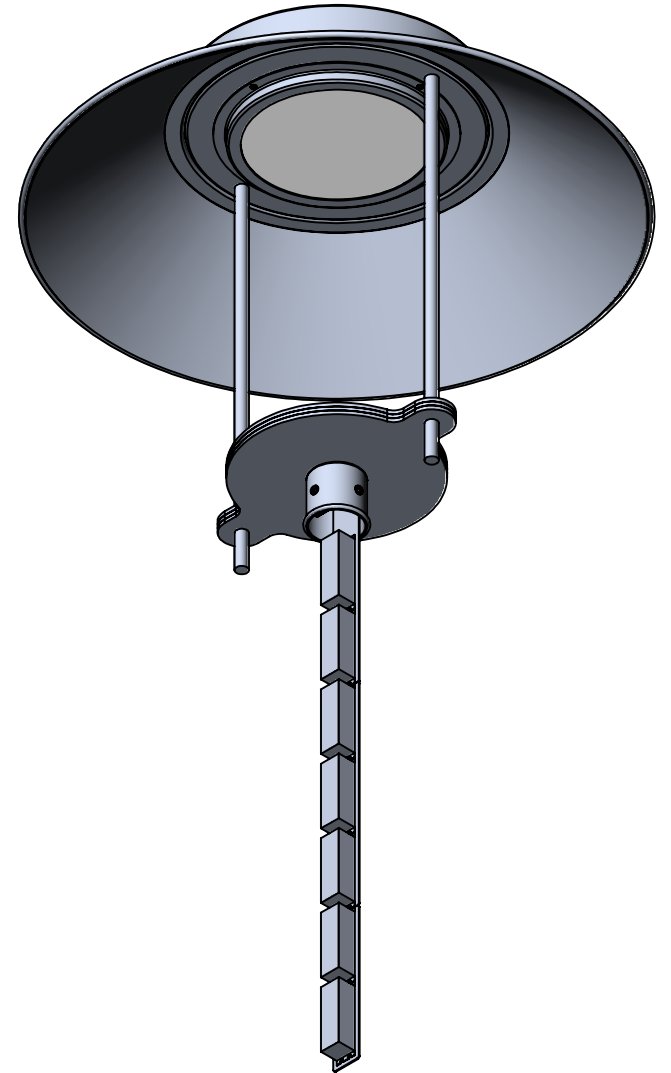
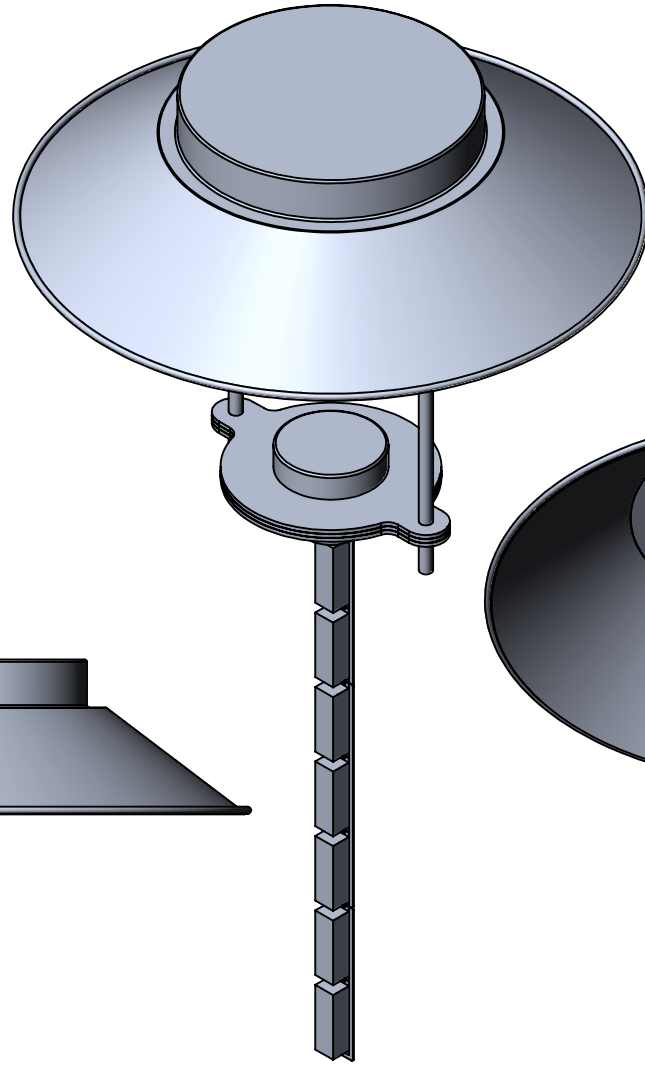
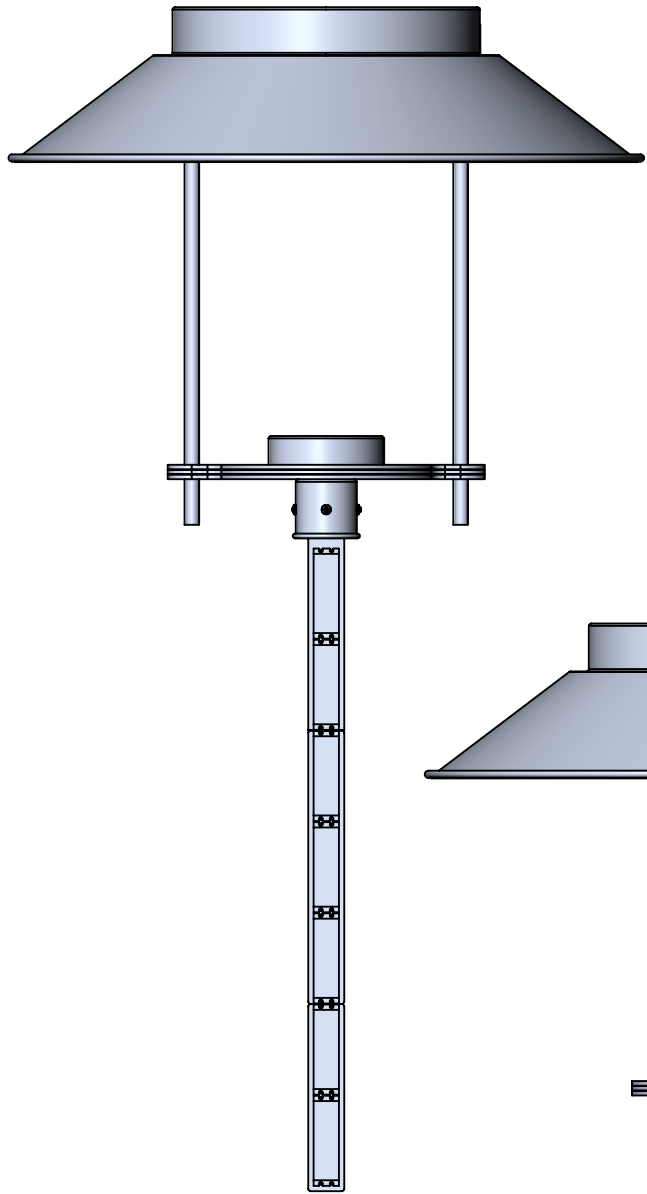

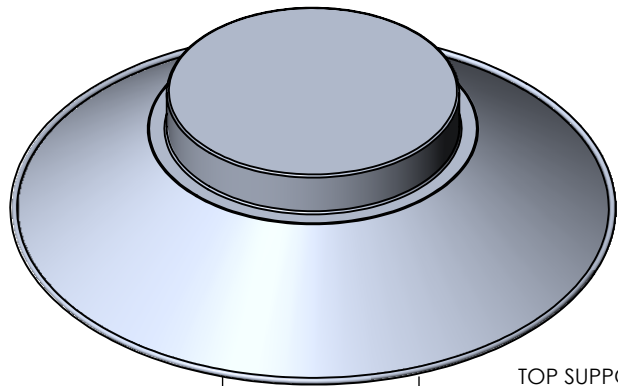

TOP SUPPORT PLATE

BRACKETS WELDED
TO BOTTOM
SUPPORT PLATE

BOTTOM SUPPORT PLATE

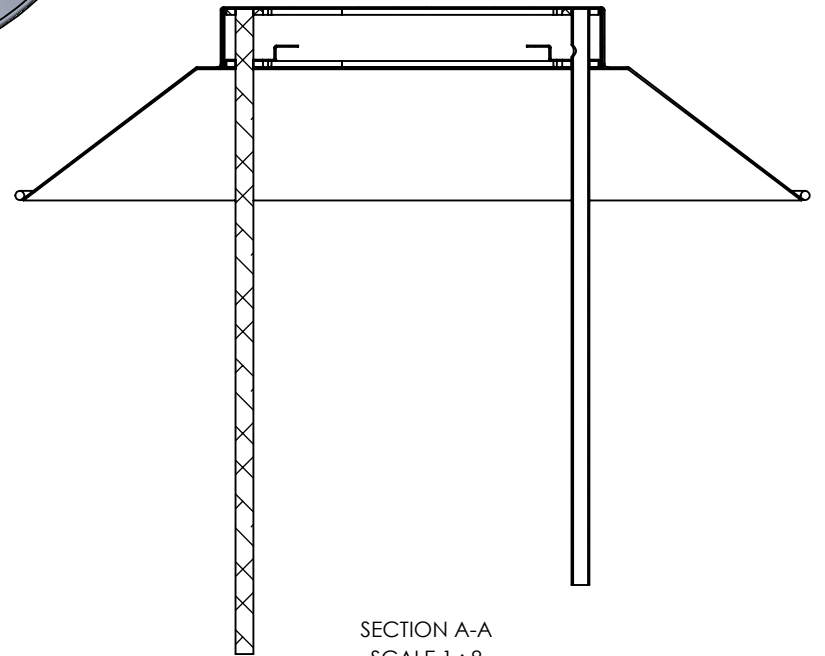
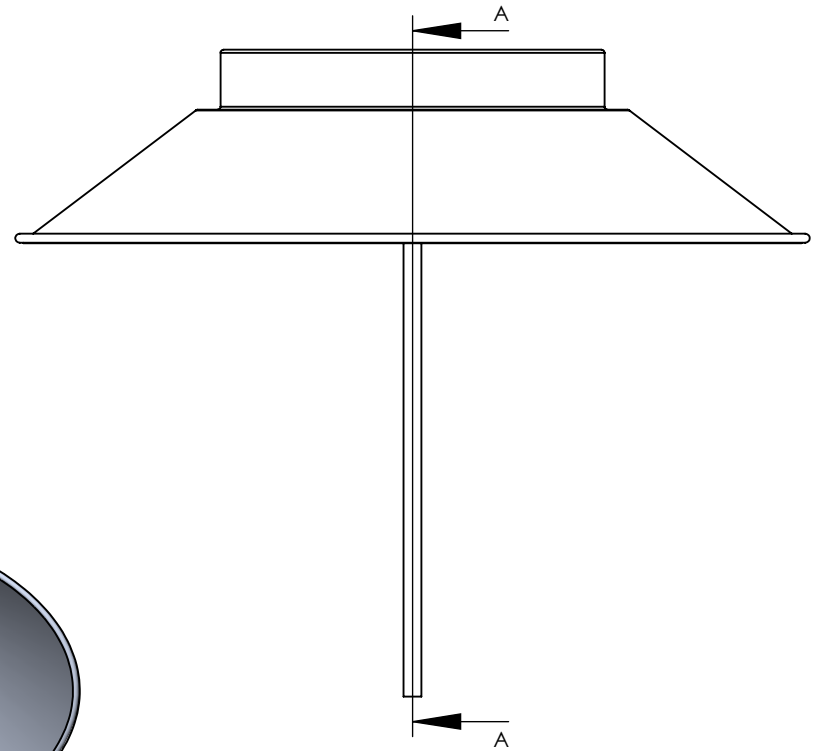
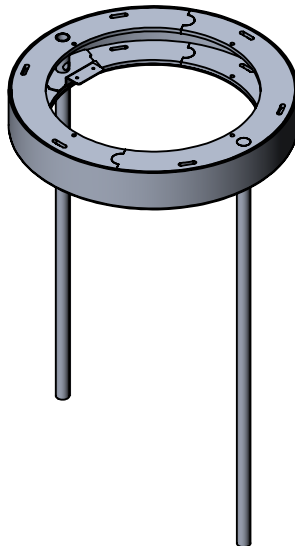
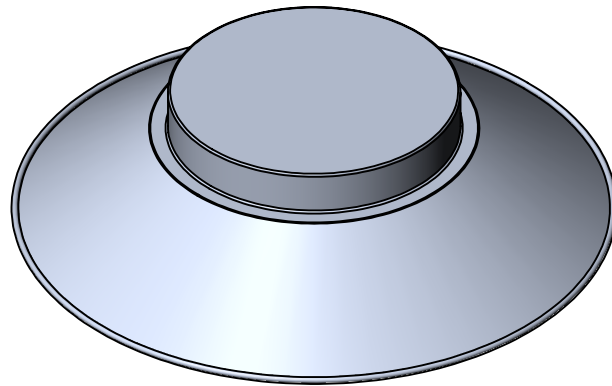
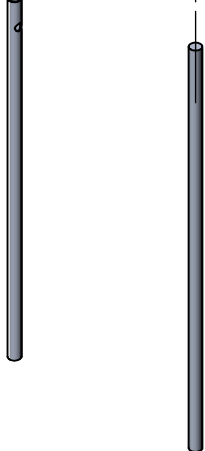
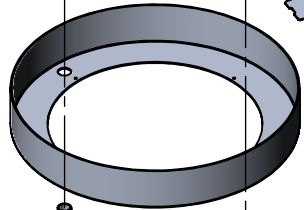
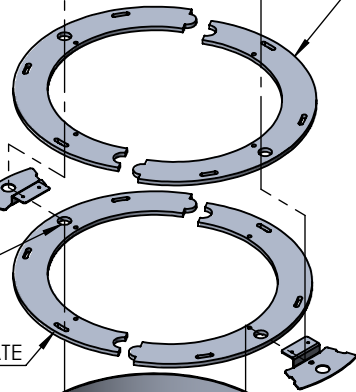

SECTION A-A
SCALE 1 : 8

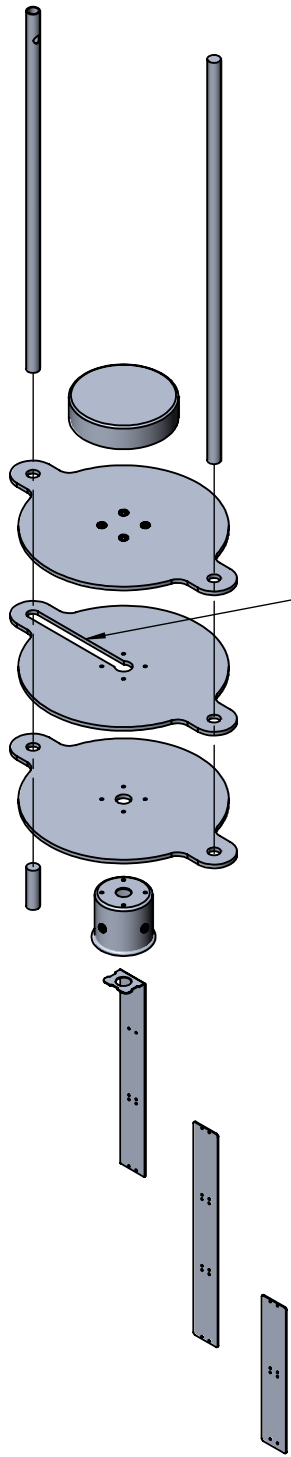

WIRE CHANNEL

SPUN CAP AS ACCENT ONLY

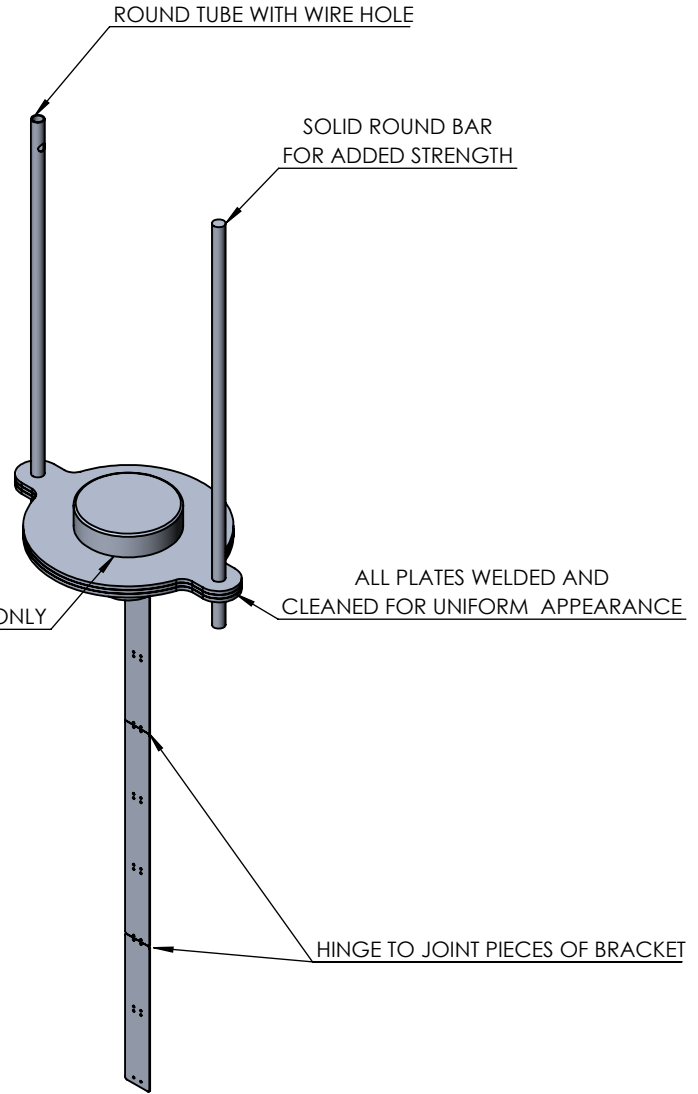

ROUND TUBE WITH WIRE HOLE

SOLID ROUND BAR FOR ADDED STRENGTH

ALL PLATES WELDED AND CLEANED FOR UNIFORM APPEARANCE

HINGE TO JOINT PIECES OF BRACKET

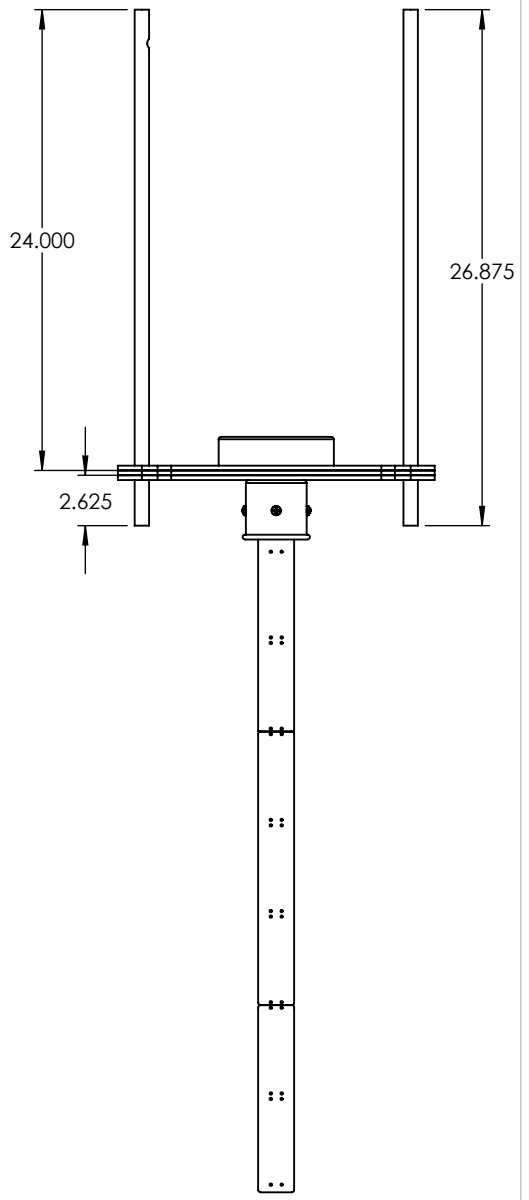

24.000

26.875

2.625

ITEM NO.	PART NUMBER	DESCRIPTION	QTY.
1	PST-DN-120LS-TBR-CFG-33X28-27K-SPUN SHADE	SPUN ALUMINUM 0.080"	1

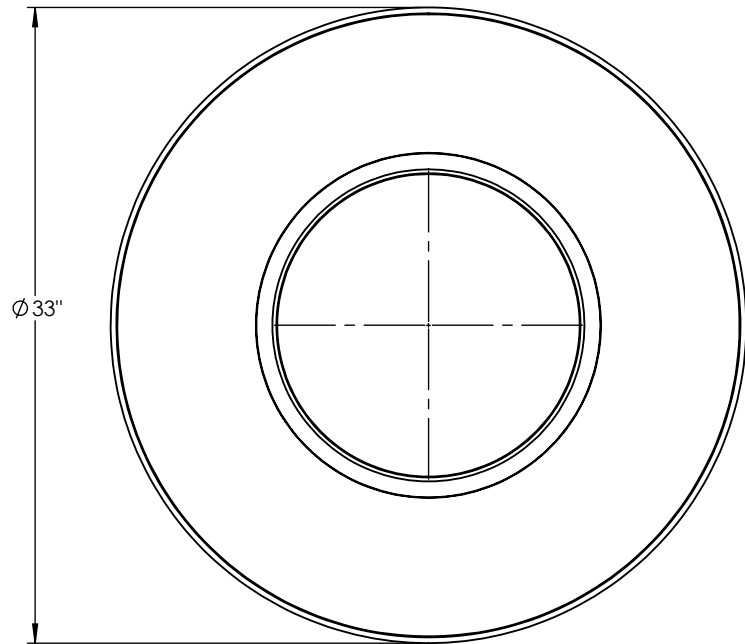
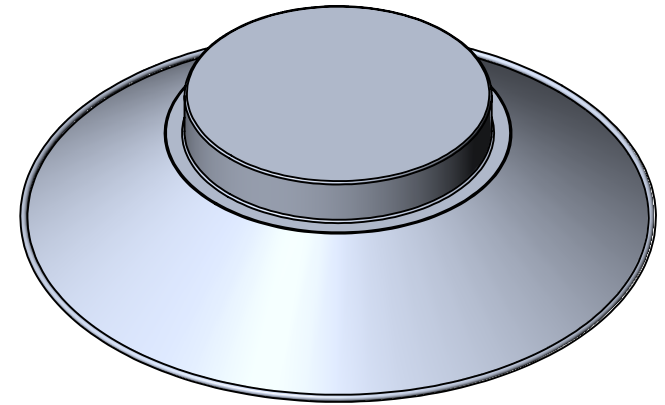
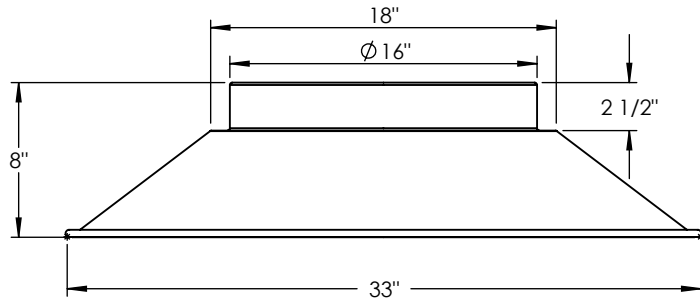

PROPRIETARY AND CONFIDENTIAL
 THE INFORMATION CONTAINED IN THIS DRAWING IS THE SOLE PROPERTY OF <INSERT COMPANY NAME HERE>. ANY REPRODUCTION IN PART OR AS A WHOLE WITHOUT THE WRITTEN PERMISSION OF <INSERT COMPANY NAME HERE> IS PROHIBITED.

		UNLESS OTHERWISE SPECIFIED:	NAME	DATE
		DIMENSIONS ARE IN INCHES TOLERANCES: FRACTIONAL ± ANGULAR: MACH ± BEND ± TWO PLACE DECIMAL ± THREE PLACE DECIMAL ±	DRAWN	
		INTERPRET GEOMETRIC TOLERANCING PER:	CHECKED	
		MATERIAL	ENG APPR.	
		FINISH	MFG APPR.	
NEXT ASSY	USED ON		Q.A.	
APPLICATION		DO NOT SCALE DRAWING	COMMENTS:	

SPUN ALUMINUM 0.080"		
TITLE:		
PST-DN-120LS-TBR-CFG-33X28-27K		
SIZE	DWG. NO.	REV
A		
SCALE: 1:10	WEIGHT:	SHEET 6 OF 12

ITEM NO.	PART NUMBER	DESCRIPTION	QTY.
1	PST-DN-120LS-TBR-CFG-33X28-27K-SPUN SHADE FITTER	SPUN ALUMINUM 0.080"	1

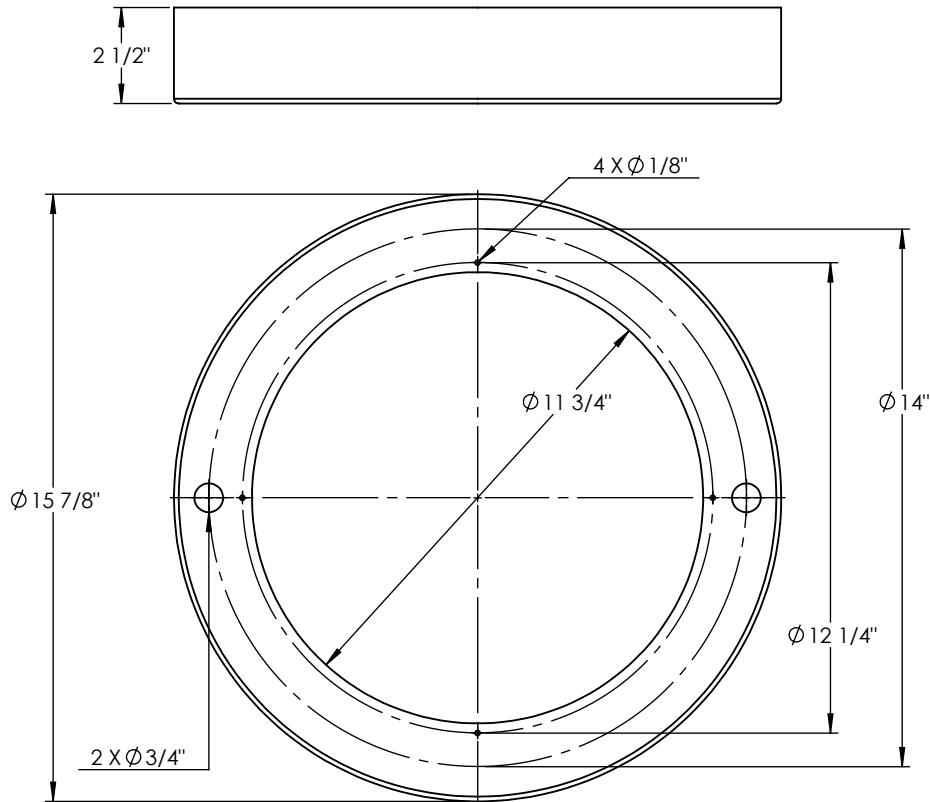
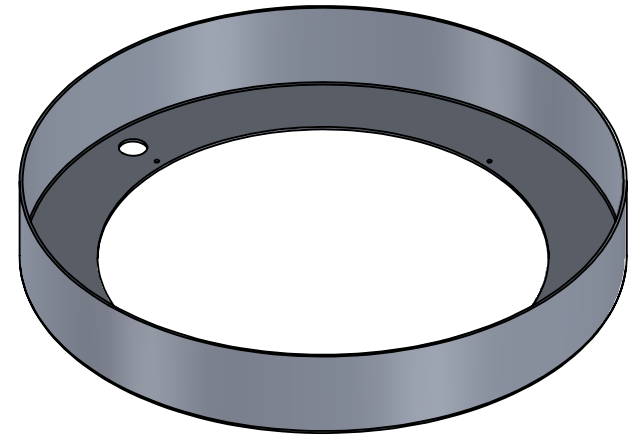

PROPRIETARY AND CONFIDENTIAL
 THE INFORMATION CONTAINED IN THIS DRAWING IS THE SOLE PROPERTY OF <INSERT COMPANY NAME HERE>. ANY REPRODUCTION IN PART OR AS A WHOLE WITHOUT THE WRITTEN PERMISSION OF <INSERT COMPANY NAME HERE> IS PROHIBITED.

		UNLESS OTHERWISE SPECIFIED:	NAME	DATE
		DIMENSIONS ARE IN INCHES TOLERANCES: FRACTIONAL ± ANGULAR: MACH ± BEND ± TWO PLACE DECIMAL ± THREE PLACE DECIMAL ±	DRAWN	
		INTERPRET GEOMETRIC TOLERANCING PER:	CHECKED	
		MATERIAL	ENG APPR.	
		FINISH	MFG APPR.	
NEXT ASSY	USED ON		Q.A.	
APPLICATION		DO NOT SCALE DRAWING	COMMENTS:	

SPUN ALUMINUM 0.080"		
TITLE:		
PST-DN-120LS-TBR-CFG-33X28-27K		
SIZE	DWG. NO.	REV
A		
SCALE: 1:5	WEIGHT:	SHEET 7 OF 12

ITEM NO.	PART NUMBER	DESCRIPTION	QTY.
1	PST-DN-120LS-TBR-CFG-33X28-27K-SPUN SEAT	SPUN ALUMINUM 0.080"	1

ITEM NO.	PART NUMBER	DESCRIPTION	QTY.
1	PST-DN-120LS-TBR-CFG-33X28-27K-POST FITTER	3" ALUMINUM POST FITTER	1

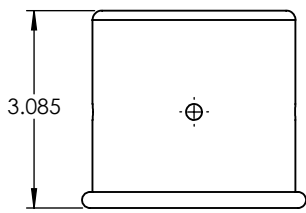
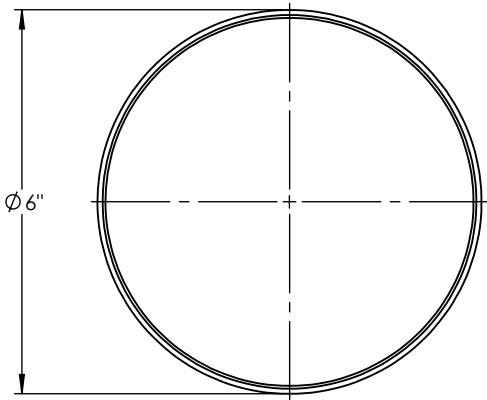
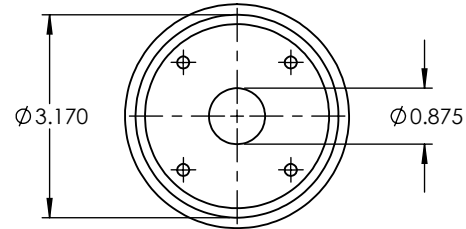
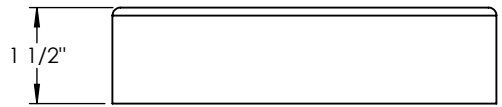
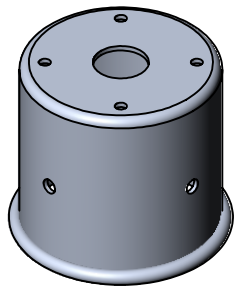
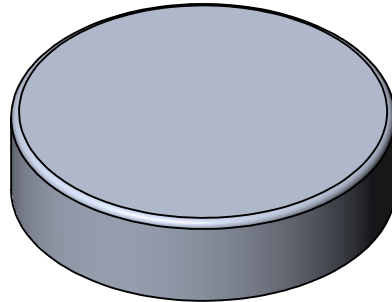

UNLESS OTHERWISE SPECIFIED:		NAME	DATE	3" ALUMINUM POST FITTER	
DIMENSIONS ARE IN INCHES TOLERANCES: FRACTIONAL ± ANGULAR: MACH ± BEND ± TWO PLACE DECIMAL ± THREE PLACE DECIMAL ±		DRAWN			
INTERPRET GEOMETRIC TOLERANCING PER:		CHECKED		PST-DN-120LS-TBR-CFG-33X28-27K	
		ENG APPR.		SIZE DWG. NO. REV	
MATERIAL		MFG APPR.		SCALE: 1:3 WEIGHT: SHEET 8 OF 12	
FINISH		Q.A.			
APPLICATION		COMMENTS:			
DO NOT SCALE DRAWING					

PROPRIETARY AND CONFIDENTIAL
THE INFORMATION CONTAINED IN THIS DRAWING IS THE SOLE PROPERTY OF <INSERT COMPANY NAME HERE>. ANY REPRODUCTION IN PART OR AS A WHOLE WITHOUT THE WRITTEN PERMISSION OF <INSERT COMPANY NAME HERE> IS PROHIBITED.

ITEM NO.	PART NUMBER	DESCRIPTION	QTY.
1	PST-DN-120LS-TBR-CFG-33X28-27K-SPUN DOOR	SPUN ALUMINUM 0.080"	1

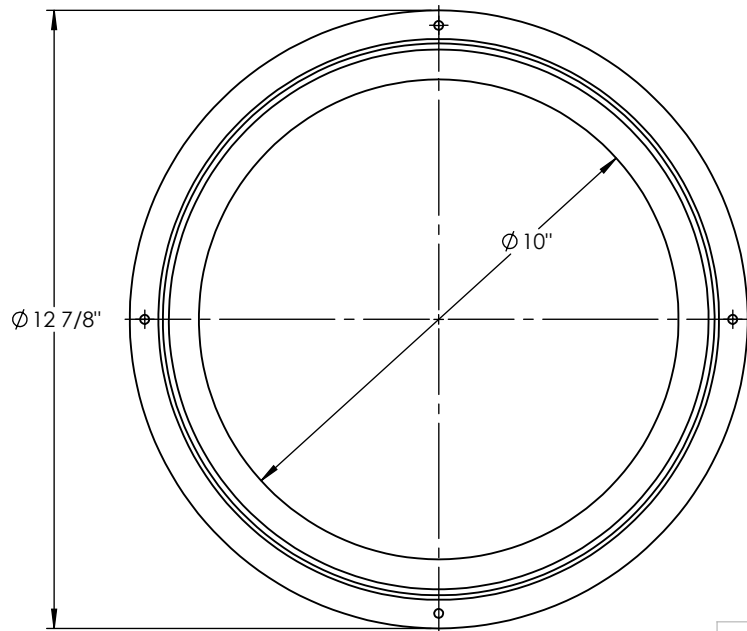
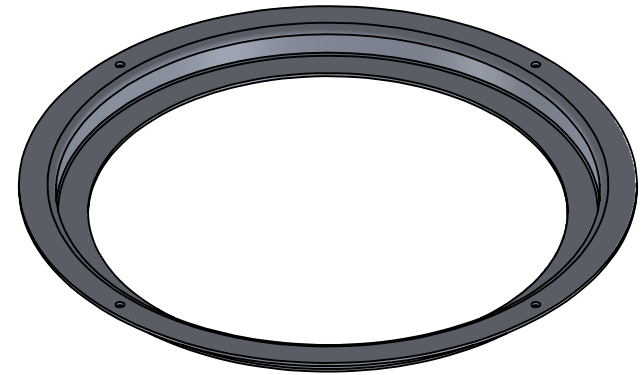
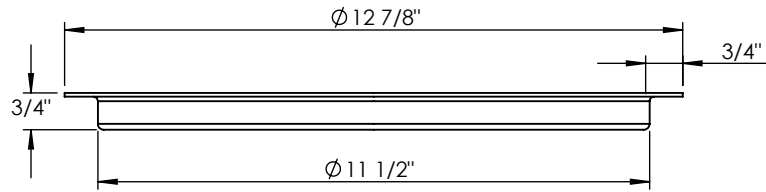

UNLESS OTHERWISE SPECIFIED:		NAME	DATE	SPUN ALUMINUM 0.080"	
DIMENSIONS ARE IN INCHES TOLERANCES: FRACTIONAL ± ANGULAR: MACH ± BEND ± TWO PLACE DECIMAL ± THREE PLACE DECIMAL ±		DRAWN			
INTERPRET GEOMETRIC TOLERANCING PER: MATERIAL FINISH		CHECKED		PST-DN-120LS-TBR-CFG-33X28-27K	
		ENG APPR.		SIZE DWG. NO. REV	
		MFG APPR.		SCALE: 1:4 WEIGHT: SHEET 9 OF 12	
NEXT ASSY		USED ON	COMMENTS:		
APPLICATION		DO NOT SCALE DRAWING			

PROPRIETARY AND CONFIDENTIAL
THE INFORMATION CONTAINED IN THIS DRAWING IS THE SOLE PROPERTY OF <INSERT COMPANY NAME HERE>. ANY REPRODUCTION IN PART OR AS A WHOLE WITHOUT THE WRITTEN PERMISSION OF <INSERT COMPANY NAME HERE> IS PROHIBITED.

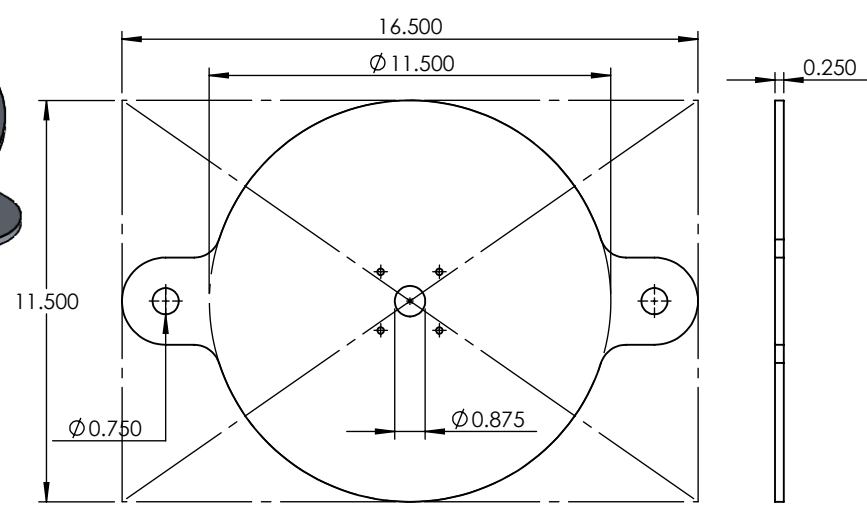
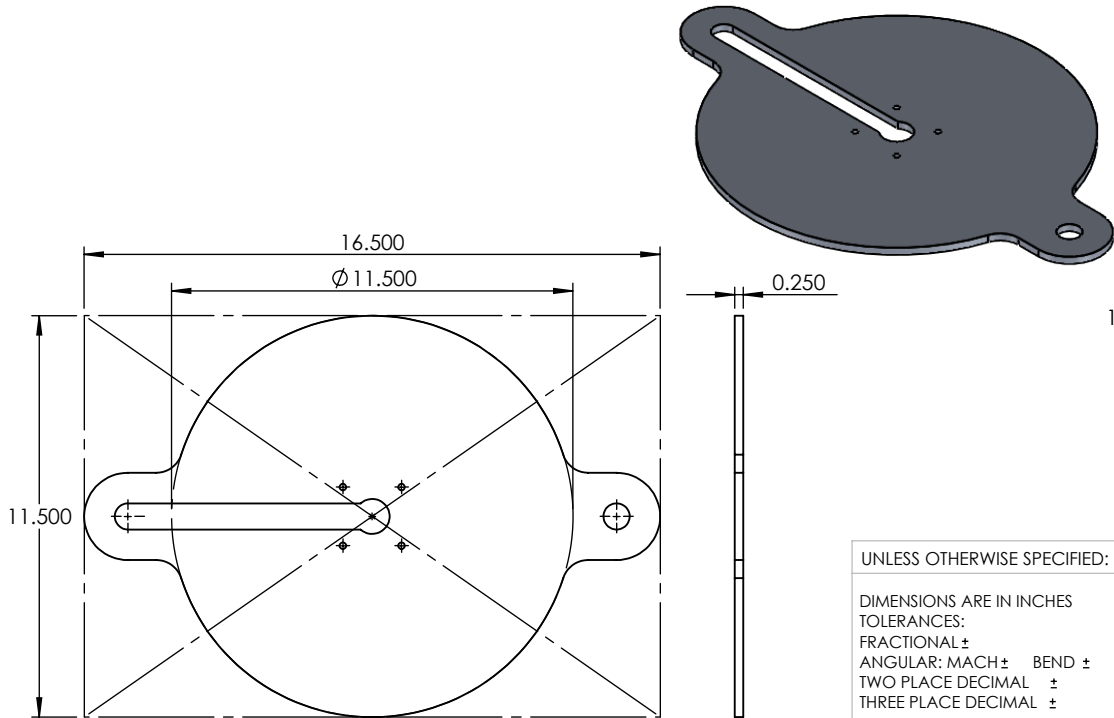
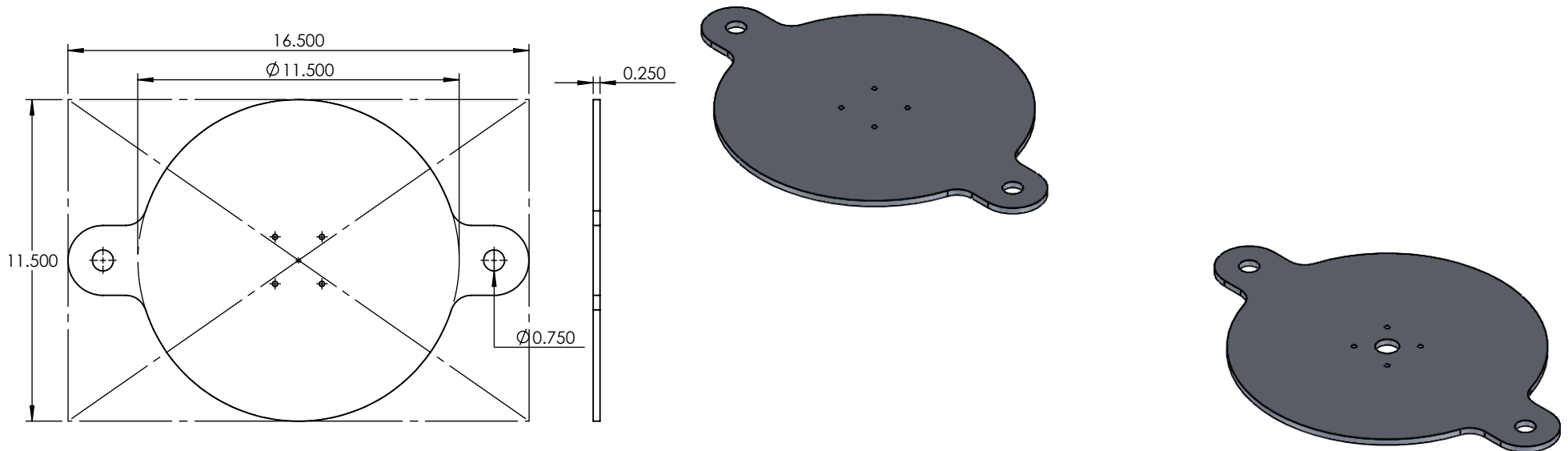

UNLESS OTHERWISE SPECIFIED:		NAME	DATE	ALUMINUM 0.250" PLATE
DIMENSIONS ARE IN INCHES TOLERANCES: FRACTIONAL ± ANGULAR: MACH ± BEND ± TWO PLACE DECIMAL ± THREE PLACE DECIMAL ±		DRAWN		
INTERPRET GEOMETRIC TOLERANCING PER:		CHECKED		PST-DN-120LS-TBR-CFG-33X28-27K
MATERIAL		ENG APPR.		
FINISH		MFG APPR.		REV
NEXT ASSY		Q.A.		SCALE: 1:5.5WEIGHT:
USED ON		COMMENTS:		
APPLICATION		DO NOT SCALE DRAWING		

PROPRIETARY AND CONFIDENTIAL
THE INFORMATION CONTAINED IN THIS DRAWING IS THE SOLE PROPERTY OF <INSERT COMPANY NAME HERE>. ANY REPRODUCTION IN PART OR AS A WHOLE WITHOUT THE WRITTEN PERMISSION OF <INSERT COMPANY NAME HERE> IS PROHIBITED.

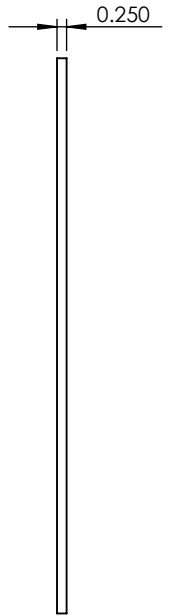
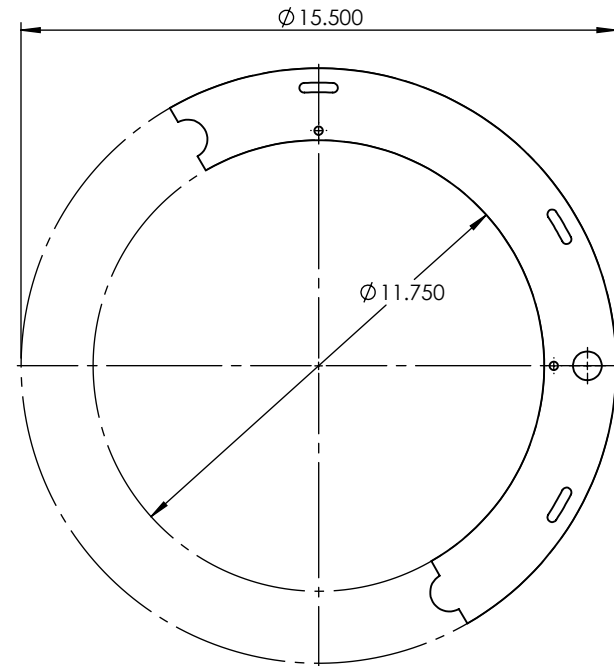
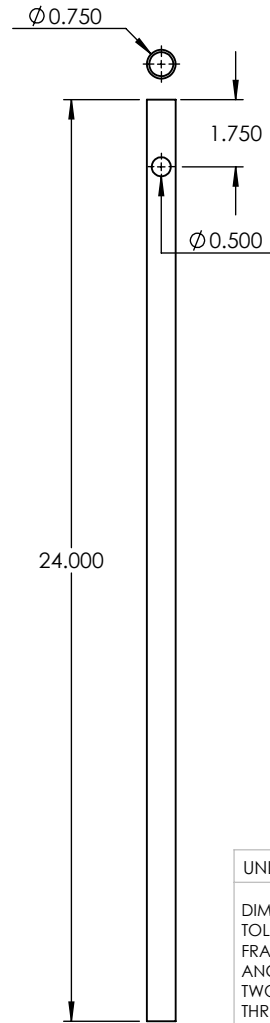
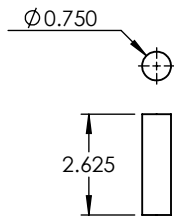
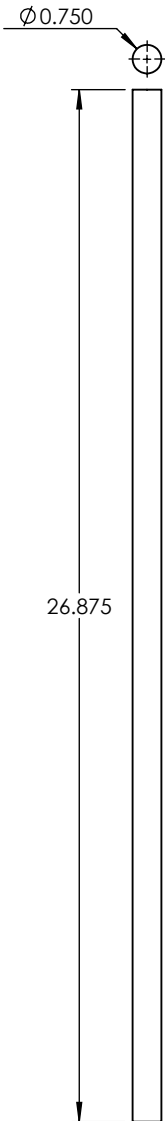
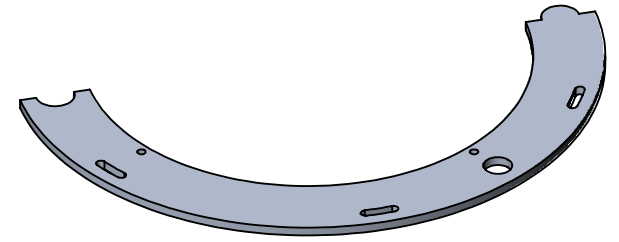
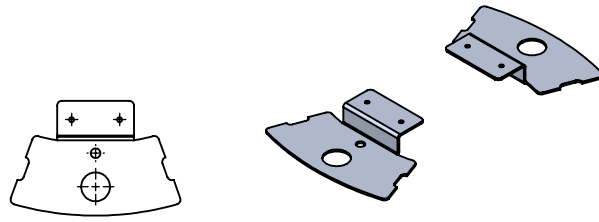
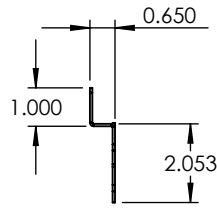
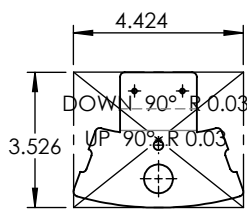

UNLESS OTHERWISE SPECIFIED:		NAME	DATE	ALUMINUM 0.0635"		
DIMENSIONS ARE IN INCHES		DRAWN				TITLE:
TOLERANCES:		CHECKED		PST-DN-120LS-TBR-CFG-33X28-27K		
FRACTIONAL ±		ENG APPR.				
ANGULAR: MACH ± BEND ±		MFG APPR.		SIZE	DWG. NO.	REV
TWO PLACE DECIMAL ±		Q.A.		A		
THREE PLACE DECIMAL ±		COMMENTS:			SCALE: 1:5	WEIGHT:
INTERPRET GEOMETRIC TOLERANCING PER:						
MATERIAL						
FINISH						
NEXT ASSY	USED ON					
APPLICATION		DO NOT SCALE DRAWING				

PROPRIETARY AND CONFIDENTIAL
 THE INFORMATION CONTAINED IN THIS DRAWING IS THE SOLE PROPERTY OF <INSERT COMPANY NAME HERE>. ANY REPRODUCTION IN PART OR AS A WHOLE WITHOUT THE WRITTEN PERMISSION OF <INSERT COMPANY NAME HERE> IS PROHIBITED.

5

4

3

2

1

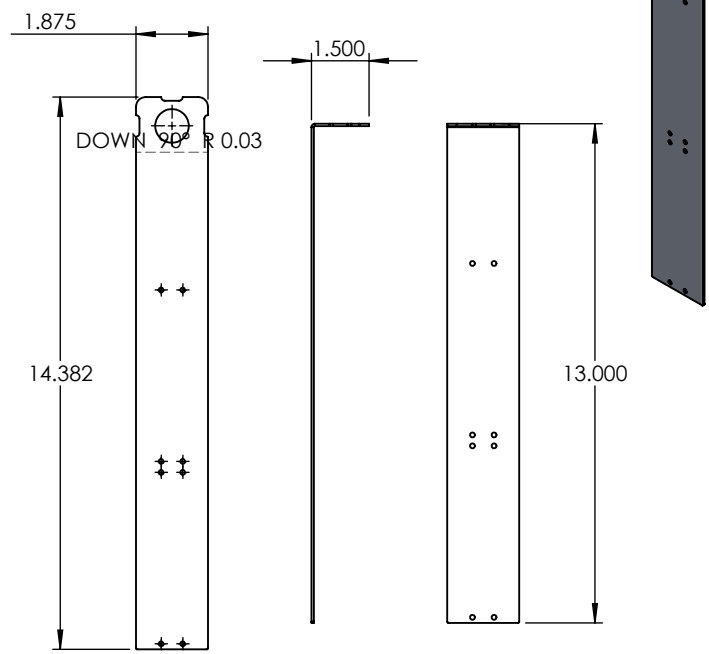
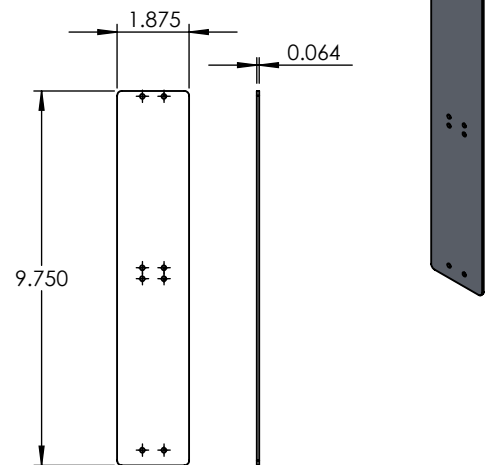
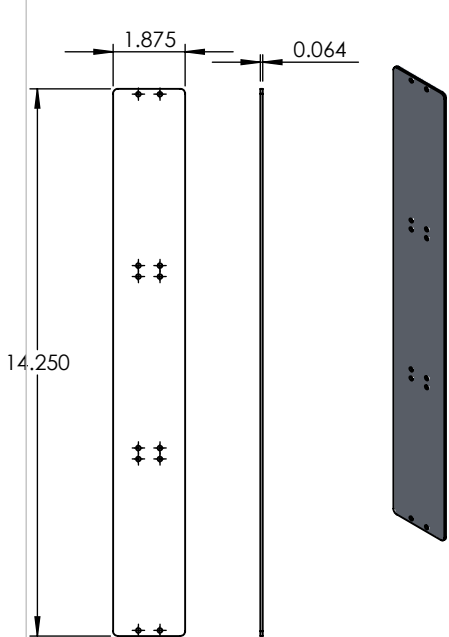
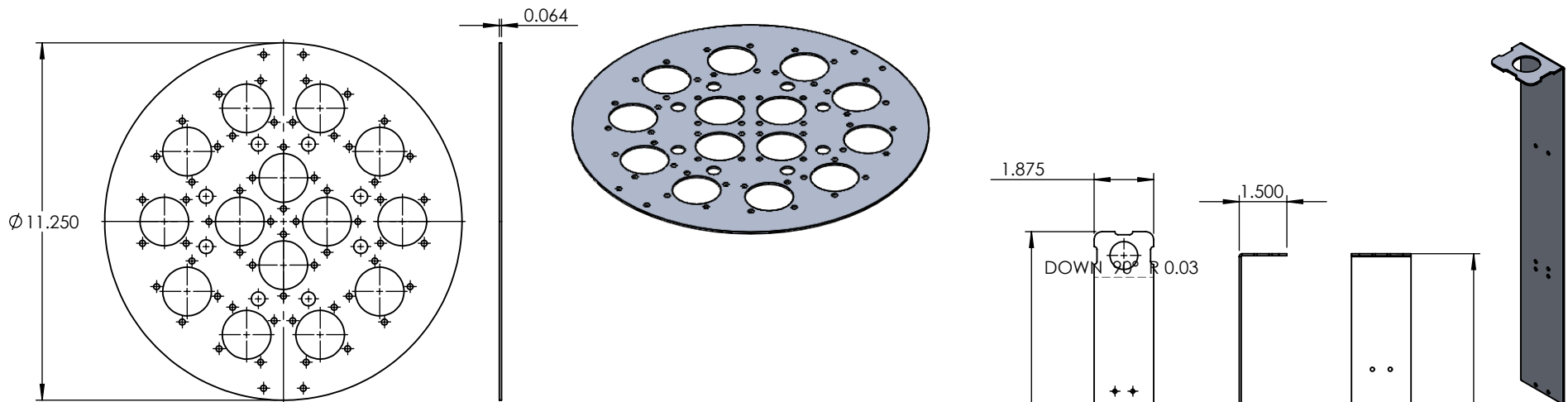

PROPRIETARY AND CONFIDENTIAL
 THE INFORMATION CONTAINED IN THIS DRAWING IS THE SOLE PROPERTY OF <INSERT COMPANY NAME HERE>. ANY REPRODUCTION IN PART OR AS A WHOLE WITHOUT THE WRITTEN PERMISSION OF <INSERT COMPANY NAME HERE> IS PROHIBITED.

		UNLESS OTHERWISE SPECIFIED:	NAME	DATE
		DIMENSIONS ARE IN INCHES	DRAWN	
		TOLERANCES:	CHECKED	
		FRACTIONAL ±	ENG APPR.	
		ANGULAR: MACH ± BEND ±	MFG APPR.	
		TWO PLACE DECIMAL ±	Q.A.	
		THREE PLACE DECIMAL ±	COMMENTS:	
		INTERPRET GEOMETRIC TOLERANCING PER:		
		MATERIAL		
		FINISH		
NEXT ASSY	USED ON			
APPLICATION	DO NOT SCALE DRAWING			

ALUMINUM 0.0635"		
TITLE:		
PST-DN-120LS-TBR-CFG-33X28-27K		
SIZE	DWG. NO.	REV
A		
SCALE: 1:5	WEIGHT:	SHEET 12 OF 12

5

4

3

2

1