

ITEM NO.	PART NUMBER	DESCRIPTION	QTY.	CUT
1	LIN-W270-BB-39IN-24W-SB-WF-35K-FRAME	22 GAUGE	1	
2	LIN-W270-BB-39IN-24W-SB-WF-35K-FRAME TAB	22 GAUGE	4	
3	LIN-W270-BB-39IN-24W-SB-WF-35K-BACKPLATE	22 GAUGE	1	
4	LIN-W270-BB-39IN-24W-SB-WF-35K-LED PLATE	22 GAUGE	1	
5	LIN-W270-BB-39IN-24W-SB-WF-35K-FIREPLATE	22 GAUGE	1	
6	LIN-W270-BB-39IN-24W-SB-WF-35K-FRONT PLATE STRAP	22 GAUGE	1	
7	LIN-W270-BB-39IN-24W-SB-WF-35K-FRONT STRAP TAB	22 GAUGE	4	
8	LIN-W270-BB-39IN-24W-SB-WF-35K-ACRYLIC	ACRYLIC	1	
9	ESPEN VEL29070MVH-1	DRIVER	1	
10	AltLED_PN1004RevD	LED	4	

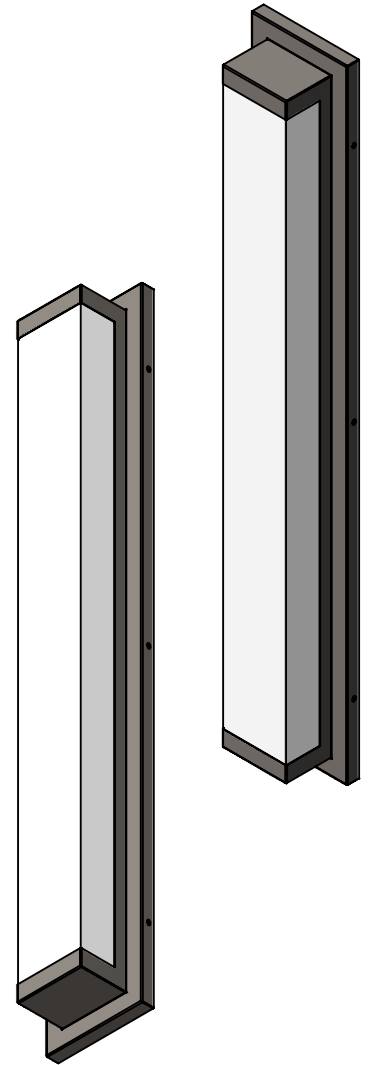
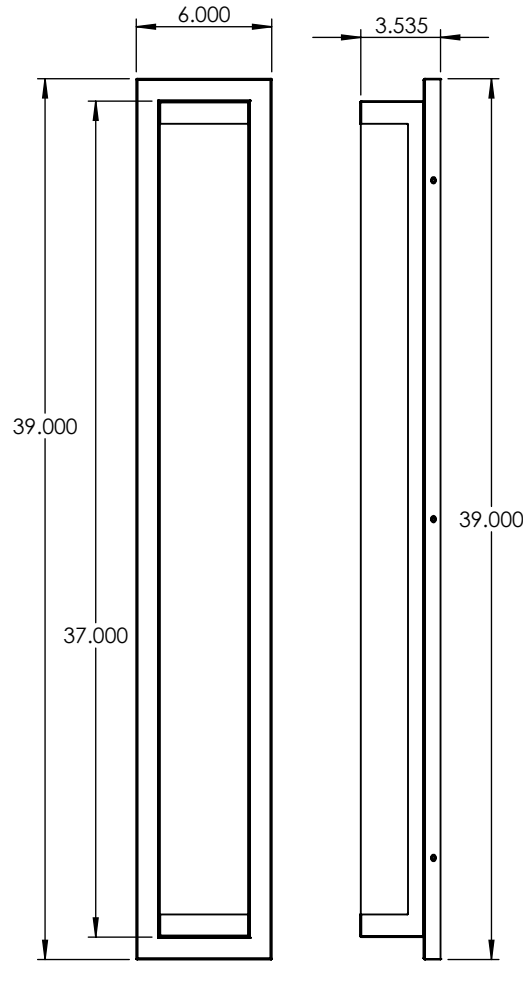
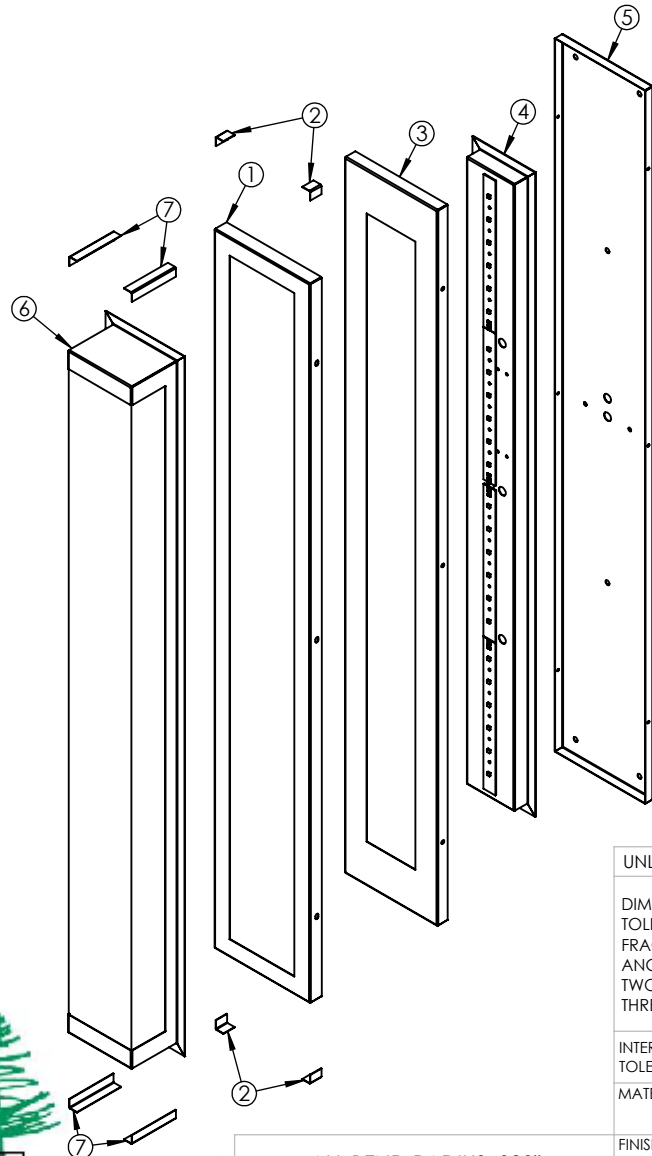

UNLESS OTHERWISE SPECIFIED:		NAME	DATE
DIMENSIONS ARE IN INCHES		DRAWN	
TOLERANCES:		CHECKED	
FRACTIONAL ± .003		ENG APPR.	
ANGULAR: MACH ± .01 BEND ±		MFG APPR.	
TWO PLACE DECIMAL ±		Q.A.	
THREE PLACE DECIMAL ±.001		COMMENTS:	
INTERPRET GEOMETRIC TOLERANCING PER:		TITLE:	
MATERIAL		LIN-W270-BB-39IN-24W-SB-WF-35K	
FINISH		SIZE	DWG. NO.
ALL BEND RADIUS .030"		<b>A</b> TICKET 25372	
APPLICATION		SCALE: 1:8.5	WEIGHT:
DO NOT SCALE DRAWING		SHEET 1 OF 8	

**EVERGREEN LIGHTING**

5

4

3

2

1

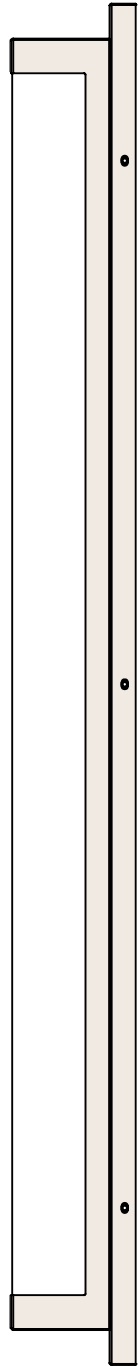
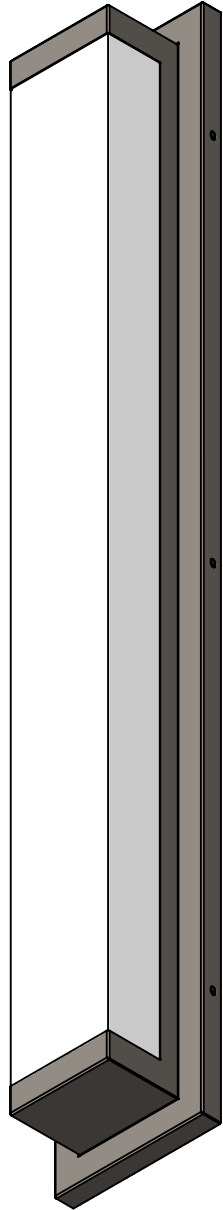
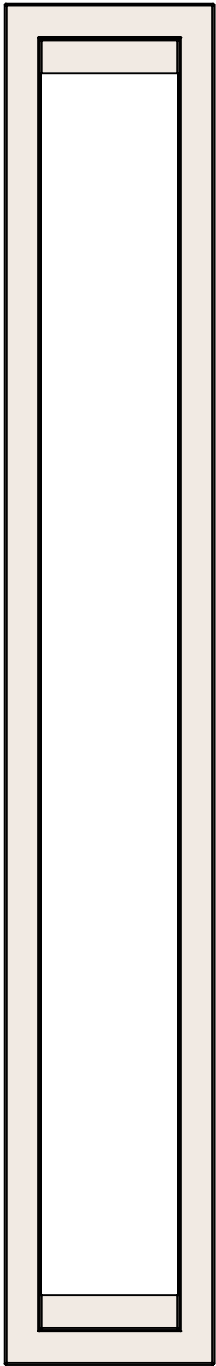

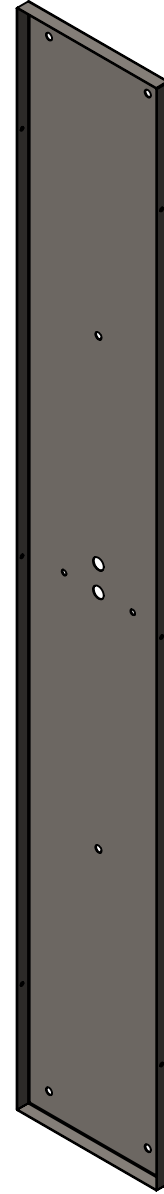
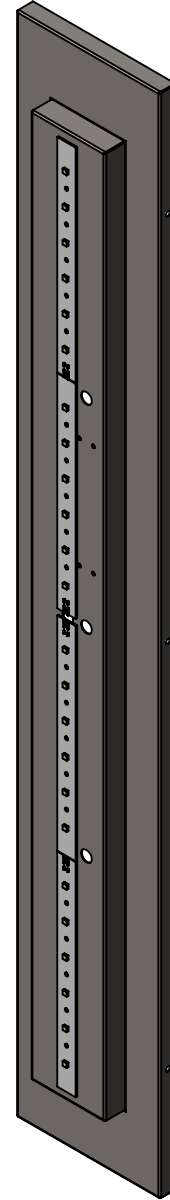
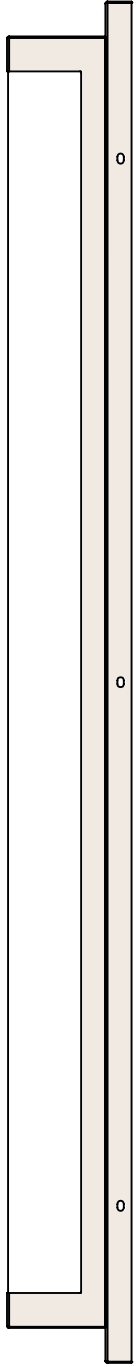

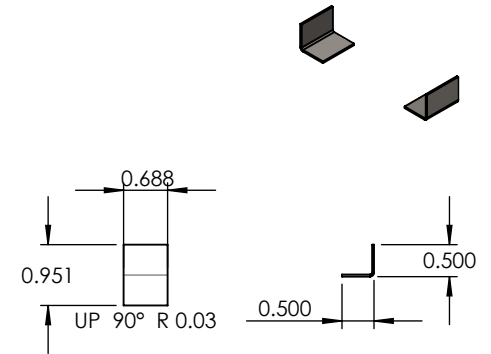
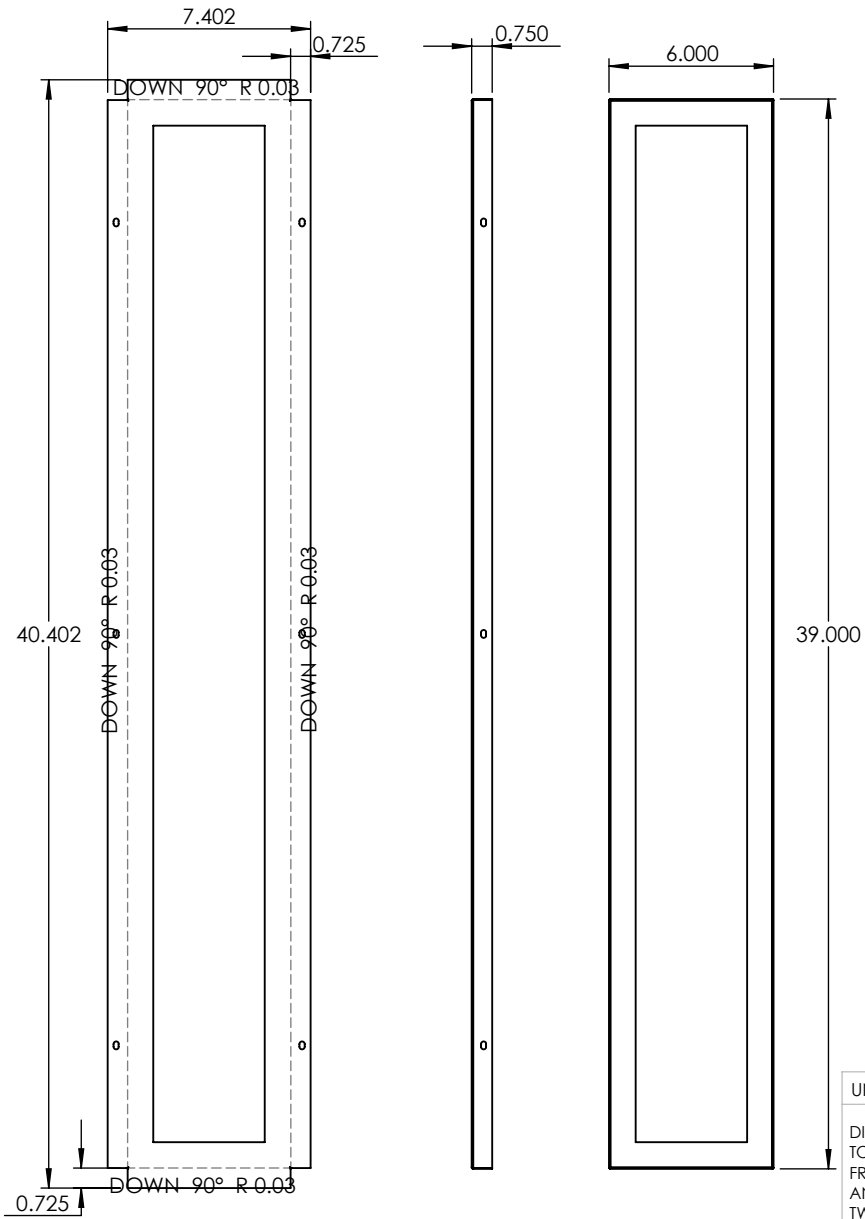

UNLESS OTHERWISE SPECIFIED:

DIMENSIONS ARE IN INCHES  
 TOLERANCES:  
 FRACTIONAL ±  
 ANGULAR: MACH ± BEND ±  
 TWO PLACE DECIMAL ±  
 THREE PLACE DECIMAL ±

INTERPRET GEOMETRIC  
 TOLERANCING PER:

MATERIAL

FINISH

DO NOT SCALE DRAWING

NAME

DATE

22 GAUGE

TITLE:

LIN-W270-BB-39IN-24W-SB-WF-35K

SIZE  
**A**

DWG. NO.

REV

SCALE: 1:7

WEIGHT:

SHEET 4 OF 8

**PROPRIETARY AND CONFIDENTIAL**

THE INFORMATION CONTAINED IN THIS DRAWING IS THE SOLE PROPERTY OF <INSERT COMPANY NAME HERE>. ANY REPRODUCTION IN PART OR AS A WHOLE WITHOUT THE WRITTEN PERMISSION OF <INSERT COMPANY NAME HERE> IS PROHIBITED.

NEXT ASSY	USED ON
APPLICATION	

5

4

3

2

1

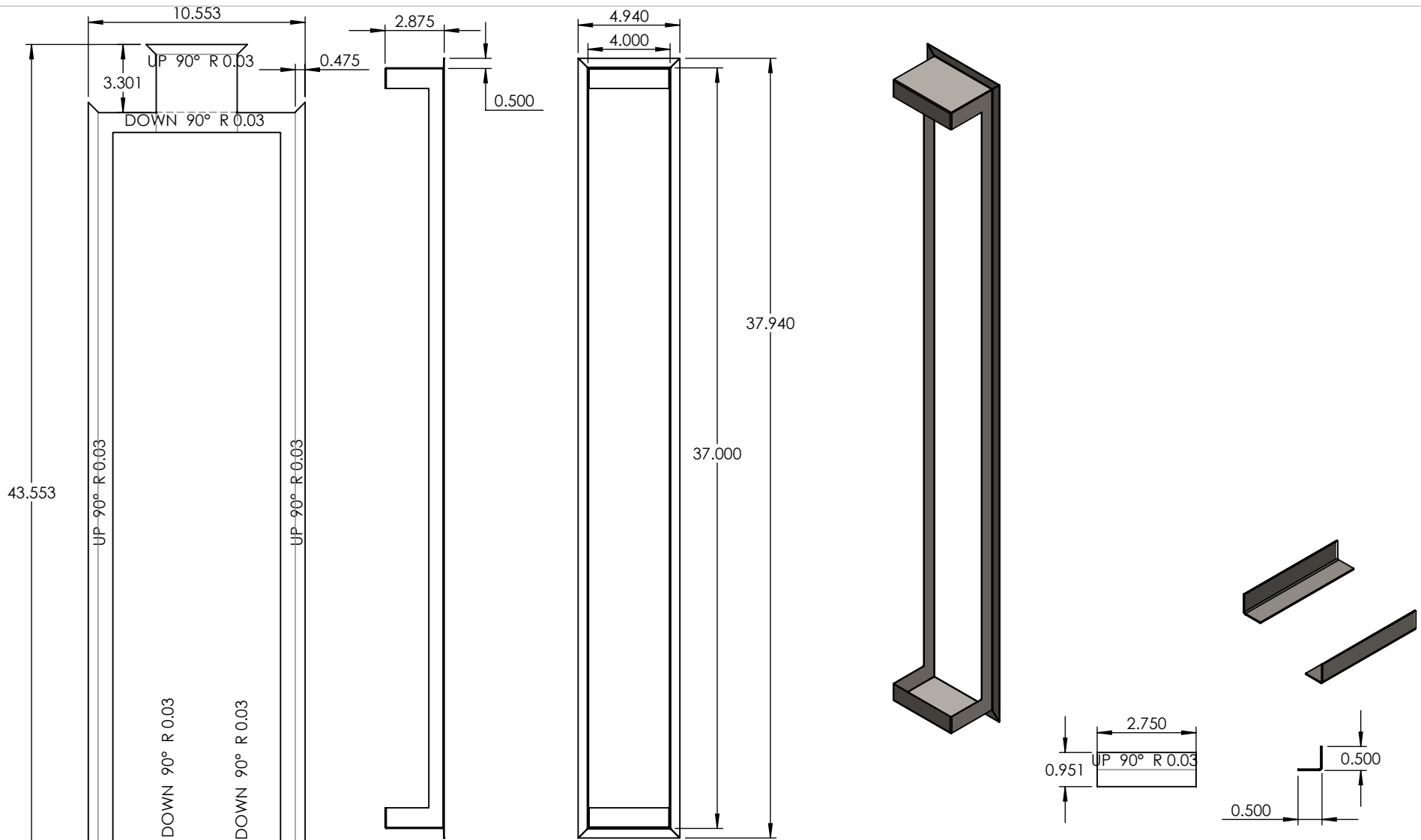

**PROPRIETARY AND CONFIDENTIAL**  
 THE INFORMATION CONTAINED IN THIS DRAWING IS THE SOLE PROPERTY OF <INSERT COMPANY NAME HERE>. ANY REPRODUCTION IN PART OR AS A WHOLE WITHOUT THE WRITTEN PERMISSION OF <INSERT COMPANY NAME HERE> IS PROHIBITED.

		UNLESS OTHERWISE SPECIFIED:	NAME	DATE
		DIMENSIONS ARE IN INCHES	DRAWN	
		TOLERANCES:	CHECKED	
		FRACTIONAL ±	ENG APPR.	
		ANGULAR: MACH ± BEND ±	MFG APPR.	
		TWO PLACE DECIMAL ±	Q.A.	
		THREE PLACE DECIMAL ±	COMMENTS:	
		INTERPRET GEOMETRIC TOLERANCING PER:		
		MATERIAL		
		FINISH		
NEXT ASSY	USED ON			
APPLICATION	DO NOT SCALE DRAWING			

22 GAUGE		
TITLE:		
LIN-W270-BB-39IN-24W-SB-WF-35K		
SIZE	DWG. NO.	REV
<b>A</b>		
SCALE: 1:7	WEIGHT:	SHEET 5 OF 8

5

4

3

2

1

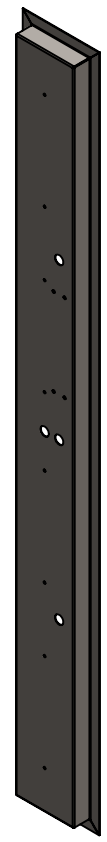
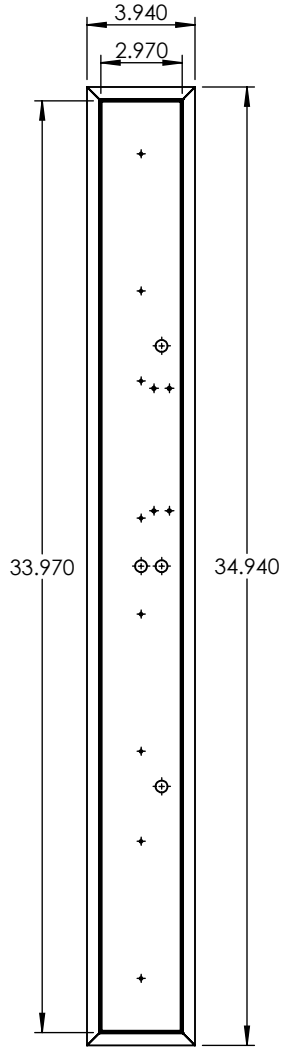
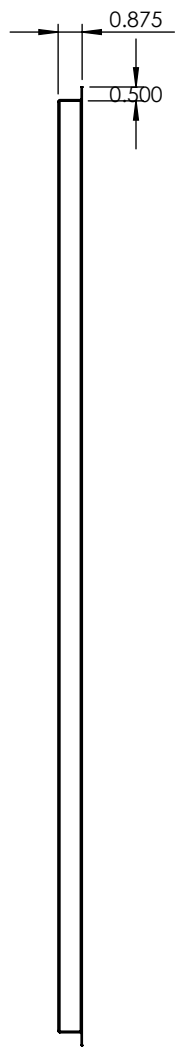
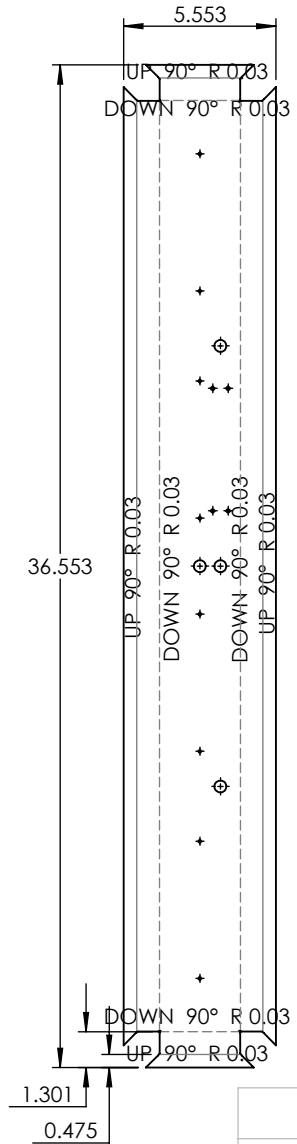

**PROPRIETARY AND CONFIDENTIAL**  
 THE INFORMATION CONTAINED IN THIS DRAWING IS THE SOLE PROPERTY OF <INSERT COMPANY NAME HERE>. ANY REPRODUCTION IN PART OR AS A WHOLE WITHOUT THE WRITTEN PERMISSION OF <INSERT COMPANY NAME HERE> IS PROHIBITED.

		UNLESS OTHERWISE SPECIFIED:		NAME	DATE
		DIMENSIONS ARE IN INCHES	DRAWN		
		TOLERANCES:	CHECKED		
		FRACTIONAL ±	ENG APPR.		
		ANGULAR: MACH ± BEND ±	MFG APPR.		
		TWO PLACE DECIMAL ±	Q.A.		
		THREE PLACE DECIMAL ±	COMMENTS:		
		INTERPRET GEOMETRIC TOLERANCING PER:			
		MATERIAL			
	NEXT ASSY	USED ON			
		FINISH			
	APPLICATION	DO NOT SCALE DRAWING			

22 GAUGE		
TITLE:		
LIN-W270-BB-39IN-24W-SB-WF-35K		
SIZE	DWG. NO.	REV
<b>A</b>		
SCALE: 1:7	WEIGHT:	SHEET 6 OF 8

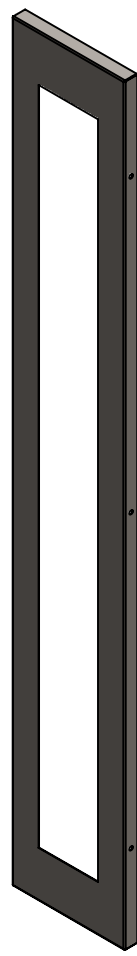
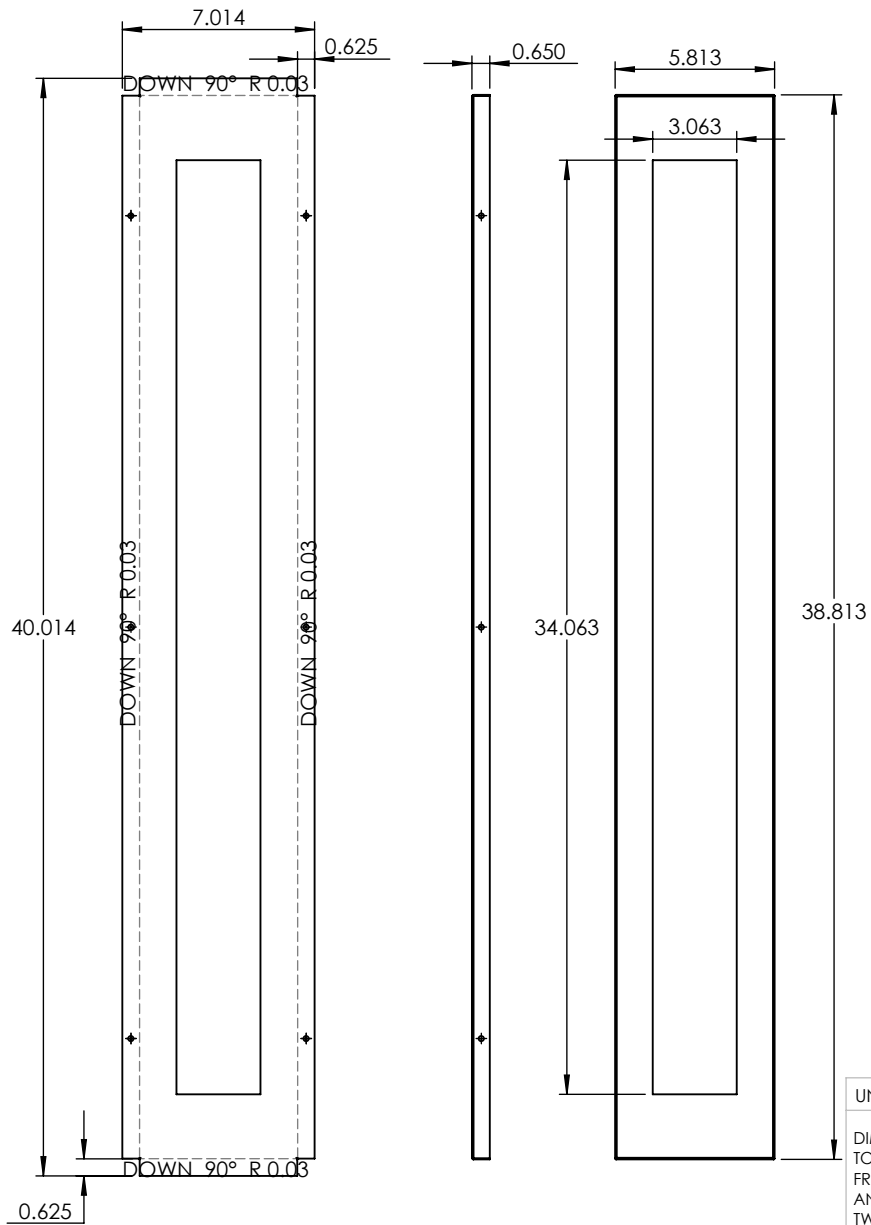

UNLESS OTHERWISE SPECIFIED:  
 DIMENSIONS ARE IN INCHES  
 TOLERANCES:  
 FRACTIONAL ±  
 ANGULAR: MACH ± BEND ±  
 TWO PLACE DECIMAL ±  
 THREE PLACE DECIMAL ±

INTERPRET GEOMETRIC TOLERANCING PER:  
 MATERIAL  
 FINISH  
 APPLICATION DO NOT SCALE DRAWING

	NAME	DATE
DRAWN		
CHECKED		
ENG APPR.		
MFG APPR.		
Q.A.		

COMMENTS:

<b>22 GAUGE</b>		
TITLE:		
LIN-W270-BB-39IN-24W-SB-WF-35K		
SIZE	DWG. NO.	REV
<b>A</b>		
SCALE: 1:7	WEIGHT:	SHEET 7 OF 8

**PROPRIETARY AND CONFIDENTIAL**  
 THE INFORMATION CONTAINED IN THIS DRAWING IS THE SOLE PROPERTY OF <INSERT COMPANY NAME HERE>. ANY REPRODUCTION IN PART OR AS A WHOLE WITHOUT THE WRITTEN PERMISSION OF <INSERT COMPANY NAME HERE> IS PROHIBITED.

NEXT ASSY	USED ON
APPLICATION	

5

4

3

2

1

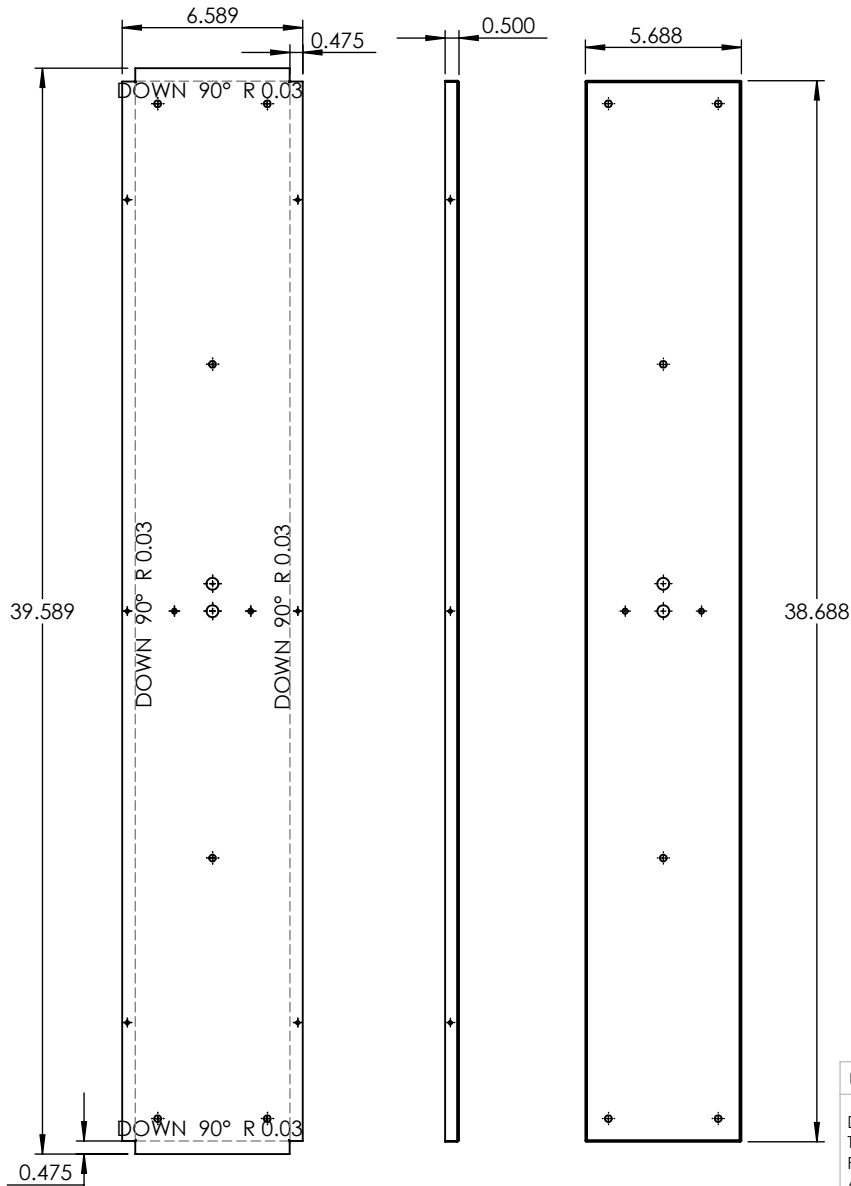

UNLESS OTHERWISE SPECIFIED:

DIMENSIONS ARE IN INCHES  
 TOLERANCES:  
 FRACTIONAL ±  
 ANGULAR: MACH ± BEND ±  
 TWO PLACE DECIMAL ±  
 THREE PLACE DECIMAL ±

INTERPRET GEOMETRIC  
 TOLERANCING PER:

MATERIAL

FINISH

DO NOT SCALE DRAWING

	NAME	DATE
DRAWN		
CHECKED		
ENG APPR.		
MFG APPR.		
Q.A.		
COMMENTS:		

22 GAUGE

TITLE:

LIN-W270-BB-39IN-24W-SB-WF-35K

SIZE	DWG. NO.	REV
<b>A</b>		
SCALE: 1:7	WEIGHT:	SHEET 8 OF 8

**PROPRIETARY AND CONFIDENTIAL**  
 THE INFORMATION CONTAINED IN THIS  
 DRAWING IS THE SOLE PROPERTY OF  
 <INSERT COMPANY NAME HERE>. ANY  
 REPRODUCTION IN PART OR AS A WHOLE  
 WITHOUT THE WRITTEN PERMISSION OF  
 <INSERT COMPANY NAME HERE> IS  
 PROHIBITED.

NEXT ASSY	USED ON	APPLICATION