

ITEM NO.	PART NUMBER	DESCRIPTION	QTY.	CUT
1	CANOPY	SPUN 18 GAUGE	1	
2	BWY-P-30"-100LED-TBR-WF-DIM-35K-TOP SPINNING	SPUN 18 GAUGE	1	
3	BWY-P-30"-100LED-TBR-WF-DIM-35K-BOTTOM SPINNING	SPUN 18 GAUGE	1	
4	BWY-P-30"-100LED-TBR-WF-DIM-35K-DOOR	SPUN 18 GAUGE	1	
5	BWY-P-30"-100LED-TBR-WF-DIM-35K-ONE PIECE RING STRAP	18 GAUGE	1	
6	BWY-P-30"-100LED-TBR-WF-DIM-35K-VERTICAL STRAP	18 GAUGE	4	
7	BWY-P-30"-100LED-TBR-WF-DIM-35K-SUPPORT CROSS BOTTOM	18 GAUGE	1	
8	BWY-P-30"-100LED-TBR-WF-DIM-35K-ROUND LED PLATE	ALUMINUM 0.0635"	1	
9	BWY-P-30"-100LED-TBR-WF-DIM-35K-0.500 INCH TUBE	1/2" ROUND ALUMINUM TUBE	4	
10	KTLD-25-UV-700-VDIM-LA1	DRIVER	6	
11	AItailed_PN110B_RevC	LED	10	

UNLESS OTHERWISE SPECIFIED:

DIMENSIONS ARE IN INCHES
 TOLERANCES:
 FRACTIONAL ± .003
 ANGULAR: MACH ± .01 BEND ±
 TWO PLACE DECIMAL ±
 THREE PLACE DECIMAL ± .001

INTERPRET GEOMETRIC
 TOLERANCING PER:

MATERIAL

FINISH

	NAME	DATE
DRAWN		
CHECKED		
ENG APPR.		
MFG APPR.		
Q.A.		
COMMENTS:		

TITLE:

BWY-P-30"-100LED-TBR-WF-DIM-35K

SIZE	DWG. NO.	REV
A	TICKET 25407	

SCALE: 1:16 WEIGHT: SHEET 1 OF 10



ALL BEND RADIUS .030"

APPLICATION

DO NOT SCALE DRAWING

5

4

3

2

1

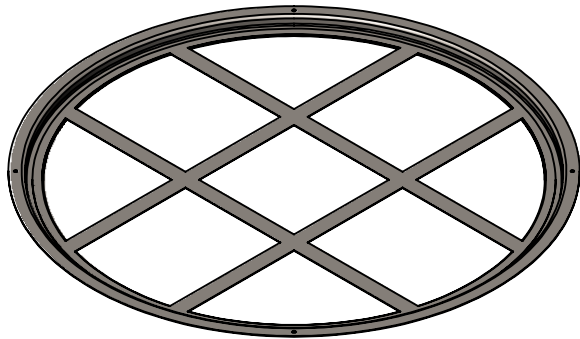
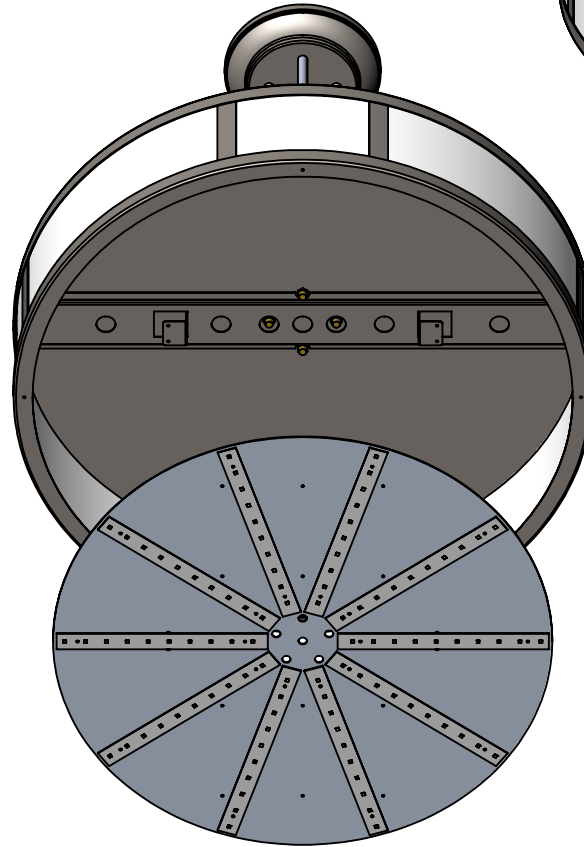
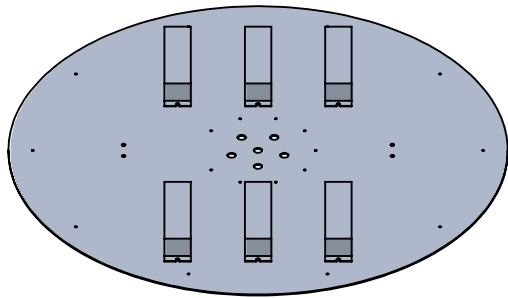
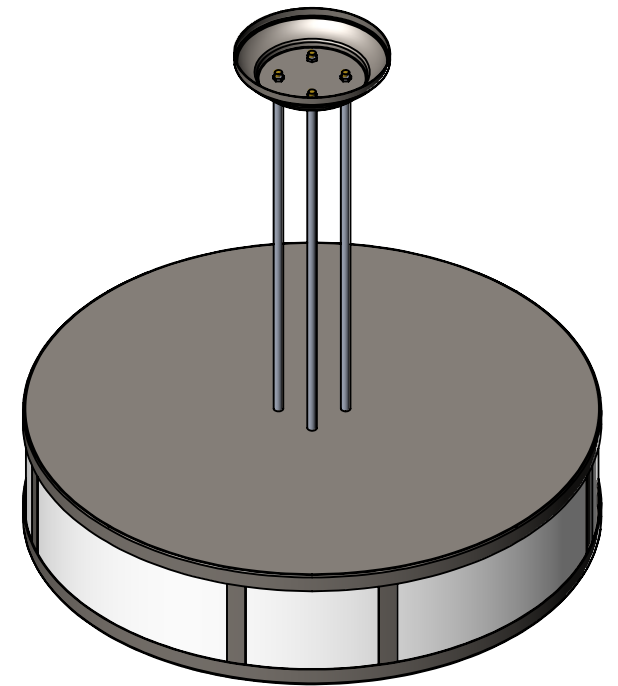
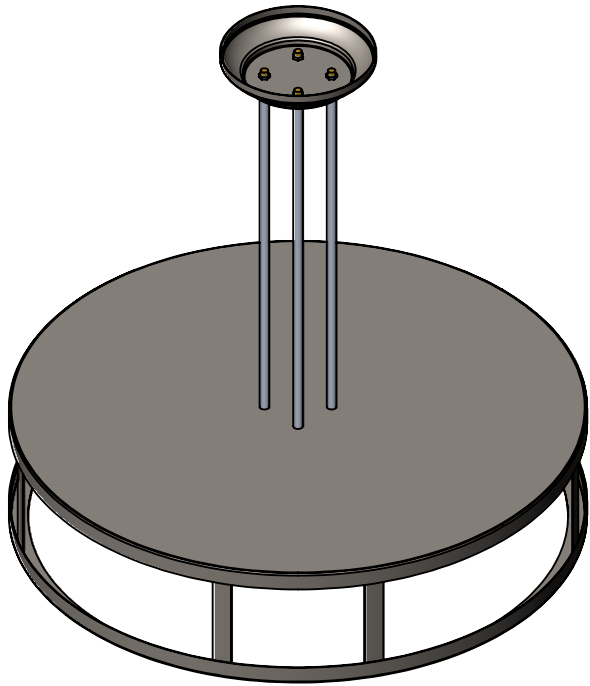

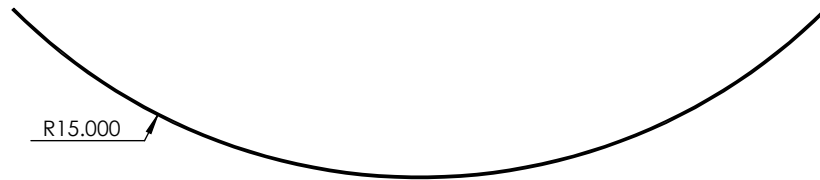
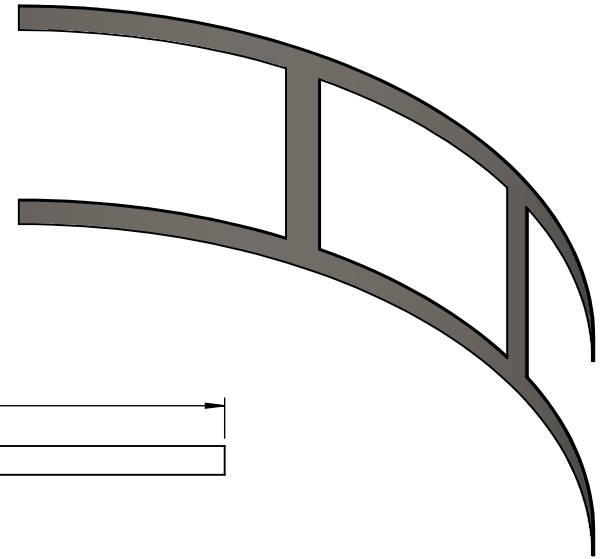
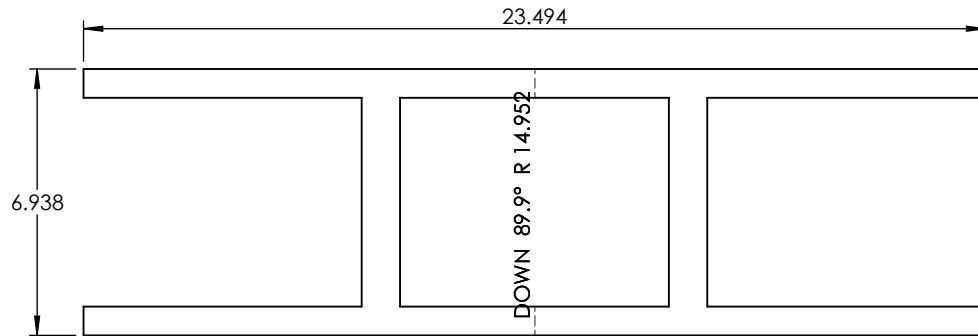
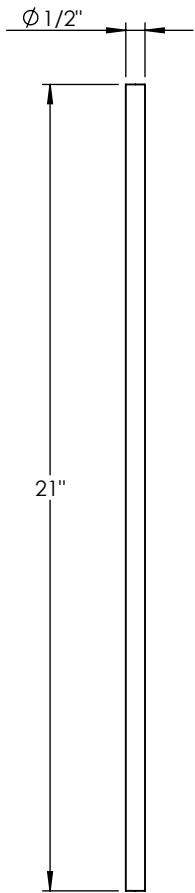

PROPRIETARY AND CONFIDENTIAL
 THE INFORMATION CONTAINED IN THIS DRAWING IS THE SOLE PROPERTY OF <INSERT COMPANY NAME HERE>. ANY REPRODUCTION IN PART OR AS A WHOLE WITHOUT THE WRITTEN PERMISSION OF <INSERT COMPANY NAME HERE> IS PROHIBITED.

		UNLESS OTHERWISE SPECIFIED:		NAME	DATE	18 GAUGE		
		DIMENSIONS ARE IN INCHES TOLERANCES: FRACTIONAL ± ANGULAR: MACH ± BEND ± TWO PLACE DECIMAL ± THREE PLACE DECIMAL ±	DRAWN			TITLE:		
		INTERPRET GEOMETRIC TOLERANCING PER:	CHECKED			BWY-P-30"-100LED-TBR-WF-DIM-35K		
		MATERIAL	ENG APPR.			SIZE	DWG. NO.	REV
NEXT ASSY	USED ON	FINISH	MFG APPR.			A		
APPLICATION		DO NOT SCALE DRAWING	Q.A.			SCALE: 1:5	WEIGHT:	SHEET 3 OF 10
			COMMENTS:					

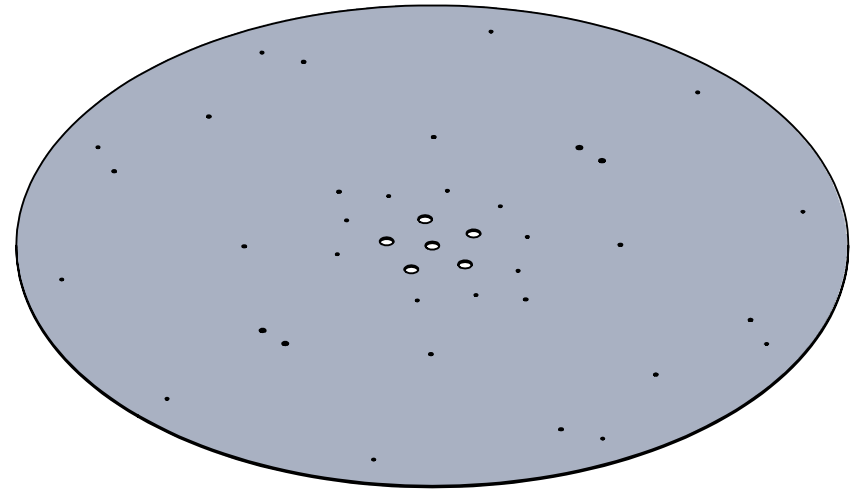
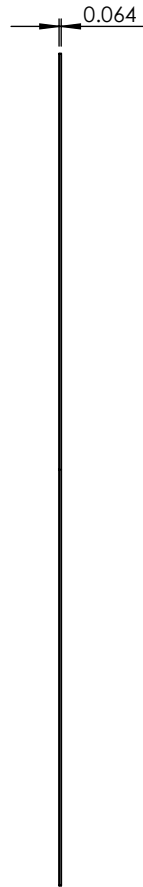
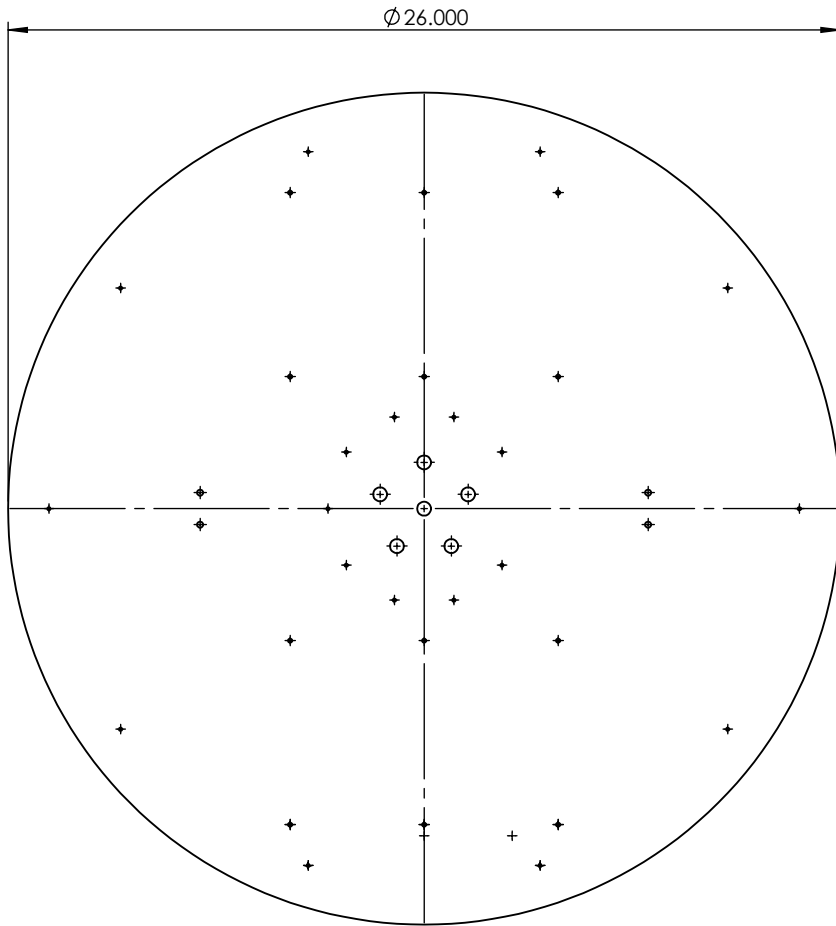

PROPRIETARY AND CONFIDENTIAL
 THE INFORMATION CONTAINED IN THIS DRAWING IS THE SOLE PROPERTY OF <INSERT COMPANY NAME HERE>. ANY REPRODUCTION IN PART OR AS A WHOLE WITHOUT THE WRITTEN PERMISSION OF <INSERT COMPANY NAME HERE> IS PROHIBITED.

		UNLESS OTHERWISE SPECIFIED:		NAME	DATE	ALUMINUM 0.0635"		
		DIMENSIONS ARE IN INCHES TOLERANCES: FRACTIONAL ± ANGULAR: MACH ± BEND ± TWO PLACE DECIMAL ± THREE PLACE DECIMAL ±	DRAWN					TITLE:
		INTERPRET GEOMETRIC TOLERANCING PER:	CHECKED			BWY-P-30"-100LED-TBR-WF-DIM-35K		
		MATERIAL	ENG APPR.					
		FINISH	MFG APPR.			SIZE	DWG. NO.	REV
NEXT ASSY	USED ON		Q.A.			A		
APPLICATION		DO NOT SCALE DRAWING	COMMENTS:				SCALE: 1:6	WEIGHT:

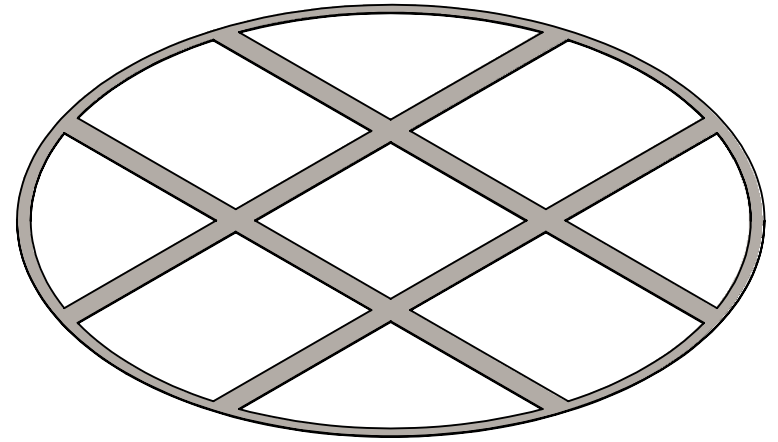
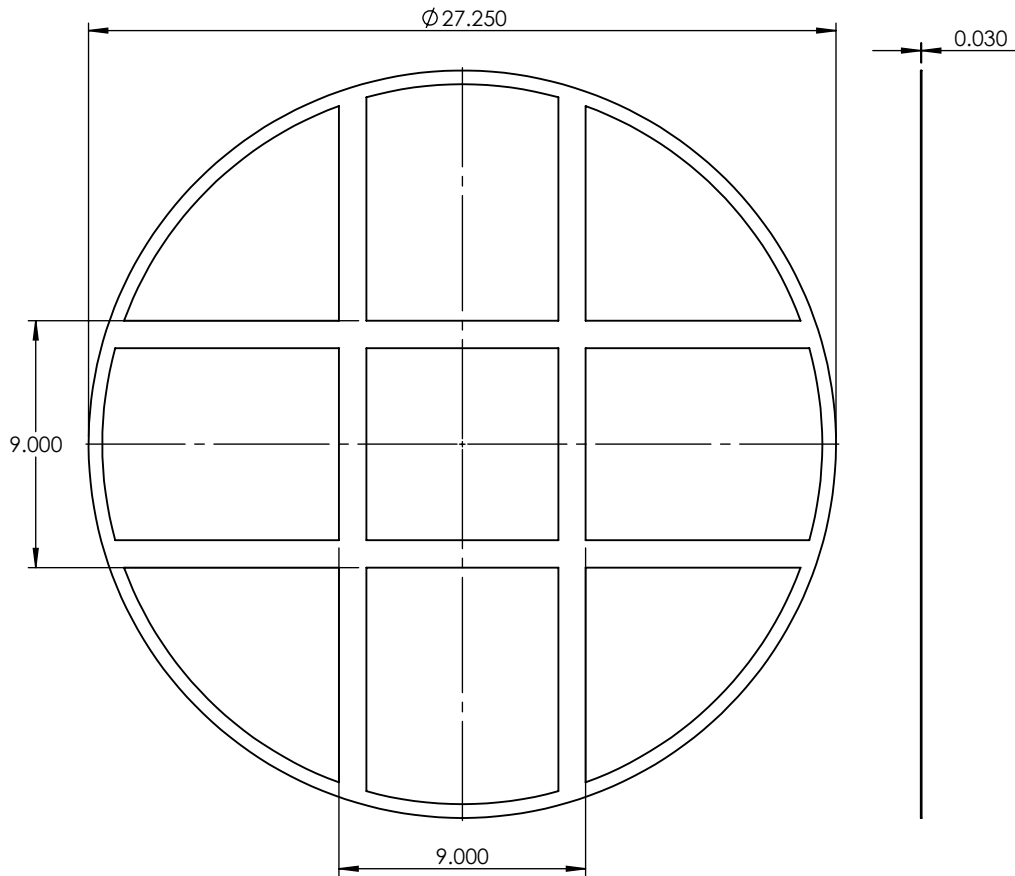

PROPRIETARY AND CONFIDENTIAL
 THE INFORMATION CONTAINED IN THIS DRAWING IS THE SOLE PROPERTY OF <INSERT COMPANY NAME HERE>. ANY REPRODUCTION IN PART OR AS A WHOLE WITHOUT THE WRITTEN PERMISSION OF <INSERT COMPANY NAME HERE> IS PROHIBITED.

		UNLESS OTHERWISE SPECIFIED:	NAME	DATE	18 GAUGE	
		DIMENSIONS ARE IN INCHES TOLERANCES: FRACTIONAL \pm ANGULAR: MACH \pm BEND \pm TWO PLACE DECIMAL \pm THREE PLACE DECIMAL \pm	DRAWN			
		INTERPRET GEOMETRIC TOLERANCING PER:	CHECKED		BWY-P-30"-100LED-TBR-WF-DIM-35K	
		MATERIAL	ENG APPR.			
		FINISH	MFG APPR.		Q.A.	
NEXT ASSY	USED ON		COMMENTS:		SIZE	DWG. NO.
APPLICATION		DO NOT SCALE DRAWING			A	REV
					SCALE: 1:7	WEIGHT:
					SHEET 6 OF 10	

5

4

3

2

1

ITEM NO.	PART NUMBER	DESCRIPTION	QTY.
1	BWY-P-30"-100LED-TBR-WF-DIM-35K-TOP SPINNING	SPUN 18 GAUGE	2

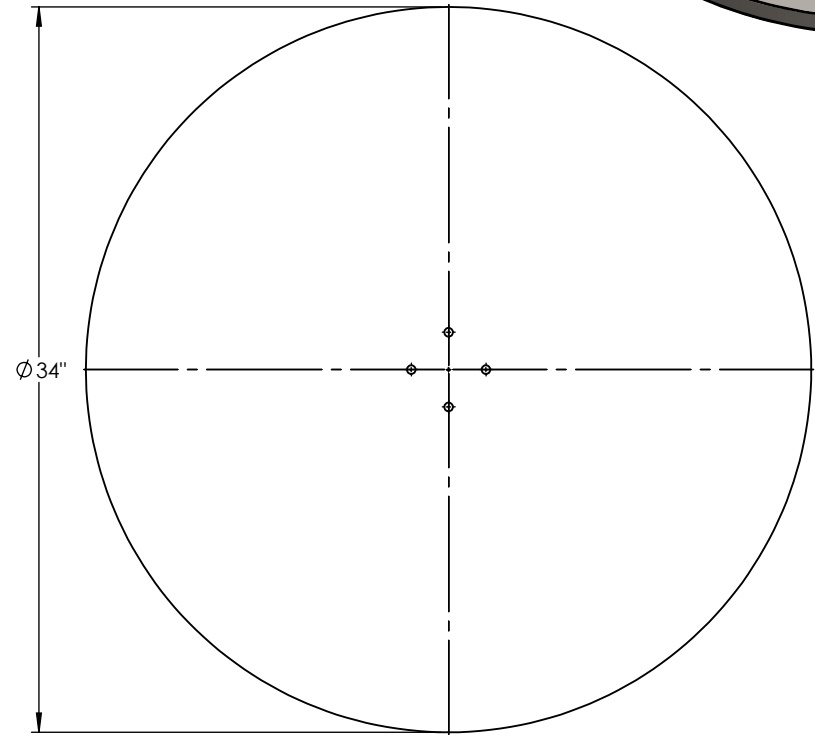
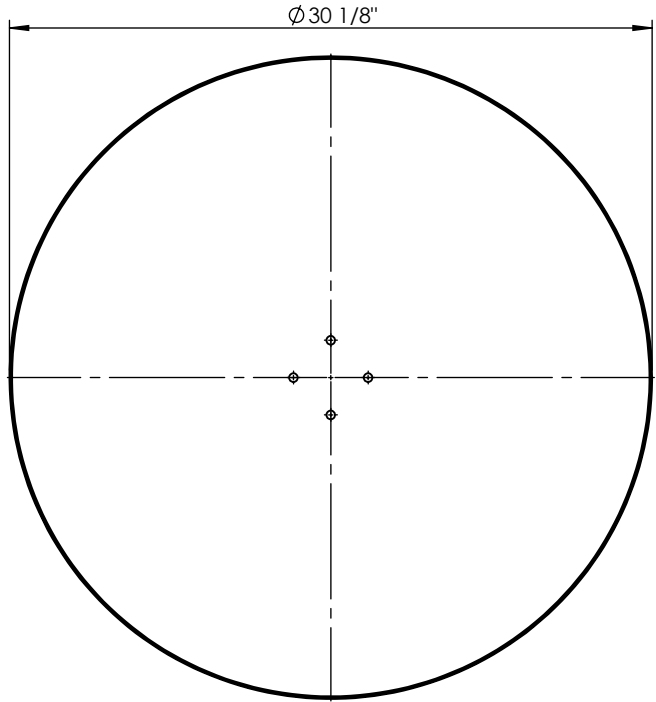
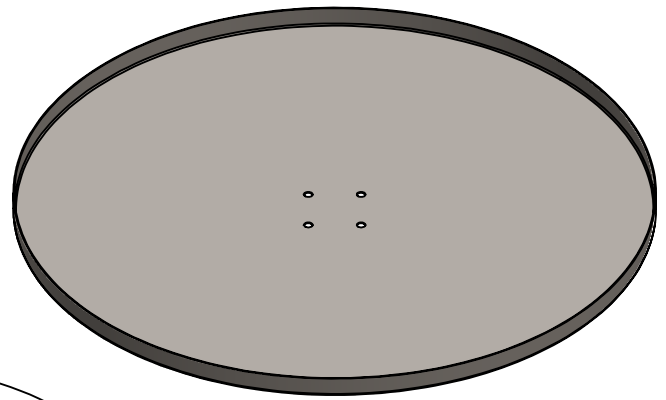
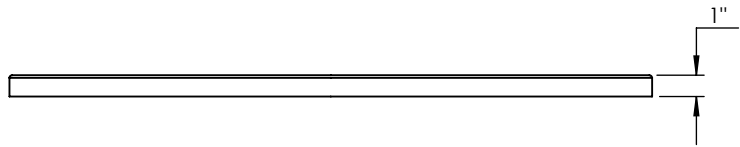

UNLESS OTHERWISE SPECIFIED:

DIMENSIONS ARE IN INCHES
 TOLERANCES:
 FRACTIONAL ±
 ANGULAR: MACH ± BEND ±
 TWO PLACE DECIMAL ±
 THREE PLACE DECIMAL ±

INTERPRET GEOMETRIC TOLERANCING PER:

MATERIAL

FINISH

DO NOT SCALE DRAWING

NAME DATE

DRAWN		
CHECKED		
ENG APPR.		
MFG APPR.		
Q.A.		
COMMENTS:		

SPUN 18 GAUGE

TITLE:

BWY-P-30"-100LED-TBR-WF-DIM-35K

SIZE	DWG. NO.	REV
A		
SCALE: 1:9	WEIGHT:	SHEET 7 OF 10

PROPRIETARY AND CONFIDENTIAL
 THE INFORMATION CONTAINED IN THIS DRAWING IS THE SOLE PROPERTY OF <INSERT COMPANY NAME HERE>. ANY REPRODUCTION IN PART OR AS A WHOLE WITHOUT THE WRITTEN PERMISSION OF <INSERT COMPANY NAME HERE> IS PROHIBITED.

NEXT ASSY	USED ON
APPLICATION	

ITEM NO.	PART NUMBER	DESCRIPTION	QTY.
1	BWY-P-30"-100LED-TBR-WF-DIM-35K-BOTTOM SPINNING	SPUN 18 GAUGE	1

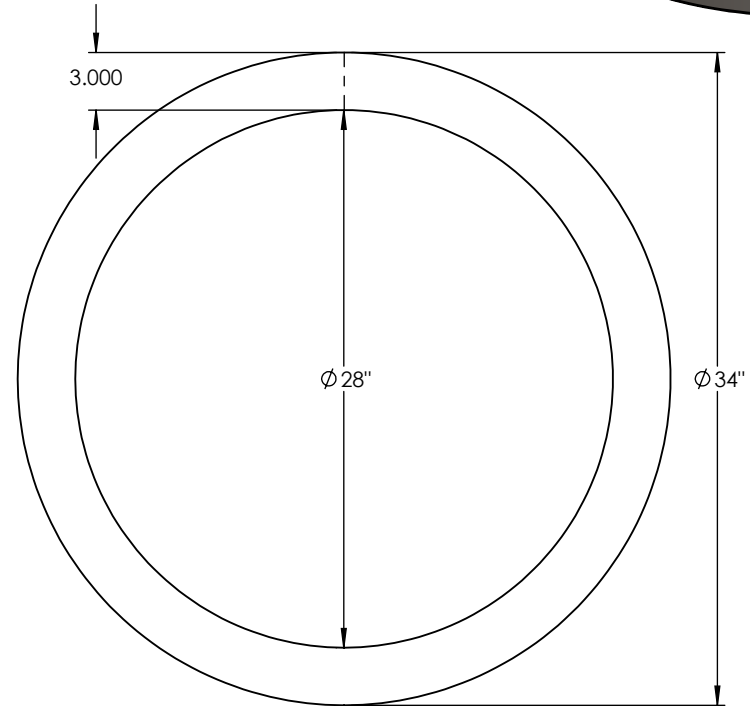
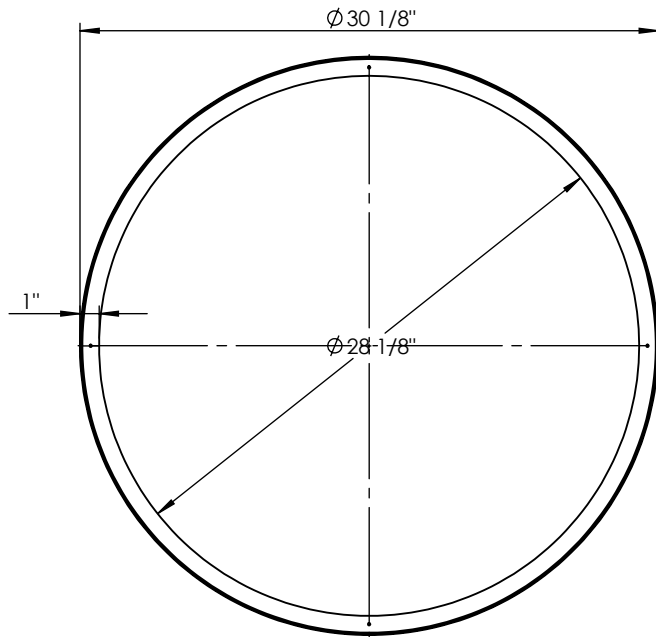
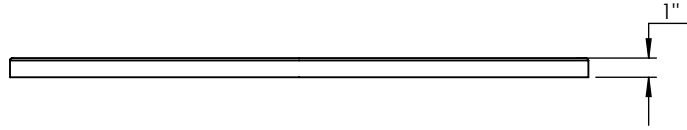
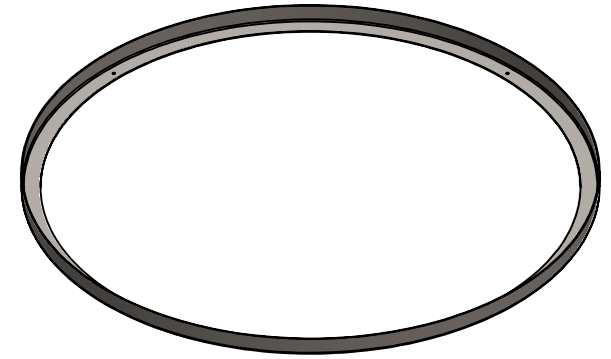

UNLESS OTHERWISE SPECIFIED: DIMENSIONS ARE IN INCHES TOLERANCES: FRACTIONAL ± ANGULAR: MACH ± BEND ± TWO PLACE DECIMAL ± THREE PLACE DECIMAL ±		NAME	DATE	SPUN 18 GAUGE		
	DRAWN					TITLE:
	CHECKED			BWY-P-30"-100LED-TBR-WF-DIM-35K		
	ENG APPR.					
INTERPRET GEOMETRIC TOLERANCING PER:				Q.A.		
MATERIAL				COMMENTS:		
FINISH				SIZE	DWG. NO.	REV
				A		
				SCALE: 1:10	WEIGHT:	SHEET 8 OF 10

PROPRIETARY AND CONFIDENTIAL
THE INFORMATION CONTAINED IN THIS DRAWING IS THE SOLE PROPERTY OF <INSERT COMPANY NAME HERE>. ANY REPRODUCTION IN PART OR AS A WHOLE WITHOUT THE WRITTEN PERMISSION OF <INSERT COMPANY NAME HERE> IS PROHIBITED.

NEXT ASSY	USED ON
APPLICATION	

DO NOT SCALE DRAWING

ITEM NO.	PART NUMBER	DESCRIPTION	QTY.
1	BWY-P-30"-100LED-TBR-WF-DIM-35K-DOOR	SPUN 18 GAUGE	1

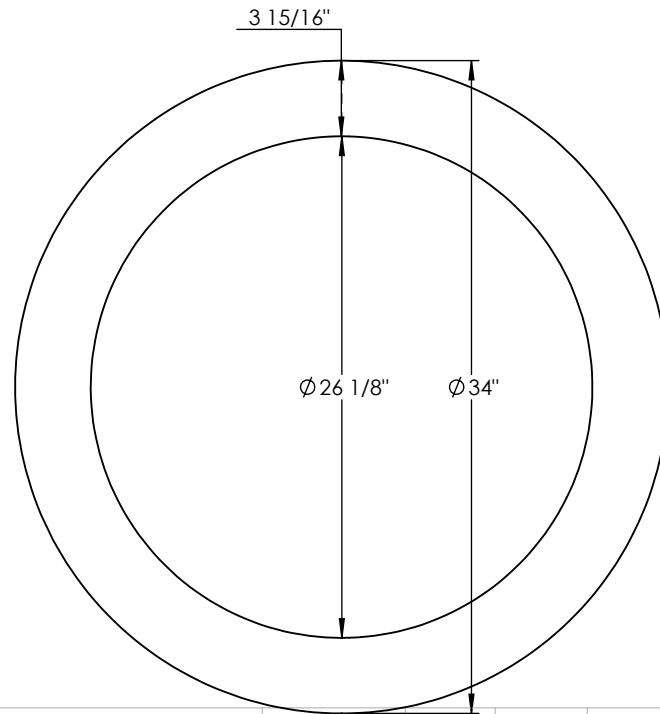
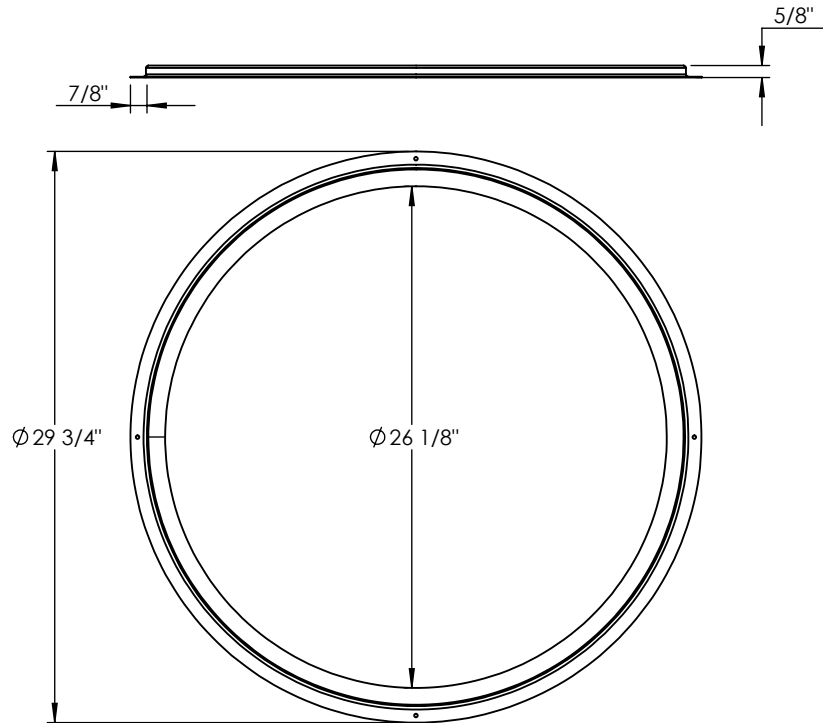
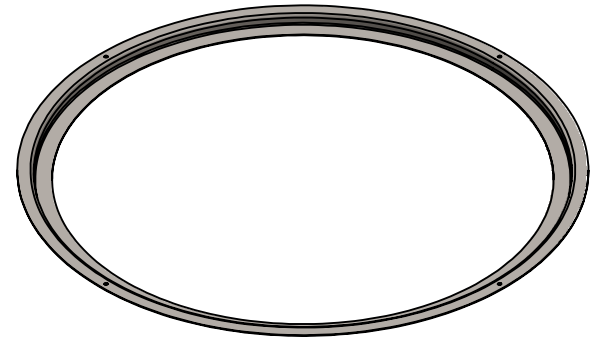

UNLESS OTHERWISE SPECIFIED: DIMENSIONS ARE IN INCHES TOLERANCES: FRACTIONAL ± ANGULAR: MACH ± BEND ± TWO PLACE DECIMAL ± THREE PLACE DECIMAL ±	NAME	DATE	SPUN 18 GAUGE			
	DRAWN				TITLE:	
	CHECKED		BWY-P-30"-100LED-TBR-WF-DIM-35K			
	ENG APPR.					
MFG APPR.		Q.A.	COMMENTS:	SIZE	DWG. NO.	REV
INTERPRET GEOMETRIC TOLERANCING PER:				A		
MATERIAL				SCALE: 1:10	WEIGHT:	SHEET 9 OF 10
FINISH						
DO NOT SCALE DRAWING						

PROPRIETARY AND CONFIDENTIAL
THE INFORMATION CONTAINED IN THIS DRAWING IS THE SOLE PROPERTY OF <INSERT COMPANY NAME HERE>. ANY REPRODUCTION IN PART OR AS A WHOLE WITHOUT THE WRITTEN PERMISSION OF <INSERT COMPANY NAME HERE> IS PROHIBITED.

NEXT ASSY	USED ON
APPLICATION	

ITEM NO.	PART NUMBER	DESCRIPTION	QTY.
1	CANOPY	SPUN 18 GAUGE	1

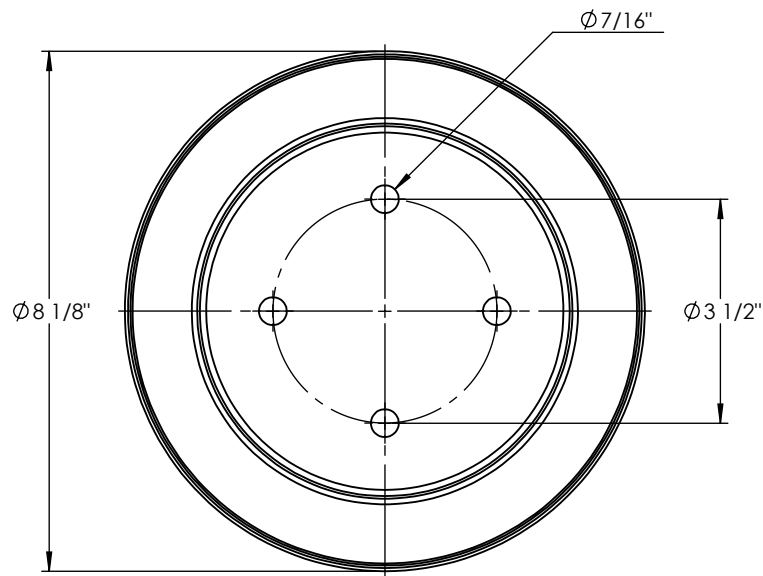
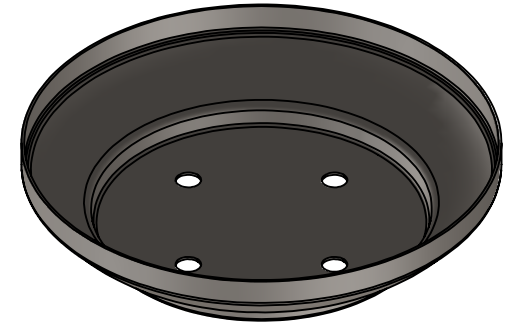
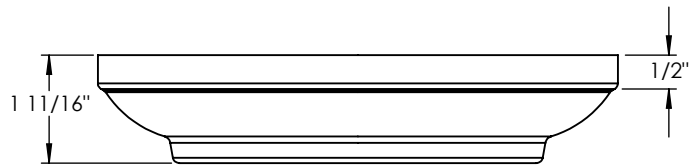

PROPRIETARY AND CONFIDENTIAL
 THE INFORMATION CONTAINED IN THIS DRAWING IS THE SOLE PROPERTY OF <INSERT COMPANY NAME HERE>. ANY REPRODUCTION IN PART OR AS A WHOLE WITHOUT THE WRITTEN PERMISSION OF <INSERT COMPANY NAME HERE> IS PROHIBITED.

		UNLESS OTHERWISE SPECIFIED:		NAME	DATE	SPUN 18 GAUGE		
		DIMENSIONS ARE IN INCHES TOLERANCES: FRACTIONAL ± ANGULAR: MACH ± BEND ± TWO PLACE DECIMAL ± THREE PLACE DECIMAL ±	DRAWN					TITLE:
		INTERPRET GEOMETRIC TOLERANCING PER:				BWY-P-30"-100LED-TBR-WF-DIM-35K		
		MATERIAL		ENG APPR.		SIZE	DWG. NO.	REV
	NEXT ASSY	USED ON	FINISH	MFG APPR.		A		
		APPLICATION	DO NOT SCALE DRAWING	Q.A.		SCALE: 1:3	WEIGHT:	SHEET 10 OF 10
				COMMENTS:				