

ITEM NO.	PART NUMBER	DESCRIPTION	QTY.	CUT
1	LDSCP-BOL37-4LED-AB-CFA-TOP SPINNING	SPUN ALUMINUM 0.125"	1	
2	LDSCP-BOL37-4LED-AB-CFA-BOTTOM SPINNING	SPUN ALUMINUM 0.125"	1	
3	LDSCP-BOL37-4LED-AB-CFA-DRIVER BRACKET	ALUMINUM 0.0635"	1	
4	LDSCP-BOL37-4LED-AB-CFA-LED SUPPORT BRACKET	ALUMINUM 0.0635"	1	
5	LDSCP-BOL37-4LED-AB-CFA-LED REFLECTOR	ALUMINUM 0.0635"	1	
6	LDSCP-BOL37-4LED-AB-CFA-ANCHOR COVER BRACKET	ALUMINUM 0.0635"	2	
7	LDSCP-BOL37-4LED-AB-CFA-TOP PLATE	ALUMINUM 0.250" PLATE	1	
8	LDSCP-BOL37-4LED-AB-CFA-NECK BRACKET	ALUMINUM 0.250" PLATE	4	
9	LDSCP-BOL37-4LED-AB-CFA-FIN ACCENT	ALUMINUM 0.500" PLATE	4	
10	LDSCP-BOL37-4LED-AB-CFA-8" SPUN SPHERE	SPUN ALUMINUM 0.125"	1	
11	LDSCP-BOL37-4LED-AB-CFA-BASE PLATE	ALUMINUM 0.500" PLATE	1	
12	LDSCP-BOL37-4LED-AB-CFA-TUBE FIN 2.0	ALUMINUM 1"X1/2" TUBE	4	
13	LDSCP-BOL37-4LED-AB-CFA-FIN STRIP	1/2"X1/4" ALUMINUM BAR	4	
14	LDSCP-BOL37-4LED-AB-CFA-ROUND COVER	SPUN ALUMINUM 0.080"	2	
15	LDSCP-BOL37-4LED-AB-CFA-CYLINDER	5" ALUMINUM CYLINDER	1	
16	LDSCP-BOL37-4LED-AB-CFA-ACRYLIC	ACRYLIC	1	
17	EspenTECH_120277V_SKU808076	DRIVER	1	
18	AltqILED_PCN_D1000_105B	LED	1	
20	43 MM HEAT SINK	HEAT SINK	1	

UNLESS OTHERWISE SPECIFIED:

DIMENSIONS ARE IN INCHES
 TOLERANCES:
 FRACTIONAL ± .003
 ANGULAR: MACH ± .01 BEND ±
 TWO PLACE DECIMAL ±
 THREE PLACE DECIMAL ± .001

INTERPRET GEOMETRIC
 TOLERANCING PER:
 MATERIAL

FINISH

NAME DATE

DRAWN
 CHECKED
 ENG APPR.
 MFG APPR.

Q.A.
 COMMENTS:

TITLE:

LDSCP-BOL37-4LED-AB-CFA

SIZE DWG. NO.

A TICKET 25415

REV

SCALE: 1:10 WEIGHT:

SHEET 1 OF 15

ALL BEND RADIUS .030"

APPLICATION

DO NOT SCALE DRAWING



EVERGREEN LIGHTING

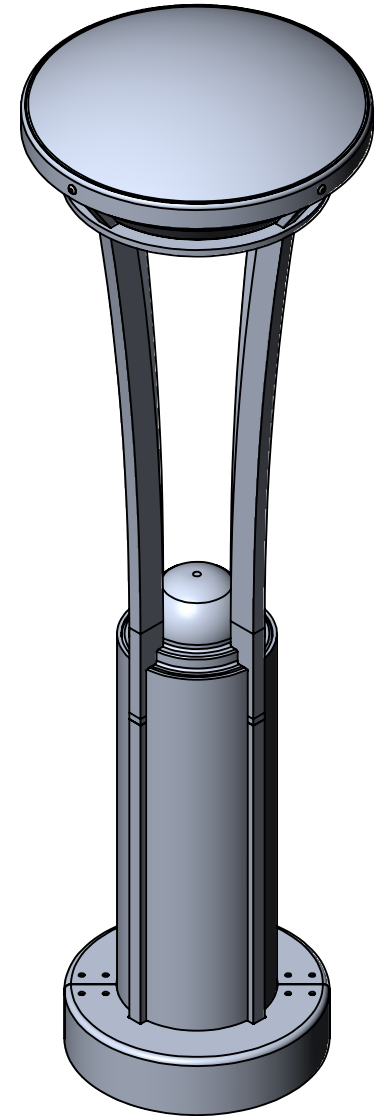
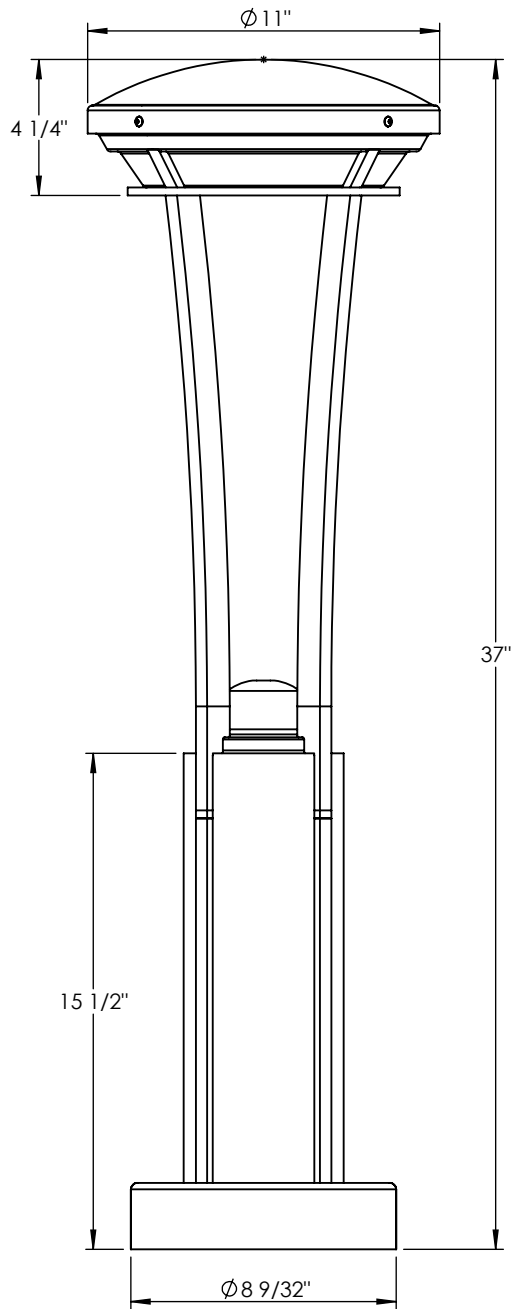

UNLESS OTHERWISE SPECIFIED:		NAME	DATE	TITLE:
DIMENSIONS ARE IN INCHES		DRAWN		
TOLERANCES:		CHECKED		LDSCP-BOL37-4LED-AB-CFA
FRACTIONAL $\pm .003$		ENG APPR.		
ANGULAR: MACH $\pm .01$ BEND \pm		MFG APPR.		
TWO PLACE DECIMAL \pm		Q.A.		SIZE DWG. NO. REV
THREE PLACE DECIMAL $\pm .001$		COMMENTS:		A TICKET 23345
INTERPRET GEOMETRIC TOLERANCING PER:				SCALE: 1:6 WEIGHT: SHEET 2 OF 15
MATERIAL				
FINISH				



ALL BEND RADIUS .030"

APPLICATION

DO NOT SCALE DRAWING

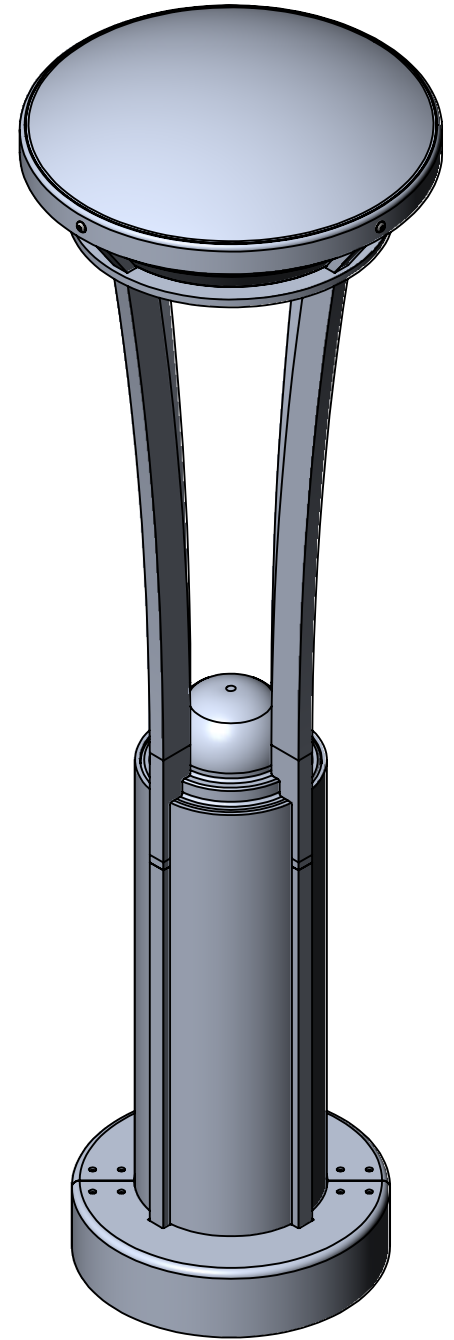
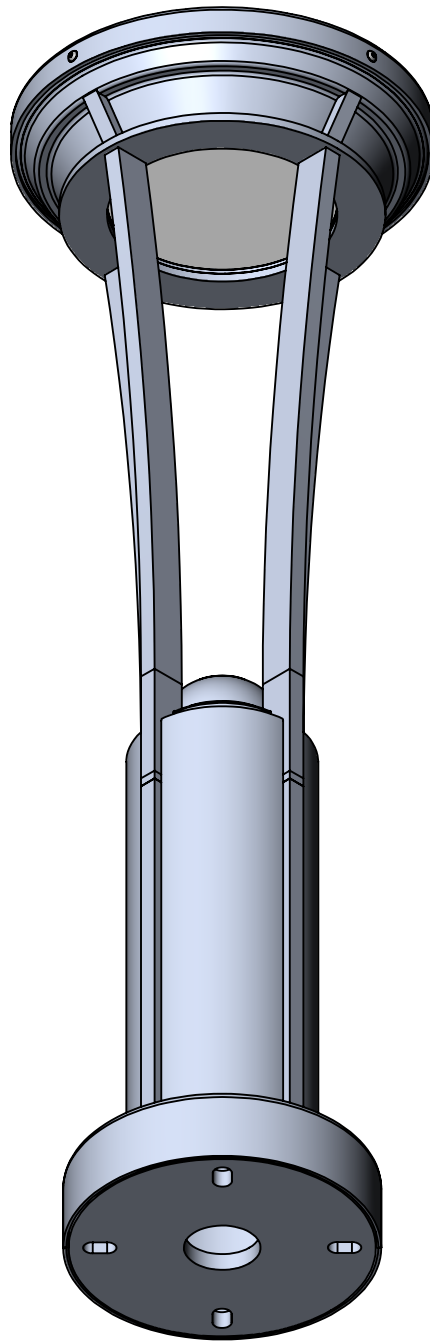
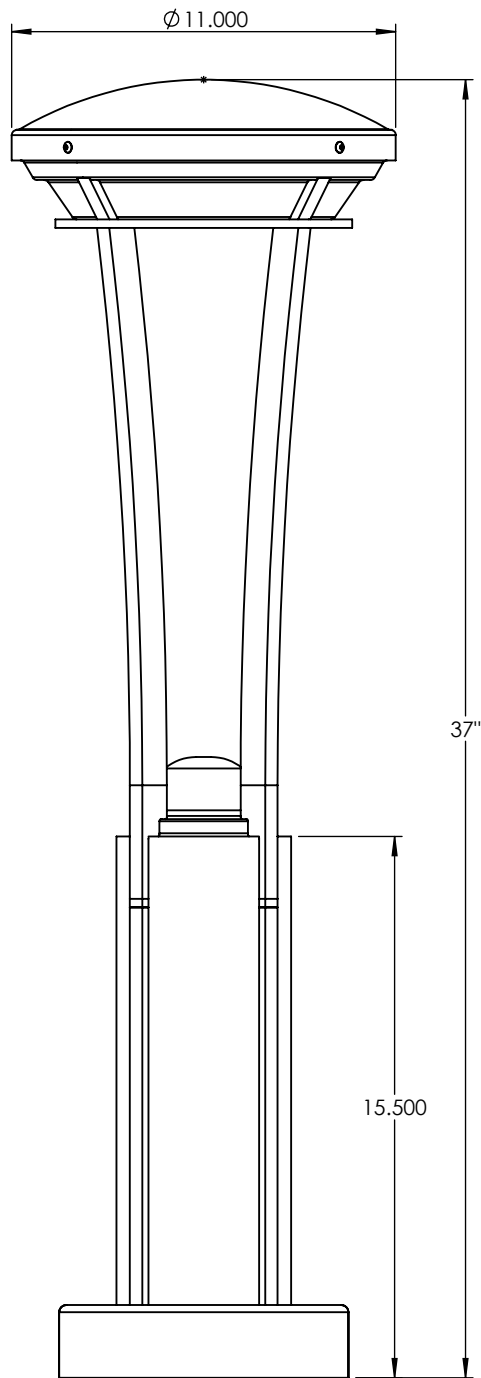

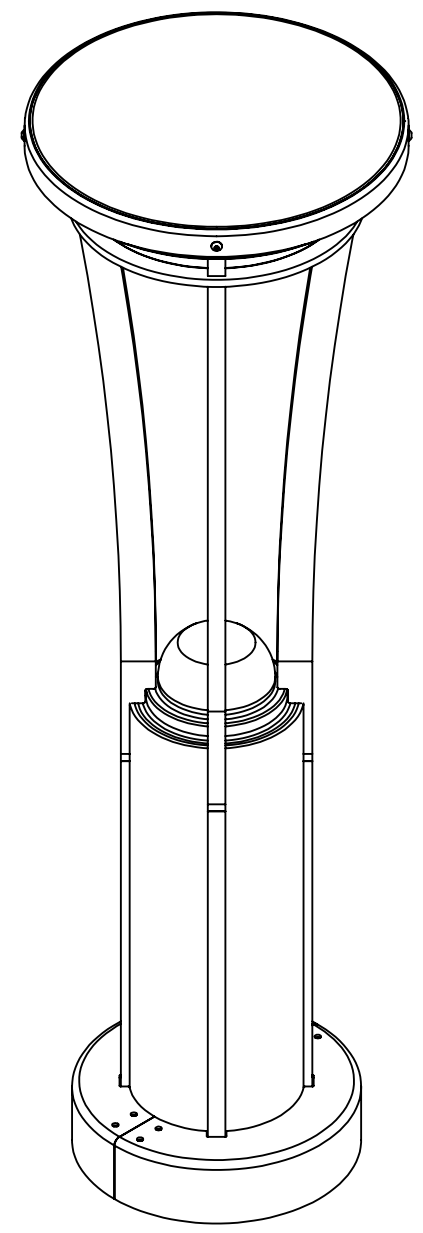
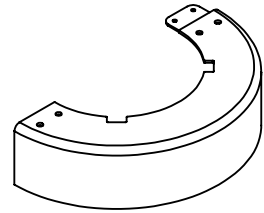
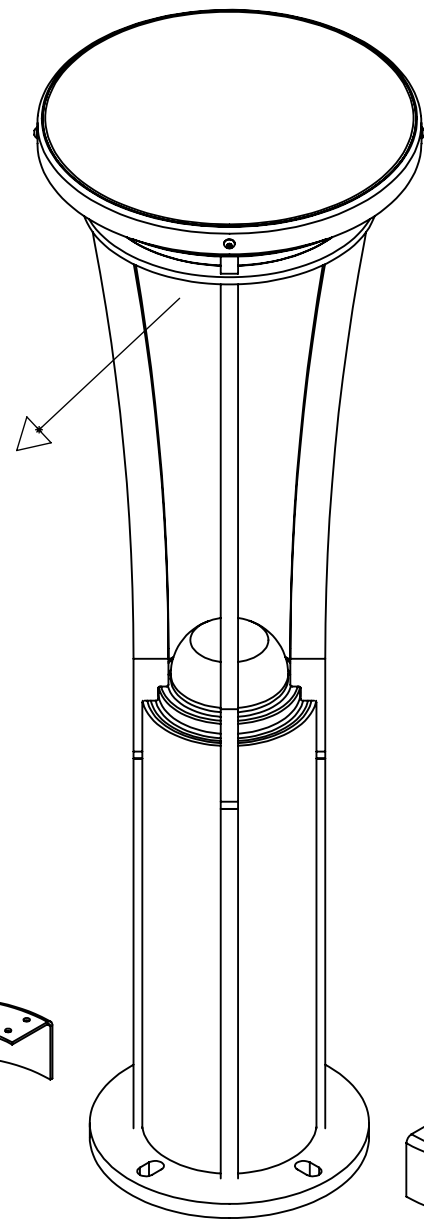
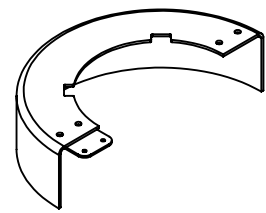
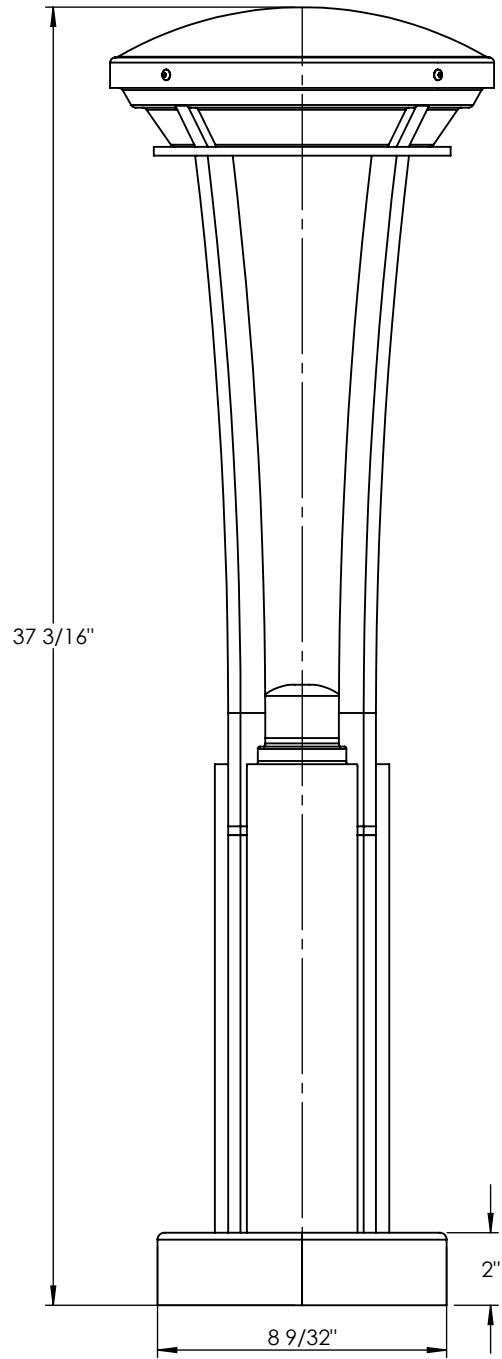

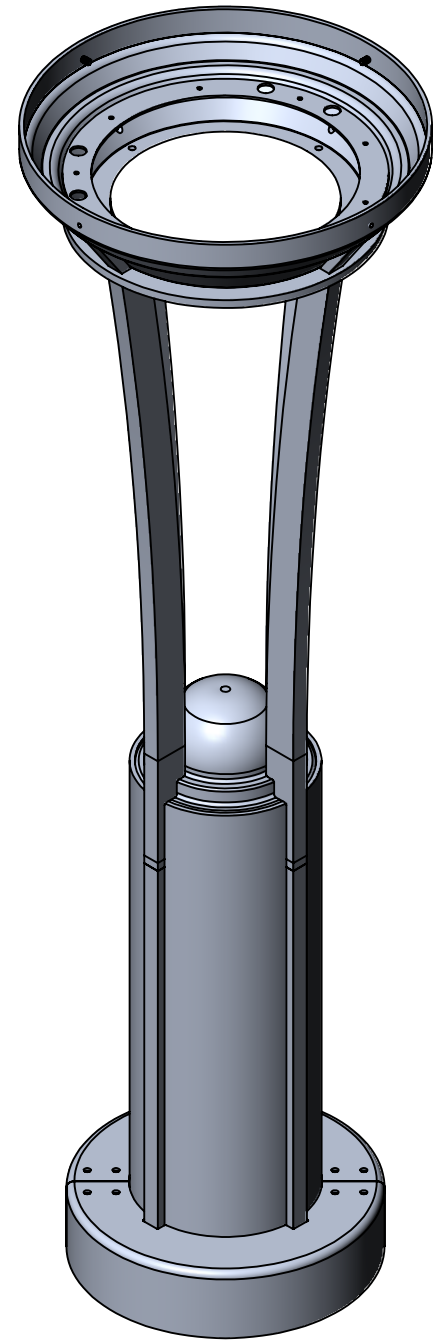
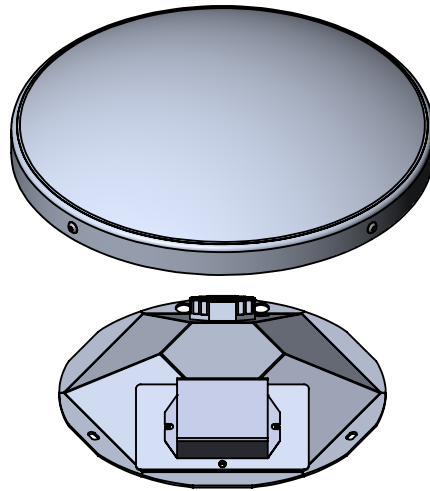
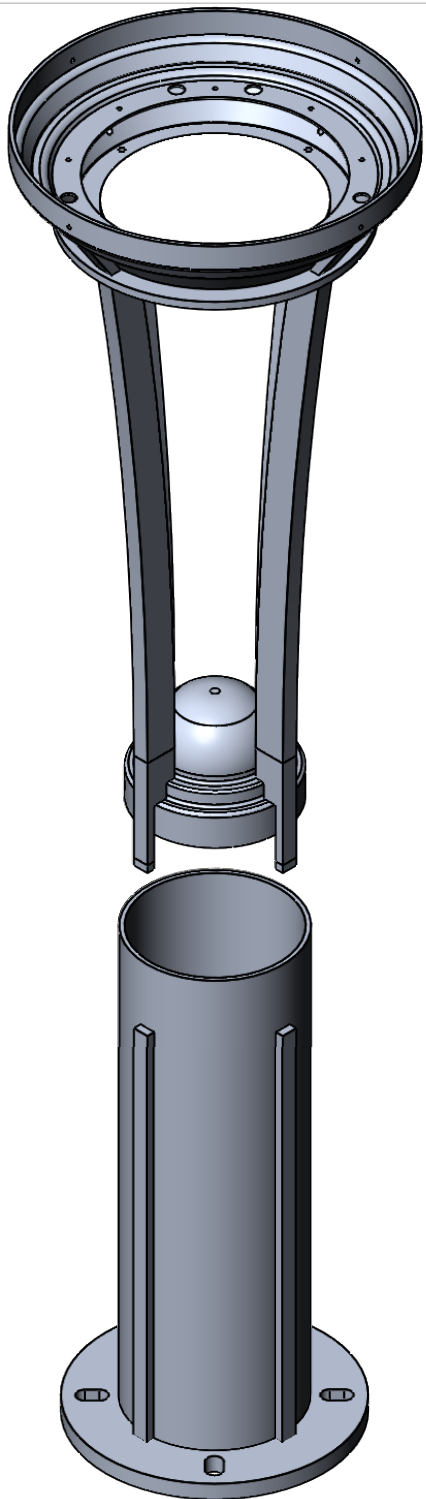

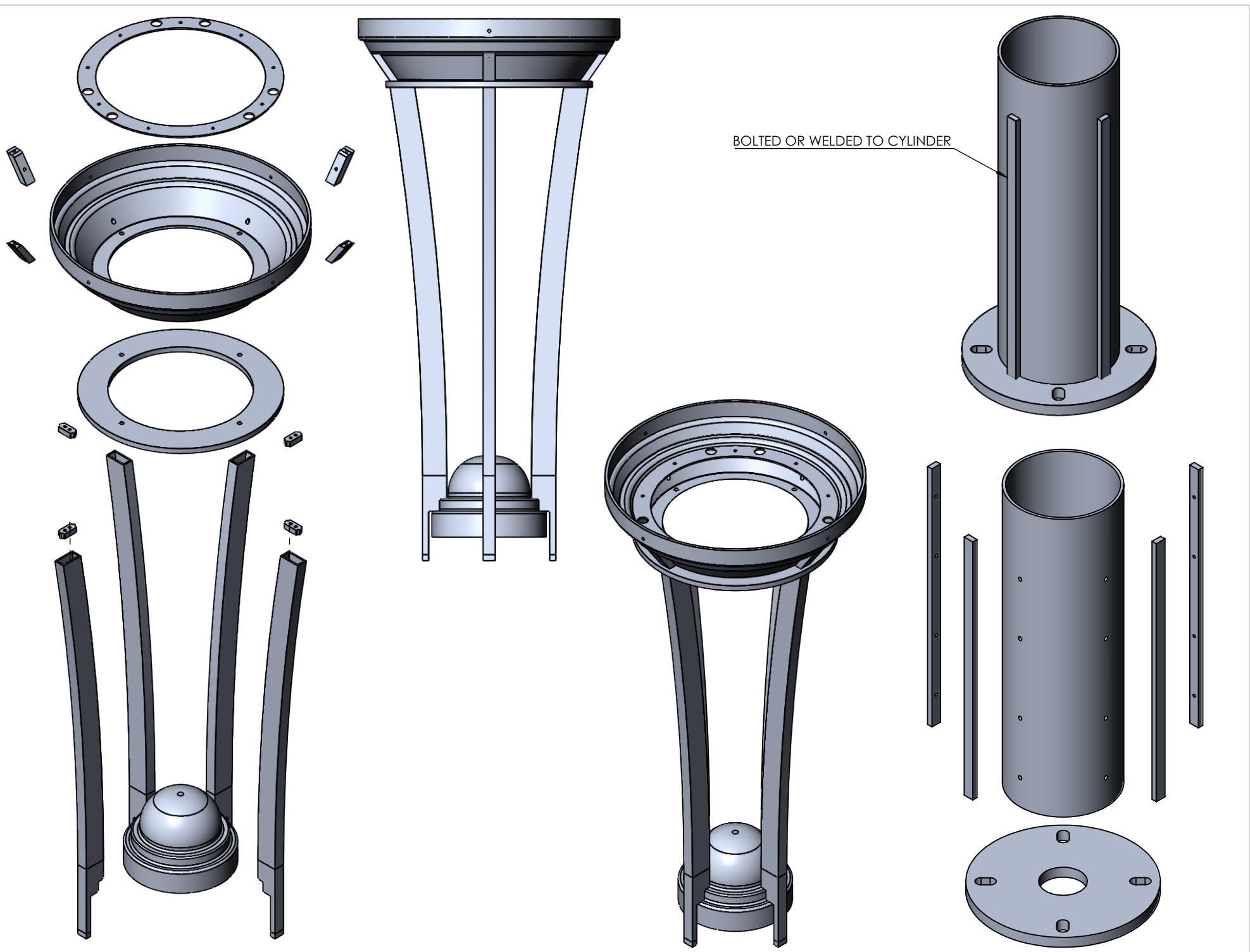

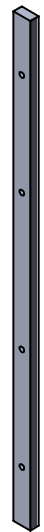
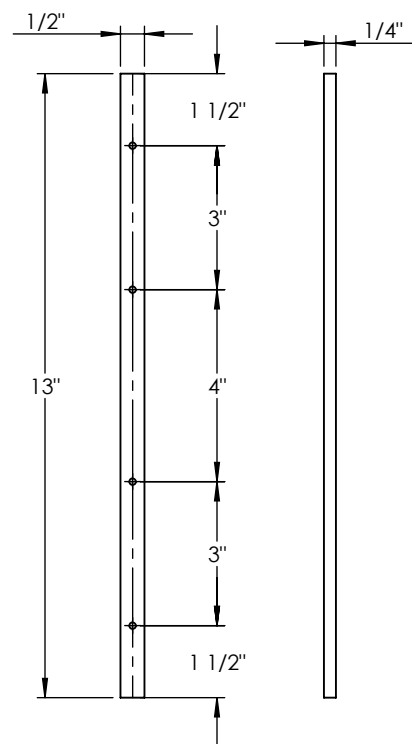
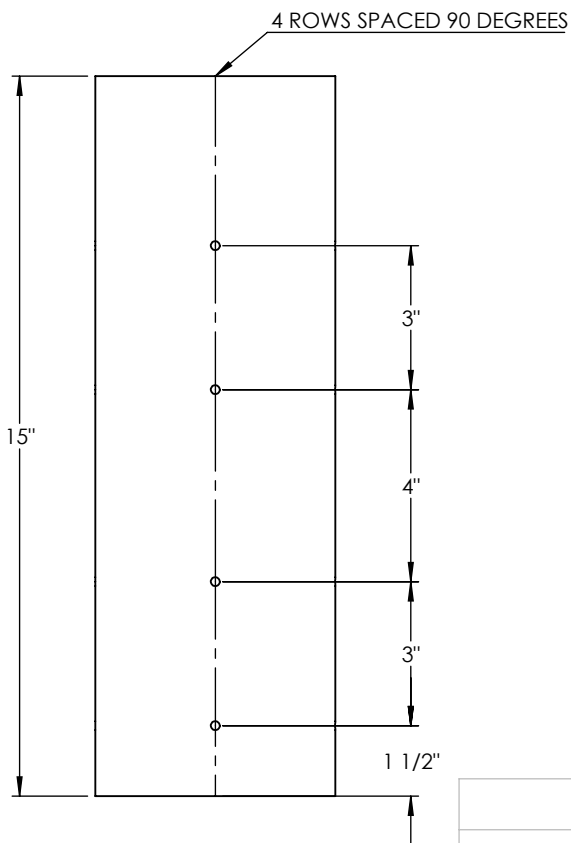
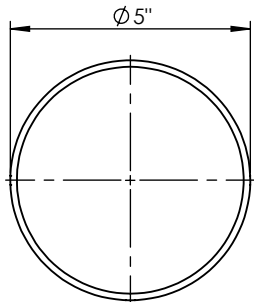

PROPRIETARY AND CONFIDENTIAL
 THE INFORMATION CONTAINED IN THIS DRAWING IS THE SOLE PROPERTY OF <INSERT COMPANY NAME HERE>. ANY REPRODUCTION IN PART OR AS A WHOLE WITHOUT THE WRITTEN PERMISSION OF <INSERT COMPANY NAME HERE> IS PROHIBITED.

		UNLESS OTHERWISE SPECIFIED:		NAME	DATE
		DIMENSIONS ARE IN INCHES	DRAWN		
		TOLERANCES:	CHECKED		
		FRACTIONAL ±	ENG APPR.		
		ANGULAR: MACH ± BEND ±	MFG APPR.		
		TWO PLACE DECIMAL ±	Q.A.		
		THREE PLACE DECIMAL ±	COMMENTS:		
		INTERPRET GEOMETRIC TOLERANCING PER:			
		MATERIAL			
		FINISH			
NEXT ASSY	USED ON				
APPLICATION		DO NOT SCALE DRAWING			

5" ALUMINUM CYLINDER		
TITLE:		
LDSCP-BOL37-4LED-AB-CFA		
SIZE	DWG. NO.	REV
A		
SCALE: 1:4	WEIGHT:	SHEET 7 OF 15

5

4

3

2

1

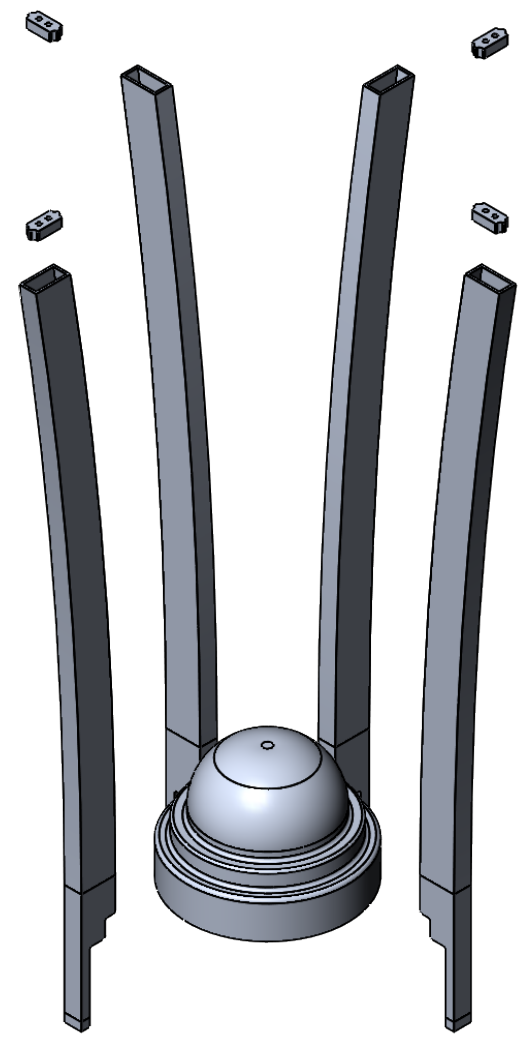
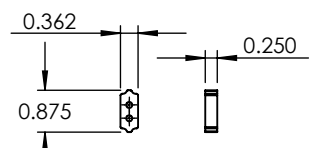
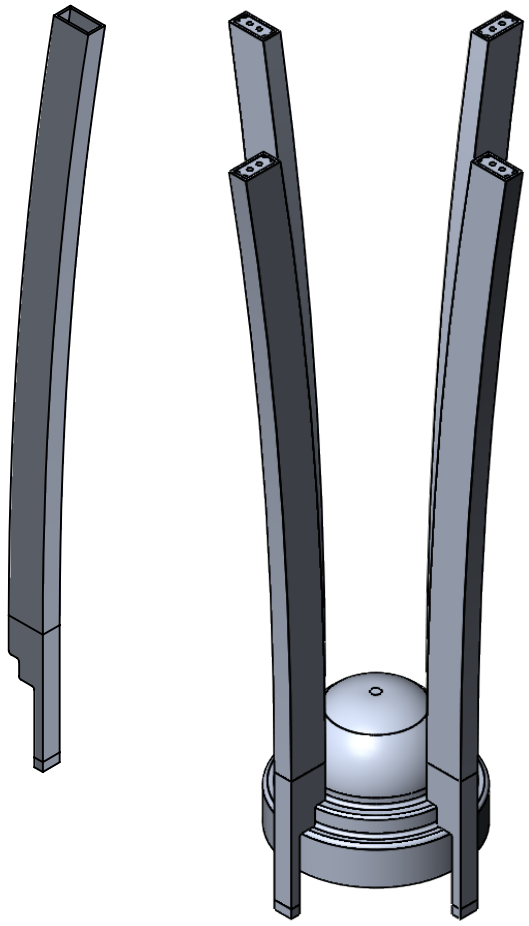
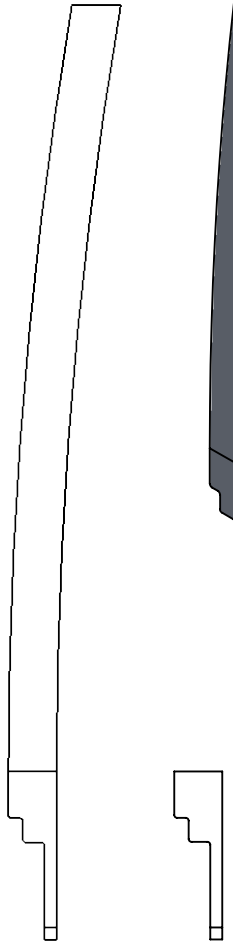
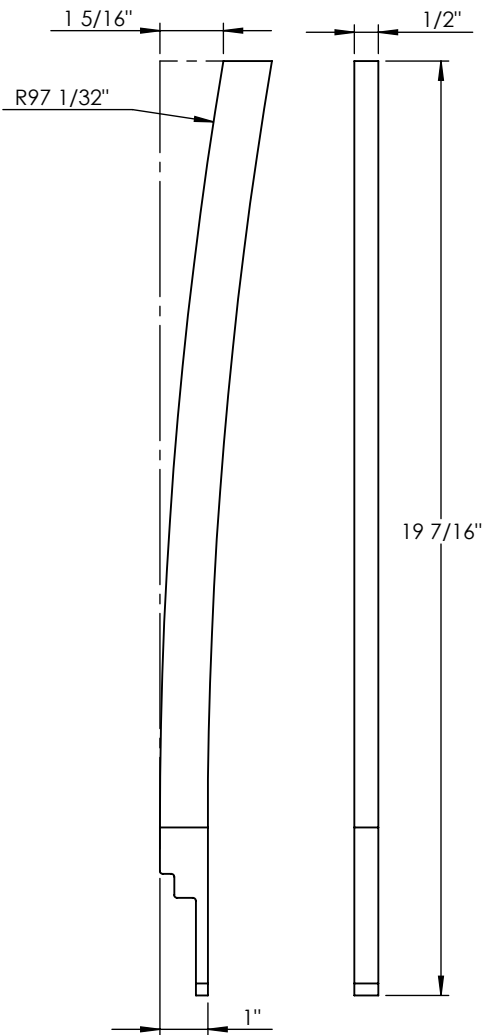

PROPRIETARY AND CONFIDENTIAL
 THE INFORMATION CONTAINED IN THIS DRAWING IS THE SOLE PROPERTY OF <INSERT COMPANY NAME HERE>. ANY REPRODUCTION IN PART OR AS A WHOLE WITHOUT THE WRITTEN PERMISSION OF <INSERT COMPANY NAME HERE> IS PROHIBITED.

NEXT ASSY	USED ON
APPLICATION	

UNLESS OTHERWISE SPECIFIED:
DIMENSIONS ARE IN INCHES
TOLERANCES:
FRACTIONAL ±
ANGULAR: MACH ± BEND ±
TWO PLACE DECIMAL ±
THREE PLACE DECIMAL ±
INTERPRET GEOMETRIC TOLERANCING PER:
MATERIAL
FINISH
DO NOT SCALE DRAWING

NAME	DATE
DRAWN	
CHECKED	
ENG APPR.	
MFG APPR.	
Q.A.	
COMMENTS:	

ALUMINUM 1"X1/2" TUBE		
TITLE:		
LDSCP-BOL37-4LED-AB-CFA		
SIZE	DWG. NO.	REV
A		
SCALE: 1:4	WEIGHT:	SHEET 8 OF 15

5

4

3

2

1

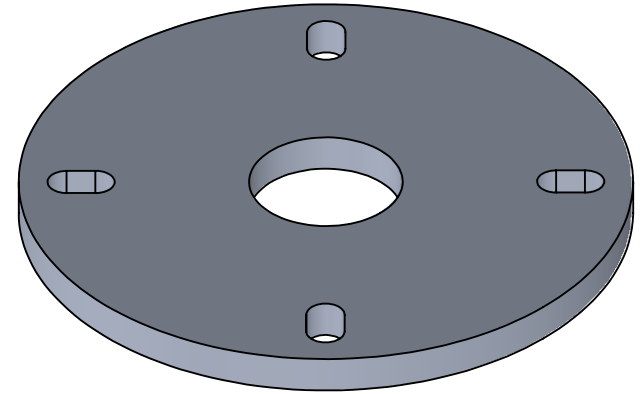
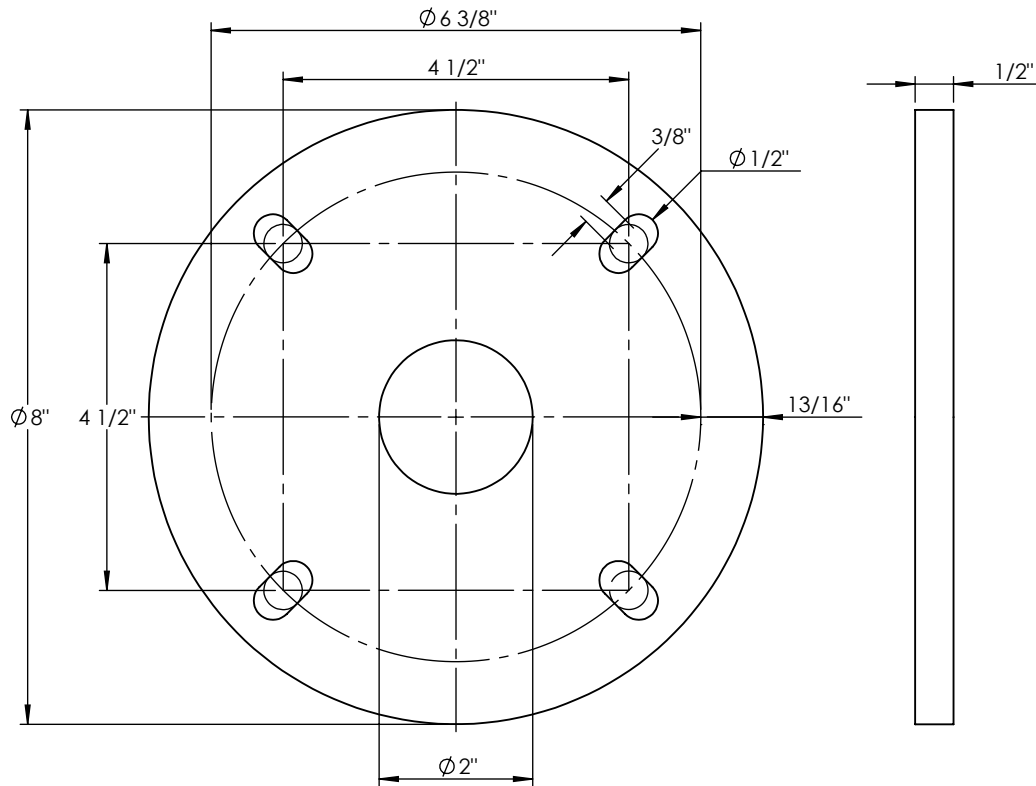

PROPRIETARY AND CONFIDENTIAL
 THE INFORMATION CONTAINED IN THIS DRAWING IS THE SOLE PROPERTY OF <INSERT COMPANY NAME HERE>. ANY REPRODUCTION IN PART OR AS A WHOLE WITHOUT THE WRITTEN PERMISSION OF <INSERT COMPANY NAME HERE> IS PROHIBITED.

		UNLESS OTHERWISE SPECIFIED:		NAME	DATE
		DIMENSIONS ARE IN INCHES	DRAWN		
		TOLERANCES:	CHECKED		
		FRACTIONAL ±	ENG APPR.		
		ANGULAR: MACH ± BEND ±	MFG APPR.		
		TWO PLACE DECIMAL ±	Q.A.		
		THREE PLACE DECIMAL ±	COMMENTS:		
		INTERPRET GEOMETRIC TOLERANCING PER:			
		MATERIAL			
NEXT ASSY	USED ON	FINISH			
APPLICATION		DO NOT SCALE DRAWING			

ALUMINUM 0.500" PLATE		
TITLE:		
LDSCP-BOL37-4LED-AB-CFA		
SIZE	DWG. NO.	REV
A		
SCALE: 1:2.5		WEIGHT:
		SHEET 9 OF 15

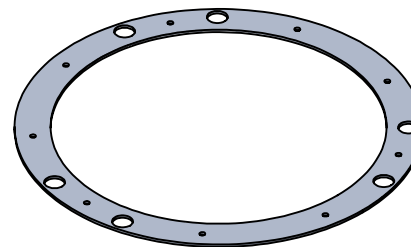
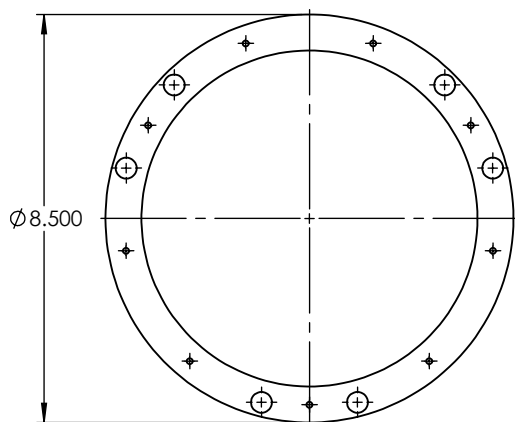
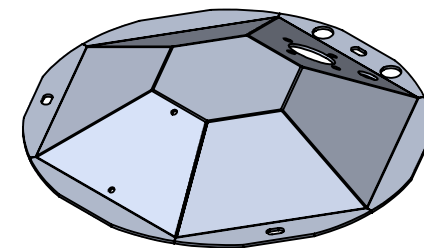
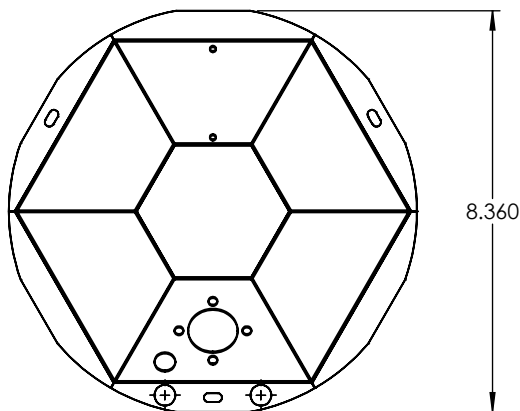
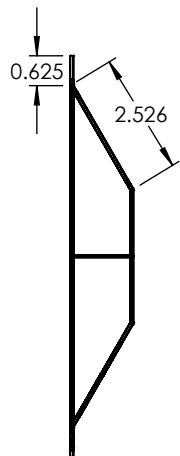
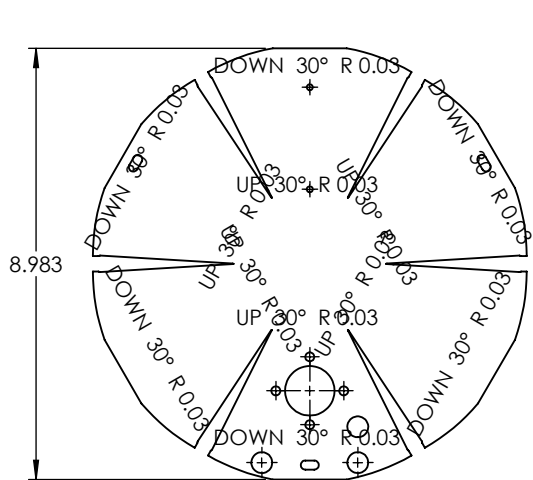

PROPRIETARY AND CONFIDENTIAL
 THE INFORMATION CONTAINED IN THIS DRAWING IS THE SOLE PROPERTY OF <INSERT COMPANY NAME HERE>. ANY REPRODUCTION IN PART OR AS A WHOLE WITHOUT THE WRITTEN PERMISSION OF <INSERT COMPANY NAME HERE> IS PROHIBITED.

		UNLESS OTHERWISE SPECIFIED:		NAME	DATE
		DIMENSIONS ARE IN INCHES	DRAWN		
		TOLERANCES:	CHECKED		
		FRACTIONAL ±	ENG APPR.		
		ANGULAR: MACH ± BEND ±	MFG APPR.		
		TWO PLACE DECIMAL ±	Q.A.		
		THREE PLACE DECIMAL ±	COMMENTS:		
		INTERPRET GEOMETRIC TOLERANCING PER:			
		MATERIAL			
		FINISH			
NEXT ASSY	USED ON				
APPLICATION		DO NOT SCALE DRAWING			

ALUMINUM 0.0635"		
TITLE:		
LDSCP-BOL37-4LED-AB-CFA		
SIZE	DWG. NO.	REV
A		
SCALE: 1:4	WEIGHT:	SHEET 10 OF 15

ITEM NO.	PART NUMBER	DESCRIPTION	QTY.
1	LDSCP-BOL37-4LED-AB-CFA-ROUND COVER	SPUN ALUMINUM 0.080"	1

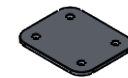
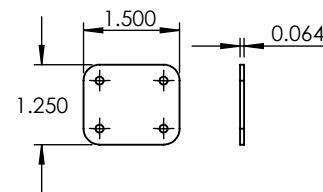
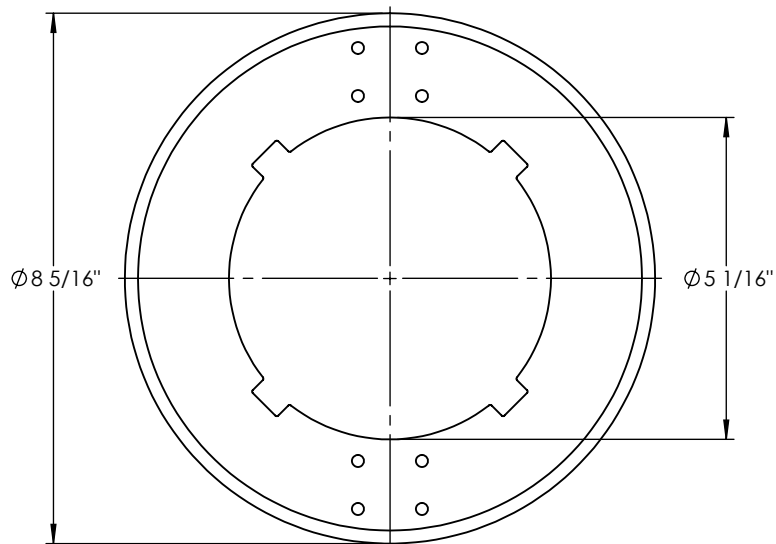
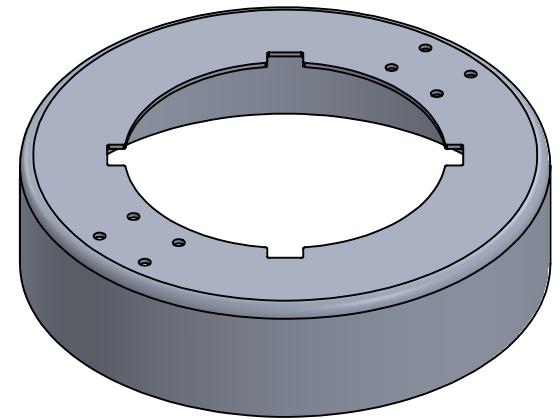
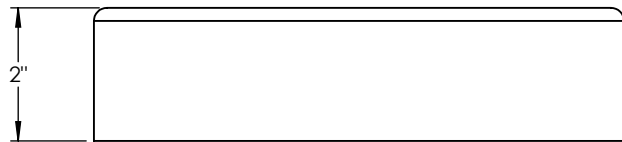

CUSTOM FLAT BLANK REQUIRED FROM FABRICATION DEPT.

PROPRIETARY AND CONFIDENTIAL
 THE INFORMATION CONTAINED IN THIS DRAWING IS THE SOLE PROPERTY OF <INSERT COMPANY NAME HERE>. ANY REPRODUCTION IN PART OR AS A WHOLE WITHOUT THE WRITTEN PERMISSION OF <INSERT COMPANY NAME HERE> IS PROHIBITED.

		UNLESS OTHERWISE SPECIFIED:	NAME	DATE	SPUN ALUMINUM 0.080"	
		DIMENSIONS ARE IN INCHES	DRAWN		TITLE:	
		TOLERANCES:	CHECKED		LDSCP-BOL37-4LED-AB-CFA	
		FRACTIONAL ±	ENG APPR.		SIZE	DWG. NO.
		ANGULAR: MACH ± BEND ±	MFG APPR.		A	REV
		TWO PLACE DECIMAL ±	Q.A.		SCALE: 1:3	WEIGHT:
		THREE PLACE DECIMAL ±	COMMENTS:			SHEET 11 OF 15
NEXT ASSY	USED ON	INTERPRET GEOMETRIC TOLERANCING PER:				
APPLICATION		MATERIAL				
		FINISH				
		DO NOT SCALE DRAWING				

ITEM NO.	PART NUMBER	DESCRIPTION	QTY.
1	LDSCP-BOL37-4LED-AB-CFA-BOTTOM SPINNING	SPUN ALUMINUM 0.125"	1

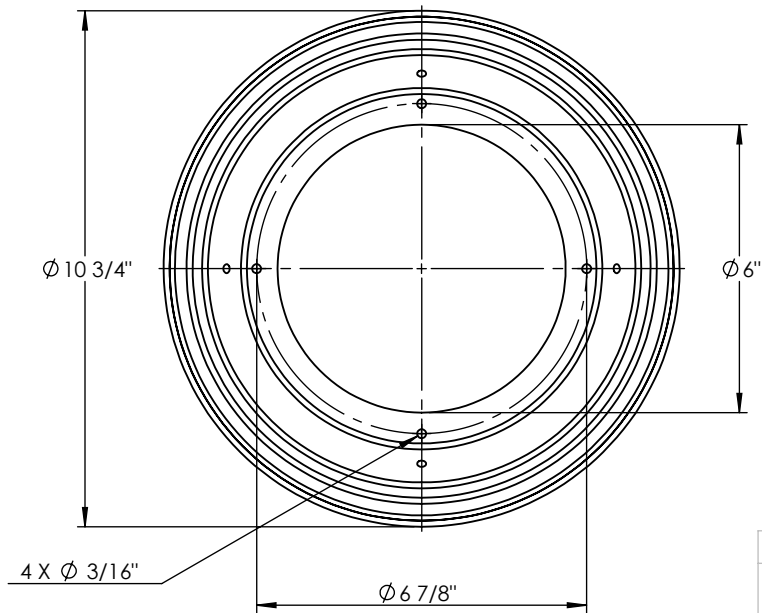
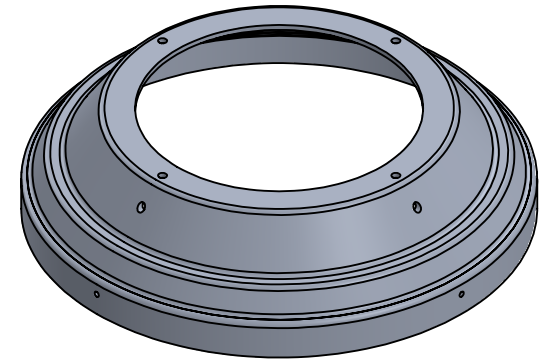
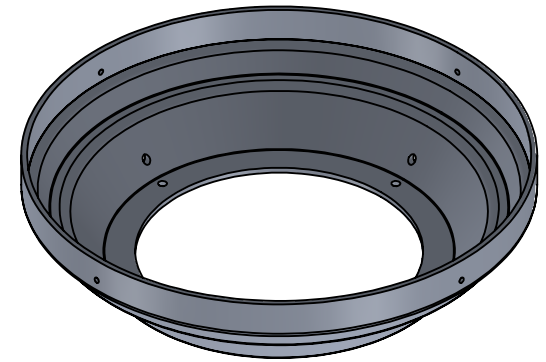
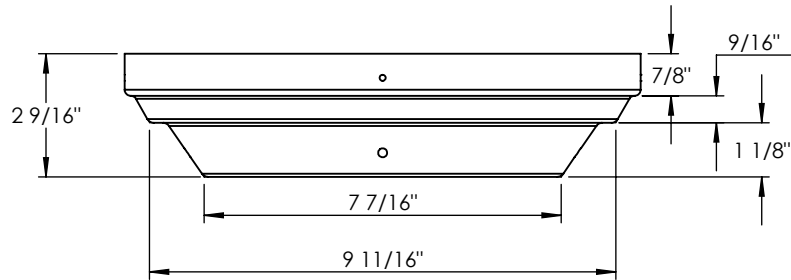

UNLESS OTHERWISE SPECIFIED:		NAME	DATE	SPUN ALUMINUM 0.125"	
DIMENSIONS ARE IN INCHES		DRAWN		TITLE:	
TOLERANCES:		CHECKED		LDSCP-BOL37-4LED-AB-CFA	
FRACTIONAL ±		ENG APPR.		SIZE	DWG. NO.
ANGULAR: MACH ± BEND ±		MFG APPR.		A	REV
TWO PLACE DECIMAL ±		Q.A.		SCALE: 1:4	WEIGHT:
THREE PLACE DECIMAL ±		COMMENTS:			SHEET 12 OF 15
INTERPRET GEOMETRIC TOLERANCING PER:					
MATERIAL					
FINISH					
APPLICATION					
DO NOT SCALE DRAWING					

PROPRIETARY AND CONFIDENTIAL
 THE INFORMATION CONTAINED IN THIS DRAWING IS THE SOLE PROPERTY OF <INSERT COMPANY NAME HERE>. ANY REPRODUCTION IN PART OR AS A WHOLE WITHOUT THE WRITTEN PERMISSION OF <INSERT COMPANY NAME HERE> IS PROHIBITED.

ITEM NO.	PART NUMBER	DESCRIPTION	QTY.
1	LDSCP-BOL37-4LED-AB-CFA-TOP SPINNING	SPUN ALUMINUM 0.080"	1

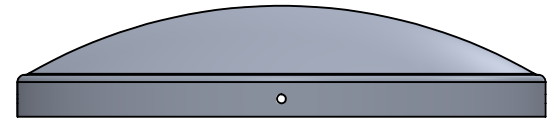
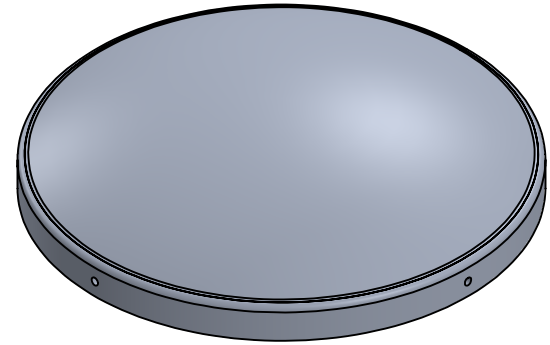
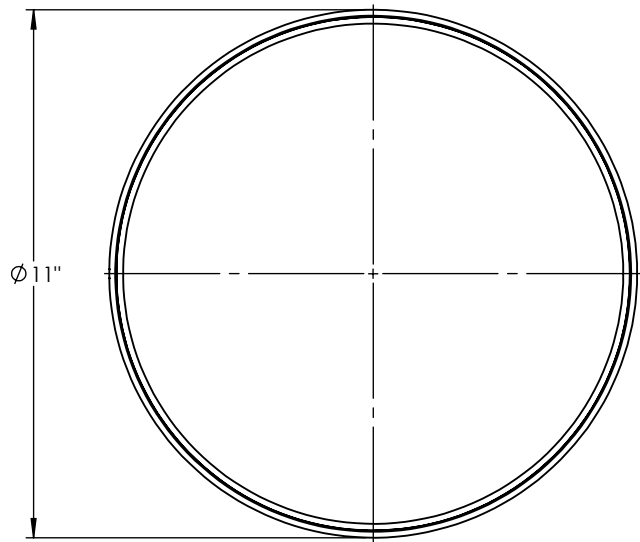
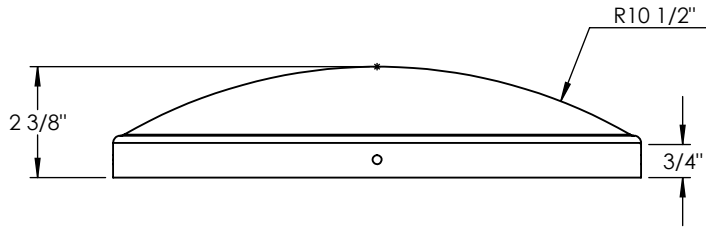

UNLESS OTHERWISE SPECIFIED:		NAME	DATE	SPUN ALUMINUM 0.125"		
DIMENSIONS ARE IN INCHES TOLERANCES: FRACTIONAL ± ANGULAR: MACH ± BEND ± TWO PLACE DECIMAL ± THREE PLACE DECIMAL ±		DRAWN				TITLE:
INTERPRET GEOMETRIC TOLERANCING PER:		CHECKED		LDSCP-BOL37-4LED-AB-CFA		
		ENG APPR.				
		MFG APPR.				
MATERIAL		Q.A.		SIZE	DWG. NO.	REV
FINISH		COMMENTS:		A		
DO NOT SCALE DRAWING				SCALE: 1:4	WEIGHT:	SHEET 13 OF 15

PROPRIETARY AND CONFIDENTIAL
THE INFORMATION CONTAINED IN THIS DRAWING IS THE SOLE PROPERTY OF <INSERT COMPANY NAME HERE>. ANY REPRODUCTION IN PART OR AS A WHOLE WITHOUT THE WRITTEN PERMISSION OF <INSERT COMPANY NAME HERE> IS PROHIBITED.

NEXT ASSY	USED ON
APPLICATION	

ITEM NO.	PART NUMBER	DESCRIPTION	QTY.
1	LDSCP-BOL37-4LED-AB-CFA-8" SPUN SPHERE	SPUN ALUMINUM 0.125"	1

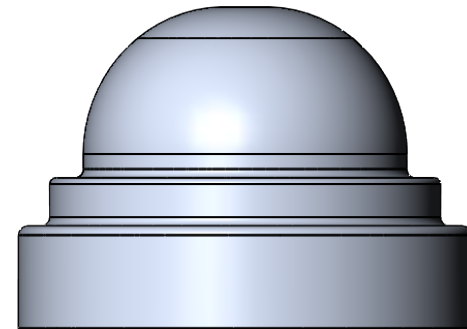
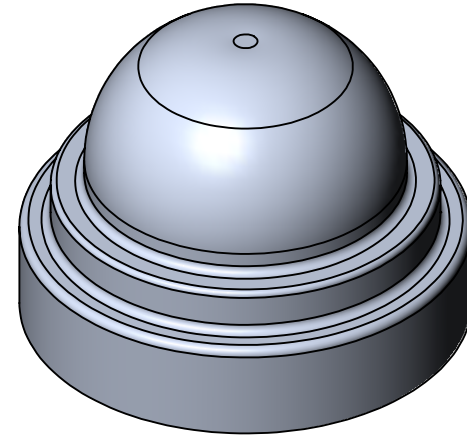
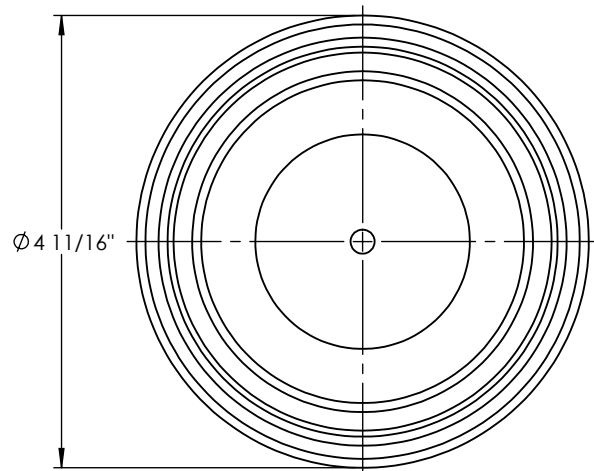
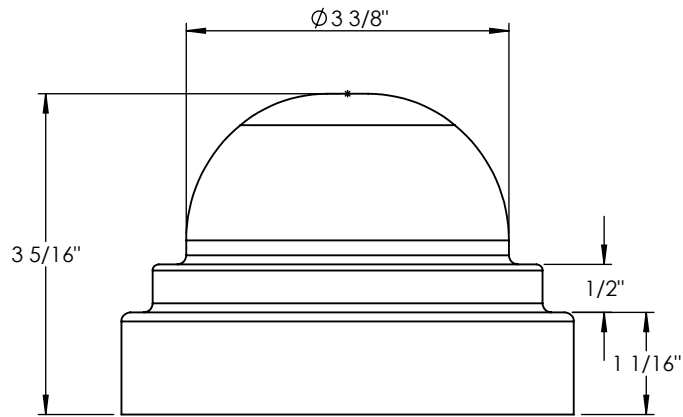

PROPRIETARY AND CONFIDENTIAL
 THE INFORMATION CONTAINED IN THIS DRAWING IS THE SOLE PROPERTY OF <INSERT COMPANY NAME HERE>. ANY REPRODUCTION IN PART OR AS A WHOLE WITHOUT THE WRITTEN PERMISSION OF <INSERT COMPANY NAME HERE> IS PROHIBITED.

		UNLESS OTHERWISE SPECIFIED:		NAME	DATE
		DIMENSIONS ARE IN INCHES TOLERANCES: FRACTIONAL ± ANGULAR: MACH ± BEND ± TWO PLACE DECIMAL ± THREE PLACE DECIMAL ±	DRAWN		
		INTERPRET GEOMETRIC TOLERANCING PER:	CHECKED		
		MATERIAL	ENG APPR.		
		FINISH	MFG APPR.		
NEXT ASSY	USED ON		Q.A.		
			COMMENTS:		
APPLICATION		DO NOT SCALE DRAWING			

SPUN ALUMINUM 0.125"		
TITLE:		
LDSCP-BOL37-4LED-AB-CFA		
SIZE	DWG. NO.	REV
A		
SCALE: 1:2	WEIGHT:	SHEET 14 OF 15

5

4

3

2

1

