

ITEM NO.	PART NUMBER	DESCRIPTION	QTY.	CUT
1	CLG-DM19"-36W-GW-A-DIM-41K-TOP SPUN BACKPLATE	SPUN 22 GAUGE	1	
2	CLG-DM19"-36W-GW-A-DIM-41K-TOP SPUN FIREPLATE	SPUN 22 GAUGE	1	
3	CLG-DM19"-36W-GW-A-DIM-41K-SPUN TOP CAP	SPUN 22 GAUGE	1	
4	CLG-DM19"-36W-GW-A-DIM-41K-SPUN BOTTOM CAP	SPUN 22 GAUGE	1	
5	CLG-DM19"-36W-GW-A-DIM-41K-STRAP PATTERN	22 GAUGE	1	
6	CLG-DM19"-36W-GW-A-DIM-41K-ACRYLIC	ACRYLIC	1	
7	KTLD-25-UV-700-VDIM-LA1	DRIVER	2	
8	AltalLED_PN1011_RevB	LED	4	
9	AltalLED_PN105B-11-SS	LED	4	

UNLESS OTHERWISE SPECIFIED:

DIMENSIONS ARE IN INCHES
 TOLERANCES:
 FRACTIONAL ± .003
 ANGULAR: MACH ± .01 BEND ±
 TWO PLACE DECIMAL ±
 THREE PLACE DECIMAL ±.001

INTERPRET GEOMETRIC
 TOLERANCING PER:

MATERIAL

FINISH

DRAWN

CHECKED

ENG APPR.

MFG APPR.

Q.A.

COMMENTS:

NAME

DATE

TITLE:

CLG-19"-36W-GW-A-DIM-41K

SIZE DWG. NO.

REV

A TICKET 25444

SCALE: 1:8

WEIGHT:

SHEET 1 OF 6

ALL BEND RADIUS .030"

APPLICATION

DO NOT SCALE DRAWING



EVERGREEN LIGHTING

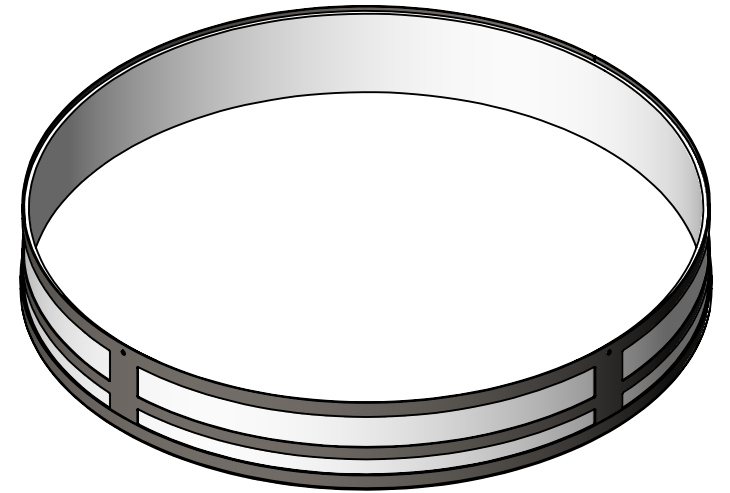
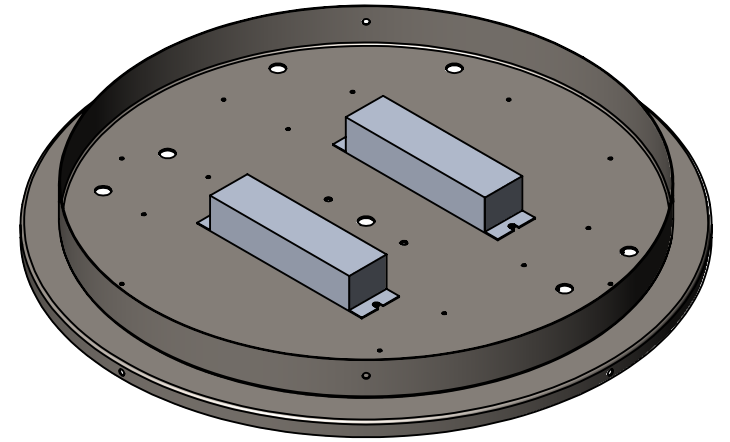
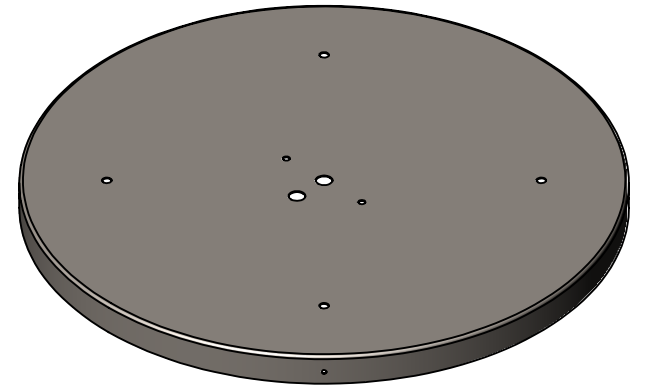
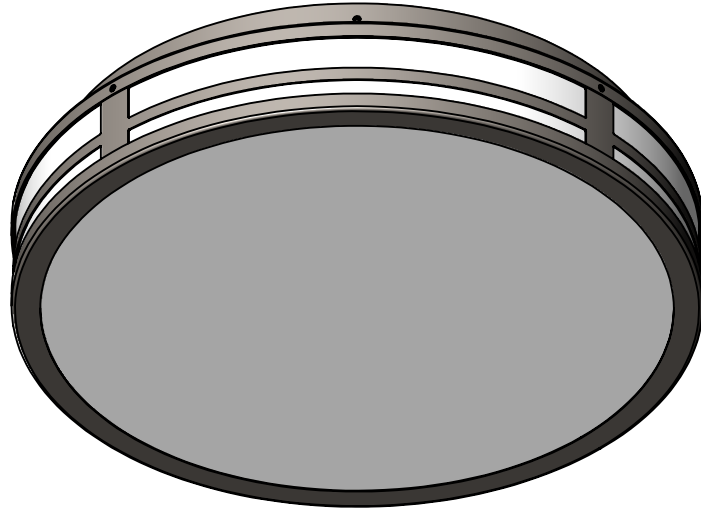
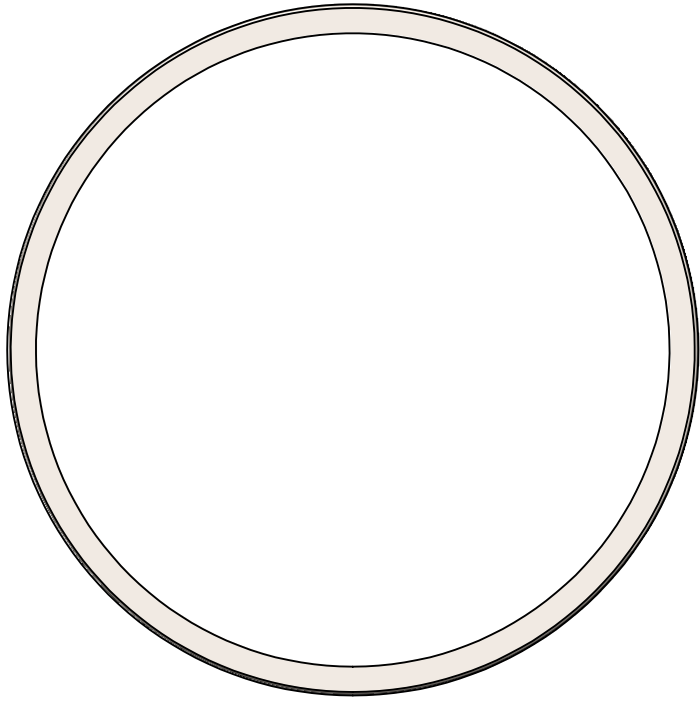
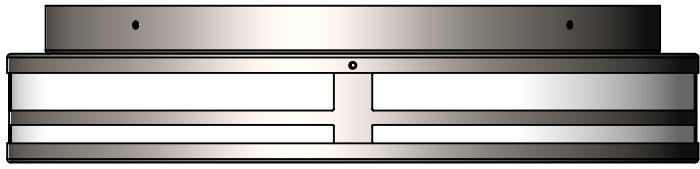

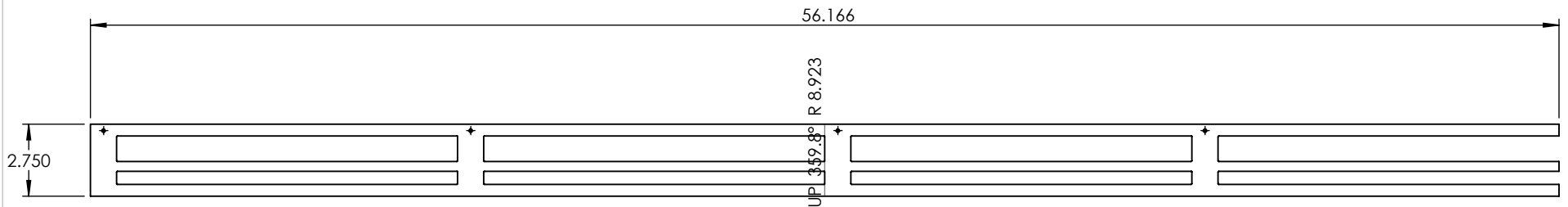
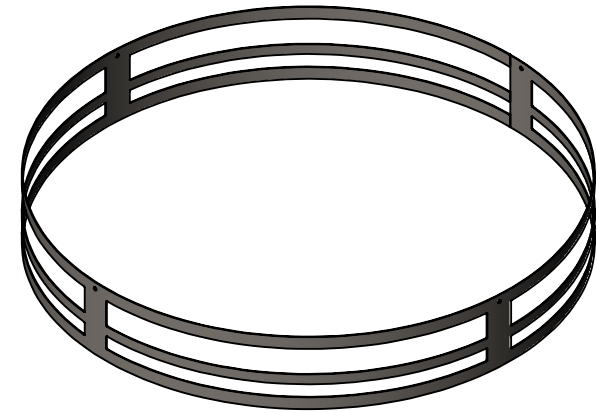
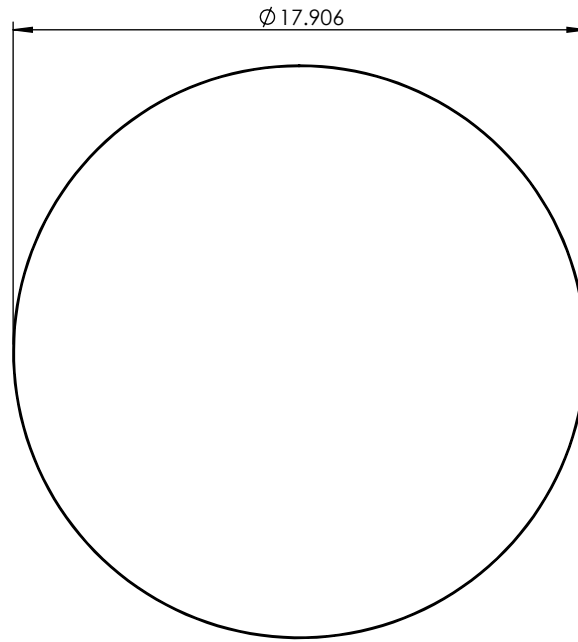

PROPRIETARY AND CONFIDENTIAL
 THE INFORMATION CONTAINED IN THIS DRAWING IS THE SOLE PROPERTY OF <INSERT COMPANY NAME HERE>. ANY REPRODUCTION IN PART OR AS A WHOLE WITHOUT THE WRITTEN PERMISSION OF <INSERT COMPANY NAME HERE> IS PROHIBITED.

		UNLESS OTHERWISE SPECIFIED:		NAME	DATE	22 GAUGE		
		DIMENSIONS ARE IN INCHES TOLERANCES: FRACTIONAL ± ANGULAR: MACH ± BEND ± TWO PLACE DECIMAL ± THREE PLACE DECIMAL ±	DRAWN					TITLE: CLG-19"-36W-GW-A-DIM-41K
		INTERPRET GEOMETRIC TOLERANCING PER:	CHECKED			A	DWG. NO.	
		MATERIAL	ENG APPR.					SCALE: 1:6 WEIGHT:
		FINISH	MFG APPR.			NEXT ASSY USED ON		
		APPLICATION	Q.A.			DO NOT SCALE DRAWING		
			COMMENTS:					

ITEM NO.	PART NUMBER	DESCRIPTION	QTY.
1	CLG-DM19"-36W-GW-A-DIM-41K-SPUN TOP CAP	SPUN 22 GAUGE	1

ITEM NO.	PART NUMBER	DESCRIPTION	QTY.
1	CLG-DM19"-36W-GW-A-DIM-41K-SPUN BOTTOM CAP	SPUN 22 GAUGE	1

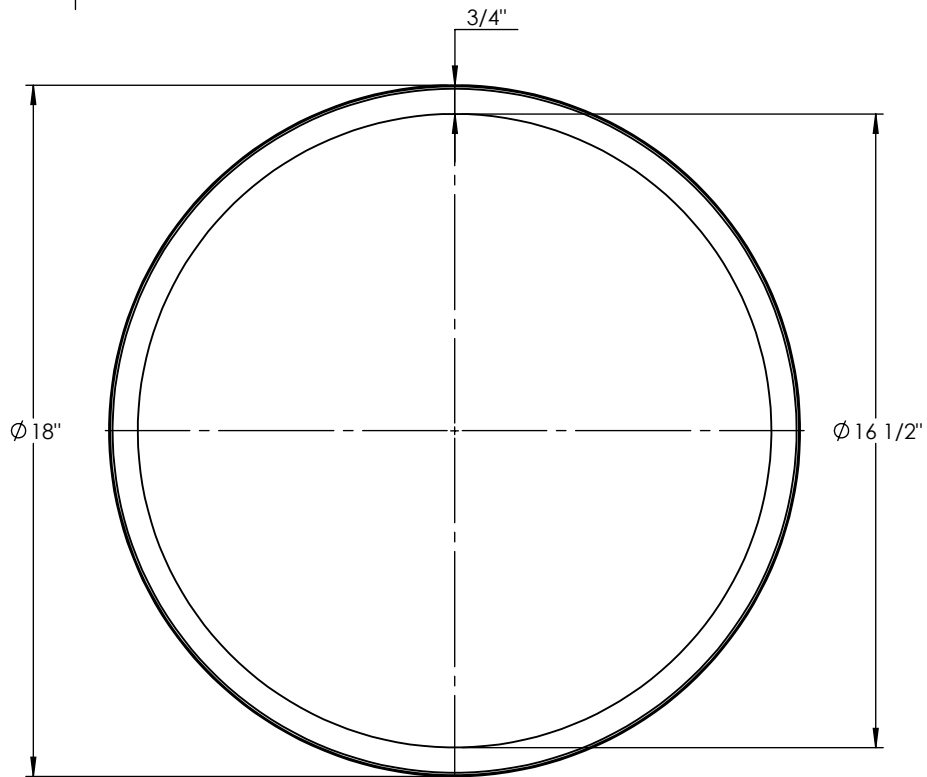
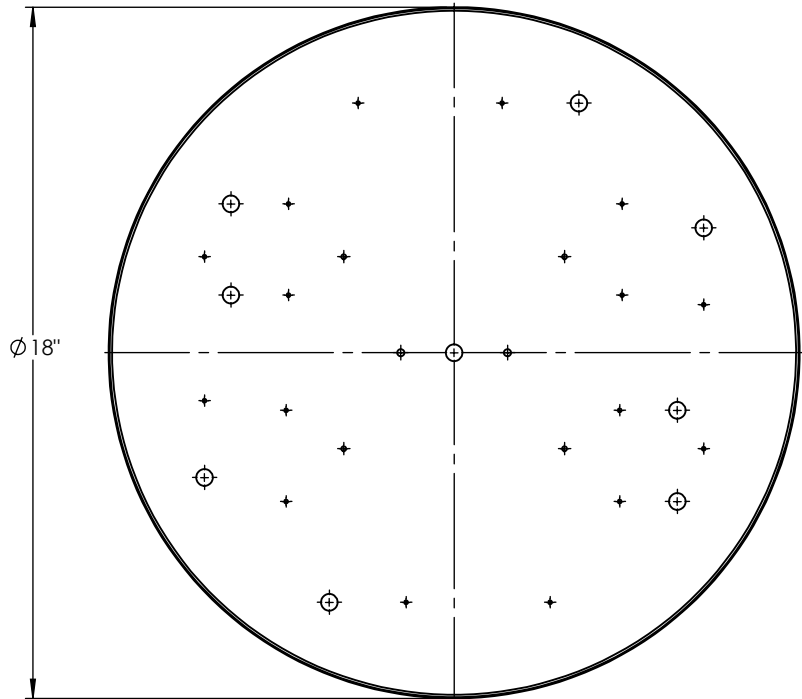
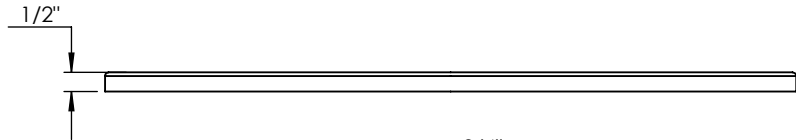
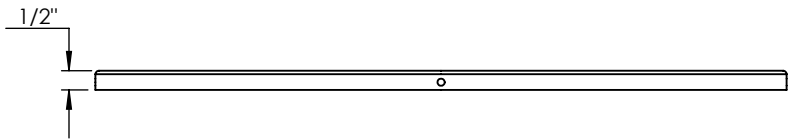

PROPRIETARY AND CONFIDENTIAL
 THE INFORMATION CONTAINED IN THIS DRAWING IS THE SOLE PROPERTY OF <INSERT COMPANY NAME HERE>. ANY REPRODUCTION IN PART OR AS A WHOLE WITHOUT THE WRITTEN PERMISSION OF <INSERT COMPANY NAME HERE> IS PROHIBITED.

UNLESS OTHERWISE SPECIFIED:		NAME	DATE
DIMENSIONS ARE IN INCHES		DRAWN	
TOLERANCES:		CHECKED	
FRACTIONAL ±		ENG APPR.	
ANGULAR: MACH ± BEND ±		MFG APPR.	
TWO PLACE DECIMAL ±		Q.A.	
THREE PLACE DECIMAL ±		COMMENTS:	
INTERPRET GEOMETRIC TOLERANCING PER:			
MATERIAL			
FINISH			
NEXT ASSY	USED ON		
APPLICATION			
DO NOT SCALE DRAWING			

SPUN 22 GAUGE

TITLE:
 CLG-19"-36W-GW-A-DIM-41K

SIZE A	DWG. NO.	REV
SCALE: 1:5	WEIGHT:	SHEET 4 OF 6

ITEM NO.	PART NUMBER	DESCRIPTION	QTY.
1	CLG-DM19"-36W-GW-A-DIM-41K-TOP SPUN BACKPLATE	SPUN 22 GAUGE	1

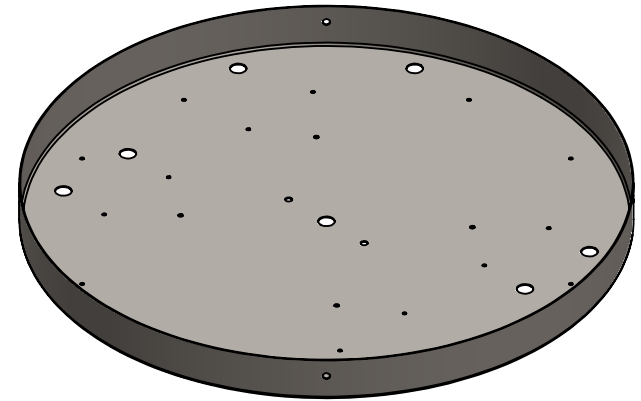
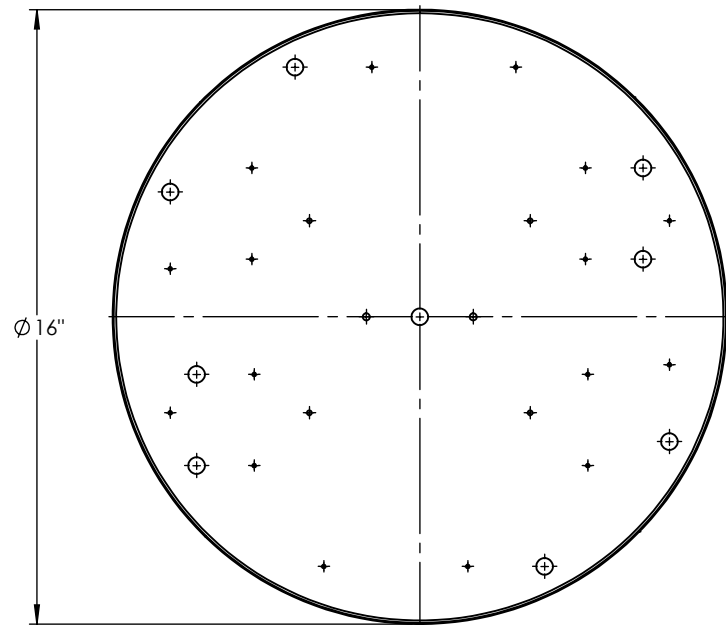
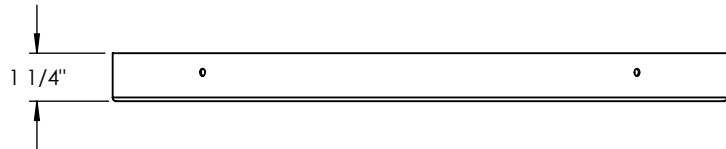

PROPRIETARY AND CONFIDENTIAL
 THE INFORMATION CONTAINED IN THIS DRAWING IS THE SOLE PROPERTY OF <INSERT COMPANY NAME HERE>. ANY REPRODUCTION IN PART OR AS A WHOLE WITHOUT THE WRITTEN PERMISSION OF <INSERT COMPANY NAME HERE> IS PROHIBITED.

		UNLESS OTHERWISE SPECIFIED:	NAME	DATE	TITLE: SPUN 22 GAUGE	
		DIMENSIONS ARE IN INCHES TOLERANCES: FRACTIONAL ± ANGULAR: MACH ± BEND ± TWO PLACE DECIMAL ± THREE PLACE DECIMAL ±	DRAWN			
		INTERPRET GEOMETRIC TOLERANCING PER:	CHECKED		CLG-19"-36W-GW-A-DIM-41K	
		MATERIAL	ENG APPR.			
		FINISH	MFG APPR.		SIZE DWG. NO. REV	
			Q.A.			
NEXT ASSY	USED ON		COMMENTS:		SCALE: 1:5 WEIGHT: SHEET 5 OF 6	
APPLICATION		DO NOT SCALE DRAWING				

5

4

3

2

1

ITEM NO.	PART NUMBER	DESCRIPTION	QTY.
1	CLG-DM19"-36W-GW-A-DIM-41K-TOP SPUN FIREPLATE	SPUN 22 GAUGE	1

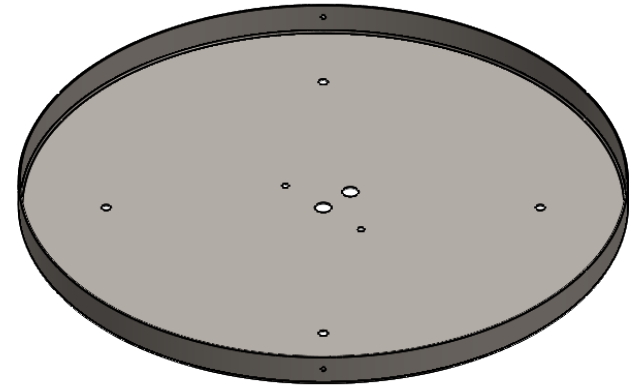
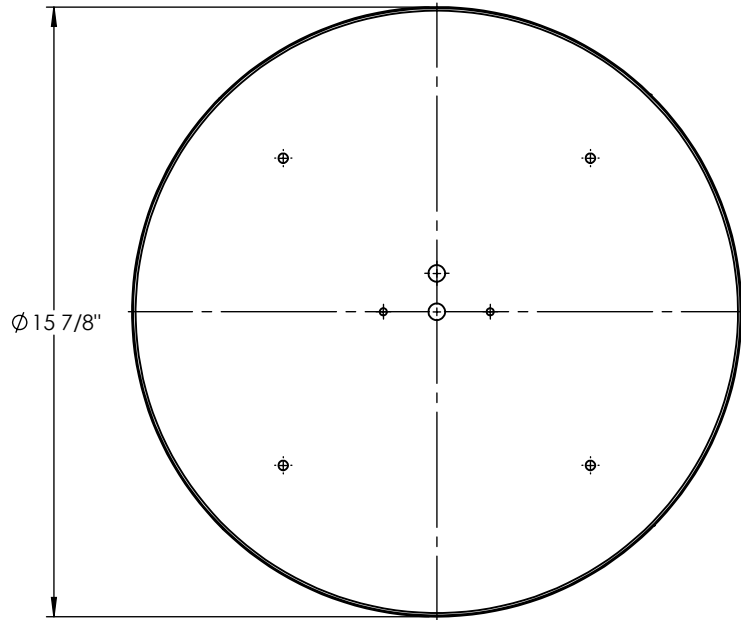
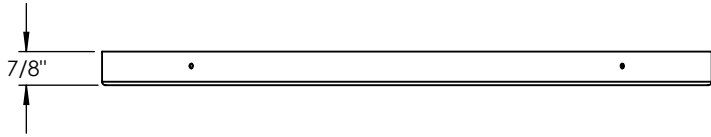

PROPRIETARY AND CONFIDENTIAL
 THE INFORMATION CONTAINED IN THIS DRAWING IS THE SOLE PROPERTY OF <INSERT COMPANY NAME HERE>. ANY REPRODUCTION IN PART OR AS A WHOLE WITHOUT THE WRITTEN PERMISSION OF <INSERT COMPANY NAME HERE> IS PROHIBITED.

		UNLESS OTHERWISE SPECIFIED:	NAME	DATE
		DIMENSIONS ARE IN INCHES TOLERANCES: FRACTIONAL ± ANGULAR: MACH ± BEND ± TWO PLACE DECIMAL ± THREE PLACE DECIMAL ±	DRAWN	
		INTERPRET GEOMETRIC TOLERANCING PER:	CHECKED	
		MATERIAL	ENG APPR.	
		FINISH	MFG APPR.	
			Q.A.	
			COMMENTS:	
NEXT ASSY	USED ON			
APPLICATION		DO NOT SCALE DRAWING		

TITLE:		
SPUN 22 GAUGE		
CLG-19"-36W-GW-A-DIM-41K		
SIZE	DWG. NO.	REV
A		
SCALE: 1:5	WEIGHT:	SHEET 6 OF 6

5

4

3

2

1