

ITEM NO.	PART NUMBER	DESCRIPTION	QTY.	CUT
1	VEN-30-L36-120V-2-WH9-TP-30K-12" SPUN SPHERE	SPUN ALUMINUM 0.080"	1	
2	VEN-30-L36-120V-2-WH9-TP-30K-12" CYLINDER	8" DIAMETER CYLINDER	1	
3	VEN-30-L36-120V-2-WH9-TP-30K-ANCHOR PLATE	ALUMINUM 0.500" PLATE	1	
4	VEN-30-L36-120V-2-WH9-TP-30K-SQUARE TUBE	1" SQUARE ALUMINUM TUBE	1	
5	VEN-30-L36-120V-2-WH9-TP-30K-TUBE FLANGE	ALUMINUM 0.500" PLATE	2	
6	VEN-30-L36-120V-2-WH9-TP-30K-DRIVER BRACKET	ALUMINUM 0.0635"	1	
7	VEN-30-L36-120V-2-WH9-TP-30K-SPUN CYLINDER COVER	SPUN ALUMINUM 0.080"	1	
8	VEN-30-L36-120V-2-WH9-TP-30K-REFLECTOR LOUVER	SPUN ALUMINUM 0.0635"	5	
9	VEN-30-L36-120V-2-WH9-TP-30K-8" LENS	ACRYLIC	1	
10	VEN-30-L36-120V-2-WH9-TP-30K-LOUVER THREADED STUD	1/4" THREADED ROD	4	
12	VEN-30-L36-120V-2-WH9-TP-30K-12" SPHERE PLATE	ALUMINUM 0.125" PLATE	1	
13	VEN-30-L36-120V-2-WH9-TP-30K-8" SPUN LENS CAP	SPUN ALUMINUM 0.080"	2	
14	VEN-30-L36-120V-2-WH9-TP-30K-0.500" REFLECTOR SPACER 1"	3/8" ALUMINUM CYLINDER	12	
15	VEN-30-L36-120V-2-WH9-TP-30K-0.500" REFLECTOR SPACER 1"	3/8" ALUMINUM CYLINDER	4	
16	VEN-30-L36-120V-2-WH9-TP-30K-TUBE BRACKET	ALUMINUM 0.0635"	1	
17	VEN-30-L36-120V-2-WH9-TP-30K-LOUVER PLATE BOTTOM	ALUMINUM 0.125" PLATE	1	
18	VEN-30-L36-120V-2-WH9-TP-30K-0.250" THREADED STUD	1/4" THREADED ROD	4	
19	VEN-30-L36-120V-2-WH9-TP-30K-ANCHOR PLATE TAB	ALUMINUM 0.500" PLATE	4	
20	Espen VEL19070MVH-1	DRIVER	2	
21	Alttailed PN1012 RevD	LED	8	

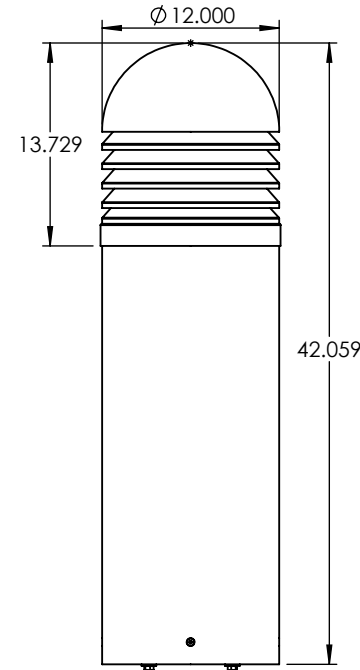
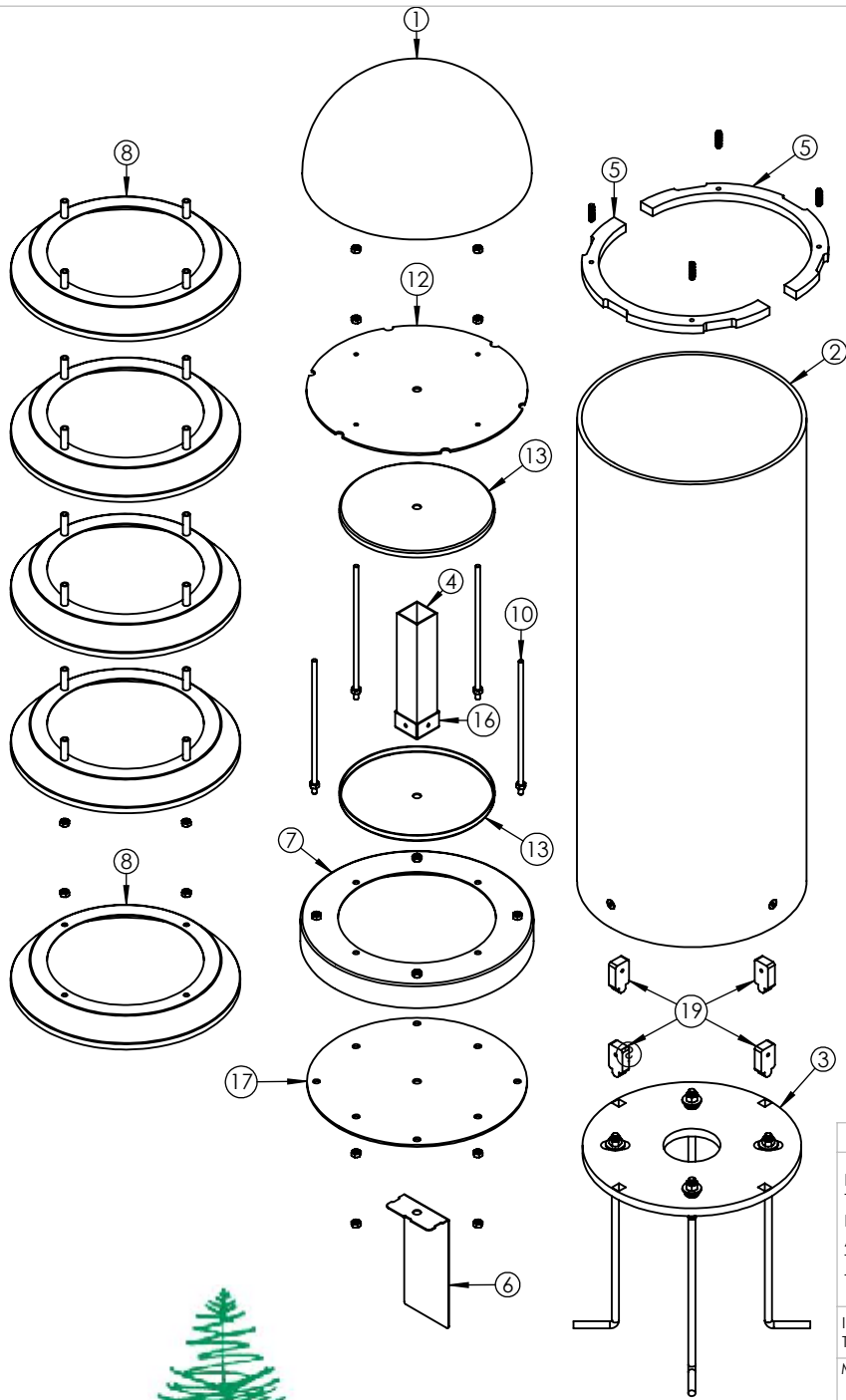

UNLESS OTHERWISE SPECIFIED:
 DIMENSIONS ARE IN INCHES
 TOLERANCES:
 FRACTIONAL ± .003
 ANGULAR: MACH ± .01 BEND ±
 TWO PLACE DECIMAL ±
 THREE PLACE DECIMAL ±.001

INTERPRET GEOMETRIC TOLERANCING PER:
 MATERIAL
 FINISH

ALL BEND RADIUS .030"

APPLICATION DO NOT SCALE DRAWING

	NAME	DATE
DRAWN		
CHECKED		
ENG APPR.		
MFG APPR.		
Q.A.		
COMMENTS:		

TITLE:		
VEN-30-L36-120V-2-WH9-TP-30K		
SIZE	DWG. NO.	REV
A	TICKET 25517	
SCALE: 1:13	WEIGHT:	SHEET 1 OF 15



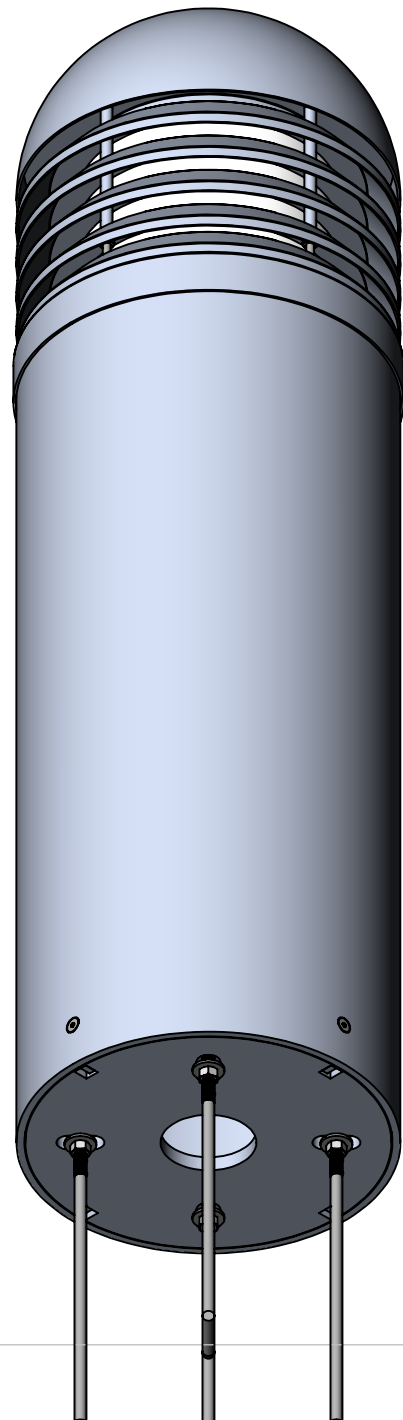

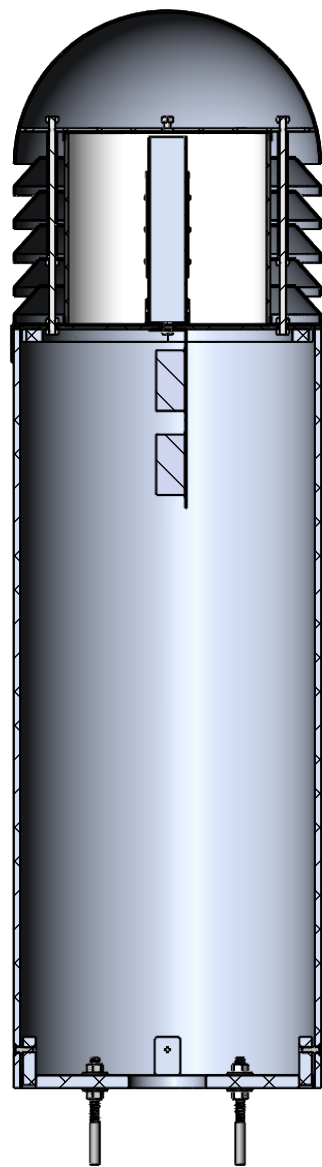
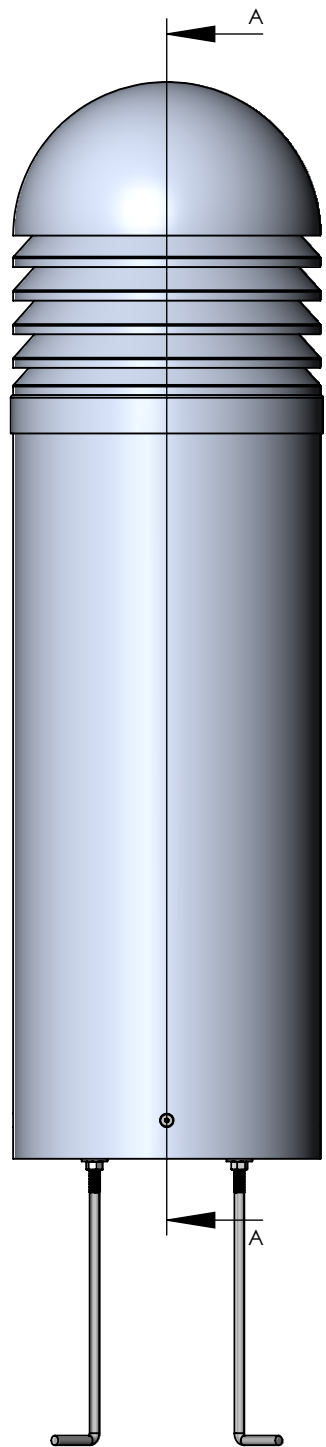

SECTION A-A

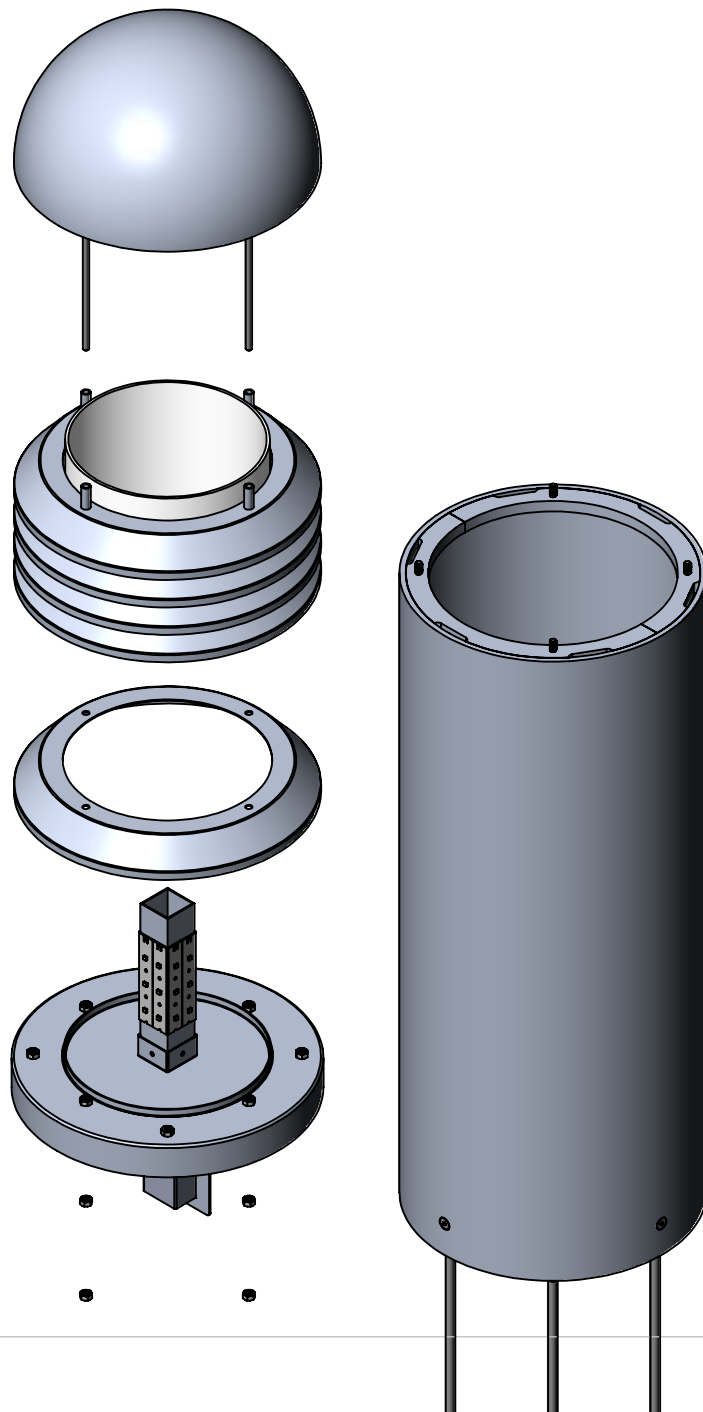

BOTTOM LOUVER IS LOOSE
TO ALLOW BOLTING TO BODY

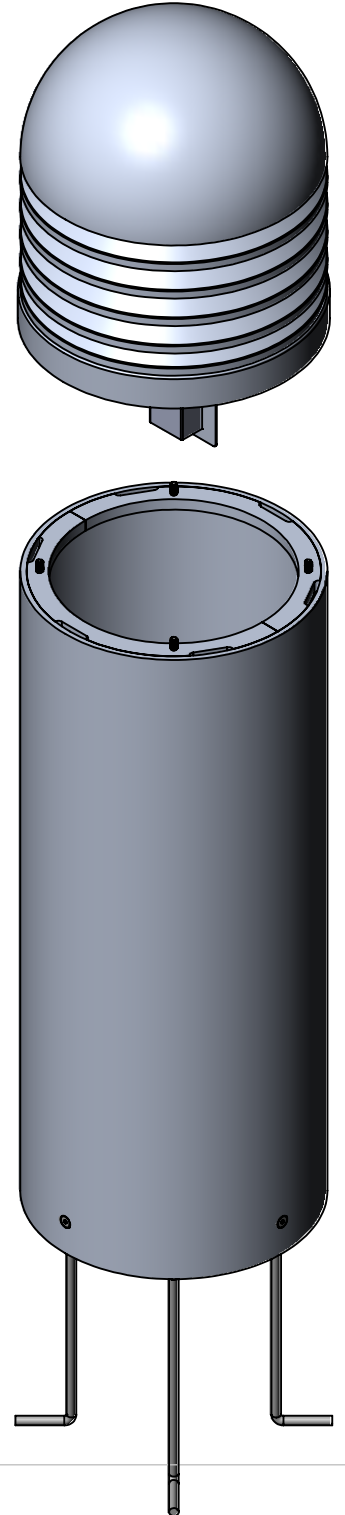
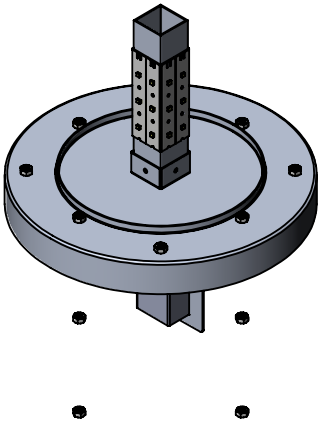
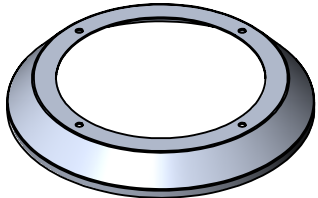
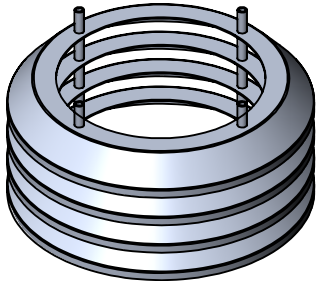
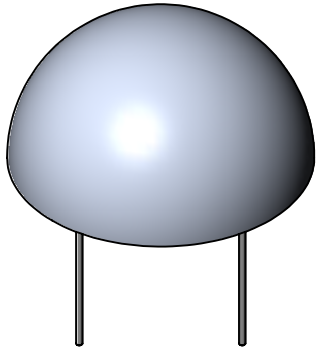

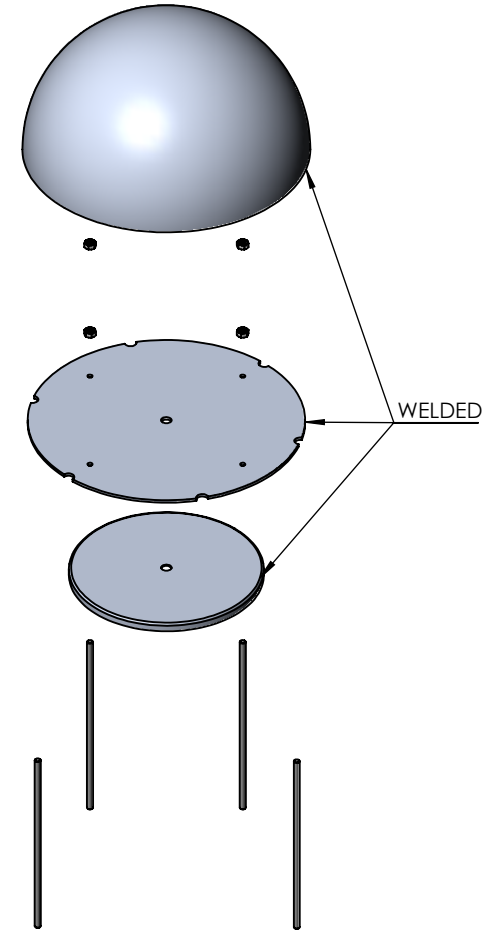
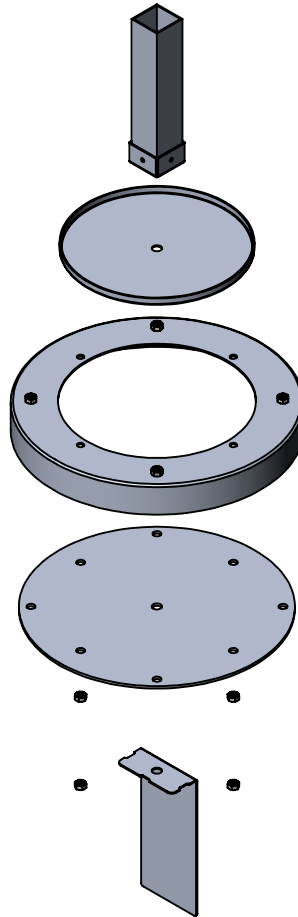
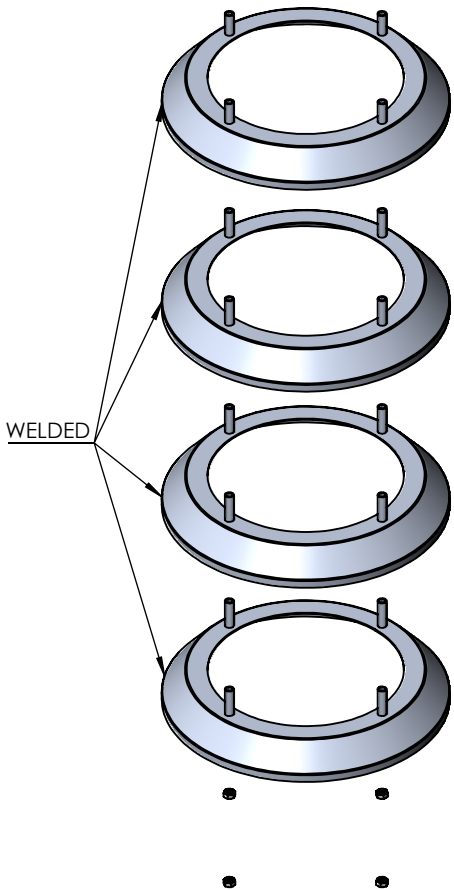
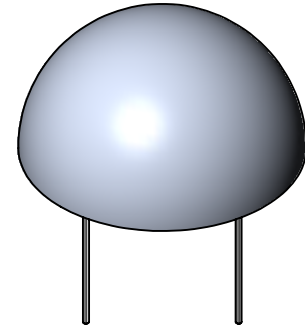
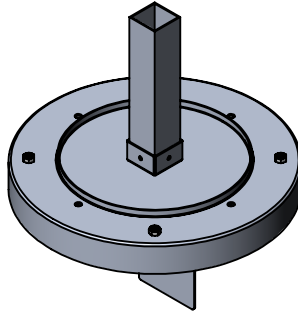
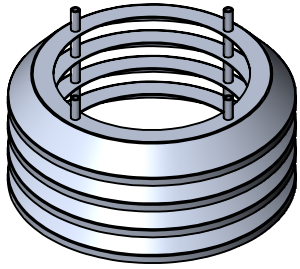

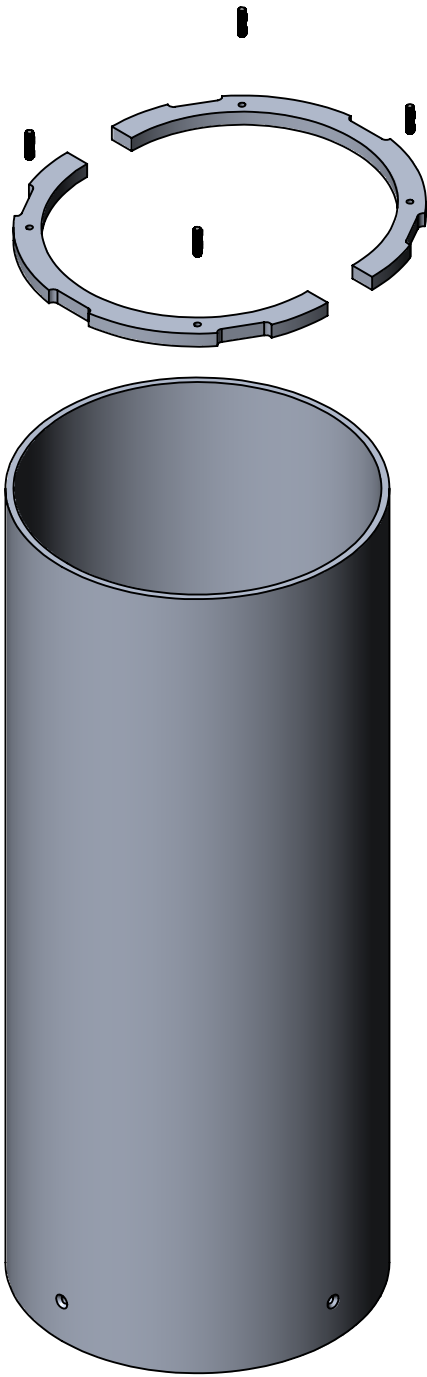

WELDED FLUSH TO TOP



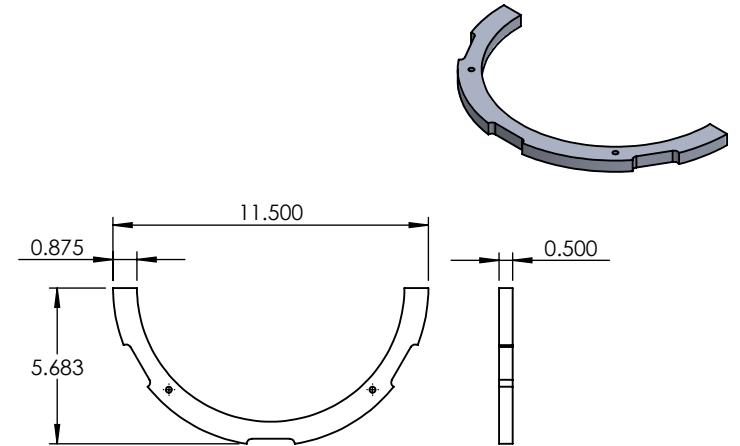
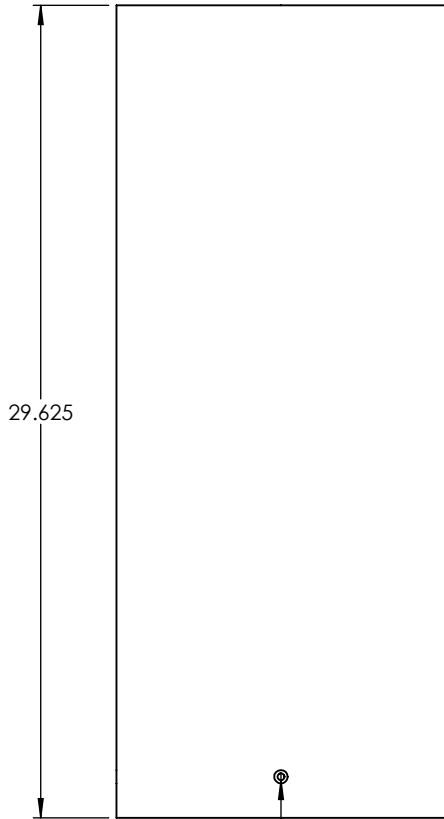
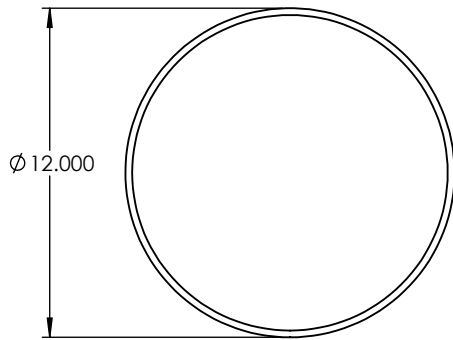

Ø 0.250
CHAMFERED FOR A FLAT-HEAD
1/4-20 HEX SCREW

UNLESS OTHERWISE SPECIFIED:

DIMENSIONS ARE IN INCHES
TOLERANCES:
FRACTIONAL ±
ANGULAR: MACH ± BEND ±
TWO PLACE DECIMAL ±
THREE PLACE DECIMAL ±

INTERPRET GEOMETRIC
TOLERANCING PER:

MATERIAL

FINISH

DO NOT SCALE DRAWING

NAME

DATE

DRAWN

CHECKED

ENG APPR.

MFG APPR.

Q.A.

COMMENTS:

8" DIAMETER CYLINDER

TITLE:

VEN-30-L36-120V-2-WH9-TP-30K

SIZE
A

DWG. NO.

REV

SCALE: 1:7

WEIGHT:

SHEET 7 OF 15

PROPRIETARY AND CONFIDENTIAL

THE INFORMATION CONTAINED IN THIS
DRAWING IS THE SOLE PROPERTY OF
<INSERT COMPANY NAME HERE>. ANY
REPRODUCTION IN PART OR AS A WHOLE
WITHOUT THE WRITTEN PERMISSION OF
<INSERT COMPANY NAME HERE> IS
PROHIBITED.

NEXT ASSY

USED ON

APPLICATION

5

4

3

2

1

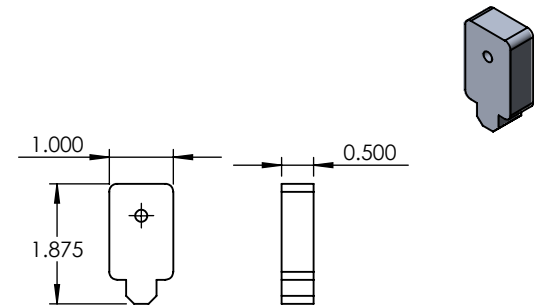
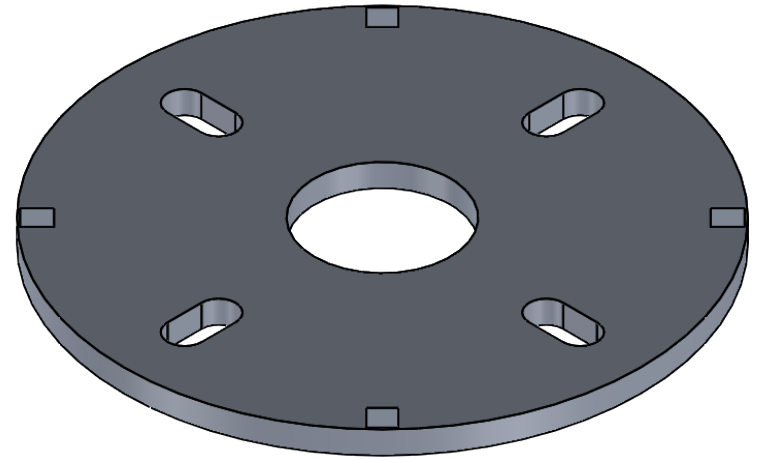
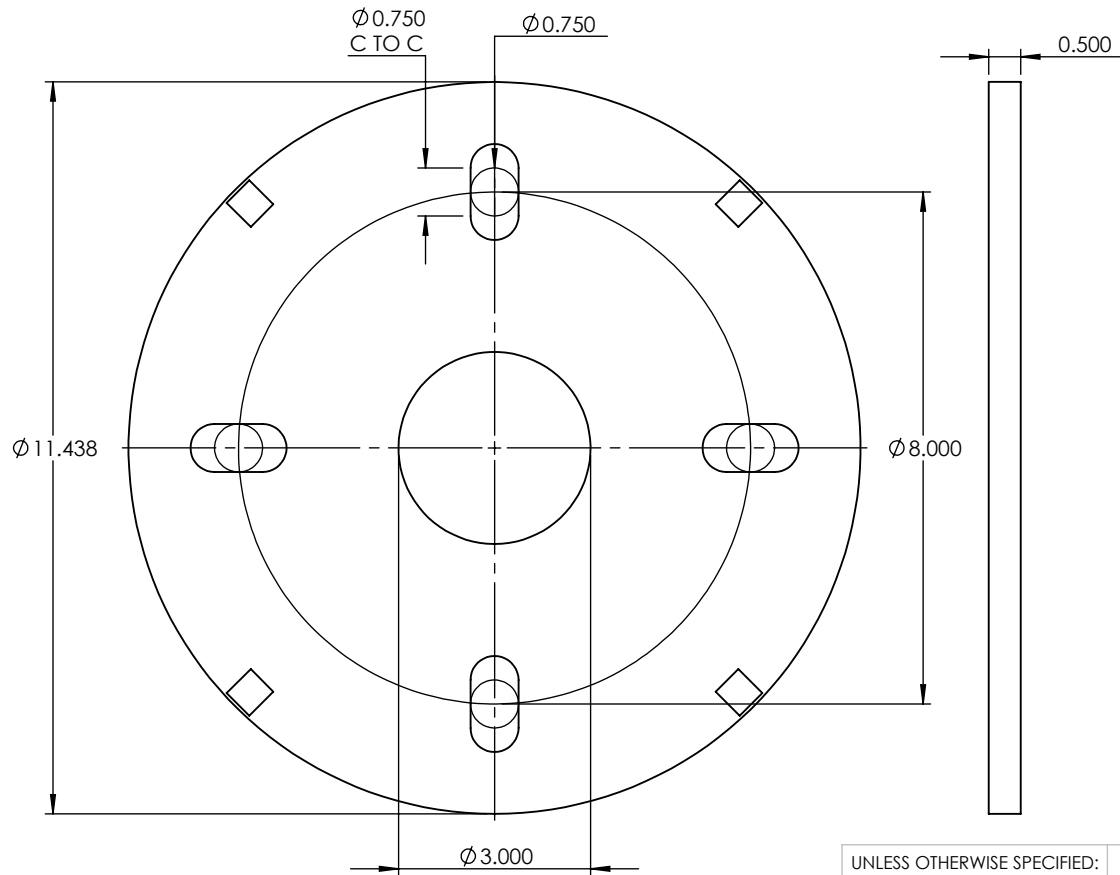

PROPRIETARY AND CONFIDENTIAL
 THE INFORMATION CONTAINED IN THIS DRAWING IS THE SOLE PROPERTY OF <INSERT COMPANY NAME HERE>. ANY REPRODUCTION IN PART OR AS A WHOLE WITHOUT THE WRITTEN PERMISSION OF <INSERT COMPANY NAME HERE> IS PROHIBITED.

NEXT ASSY	USED ON
APPLICATION	

UNLESS OTHERWISE SPECIFIED:	NAME	DATE
DIMENSIONS ARE IN INCHES	DRAWN	
TOLERANCES:	CHECKED	
FRACTIONAL \pm	ENG APPR.	
ANGULAR: MACH \pm BEND \pm	MFG APPR.	
TWO PLACE DECIMAL \pm	Q.A.	
THREE PLACE DECIMAL \pm	COMMENTS:	
INTERPRET GEOMETRIC TOLERANCING PER:		
MATERIAL		
FINISH		
DO NOT SCALE DRAWING		

ALUMINUM 0.500" PLATE		
TITLE:		
VEN-30-L36-120V-2-WH9-TP-30K		
SIZE	DWG. NO.	REV
A		
SCALE: 1:3	WEIGHT:	SHEET 8 OF 15

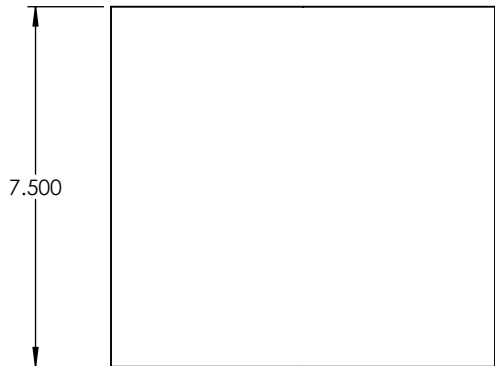
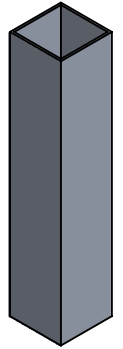
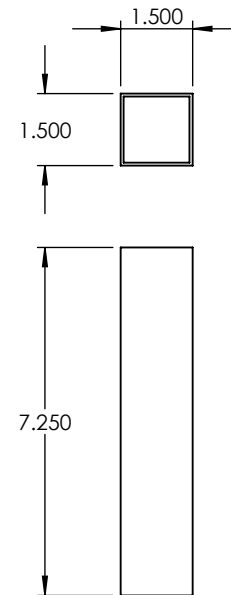
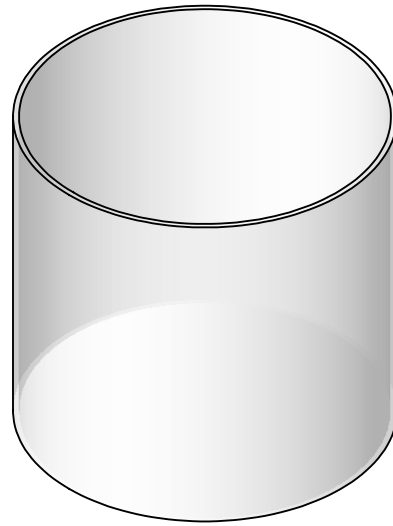
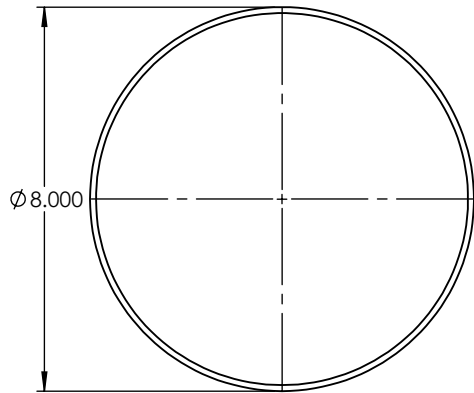

UNLESS OTHERWISE SPECIFIED: DIMENSIONS ARE IN INCHES TOLERANCES: FRACTIONAL ± ANGULAR: MACH ± BEND ± TWO PLACE DECIMAL ± THREE PLACE DECIMAL ±	NAME	DATE	ACRYLIC		
	DRAWN				TITLE:
	CHECKED		VEN-30-L36-120V-2-WH9-TP-30K		
	ENG APPR.		SIZE	DWG. NO.	REV
	MFG APPR.		A		
INTERPRET GEOMETRIC TOLERANCING PER:	Q.A.	COMMENTS:			
MATERIAL					
FINISH					
APPLICATION	DO NOT SCALE DRAWING	SCALE: 1:4	WEIGHT:	SHEET 9 OF 15	

PROPRIETARY AND CONFIDENTIAL
THE INFORMATION CONTAINED IN THIS DRAWING IS THE SOLE PROPERTY OF <INSERT COMPANY NAME HERE>. ANY REPRODUCTION IN PART OR AS A WHOLE WITHOUT THE WRITTEN PERMISSION OF <INSERT COMPANY NAME HERE> IS PROHIBITED.

NEXT ASSY	USED ON
APPLICATION	

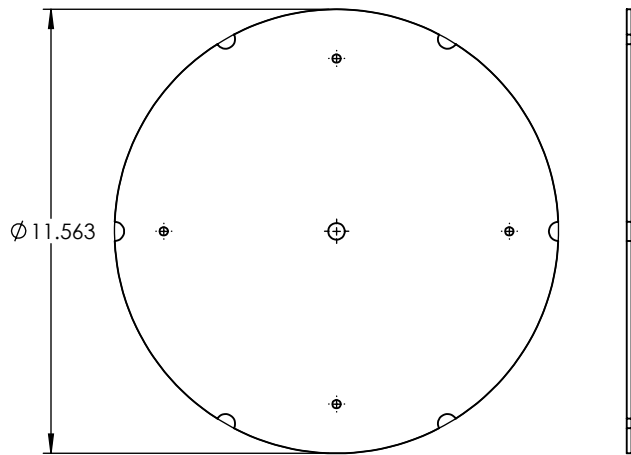
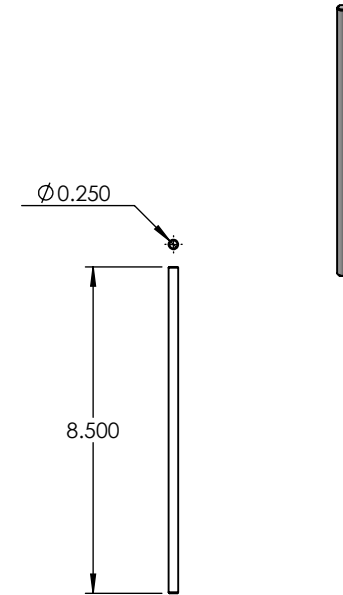
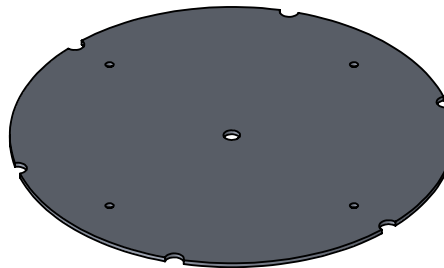
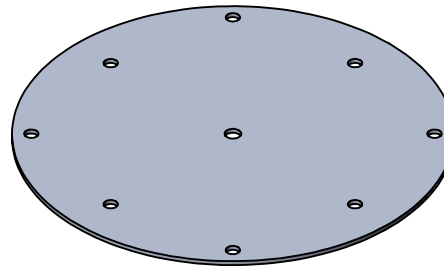
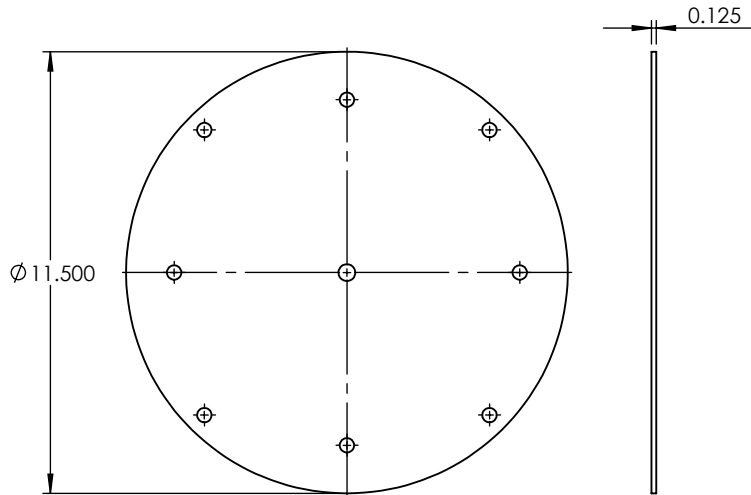

UNLESS OTHERWISE SPECIFIED:		NAME	DATE	ALUMINUM 0.125" PLATE	
DIMENSIONS ARE IN INCHES		DRAWN			
TOLERANCES:		CHECKED		VEN-30-L36-120V-2-WH9-TP-30K	
FRACTIONAL ±		ENG APPR.		SIZE DWG. NO. REV	
ANGULAR: MACH ± BEND ±		MFG APPR.		A	
TWO PLACE DECIMAL ±		Q.A.		SCALE: 1:5 WEIGHT: SHEET 10 OF 15	
THREE PLACE DECIMAL ±		COMMENTS:			
INTERPRET GEOMETRIC TOLERANCING PER:					
MATERIAL					
FINISH					
NEXT ASSY		USED ON			
APPLICATION		DO NOT SCALE DRAWING			

PROPRIETARY AND CONFIDENTIAL
 THE INFORMATION CONTAINED IN THIS DRAWING IS THE SOLE PROPERTY OF <INSERT COMPANY NAME HERE>. ANY REPRODUCTION IN PART OR AS A WHOLE WITHOUT THE WRITTEN PERMISSION OF <INSERT COMPANY NAME HERE> IS PROHIBITED.

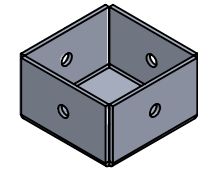
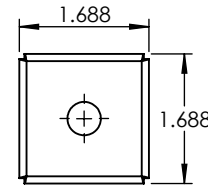
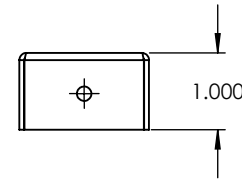
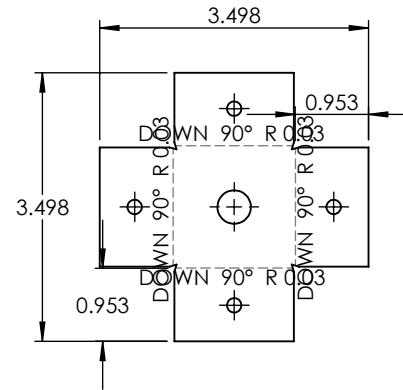
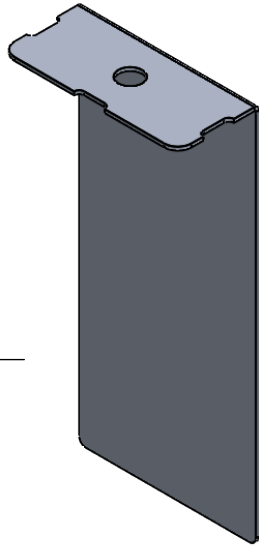
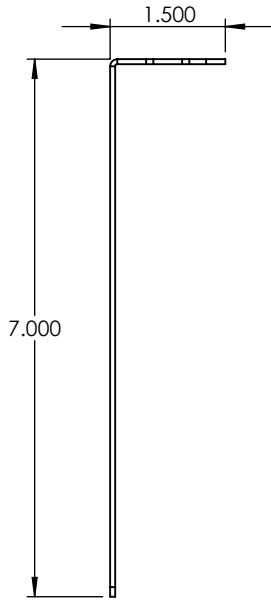
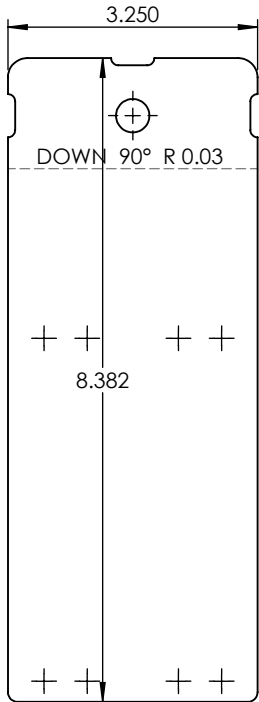

		UNLESS OTHERWISE SPECIFIED:		NAME	DATE		
		DIMENSIONS ARE IN INCHES		DRAWN		TITLE:	
		TOLERANCES:		CHECKED		VEN-30-L36-120V-2-WH9-TP-30K	
		FRACTIONAL ±		ENG APPR.		SIZE DWG. NO. REV	
		ANGULAR: MACH ± BEND ±		MFG APPR.		A	
		TWO PLACE DECIMAL ±		Q.A.		SCALE: 1:2.5 WEIGHT:	
		THREE PLACE DECIMAL ±		COMMENTS:		SHEET 11 OF 15	
		INTERPRET GEOMETRIC TOLERANCING PER:					
		MATERIAL					
NEXT ASSY	USED ON	FINISH					
APPLICATION		DO NOT SCALE DRAWING					

ITEM NO.	PART NUMBER	DESCRIPTION	QTY.
1	VEN-30-L36-120V-2-WH9-TP-30K-12" SPUN SPHERE	SPUN ALUMINUM 0.080"	1

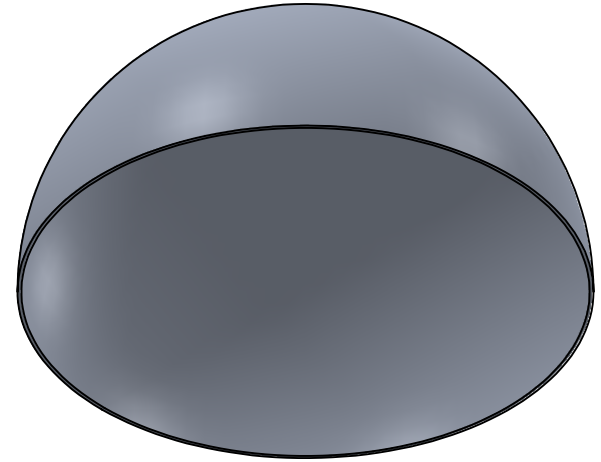
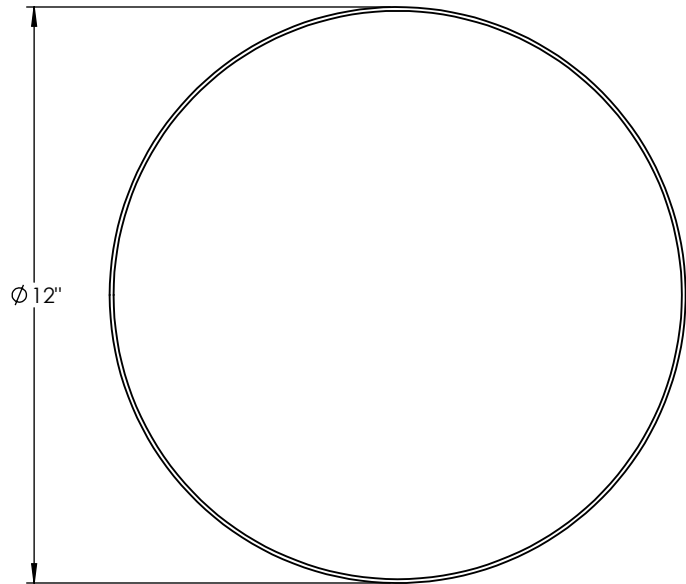
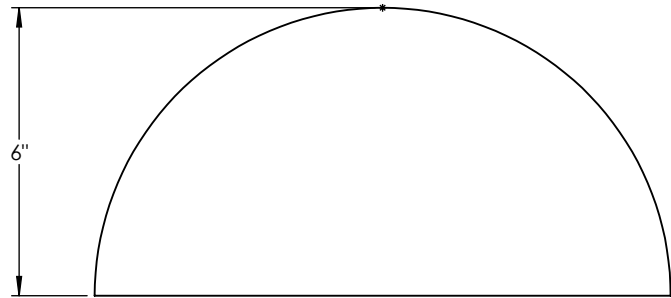

PROPRIETARY AND CONFIDENTIAL
 THE INFORMATION CONTAINED IN THIS DRAWING IS THE SOLE PROPERTY OF <INSERT COMPANY NAME HERE>. ANY REPRODUCTION IN PART OR AS A WHOLE WITHOUT THE WRITTEN PERMISSION OF <INSERT COMPANY NAME HERE> IS PROHIBITED.

		UNLESS OTHERWISE SPECIFIED:		NAME	DATE
		DIMENSIONS ARE IN INCHES	DRAWN		
		TOLERANCES:	CHECKED		
		FRACTIONAL ±	ENG APPR.		
		ANGULAR: MACH ± BEND ±	MFG APPR.		
		TWO PLACE DECIMAL ±	Q.A.		
		THREE PLACE DECIMAL ±	COMMENTS:		
		INTERPRET GEOMETRIC TOLERANCING PER:			
		MATERIAL			
		FINISH			
NEXT ASSY	USED ON				
APPLICATION		DO NOT SCALE DRAWING			

SPUN ALUMINUM 0.080"		
TITLE:		
VEN-30-L36-120V-2-WH9-TP-30K		
SIZE	DWG. NO.	REV
A		
SCALE: 1:4	WEIGHT:	SHEET 12 OF 15

ITEM NO.	PART NUMBER	DESCRIPTION	QTY.
1	VEN-30-L36-120V-2-WH9-TP-30K-8" SPUN LENS CAP	SPUN ALUMINUM 0.080"	1

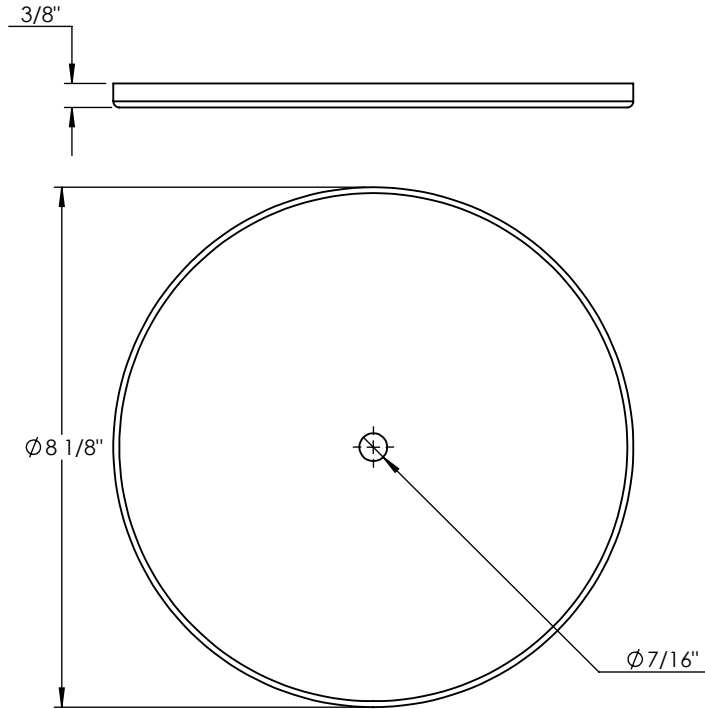
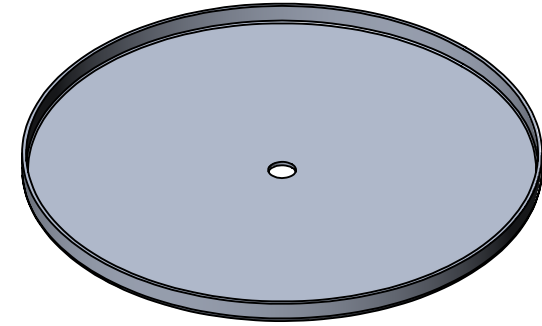

UNLESS OTHERWISE SPECIFIED: DIMENSIONS ARE IN INCHES TOLERANCES: FRACTIONAL ± ANGULAR: MACH ± BEND ± TWO PLACE DECIMAL ± THREE PLACE DECIMAL ± INTERPRET GEOMETRIC TOLERANCING PER: MATERIAL FINISH		NAME	DATE	SPUN ALUMINUM 0.080" TITLE: VEN-30-L36-120V-2-WH9-TP-30K			
	DRAWN						SIZE
	CHECKED			SCALE: 1:3 WEIGHT: SHEET 13 OF 15			
	ENG APPR.						
	MFG APPR.						
	Q.A.						
	COMMENTS:						

PROPRIETARY AND CONFIDENTIAL
 THE INFORMATION CONTAINED IN THIS DRAWING IS THE SOLE PROPERTY OF <INSERT COMPANY NAME HERE>. ANY REPRODUCTION IN PART OR AS A WHOLE WITHOUT THE WRITTEN PERMISSION OF <INSERT COMPANY NAME HERE> IS PROHIBITED.

NEXT ASSY	USED ON
APPLICATION	

DO NOT SCALE DRAWING

ITEM NO.	PART NUMBER	DESCRIPTION	QTY.
1	VEN-30-L36-120V-2-WH9-TP-30K-SPUN CYLINDER COVER	SPUN ALUMINUM 0.080"	1

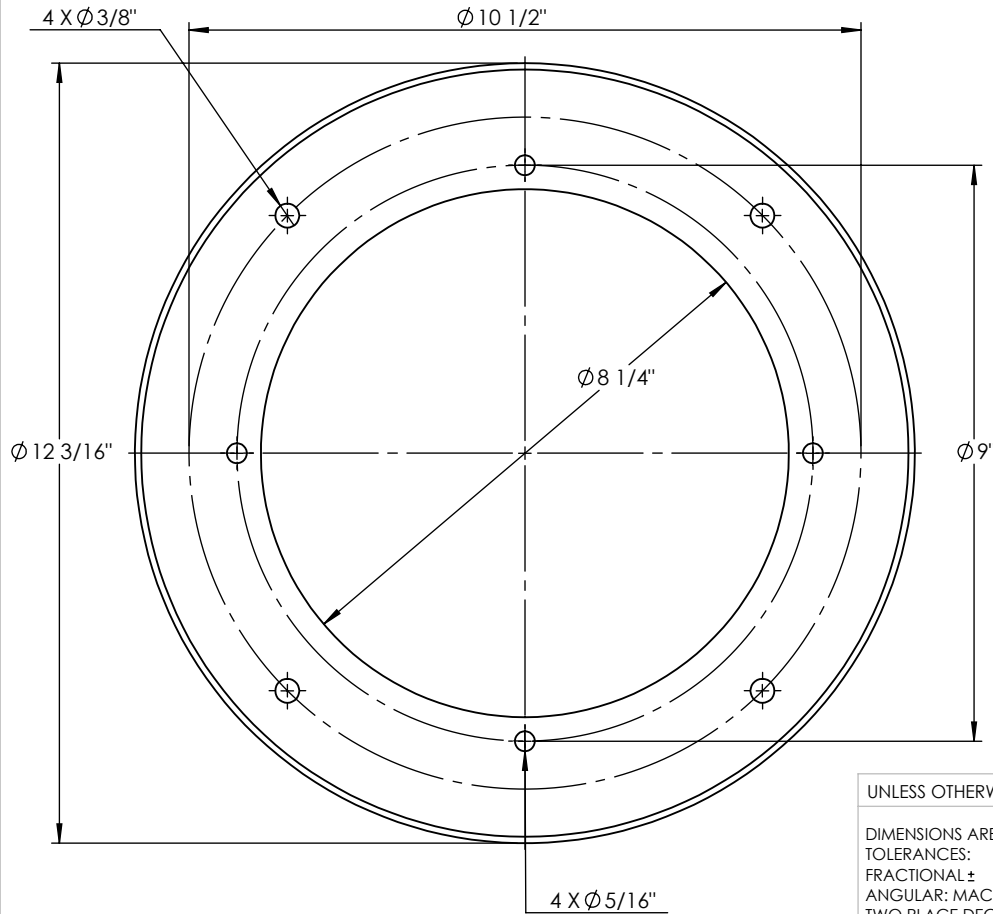
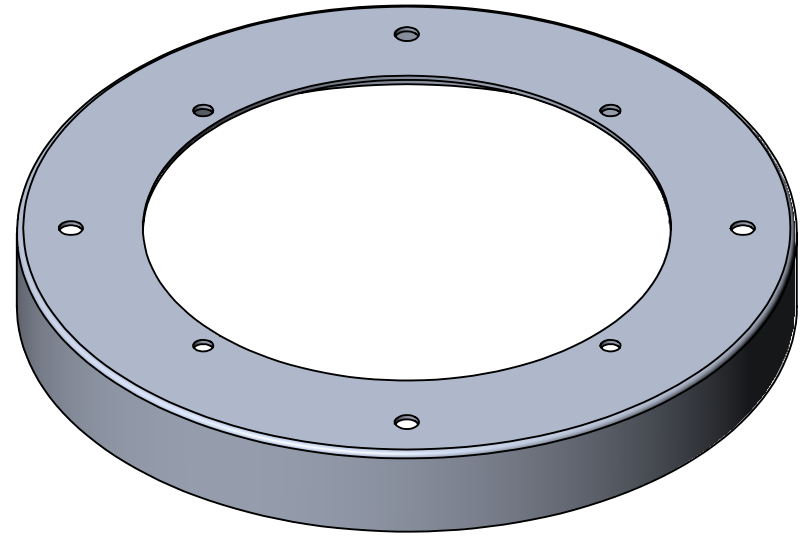
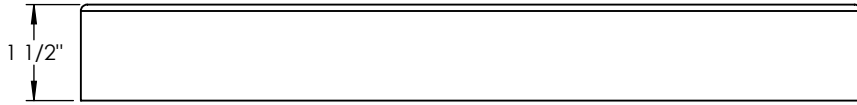

UNLESS OTHERWISE SPECIFIED:

DIMENSIONS ARE IN INCHES
 TOLERANCES:
 FRACTIONAL \pm
 ANGULAR: MACH \pm BEND \pm
 TWO PLACE DECIMAL \pm
 THREE PLACE DECIMAL \pm

INTERPRET GEOMETRIC
 TOLERANCING PER:

MATERIAL

FINISH

DO NOT SCALE DRAWING

	NAME	DATE
DRAWN		
CHECKED		
ENG APPR.		
MFG APPR.		
Q.A.		
COMMENTS:		

SPUN ALUMINUM 0.080"

TITLE:

VEN-30-L36-120V-2-WH9-TP-30K

SIZE DWG. NO. REV

A

SCALE: 1:3 WEIGHT: SHEET 14 OF 15

PROPRIETARY AND CONFIDENTIAL
 THE INFORMATION CONTAINED IN THIS
 DRAWING IS THE SOLE PROPERTY OF
 <INSERT COMPANY NAME HERE>. ANY
 REPRODUCTION IN PART OR AS A WHOLE
 WITHOUT THE WRITTEN PERMISSION OF
 <INSERT COMPANY NAME HERE> IS
 PROHIBITED.

APPLICATION	USED ON
NEXT ASSY	

5

4

3

2

1

ITEM NO.	PART NUMBER	DESCRIPTION	QTY.
1	VEN-30-L36-120V-2-WH9-TP-30K-REFLECTOR LOUVER	SPUN ALUMINUM 0.0635"	1

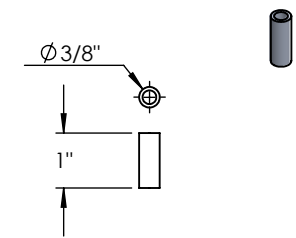
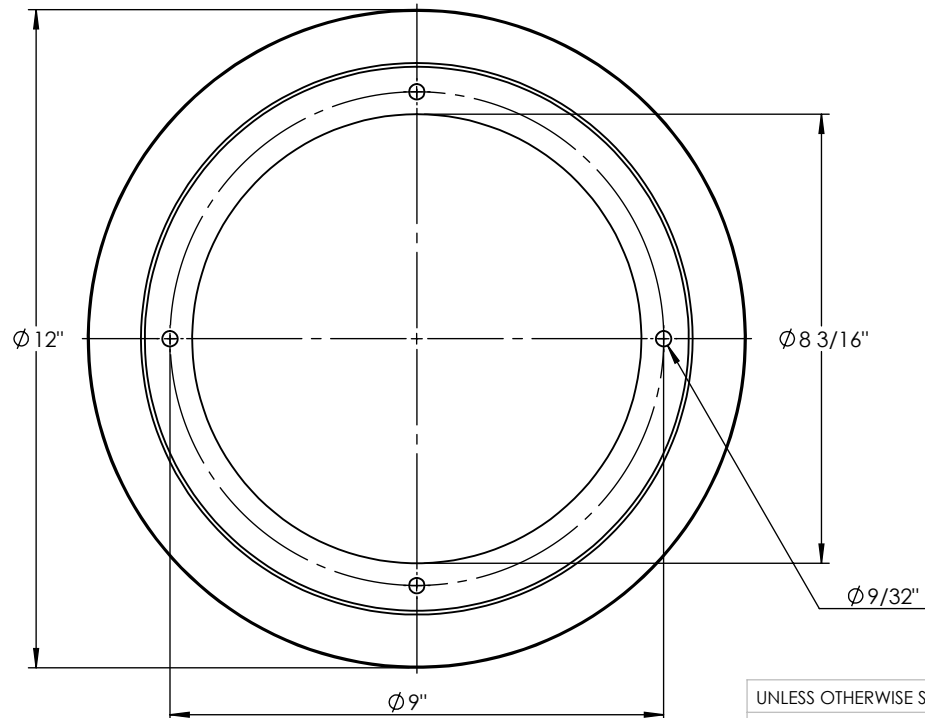
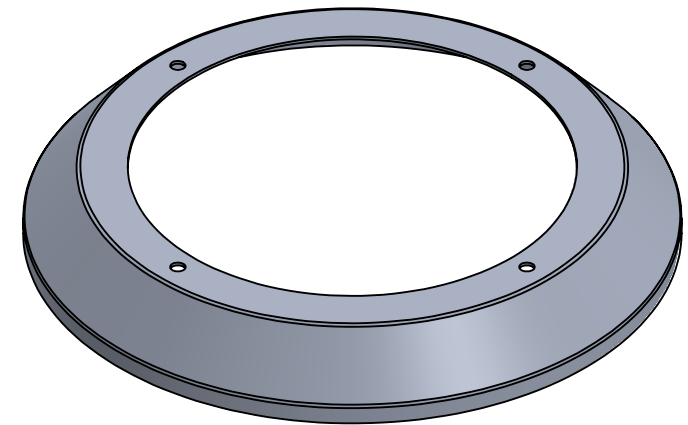
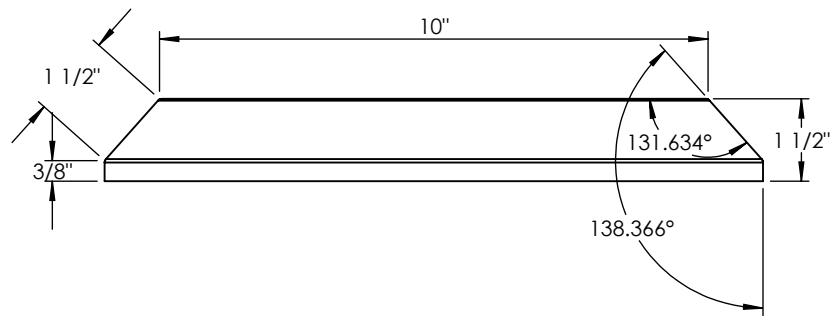

UNLESS OTHERWISE SPECIFIED:		NAME	DATE	SPUN ALUMINUM 0.0635"	
DIMENSIONS ARE IN INCHES TOLERANCES: FRACTIONAL ± ANGULAR: MACH ± BEND ± TWO PLACE DECIMAL ± THREE PLACE DECIMAL ±		DRAWN			
INTERPRET GEOMETRIC TOLERANCING PER:		CHECKED		VEN-30-L36-120V-2-WH9-TP-30K	
MATERIAL		ENG APPR.		SIZE	DWG. NO.
FINISH		MFG APPR.		A	
NEXT ASSY		Q.A.		SCALE: 1:3.5	WEIGHT:
USED ON		COMMENTS:		SHEET 15 OF 15	
APPLICATION					
DO NOT SCALE DRAWING					

PROPRIETARY AND CONFIDENTIAL
THE INFORMATION CONTAINED IN THIS DRAWING IS THE SOLE PROPERTY OF <INSERT COMPANY NAME HERE>. ANY REPRODUCTION IN PART OR AS A WHOLE WITHOUT THE WRITTEN PERMISSION OF <INSERT COMPANY NAME HERE> IS PROHIBITED.