

ITEM NO.	PART NUMBER	DESCRIPTION	QTY.	CUT
1	202212L-AB-A-HH-35K-REFLECTOR PLATE	22 GAUGE	1	
2	202212L-AB-A-HH-35K-BACKPLATE	22 GAUGE	1	
3	202212L-AB-A-HH-35K-BACKPLATE TAB	22 GAUGE	4	
4	202212L-AB-A-HH-35K-FIREPLATE	22 GAUGE	1	
5	202212L-AB-A-HH-35K-DRIVER BRACKET	22 GAUGE	1	
6	202212L-AB-A-HH-35K-TOP CAP	22 GAUGE	1	
7	202212L-AB-A-HH-35K-TOP UNDERCAP	22 GAUGE	1	
8	202212L-AB-A-HH-35K-FRAME CAP	22 GAUGE	2	
9	202212L-AB-A-HH-35K-FRAME	22 GAUGE	1	
10	202212L-AB-A-HH-35K-FRAME BACK	22 GAUGE	1	
11	202212L-AB-A-HH-35K-TUBE BRACKET	22 GAUGE	1	
12	202212L-AB-A-HH-35K-ACRYLIC	ACRYLIC	4	
14	202212L-AB-A-HH-35K-ACRYLIC	ACRYLIC	1	
15	202212L-AB-A-HH-35K-SMALL TUBE	5/8" ROUND ALUMINUM TUBE	1	
16	202212L-AB-A-HH-35K-SQUARE TUBE	1" SQUARE ALUMINUM TUBE	1	
17	BRASS L JOINT	BRASS JOINT	1	
18	Espen VEL19070MVH-1	DRIVER	1	
19	AltalLED_PN1012_RevE	LED	4	

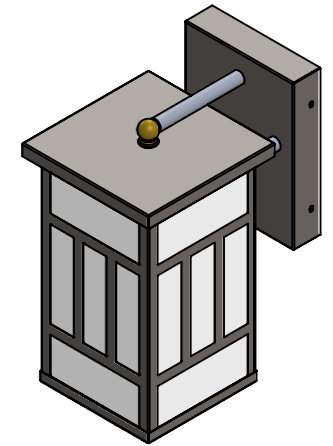
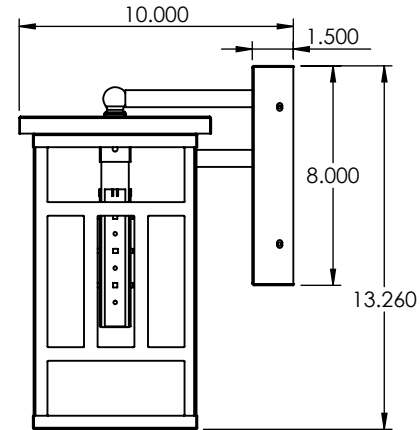
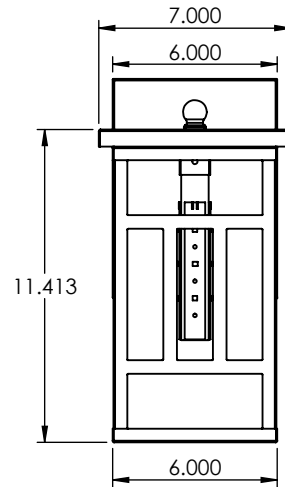
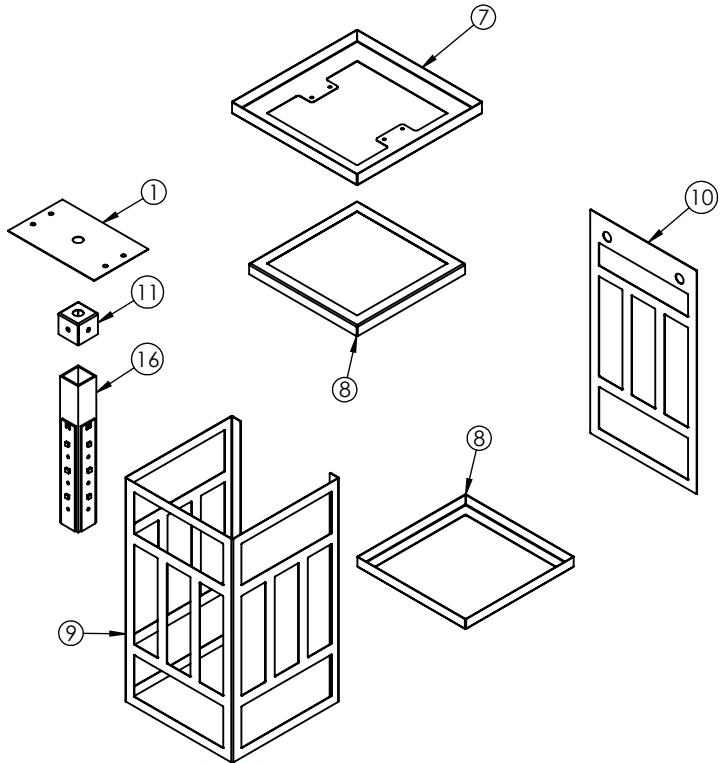

UNLESS OTHERWISE SPECIFIED:

DIMENSIONS ARE IN INCHES
 TOLERANCES:
 FRACTIONAL ± .003
 ANGULAR: MACH ± .01 BEND ±
 TWO PLACE DECIMAL ±
 THREE PLACE DECIMAL ±.001

INTERPRET GEOMETRIC
 TOLERANCING PER:

MATERIAL

FINISH

	NAME	DATE
DRAWN		
CHECKED		
ENG APPR.		
MFG APPR.		
Q.A.		
COMMENTS:		

TITLE:

202212L-AB-A-HH-35K

SIZE	DWG. NO.	REV
A	TICKET 25519	
SCALE: 1:7.5	WEIGHT:	SHEET 1 OF 9

EVERGREEN LIGHTING

ALL BEND RADIUS .030"

APPLICATION

DO NOT SCALE DRAWING

5

4

3

2

1

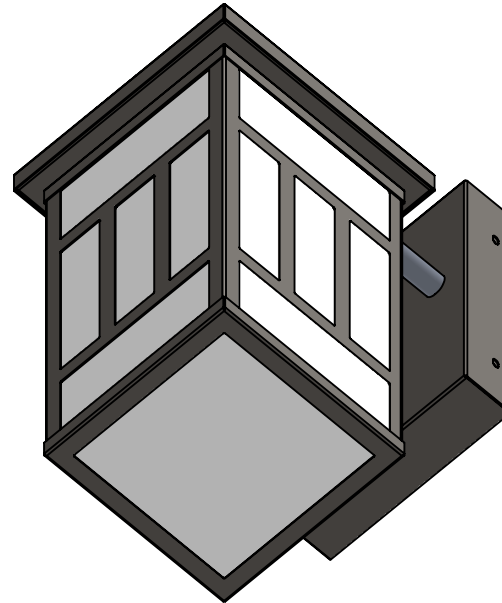
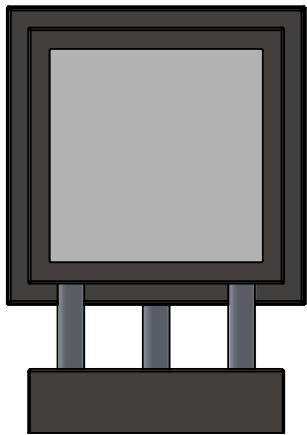
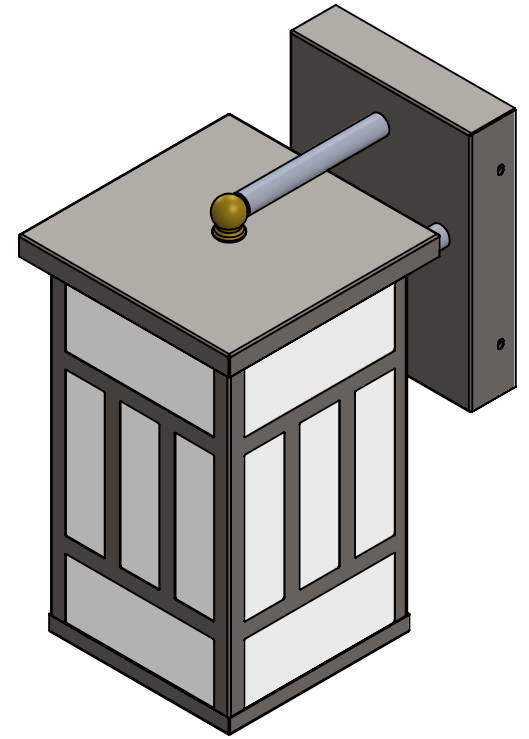
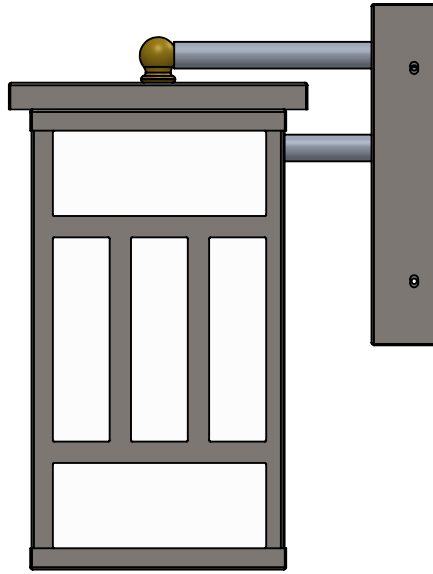
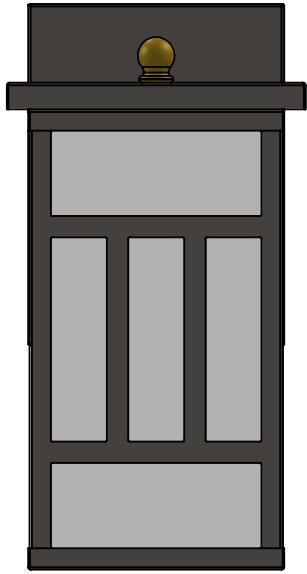

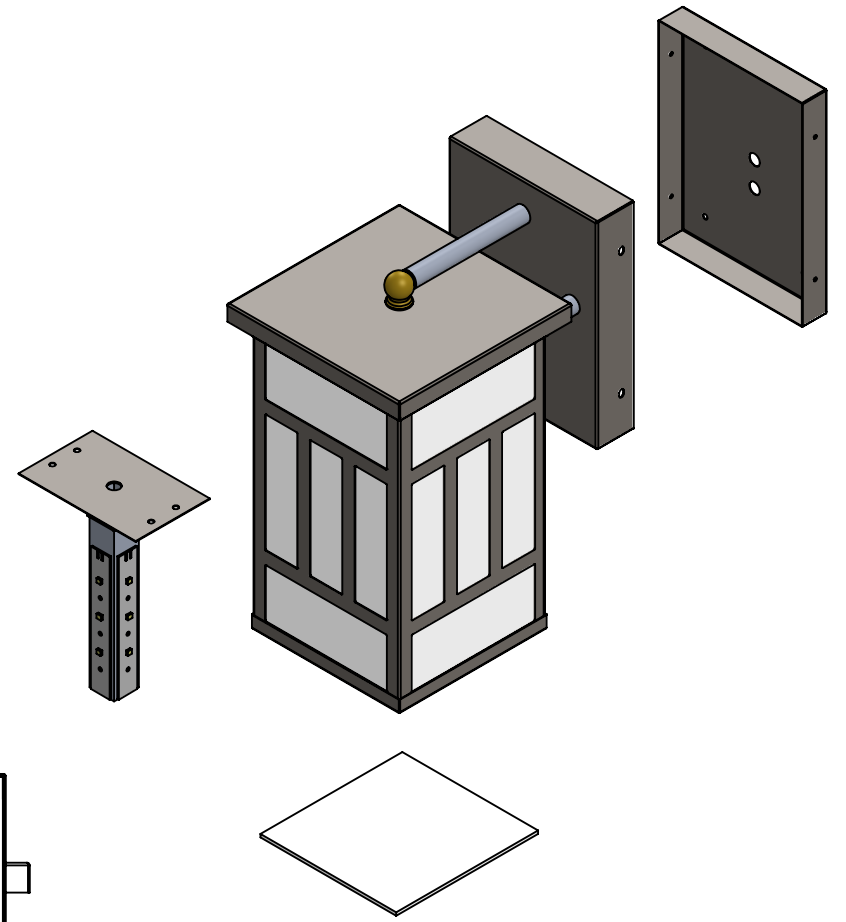
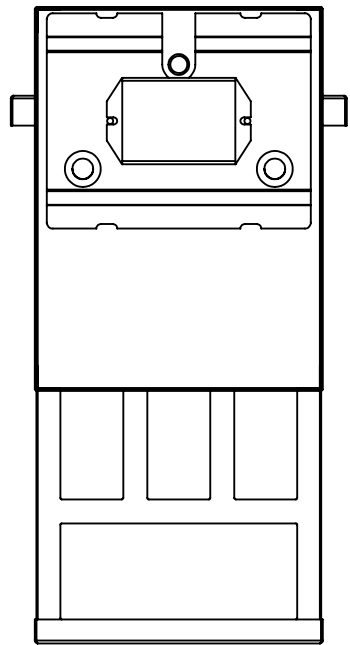
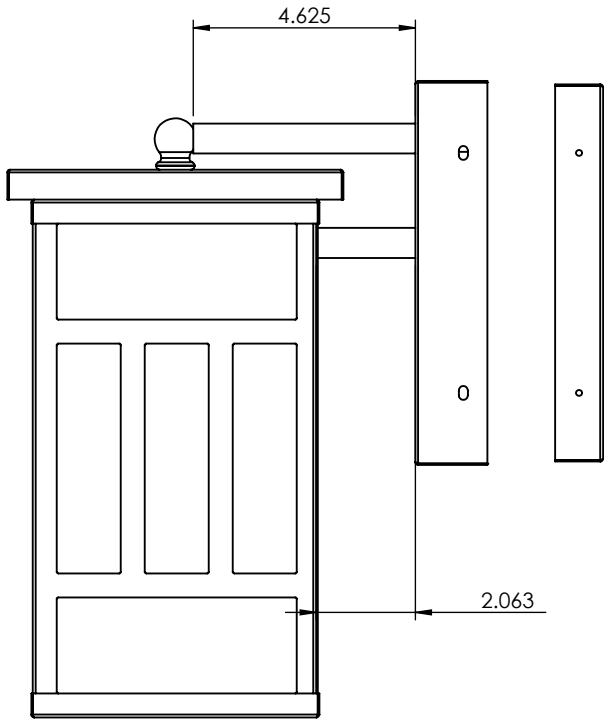

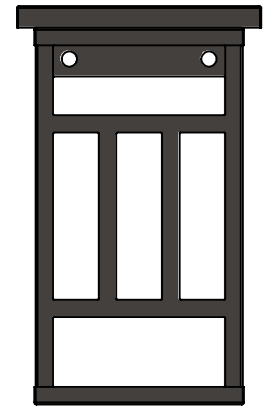
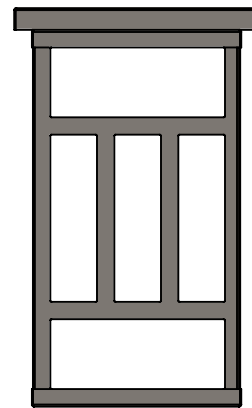
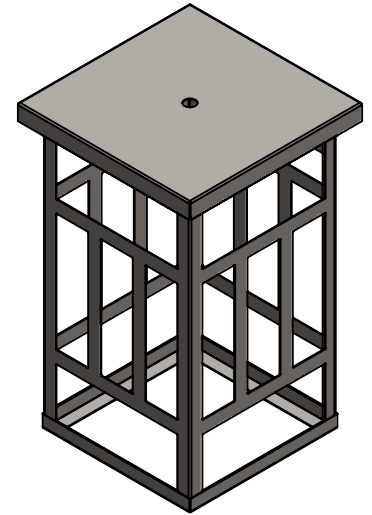
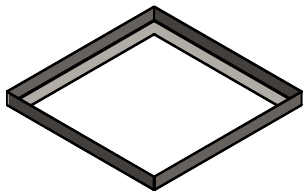
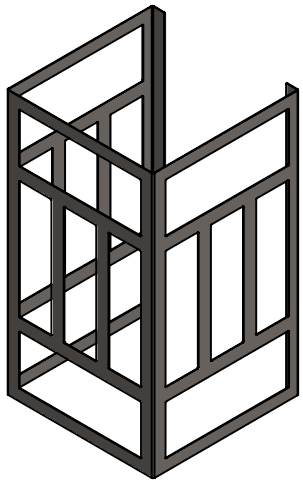
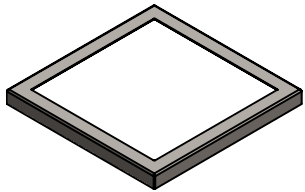
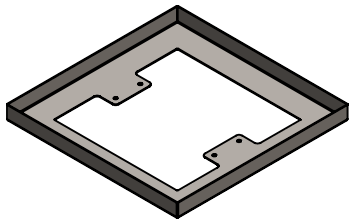
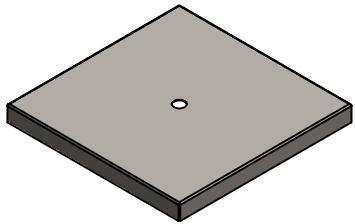

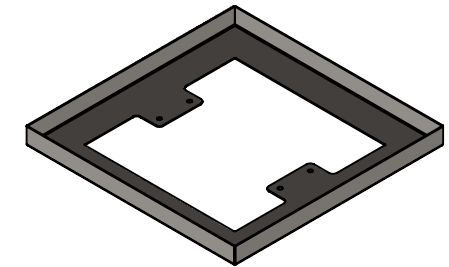
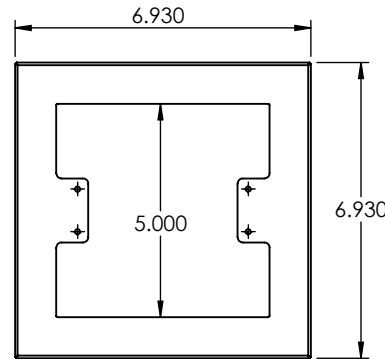
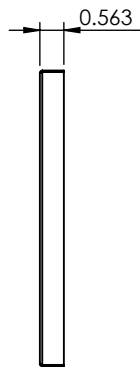
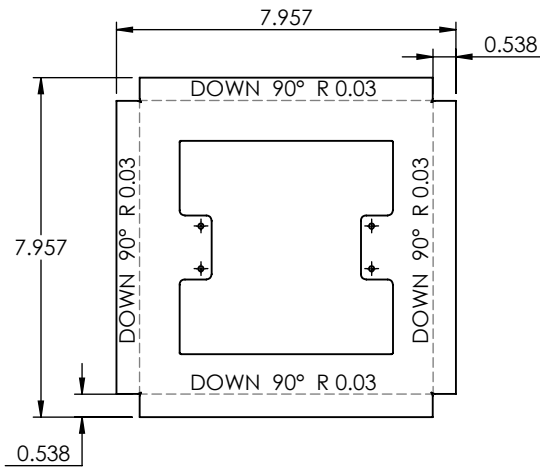
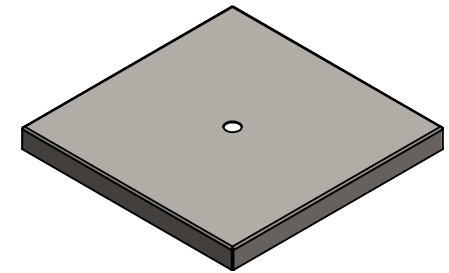
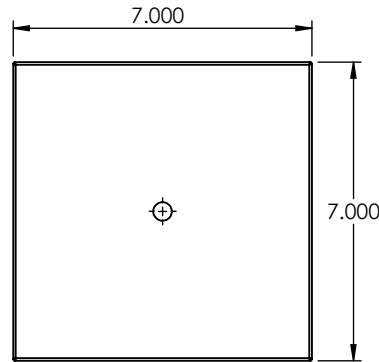
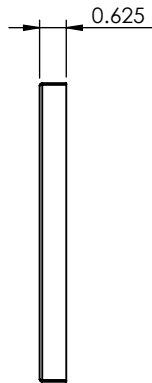
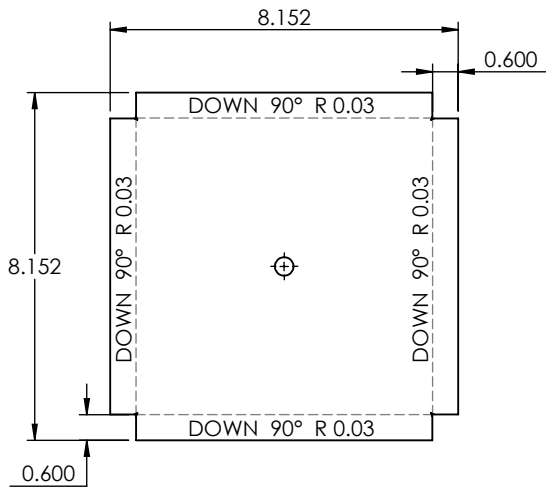

PROPRIETARY AND CONFIDENTIAL
 THE INFORMATION CONTAINED IN THIS DRAWING IS THE SOLE PROPERTY OF <INSERT COMPANY NAME HERE>. ANY REPRODUCTION IN PART OR AS A WHOLE WITHOUT THE WRITTEN PERMISSION OF <INSERT COMPANY NAME HERE> IS PROHIBITED.

		UNLESS OTHERWISE SPECIFIED:		NAME	DATE
		DIMENSIONS ARE IN INCHES	DRAWN		
		TOLERANCES:	CHECKED		
		FRACTIONAL ±	ENG APPR.		
		ANGULAR: MACH ± BEND ±	MFG APPR.		
		TWO PLACE DECIMAL ±	Q.A.		
		THREE PLACE DECIMAL ±	COMMENTS:		
		INTERPRET GEOMETRIC TOLERANCING PER:			
		MATERIAL			
NEXT ASSY	USED ON	FINISH			
APPLICATION		DO NOT SCALE DRAWING			

22 GAUGE		
TITLE:		
202212L-AB-A-HH-35K		
SIZE	DWG. NO.	REV
A		
SCALE: 1:4.5WEIGHT:		SHEET 5 OF 9

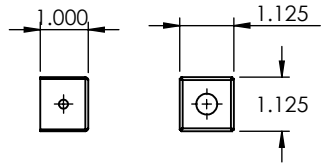
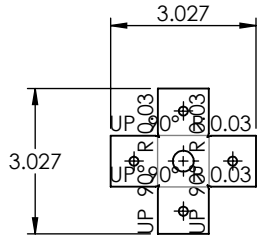
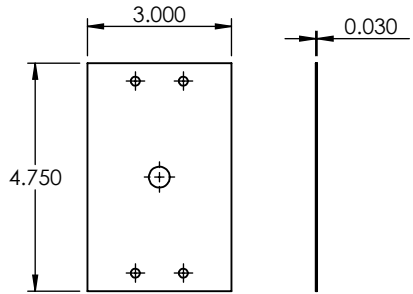
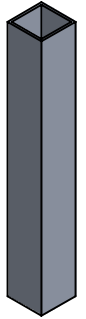
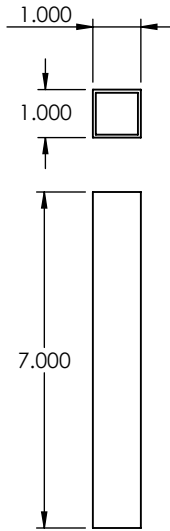
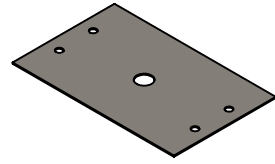
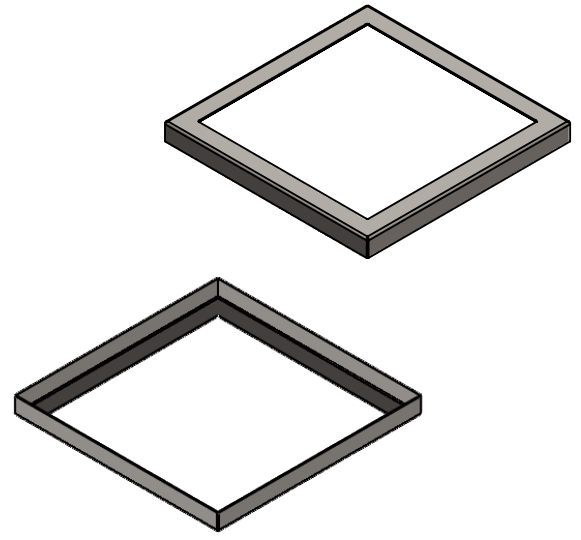
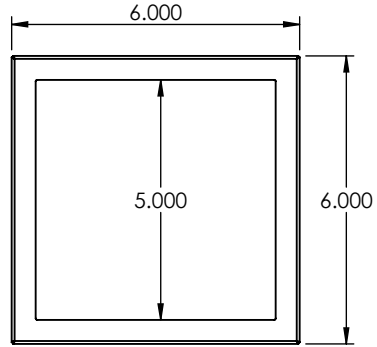
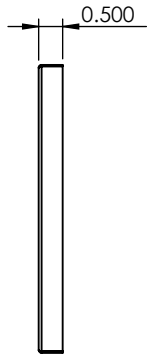
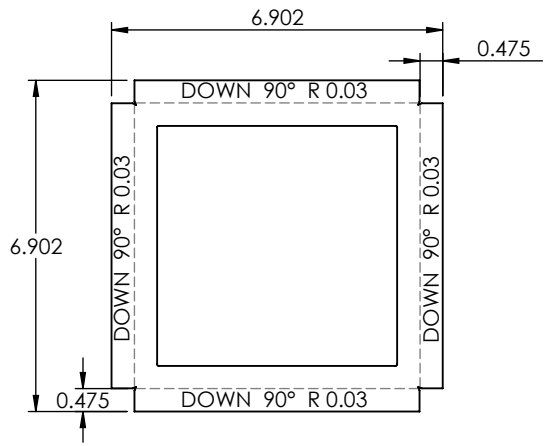

PROPRIETARY AND CONFIDENTIAL
 THE INFORMATION CONTAINED IN THIS DRAWING IS THE SOLE PROPERTY OF <INSERT COMPANY NAME HERE>. ANY REPRODUCTION IN PART OR AS A WHOLE WITHOUT THE WRITTEN PERMISSION OF <INSERT COMPANY NAME HERE> IS PROHIBITED.

		UNLESS OTHERWISE SPECIFIED:	NAME	DATE
		DIMENSIONS ARE IN INCHES	DRAWN	
		TOLERANCES:	CHECKED	
		FRACTIONAL ±	ENG APPR.	
		ANGULAR: MACH ± BEND ±	MFG APPR.	
		TWO PLACE DECIMAL ±	Q.A.	
		THREE PLACE DECIMAL ±	COMMENTS:	
		INTERPRET GEOMETRIC TOLERANCING PER:		
		MATERIAL		
NEXT ASSY	USED ON	FINISH		
APPLICATION		DO NOT SCALE DRAWING		

TITLE:		
202212L-AB-A-HH-35K		
SIZE	DWG. NO.	REV
A		
SCALE: 1:4	WEIGHT:	SHEET 6 OF 9

5

4

3

2

1

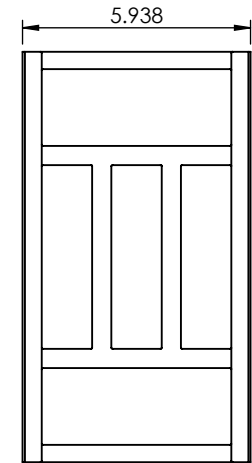
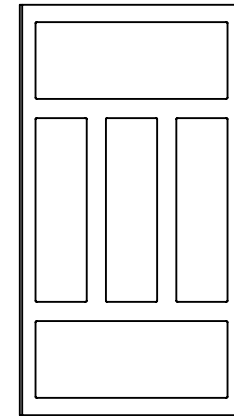
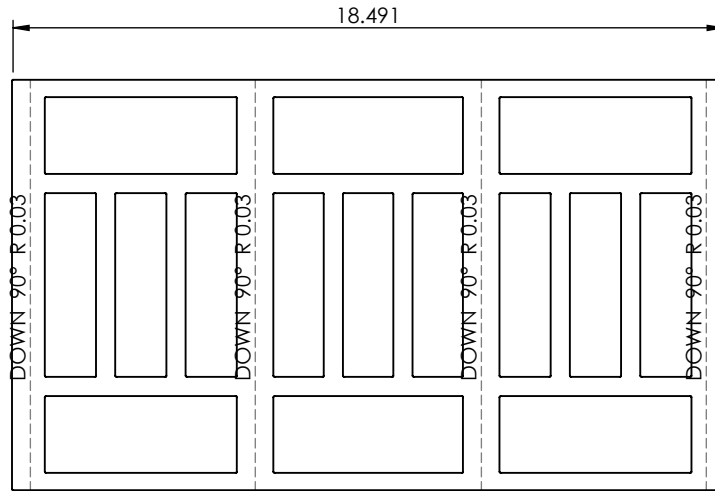
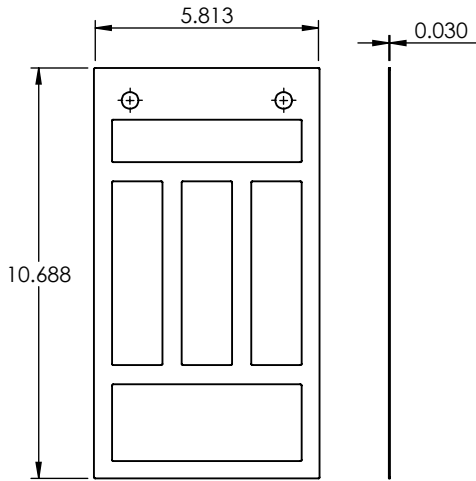
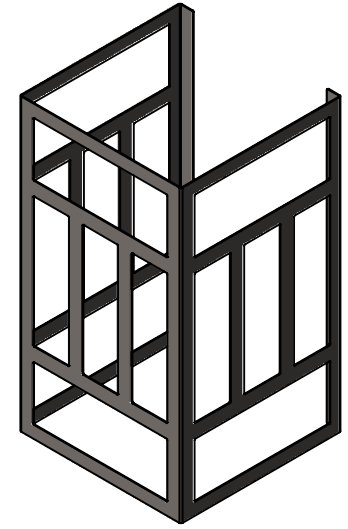
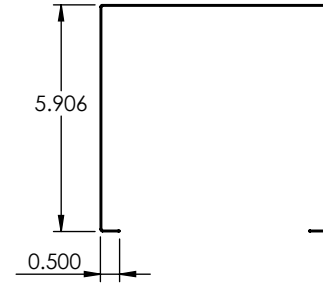
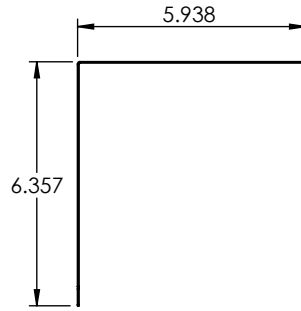
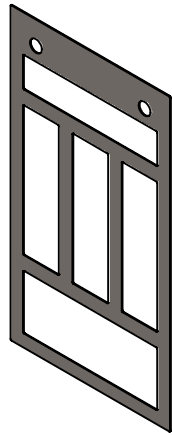

PROPRIETARY AND CONFIDENTIAL
 THE INFORMATION CONTAINED IN THIS DRAWING IS THE SOLE PROPERTY OF <INSERT COMPANY NAME HERE>. ANY REPRODUCTION IN PART OR AS A WHOLE WITHOUT THE WRITTEN PERMISSION OF <INSERT COMPANY NAME HERE> IS PROHIBITED.

		UNLESS OTHERWISE SPECIFIED:		NAME	DATE
		DIMENSIONS ARE IN INCHES	DRAWN		
		TOLERANCES:	CHECKED		
		FRACTIONAL ±	ENG APPR.		
		ANGULAR: MACH ± BEND ±	MFG APPR.		
		TWO PLACE DECIMAL ±	Q.A.		
		THREE PLACE DECIMAL ±	COMMENTS:		
		INTERPRET GEOMETRIC TOLERANCING PER:			
		MATERIAL			
		FINISH			
NEXT ASSY	USED ON				
APPLICATION		DO NOT SCALE DRAWING			

22 GAUGE

TITLE:
 202212L-AB-A-HH-35K

SIZE	DWG. NO.	REV
A		
SCALE: 1:5	WEIGHT:	SHEET 7 OF 9

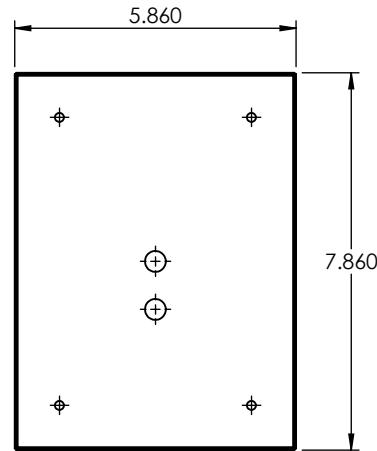
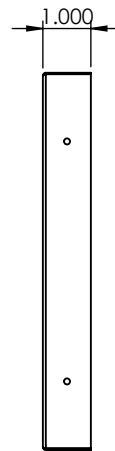
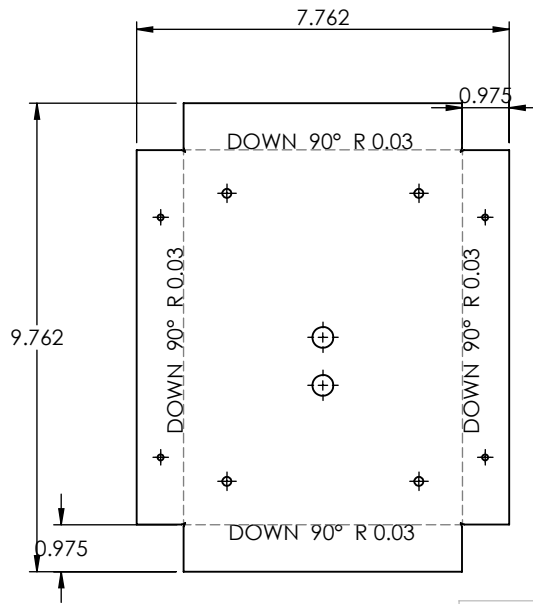
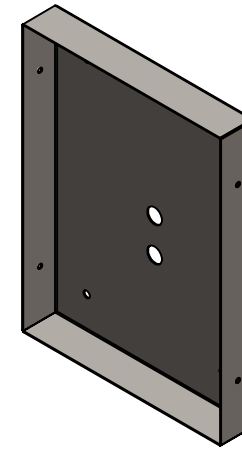
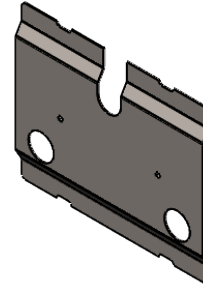
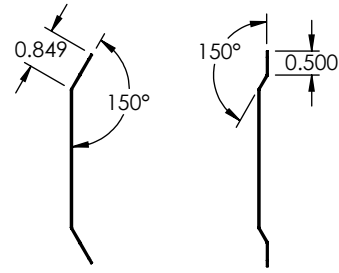
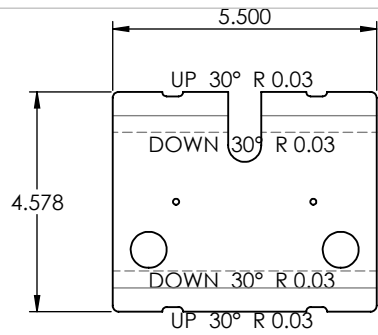

PROPRIETARY AND CONFIDENTIAL
 THE INFORMATION CONTAINED IN THIS DRAWING IS THE SOLE PROPERTY OF <INSERT COMPANY NAME HERE>. ANY REPRODUCTION IN PART OR AS A WHOLE WITHOUT THE WRITTEN PERMISSION OF <INSERT COMPANY NAME HERE> IS PROHIBITED.

		UNLESS OTHERWISE SPECIFIED:		NAME	DATE	22 GAUGE		
		DIMENSIONS ARE IN INCHES TOLERANCES: FRACTIONAL ± ANGULAR: MACH ± BEND ± TWO PLACE DECIMAL ± THREE PLACE DECIMAL ±	DRAWN					TITLE:
		INTERPRET GEOMETRIC TOLERANCING PER:	CHECKED			202212L-AB-A-HH-35K		
		MATERIAL	ENG APPR.			SIZE	DWG. NO.	REV
NEXT ASSY	USED ON	FINISH	MFG APPR.			A		
APPLICATION		DO NOT SCALE DRAWING	Q.A.				SCALE: 1:4	WEIGHT:
			COMMENTS:					