

ITEM NO.	PART NUMBER	DESCRIPTION	QTY.	CUT
1	MDGCY-10LED-9-WET-PE-120V-27K-BACKPLATE	22 GAUGE	1	
2	MDGCY-10LED-9-WET-PE-120V-27K-FIREPLATE	22 GAUGE	1	
3	MDGCY-10LED-9-WET-PE-120V-27K-CONNECTOR BOX TOP	22 GAUGE	1	
4	MDGCY-10LED-9-WET-PE-120V-27K-CONNECTOR BOX BOTTOM	22 GAUGE	1	
5	MDGCY-10LED-9-WET-PE-120V-27K-DIM DRIVER BRACKET	22 GAUGE	1	
6	MDGCY-10LED-9-WET-PE-120V-27K-CONE REFLECTOR	22 GAUGE	1	
7	MDGCY-10LED-9-WET-PE-120V-27K-SPUN CYLINDER	SPUN ALUMINUM 0.080"	1	
8	MDGCY-10LED-9-WET-PE-120V-27K-SPUN DOOR BRACKET	SPUN ALUMINUM 0.0635"	1	
9	MDGCY-10LED-9-WET-PE-120V-27K-SPUN DOOR	SPUN ALUMINUM 0.0635"	1	
10	MDGCY-10LED-9-WET-PE-120V-27K-ACRYLIC	ACRYLIC	1	
11	MDGCY-10LED-9-WET-PE-120V-27K-NIPPLE	3" NIPPLE	2	
12	55MM HEXAGON HEAT SINK	HEAT SINK	1	
13	PHOTO CELL MODEL	SENSOR	1	
14	SMALL NUT	STEEL NUT	8	
15	DS-15W-350C1542010-3001	DRIVER	1	
16	AltaLED_PCN_D1500_110B-10 WATT	LED	1	

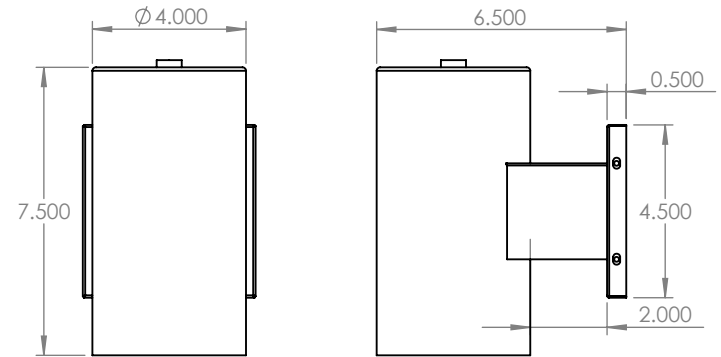

UNLESS OTHERWISE SPECIFIED:		NAME	DATE	TITLE:	
DIMENSIONS ARE IN INCHES		DRAWN		MDGCY-10LED-9-WET-PE-120V-27K	
TOLERANCES:		CHECKED			
FRACTIONAL ± .003		ENG APPR.			
ANGULAR: MACH ± .01 BEND ±		MFG APPR.			
TWO PLACE DECIMAL ±		Q.A.		SIZE	DWG. NO.
THREE PLACE DECIMAL ±.001		COMMENTS:		A	TICKET 25527
INTERPRET GEOMETRIC TOLERANCING PER:				SCALE: 1:5	WEIGHT:
MATERIAL					SHEET 1 OF 12
FINISH					

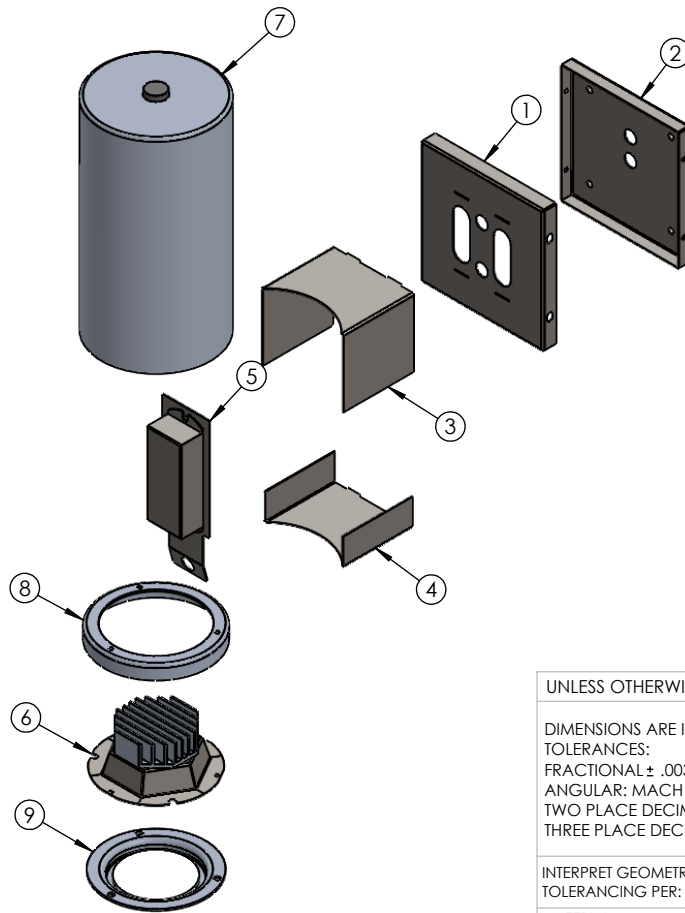
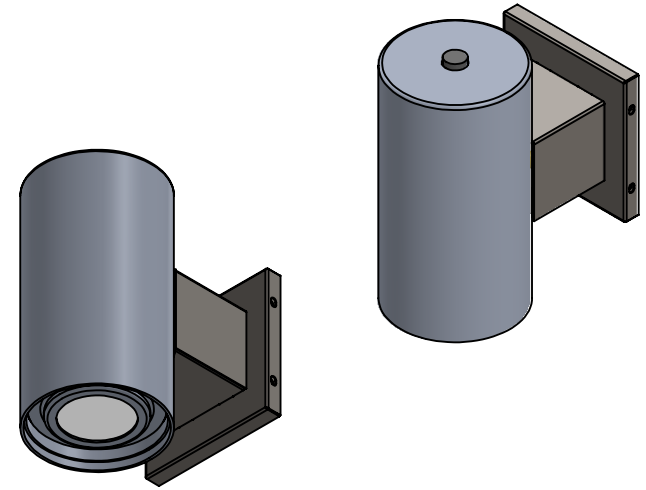

EVERGREEN LIGHTING

ALL BEND RADIUS .030"

APPLICATION

DO NOT SCALE DRAWING

5

4

3

2

1

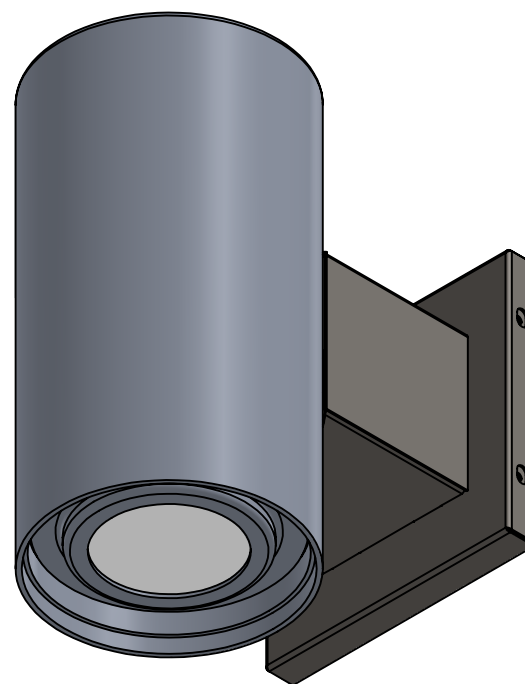
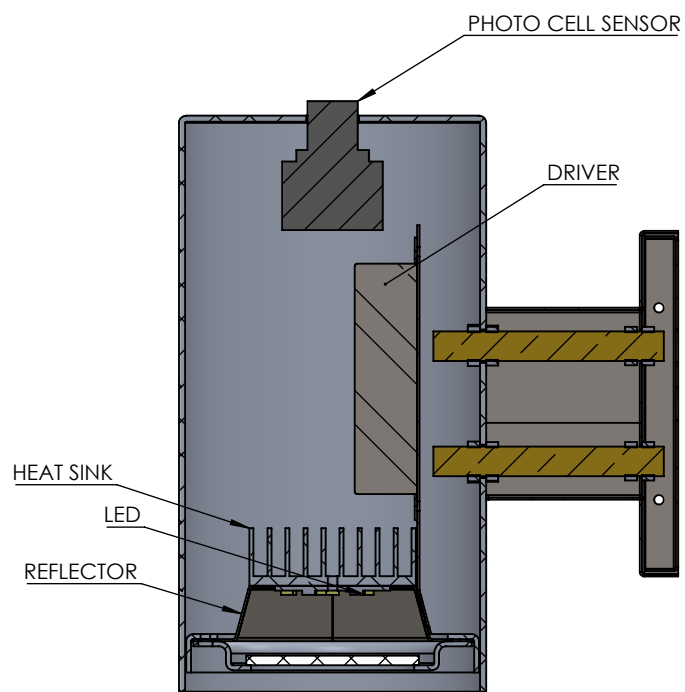
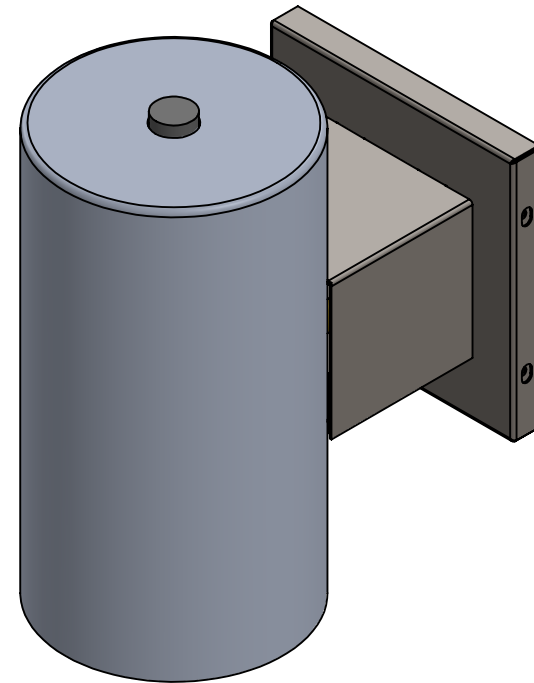
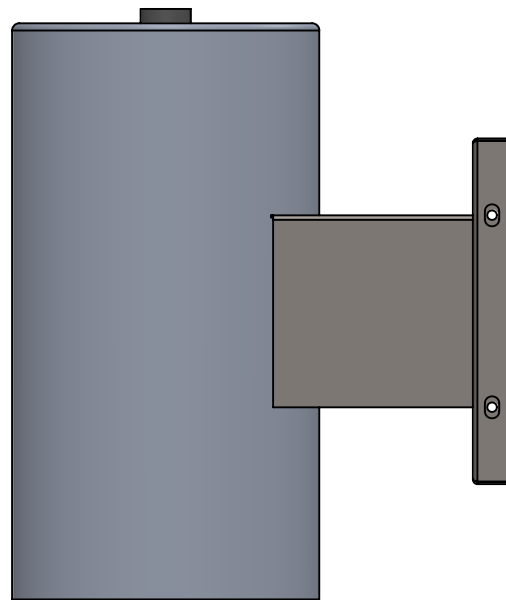
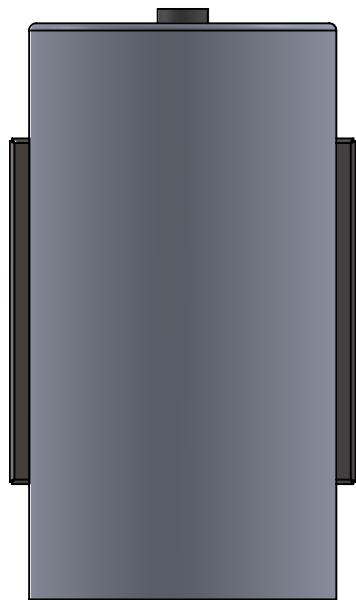

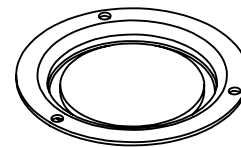
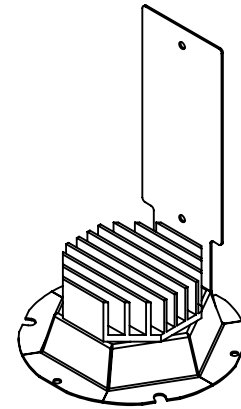
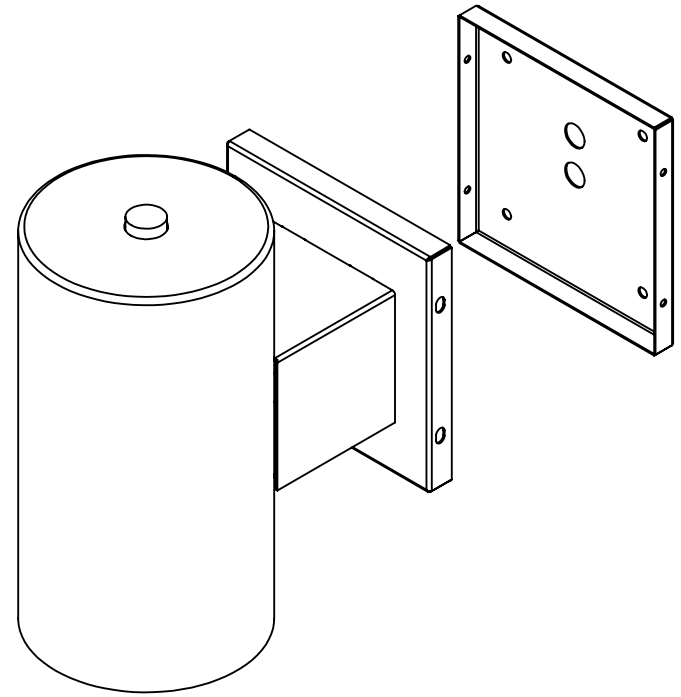
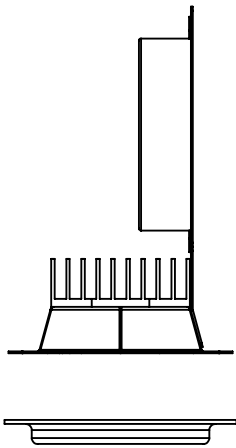
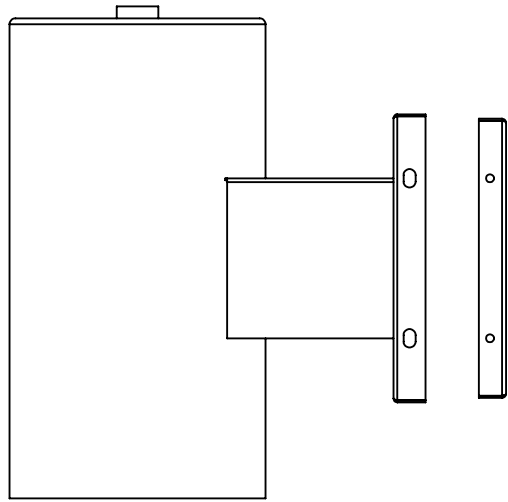

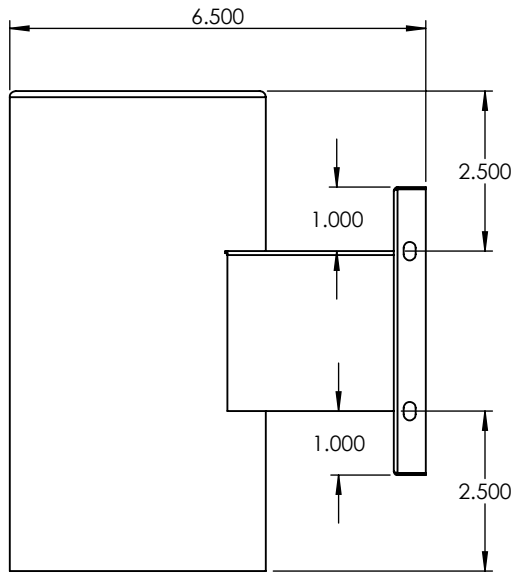
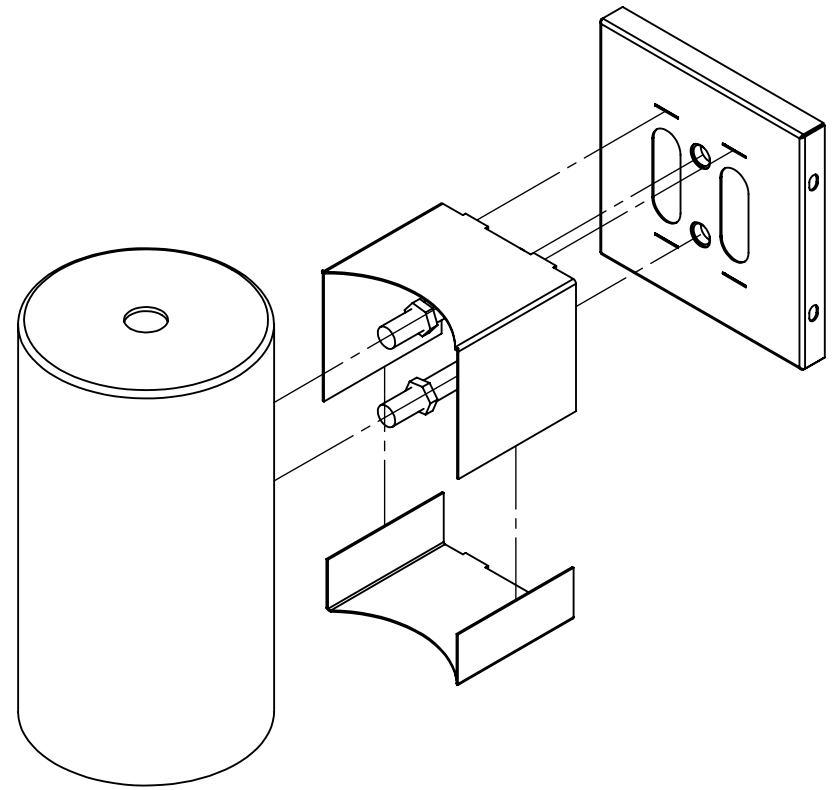
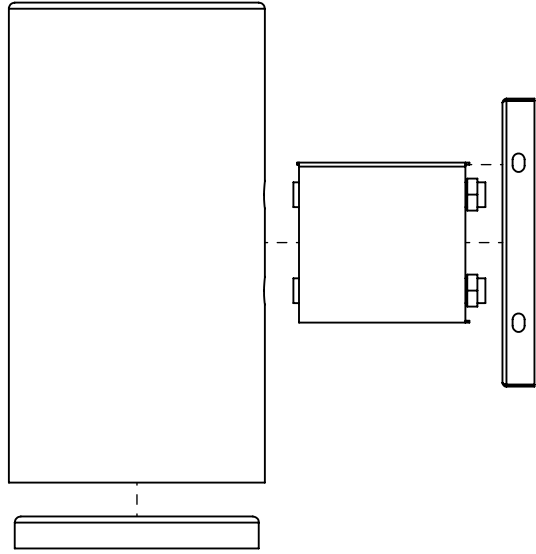

BRACKET REGRESSED 3/4" INTO
CYLINDER BODY

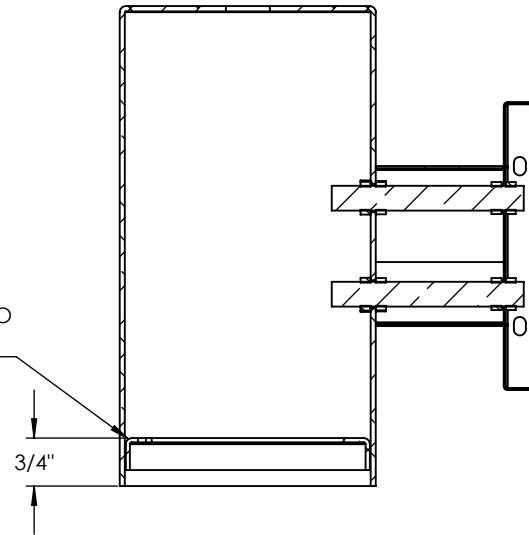

SECTION A-A

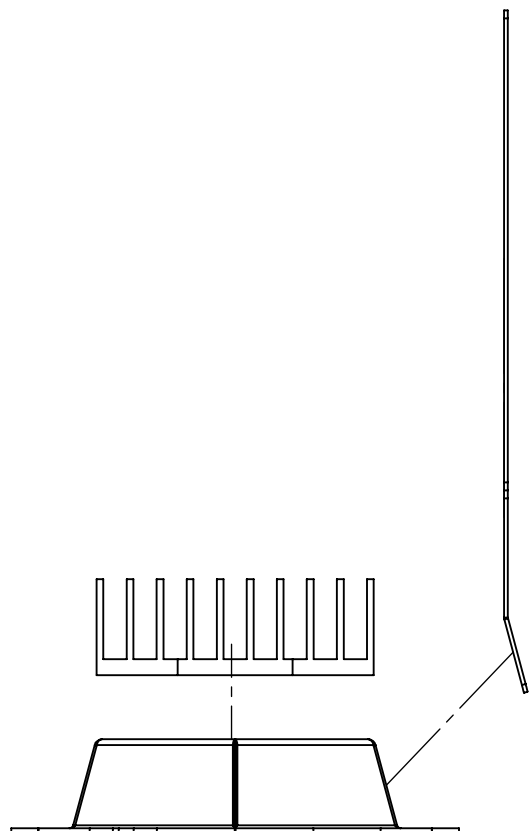

BOLTED TOGETHER

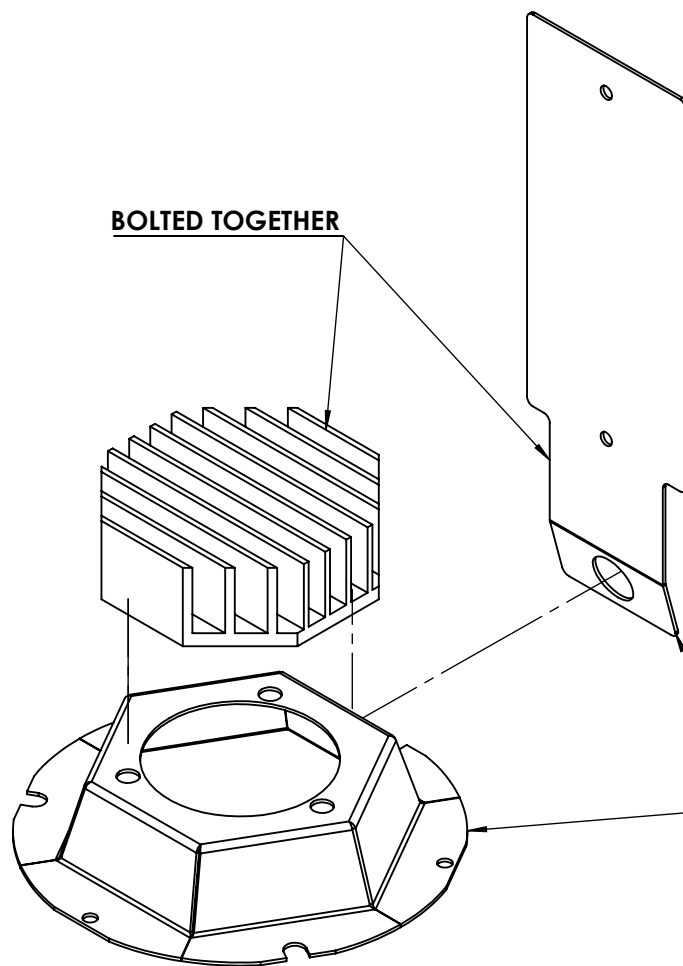

WELDED TOGETHER

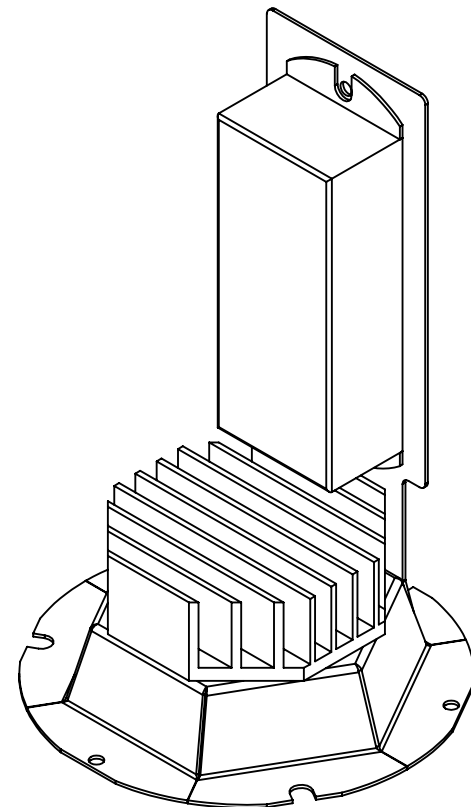

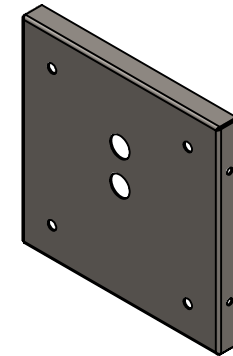
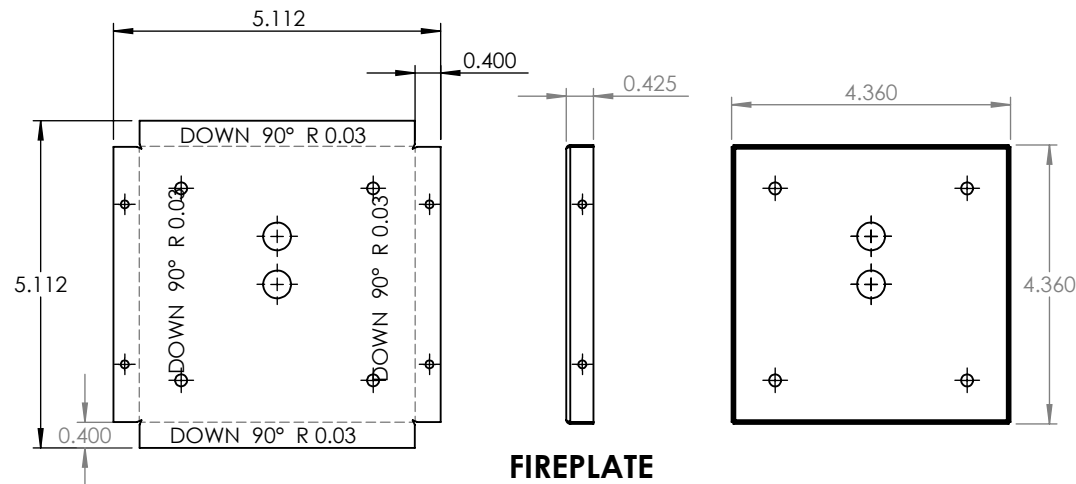
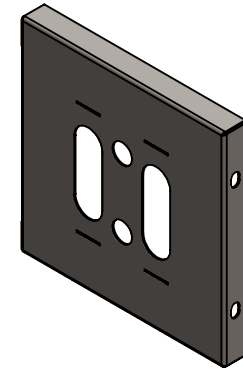
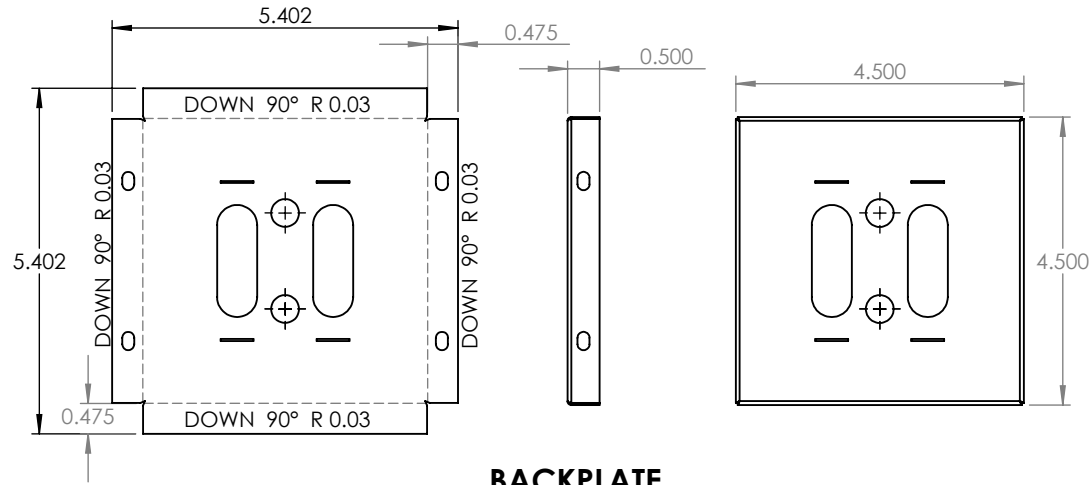

PROPRIETARY AND CONFIDENTIAL
 THE INFORMATION CONTAINED IN THIS DRAWING IS THE SOLE PROPERTY OF <INSERT COMPANY NAME HERE>. ANY REPRODUCTION IN PART OR AS A WHOLE WITHOUT THE WRITTEN PERMISSION OF <INSERT COMPANY NAME HERE> IS PROHIBITED.

		UNLESS OTHERWISE SPECIFIED:	NAME	DATE	22 GAUGE	
		DIMENSIONS ARE IN INCHES	DRAWN		TITLE:	
		TOLERANCES:	CHECKED		MDGCY-10LED-9-WET-PE-120V-27K	
		FRACTIONAL ±	ENG APPR.		SIZE DWG. NO. REV	
		ANGULAR: MACH ± BEND ±	MFG APPR.		SCALE: 1:3 WEIGHT: SHEET 6 OF 12	
		TWO PLACE DECIMAL ±	Q.A.			
		THREE PLACE DECIMAL ±	COMMENTS:			
		INTERPRET GEOMETRIC TOLERANCING PER:				
		MATERIAL				
NEXT ASSY	USED ON	FINISH				
APPLICATION		DO NOT SCALE DRAWING				

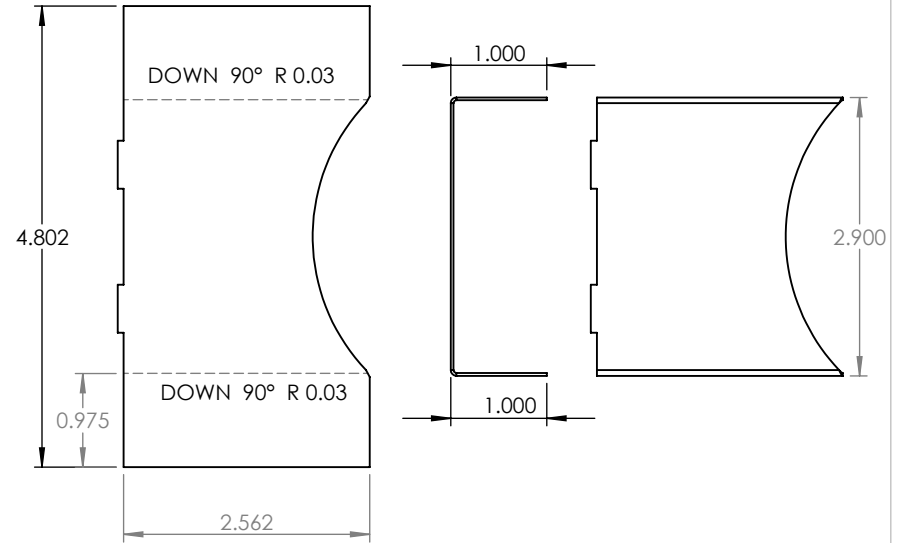
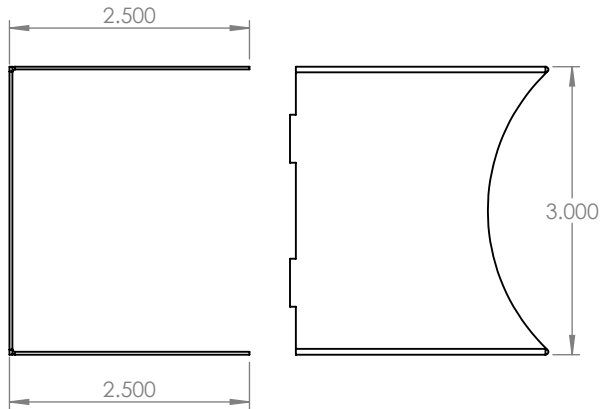
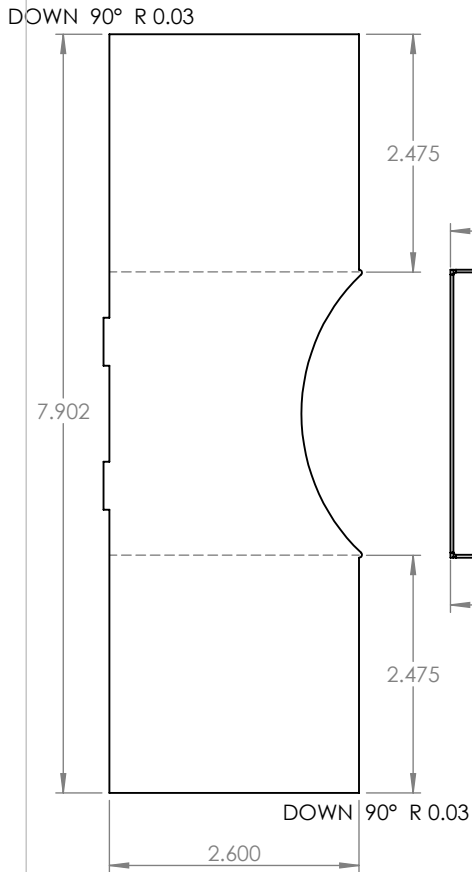
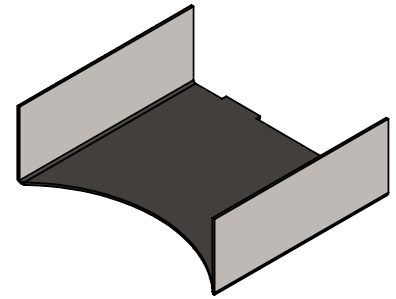
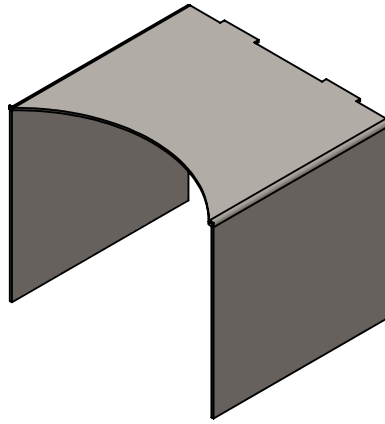

CONNECTOR BOX TOP AND BOTTOM

PROPRIETARY AND CONFIDENTIAL
 THE INFORMATION CONTAINED IN THIS DRAWING IS THE SOLE PROPERTY OF <INSERT COMPANY NAME HERE>. ANY REPRODUCTION IN PART OR AS A WHOLE WITHOUT THE WRITTEN PERMISSION OF <INSERT COMPANY NAME HERE> IS PROHIBITED.

		UNLESS OTHERWISE SPECIFIED:		NAME	DATE
		DIMENSIONS ARE IN INCHES	DRAWN		
		TOLERANCES:	CHECKED		
		FRACTIONAL ±	ENG APPR.		
		ANGULAR: MACH ± BEND ±	MFG APPR.		
		TWO PLACE DECIMAL ±	Q.A.		
		THREE PLACE DECIMAL ±	COMMENTS:		
		INTERPRET GEOMETRIC TOLERANCING PER:			
		MATERIAL			
		FINISH			
NEXT ASSY	USED ON				
APPLICATION		DO NOT SCALE DRAWING			

22 GAUGE		
TITLE:		
MDGCY-10LED-9-WET-PE-120V-27K		
SIZE	DWG. NO.	REV
A		
SCALE: 1:2	WEIGHT:	SHEET 7 OF 12

REFLECTOR

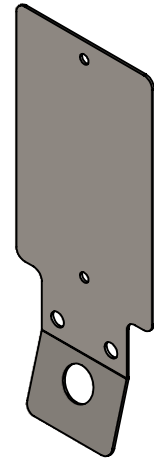
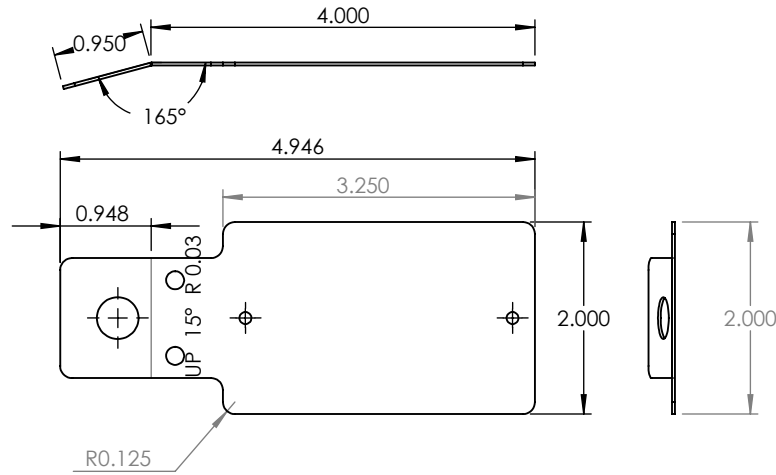
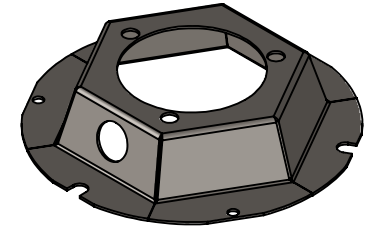
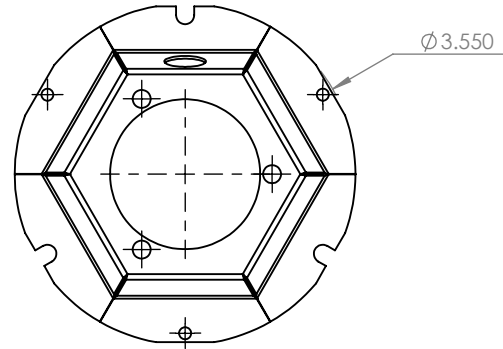
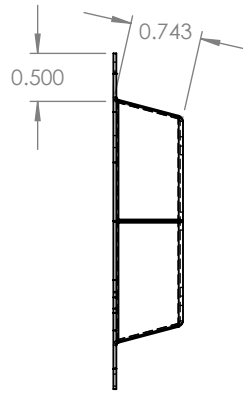
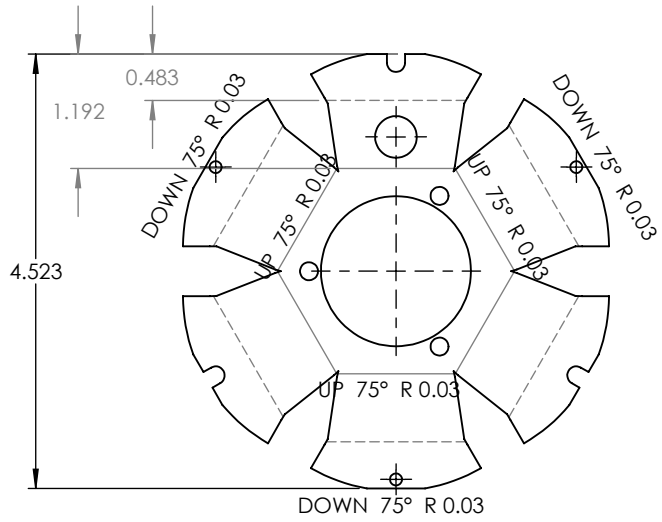

DRIVER PLATE

PROPRIETARY AND CONFIDENTIAL
 THE INFORMATION CONTAINED IN THIS DRAWING IS THE SOLE PROPERTY OF <INSERT COMPANY NAME HERE>. ANY REPRODUCTION IN PART OR AS A WHOLE WITHOUT THE WRITTEN PERMISSION OF <INSERT COMPANY NAME HERE> IS PROHIBITED.

		UNLESS OTHERWISE SPECIFIED:	NAME	DATE	22 GAUGE	
		DIMENSIONS ARE IN INCHES	DRAWN		TITLE:	
		TOLERANCES:	CHECKED		MDGCY-10LED-9-WET-PE-120V-27K	
		FRACTIONAL ±	ENG APPR.		SIZE DWG. NO. REV	
		ANGULAR: MACH ± BEND ±	MFG APPR.		A	
		TWO PLACE DECIMAL ±	Q.A.		SCALE: 1:2 WEIGHT: SHEET 8 OF 12	
		THREE PLACE DECIMAL ±	COMMENTS:			
NEXT ASSY	USED ON	INTERPRET GEOMETRIC TOLERANCING PER:				
APPLICATION		MATERIAL				
		FINISH				
		DO NOT SCALE DRAWING				

ITEM NO.	PART NUMBER	DESCRIPTION	QTY.
1	MDGKY-10LED-9-WET-PE-120V-27K-SPUN CYLINDER	SPUN ALUMINUM 0.080"	1

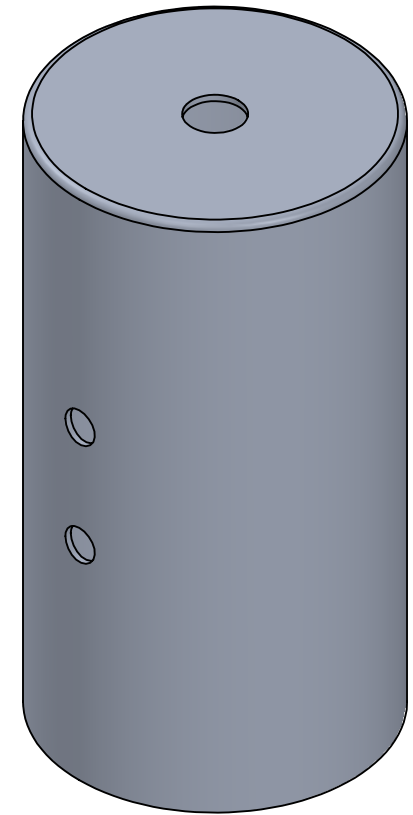
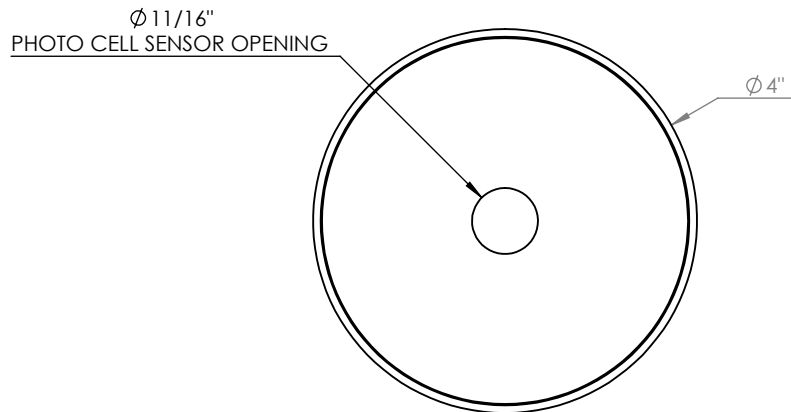
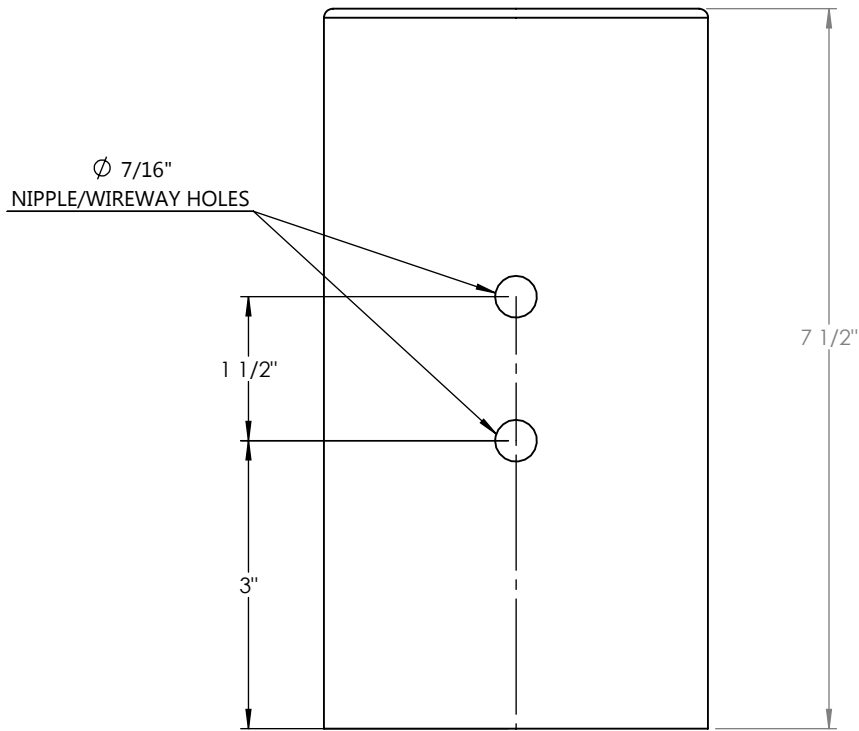

CYLINDER

PROPRIETARY AND CONFIDENTIAL
 THE INFORMATION CONTAINED IN THIS DRAWING IS THE SOLE PROPERTY OF <INSERT COMPANY NAME HERE>. ANY REPRODUCTION IN PART OR AS A WHOLE WITHOUT THE WRITTEN PERMISSION OF <INSERT COMPANY NAME HERE> IS PROHIBITED.

NEXT ASSY	USED ON
APPLICATION	
DO NOT SCALE DRAWING	

UNLESS OTHERWISE SPECIFIED:				NAME	DATE	SPUN ALUMINUM 0.080"	
DIMENSIONS ARE IN INCHES				DRAWN		TITLE:	
TOLERANCES:				CHECKED		MDGKY-10LED-9-WET-PE-120V-27K	
FRACTIONAL \pm				ENG APPR.		SIZE	DWG. NO.
ANGULAR: MACH \pm BEND \pm				MFG APPR.		A	REV
TWO PLACE DECIMAL \pm				Q.A.		SCALE: 1:2	WEIGHT:
THREE PLACE DECIMAL \pm				COMMENTS:			SHEET 9 OF 12
INTERPRET GEOMETRIC TOLERANCING PER:							
MATERIAL							
FINISH							

ITEM NO.	PART NUMBER	DESCRIPTION	QTY.
1	MDGKY-10LED-9-WET-PE-120V-27K-SPUN DOOR	SPUN ALUMINUM 0.0635"	1

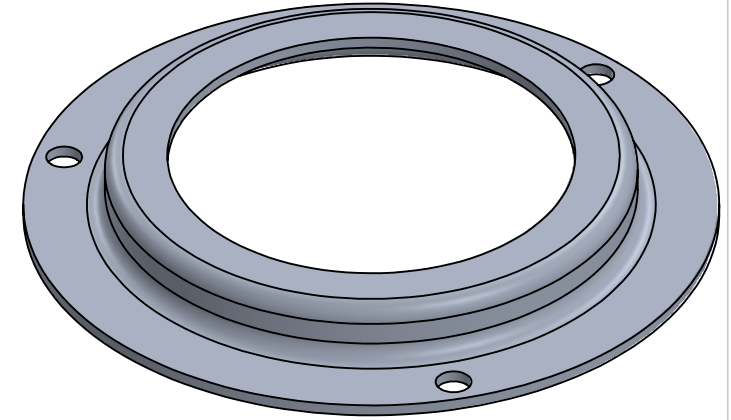
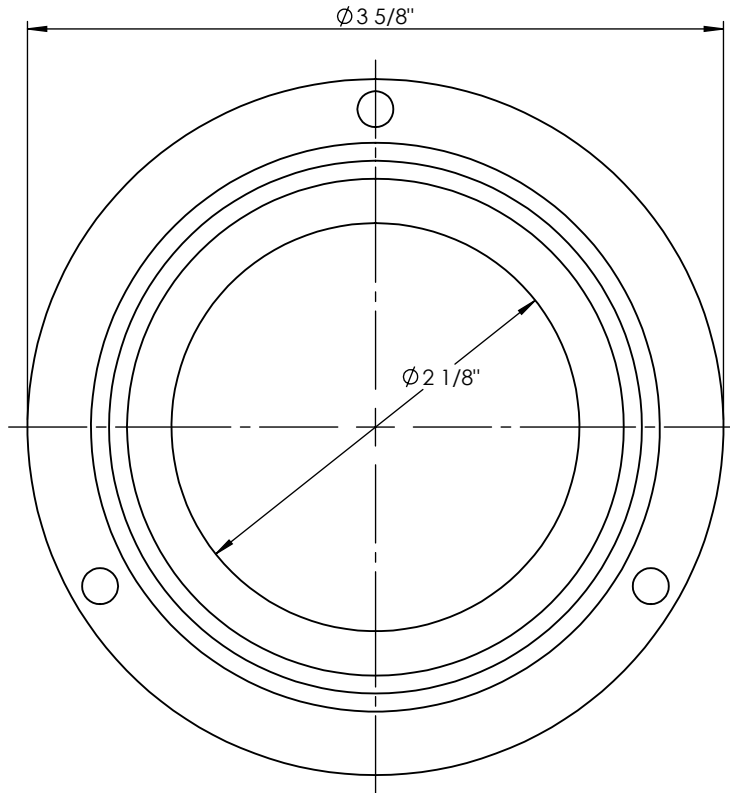
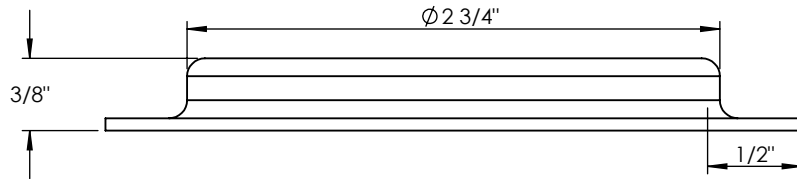

PROPRIETARY AND CONFIDENTIAL
 THE INFORMATION CONTAINED IN THIS DRAWING IS THE SOLE PROPERTY OF <INSERT COMPANY NAME HERE>. ANY REPRODUCTION IN PART OR AS A WHOLE WITHOUT THE WRITTEN PERMISSION OF <INSERT COMPANY NAME HERE> IS PROHIBITED.

		UNLESS OTHERWISE SPECIFIED:		NAME	DATE
		DIMENSIONS ARE IN INCHES	DRAWN		
		TOLERANCES:	CHECKED		
		FRACTIONAL ±	ENG APPR.		
		ANGULAR: MACH ± BEND ±	MFG APPR.		
		TWO PLACE DECIMAL ±	Q.A.		
		THREE PLACE DECIMAL ±	COMMENTS:		
		INTERPRET GEOMETRIC TOLERANCING PER:			
		MATERIAL			
NEXT ASSY	USED ON	FINISH			
APPLICATION		DO NOT SCALE DRAWING			

SPUN ALUMINUM 0.0635"		
TITLE:		
MDGKY-10LED-9-WET-PE-120V-27K		
SIZE	DWG. NO.	REV
A		
SCALE: 1:1	WEIGHT:	SHEET 10 OF 12

ITEM NO.	PART NUMBER	DESCRIPTION	QTY.
1	MDGCY-10LED-9-WET-PE-120V-27K-SPUN DOOR BRACKET	SPUN ALUMINUM 0.0635"	1

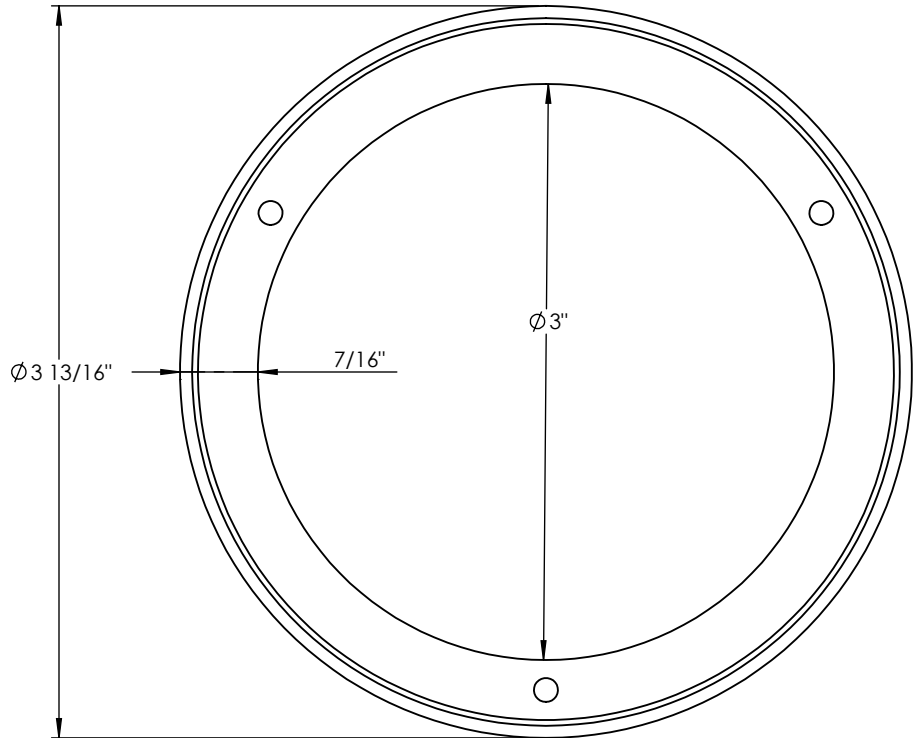
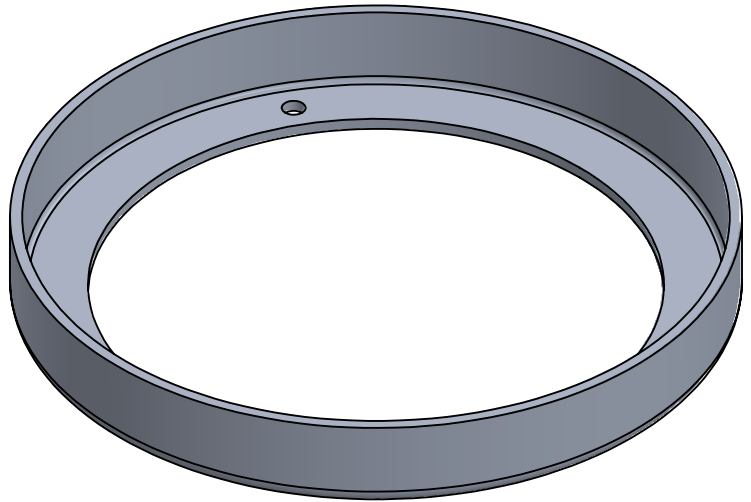
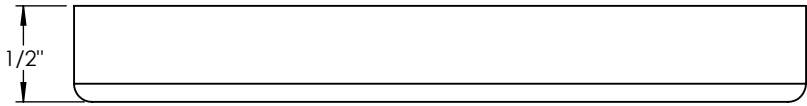

PROPRIETARY AND CONFIDENTIAL
 THE INFORMATION CONTAINED IN THIS DRAWING IS THE SOLE PROPERTY OF <INSERT COMPANY NAME HERE>. ANY REPRODUCTION IN PART OR AS A WHOLE WITHOUT THE WRITTEN PERMISSION OF <INSERT COMPANY NAME HERE> IS PROHIBITED.

		UNLESS OTHERWISE SPECIFIED:	NAME	DATE
		DIMENSIONS ARE IN INCHES TOLERANCES: FRACTIONAL ± ANGULAR: MACH ± BEND ± TWO PLACE DECIMAL ± THREE PLACE DECIMAL ±	DRAWN	
		INTERPRET GEOMETRIC TOLERANCING PER:	CHECKED	
		MATERIAL	ENG APPR.	
		FINISH	MFG APPR.	
NEXT ASSY	USED ON		Q.A.	
			COMMENTS:	
APPLICATION	DO NOT SCALE DRAWING			

SPUN ALUMINUM 0.0635"		
TITLE:		
MDGCY-10LED-9-WET-PE-120V-27K		
SIZE	DWG. NO.	REV
A		
SCALE: 1:1	WEIGHT:	SHEET 11 OF 12

5

4

3

2

1

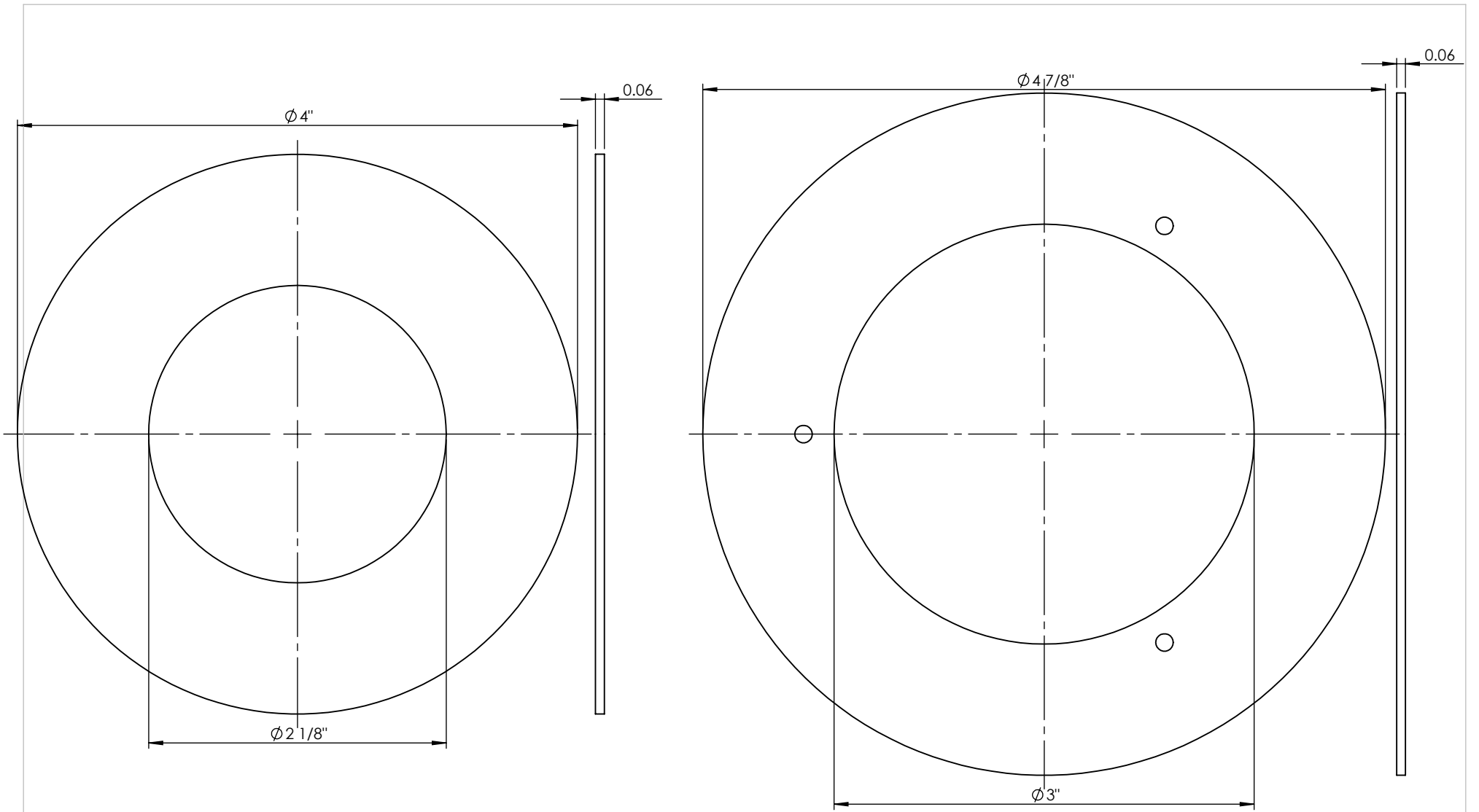

PROPRIETARY AND CONFIDENTIAL
 THE INFORMATION CONTAINED IN THIS DRAWING IS THE SOLE PROPERTY OF <INSERT COMPANY NAME HERE>. ANY REPRODUCTION IN PART OR AS A WHOLE WITHOUT THE WRITTEN PERMISSION OF <INSERT COMPANY NAME HERE> IS PROHIBITED.

		UNLESS OTHERWISE SPECIFIED:		NAME	DATE
		DIMENSIONS ARE IN INCHES	DRAWN		
		TOLERANCES:	CHECKED		
		FRACTIONAL ±	ENG APPR.		
		ANGULAR: MACH ± BEND ±	MFG APPR.		
		TWO PLACE DECIMAL ±	Q.A.		
		THREE PLACE DECIMAL ±	COMMENTS:		
		INTERPRET GEOMETRIC TOLERANCING PER:			
		MATERIAL			
		FINISH			
NEXT ASSY	USED ON				
APPLICATION		DO NOT SCALE DRAWING			

TITLE:		
MDGCY-10LED-9-WET-PE-120V-27K		
SIZE	DWG. NO.	REV
A		
SCALE: 1:1	WEIGHT:	SHEET 12 OF 12