

ITEM NO.	PART NUMBER	DESCRIPTION	QTY.	CUT
1	HS-W-18X6-UD-30W-MBK-WF-41K-BACKPLATE	22 GAUGE	1	
2	HS-W-18X6-UD-30W-MBK-WF-41K-FIREPLATE	22 GAUGE	1	
3	HS-W-18X6-UD-30W-MBK-WF-41K-ROLLED FRAME	22 GAUGE	1	
4	HS-W-10-6LED-MG-A-ST-277V-41K-LENS BOTTOM	22 GAUGE	2	
5	HS-W-18X6-UD-30W-MBK-WF-41K-LED BRACKET	22 GAUGE	1	
6	HS-W-18X6-UD-30W-MBK-WF-41K-ACRYLIC	ACRYLIC	2	
7	Espen VEL19070MVH-1	DRIVER	2	
8	AltaiLED_PN1004RevD	LED	4	

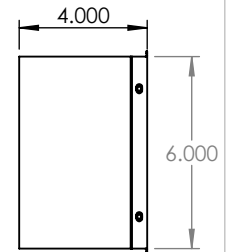
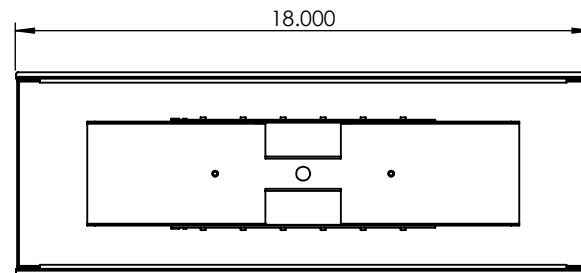
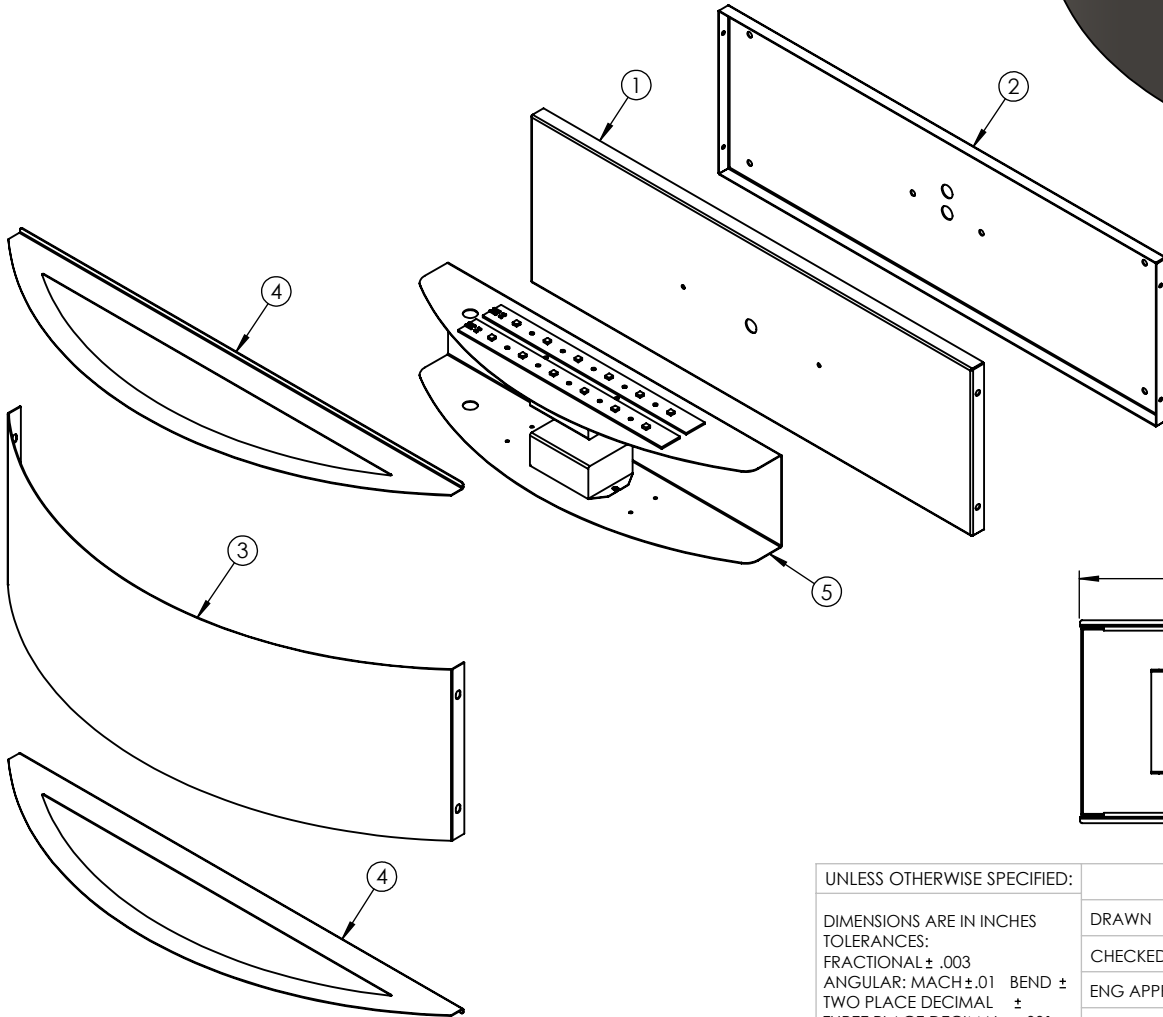
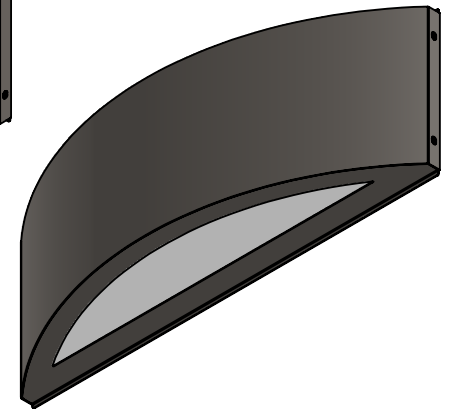
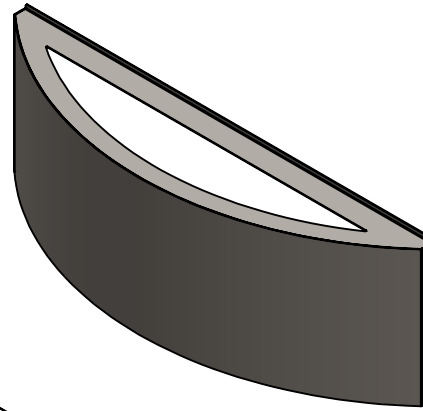

UNLESS OTHERWISE SPECIFIED:

DIMENSIONS ARE IN INCHES  
 TOLERANCES:  
 FRACTIONAL ± .003  
 ANGULAR: MACH ± .01 BEND ±  
 TWO PLACE DECIMAL ±  
 THREE PLACE DECIMAL ±.001

INTERPRET GEOMETRIC  
 TOLERANCING PER:  
 MATERIAL

FINISH

	NAME	DATE
DRAWN		
CHECKED		
ENG APPR.		
MFG APPR.		
Q.A.		

COMMENTS:

TITLE:

HS-W-18X6-UD-30W-MBK-WF-41K

SIZE DWG. NO. REV  
**A** TICKET 25535

SCALE: 1:6 WEIGHT: SHEET 1 OF 6



**EVERGREEN LIGHTING**

ALL BEND RADIUS .030"

APPLICATION

DO NOT SCALE DRAWING

5

4

3

2

1

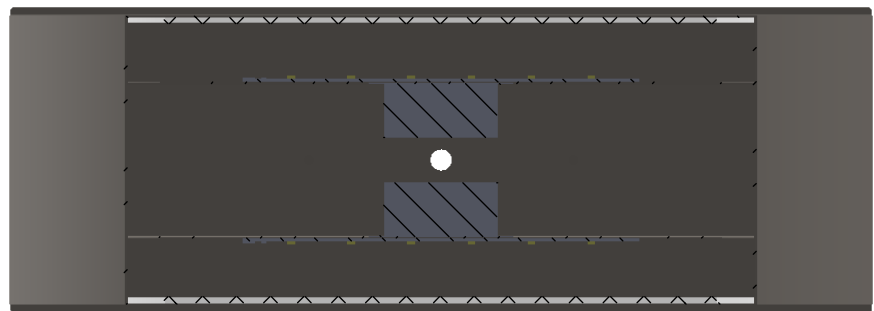
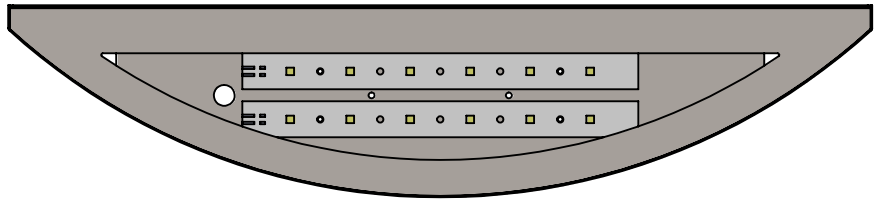

SECTION A-A

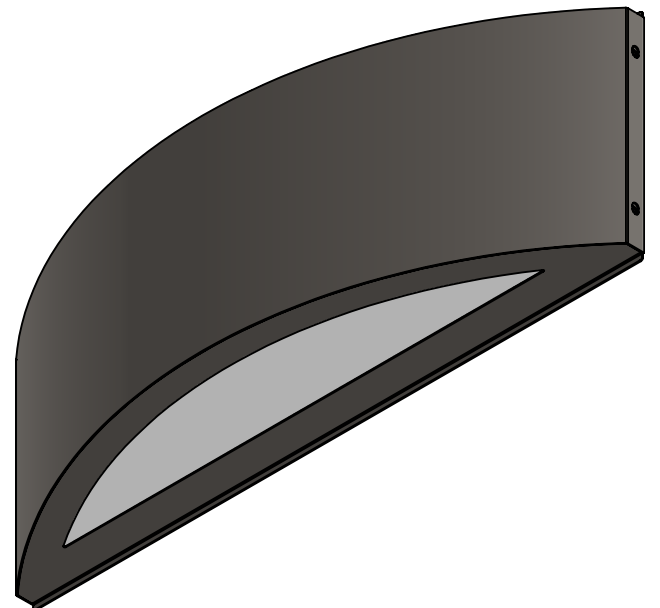
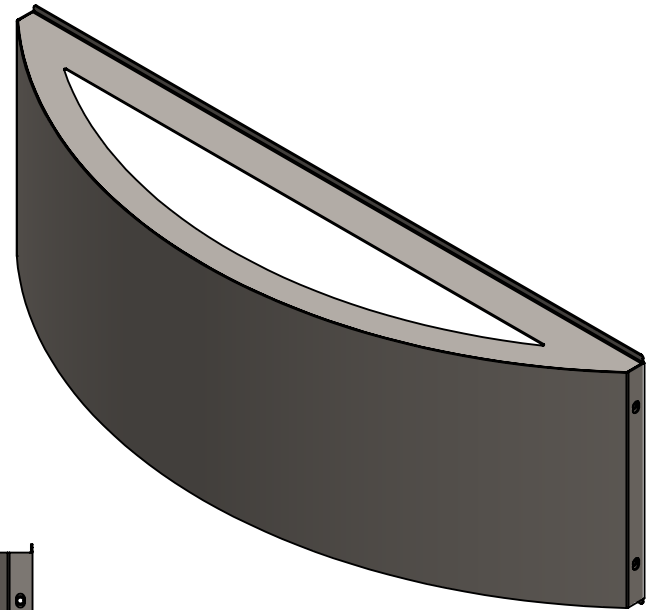
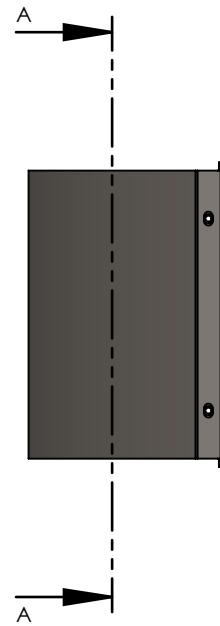

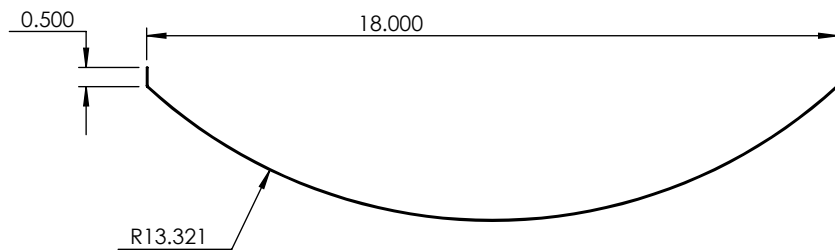
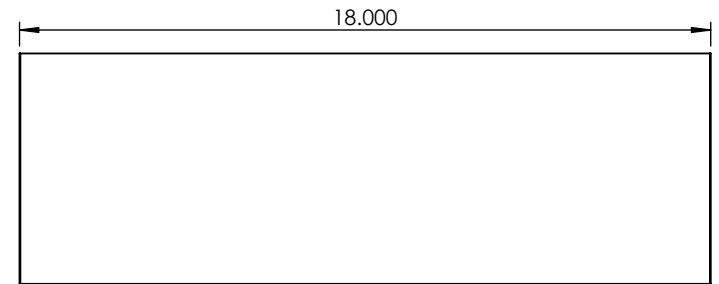
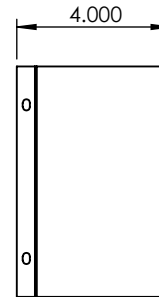
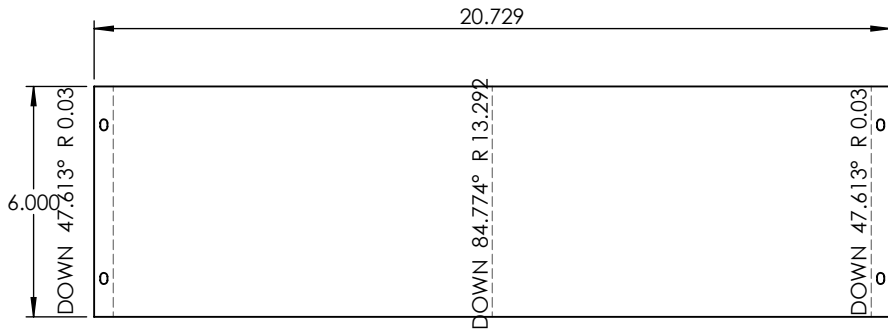
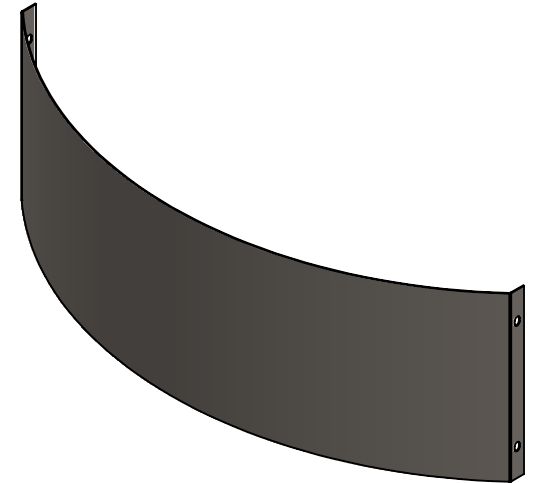
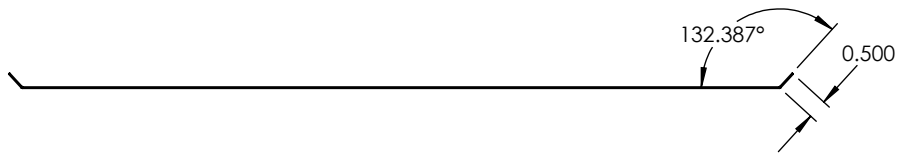

UNLESS OTHERWISE SPECIFIED:		NAME	DATE	22 GAUGE	
DIMENSIONS ARE IN INCHES TOLERANCES: FRACTIONAL ± ANGULAR: MACH ± BEND ± TWO PLACE DECIMAL ± THREE PLACE DECIMAL ±		DRAWN		TITLE:	
		CHECKED		HS-W-18X6-UD-30W-MBK-WF-41K	
		ENG APPR.		SIZE DWG. NO. REV	
		MFG APPR.		SCALE: 1:5 WEIGHT: SHEET 3 OF 6	
		Q.A.			
		COMMENTS:			
INTERPRET GEOMETRIC TOLERANCING PER:					
MATERIAL					
FINISH					
NEXT ASSY		USED ON			
APPLICATION		DO NOT SCALE DRAWING			

**PROPRIETARY AND CONFIDENTIAL**  
THE INFORMATION CONTAINED IN THIS DRAWING IS THE SOLE PROPERTY OF <INSERT COMPANY NAME HERE>. ANY REPRODUCTION IN PART OR AS A WHOLE WITHOUT THE WRITTEN PERMISSION OF <INSERT COMPANY NAME HERE> IS PROHIBITED.

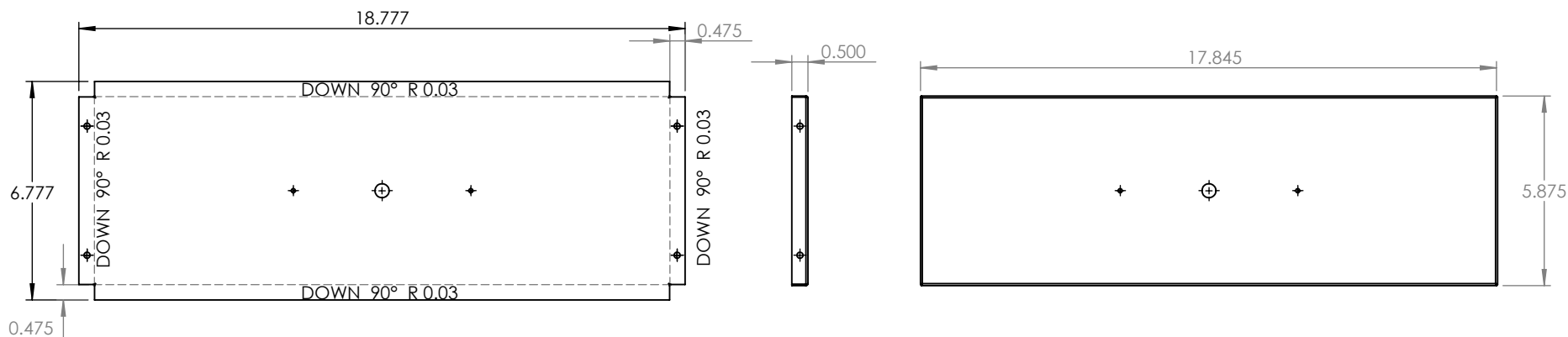
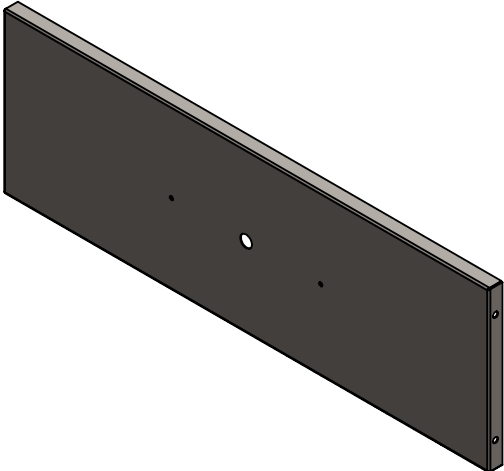

**PROPRIETARY AND CONFIDENTIAL**  
 THE INFORMATION CONTAINED IN THIS DRAWING IS THE SOLE PROPERTY OF <INSERT COMPANY NAME HERE>. ANY REPRODUCTION IN PART OR AS A WHOLE WITHOUT THE WRITTEN PERMISSION OF <INSERT COMPANY NAME HERE> IS PROHIBITED.

		UNLESS OTHERWISE SPECIFIED:	NAME	DATE
		DIMENSIONS ARE IN INCHES	DRAWN	
		TOLERANCES:	CHECKED	
		FRACTIONAL ±	ENG APPR.	
		ANGULAR: MACH ± BEND ±	MFG APPR.	
		TWO PLACE DECIMAL ±	Q.A.	
		THREE PLACE DECIMAL ±	COMMENTS:	
		INTERPRET GEOMETRIC TOLERANCING PER:		
		MATERIAL		
NEXT ASSY	USED ON	FINISH		
APPLICATION		DO NOT SCALE DRAWING		

22 GAUGE		
TITLE:		
HS-W-18X6-UD-30W-MBK-WF-41K		
SIZE	DWG. NO.	REV
<b>A</b>		
SCALE: 1:5	WEIGHT:	SHEET 4 OF 6

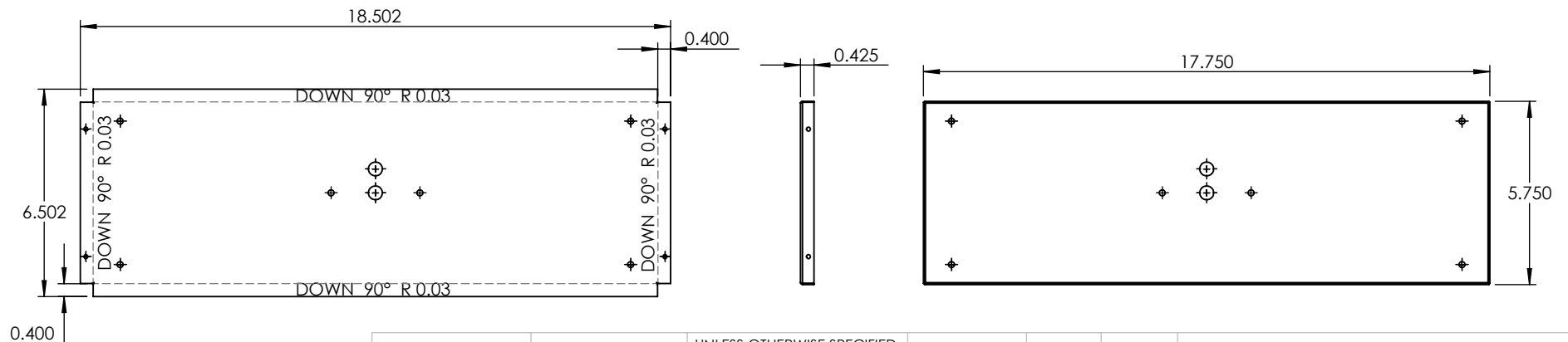
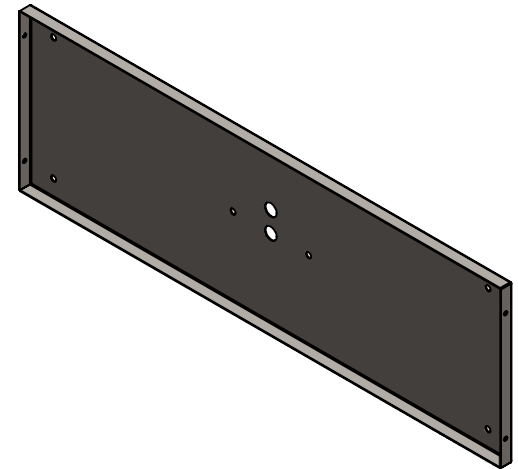

**PROPRIETARY AND CONFIDENTIAL**  
 THE INFORMATION CONTAINED IN THIS DRAWING IS THE SOLE PROPERTY OF <INSERT COMPANY NAME HERE>. ANY REPRODUCTION IN PART OR AS A WHOLE WITHOUT THE WRITTEN PERMISSION OF <INSERT COMPANY NAME HERE> IS PROHIBITED.

		UNLESS OTHERWISE SPECIFIED:	NAME	DATE
		DIMENSIONS ARE IN INCHES	DRAWN	
		TOLERANCES:	CHECKED	
		FRACTIONAL ±	ENG APPR.	
		ANGULAR: MACH ± BEND ±	MFG APPR.	
		TWO PLACE DECIMAL ±	Q.A.	
		THREE PLACE DECIMAL ±	COMMENTS:	
		INTERPRET GEOMETRIC TOLERANCING PER:		
		MATERIAL		
		FINISH		
NEXT ASSY	USED ON			
APPLICATION		DO NOT SCALE DRAWING		

22 GAUGE		
TITLE:		
HS-W-18X6-UD-30W-MBK-WF-41K		
SIZE	DWG. NO.	REV
<b>A</b>		
SCALE: 1:5	WEIGHT:	SHEET 5 OF 6

**TOP AND BOTTOM CAPS ARE TO BE WELDED INSIDE SHELL FRAME, FLUSH WITH SIDES**

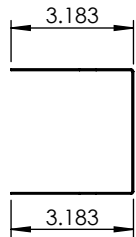
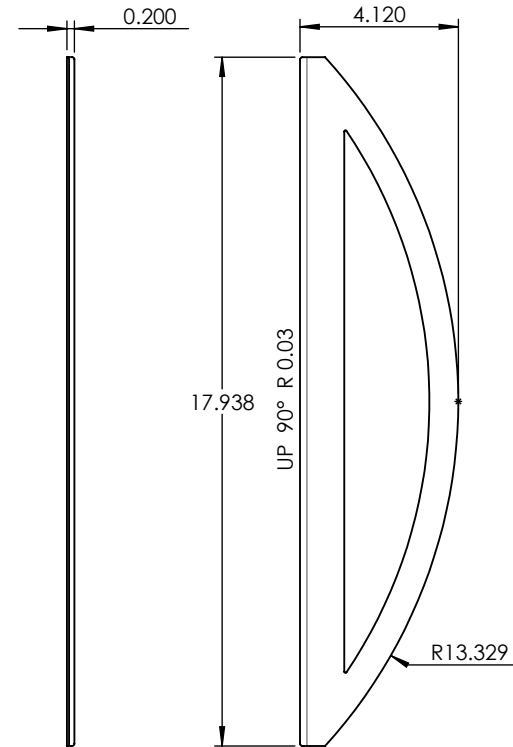
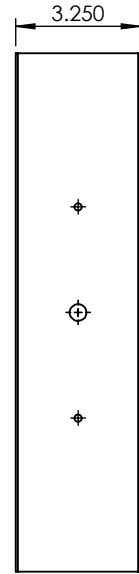
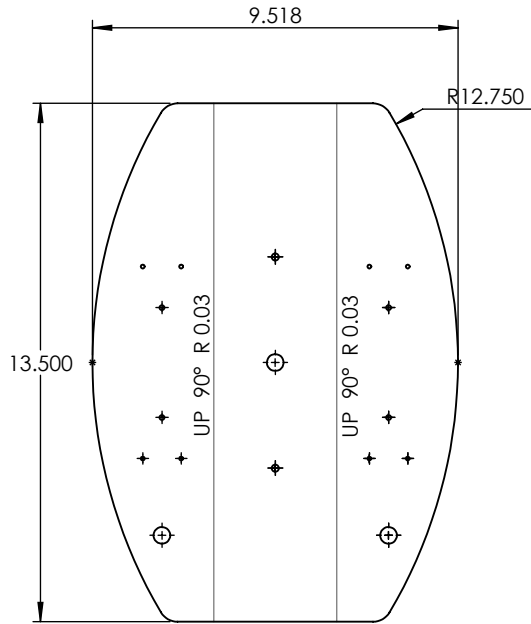
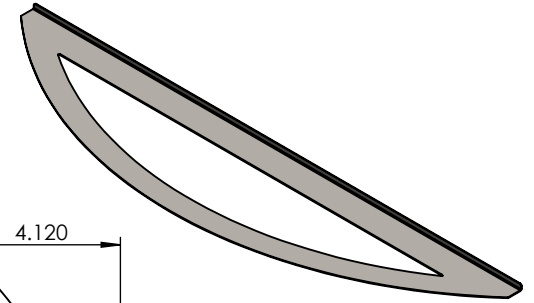
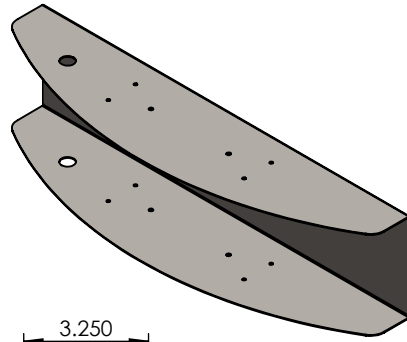

**PROPRIETARY AND CONFIDENTIAL**  
 THE INFORMATION CONTAINED IN THIS DRAWING IS THE SOLE PROPERTY OF <INSERT COMPANY NAME HERE>. ANY REPRODUCTION IN PART OR AS A WHOLE WITHOUT THE WRITTEN PERMISSION OF <INSERT COMPANY NAME HERE> IS PROHIBITED.

		UNLESS OTHERWISE SPECIFIED:	NAME	DATE	22 GAUGE	
		DIMENSIONS ARE IN INCHES	DRAWN		TITLE:	
		TOLERANCES:	CHECKED		HS-W-18X6-UD-30W-MBK-WF-41K	
		FRACTIONAL ±	ENG APPR.		SIZE	DWG. NO.
		ANGULAR: MACH ± BEND ±	MFG APPR.		<b>A</b>	REV
		TWO PLACE DECIMAL ±	Q.A.		SCALE: 1:5	WEIGHT:
		THREE PLACE DECIMAL ±	COMMENTS:			SHEET 6 OF 6
		INTERPRET GEOMETRIC TOLERANCING PER:				
		MATERIAL				
NEXT ASSY	USED ON	FINISH				
APPLICATION		DO NOT SCALE DRAWING				