

ITEM NO.	PART NUMBER	DESCRIPTION	QTY.	CUT
1	BX-DN-PLT31"-36W-TBK-CFA-WET-30K-TOP FRAME	18 GAUGE	1	
2	BX-DN-PLT31"-36W-TBK-CFA-WET-30K-BOTTOM FRAME	18 GAUGE	1	
3	BX-DN-PLT31"-36W-TBK-CFA-WET-30K-FRAME PLATE	22 GAUGE	1	
4	BX-DN-PLT31"-36W-TBK-CFA-WET-30K-FRAME TAB	22 GAUGE	4	
5	BX-DN-PLT31"-36W-TBK-CFA-WET-30K-BACKPLATE	22 GAUGE	1	
6	BX-DN-PLT31"-36W-TBK-CFA-WET-30K-FIREPLATE	22 GAUGE	1	
7	BX-DN-PLT31"-36W-TBK-CFA-WET-30K-LED BRACKET	ALUMINUM 0.0635"	1	
8	BX-DN-PLT31"-36W-TBK-CFA-WET-30K-ACRYLIC	ACRYLIC	1	
9	55MM HEXAGON HEAT SINK	HEAT SINK	2	
10	AltalED PCN D1500 110B-10 WATT	LED	3	
11	BX-DN-PLT31"-36W-TBK-CFA-WET-30K-HEAT SINK	ALUMINUM 0.500" PLATE	1	
12	EspenTECH_120277V_SKU808076	DRIVER	3	

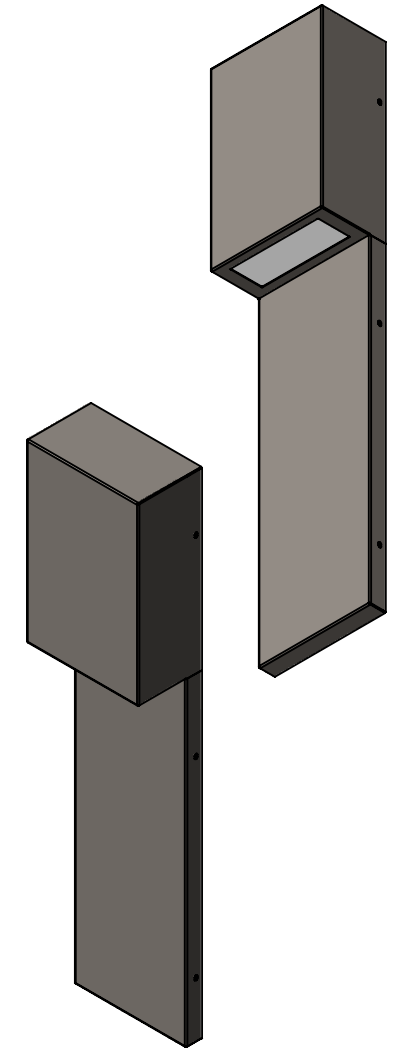
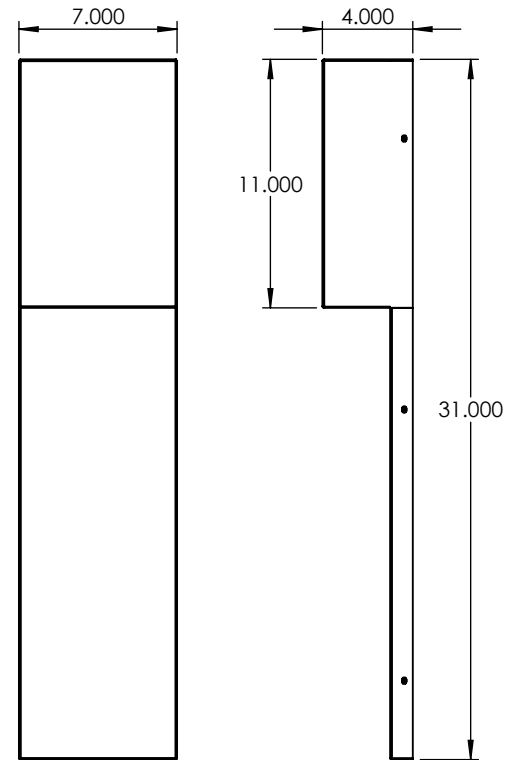
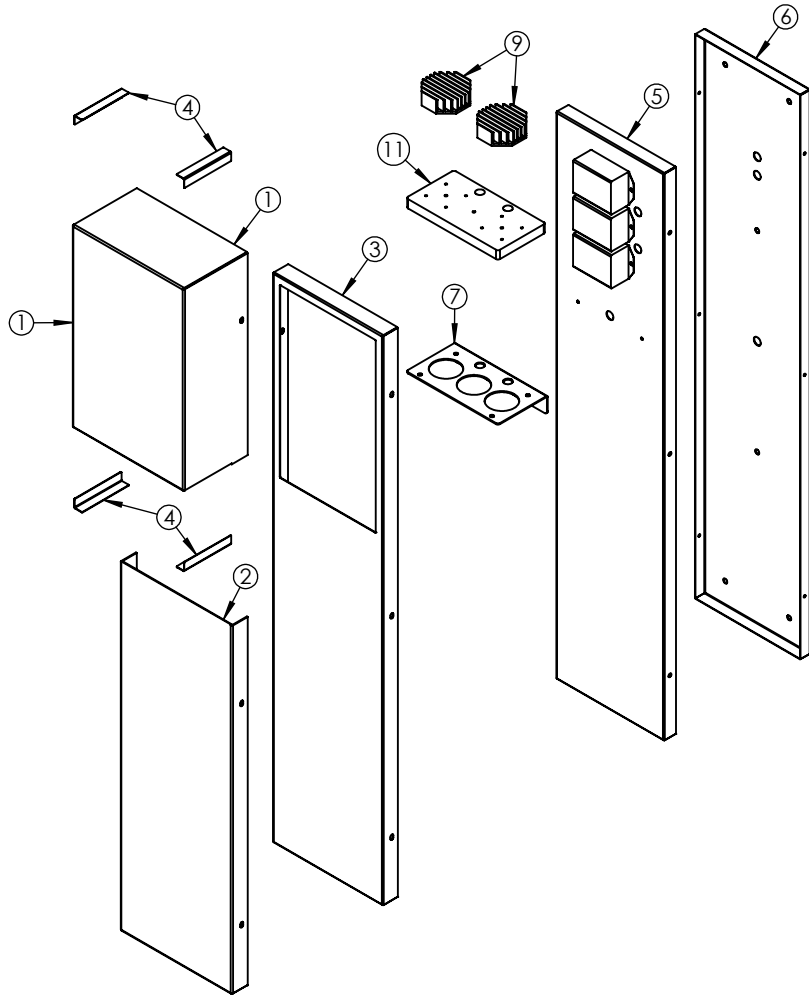

**EVERGREEN LIGHTING**

ALL BEND RADIUS .030"

APPLICATION

DO NOT SCALE DRAWING

UNLESS OTHERWISE SPECIFIED:

DIMENSIONS ARE IN INCHES  
 TOLERANCES:  
 FRACTIONAL ± .003  
 ANGULAR: MACH ±.01 BEND ±  
 TWO PLACE DECIMAL ±  
 THREE PLACE DECIMAL ±.001

INTERPRET GEOMETRIC  
 TOLERANCING PER:

MATERIAL

FINISH

NAME DATE

DRAWN  
 CHECKED  
 ENG APPR.  
 MFG APPR.

Q.A.

COMMENTS:

TITLE:

**BX-DN-PLT31"-36W-TBK-CFA-WET-30K**

SIZE DWG. NO. REV

**A** TICKET 25562

SCALE: 1:8.5 WEIGHT: SHEET 1 OF 7

5

4

3

2

1

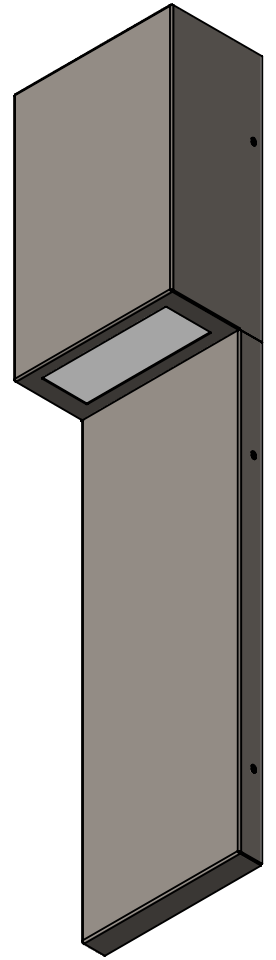
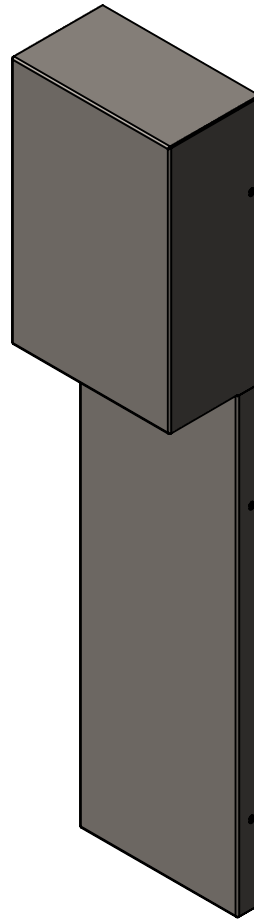
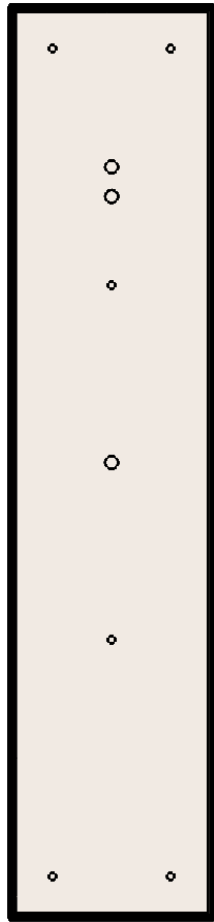
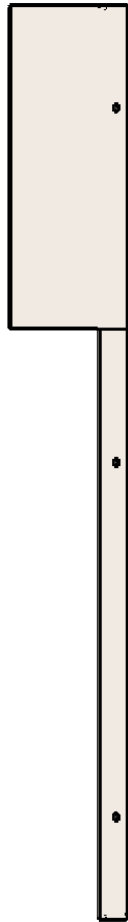
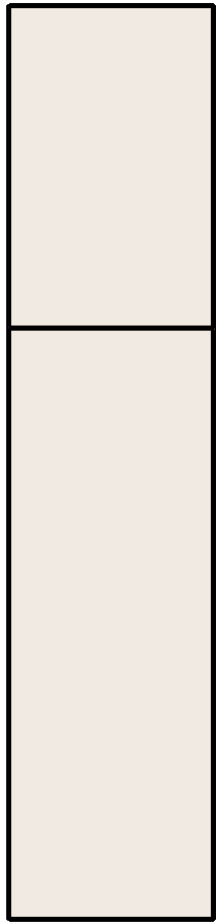

SPOT WELDED AS ONE

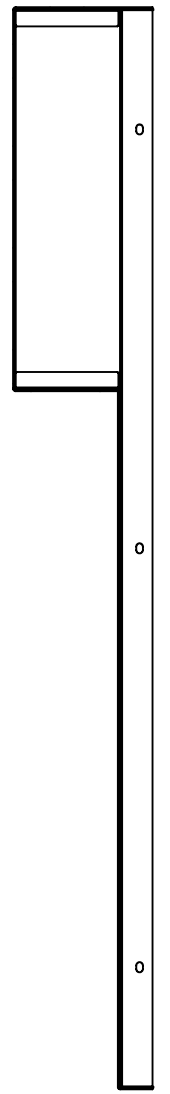
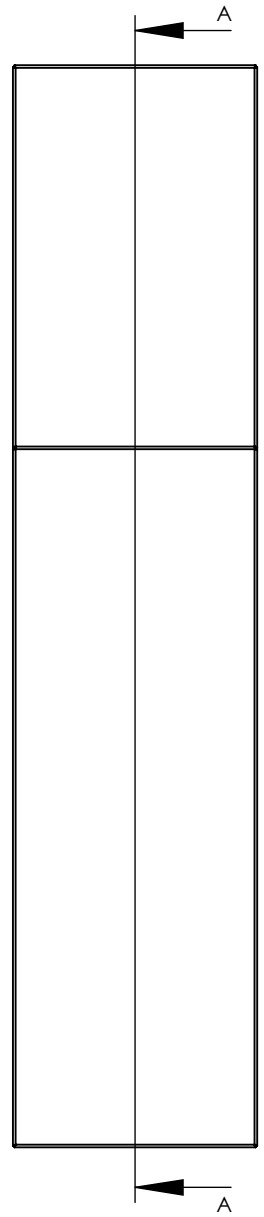
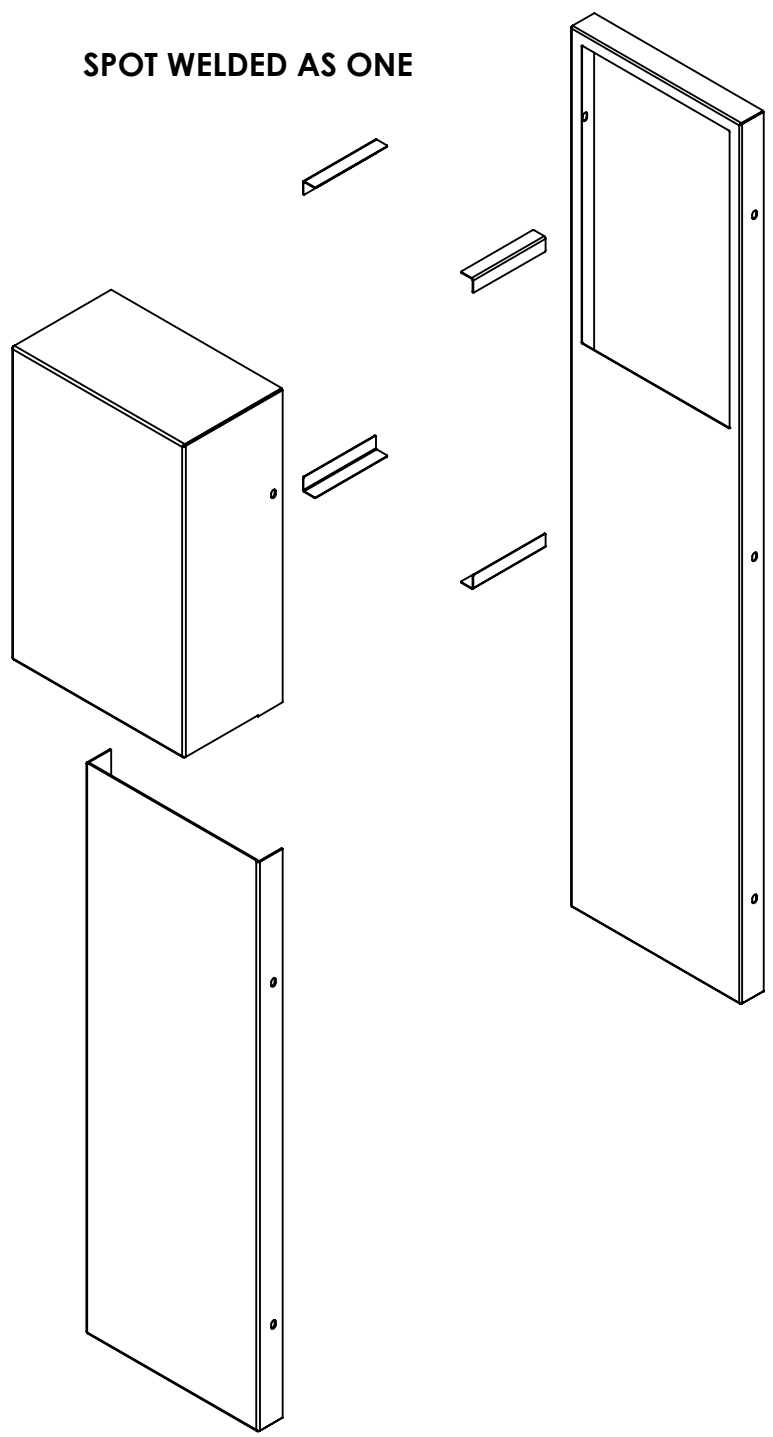

SECTION A-A

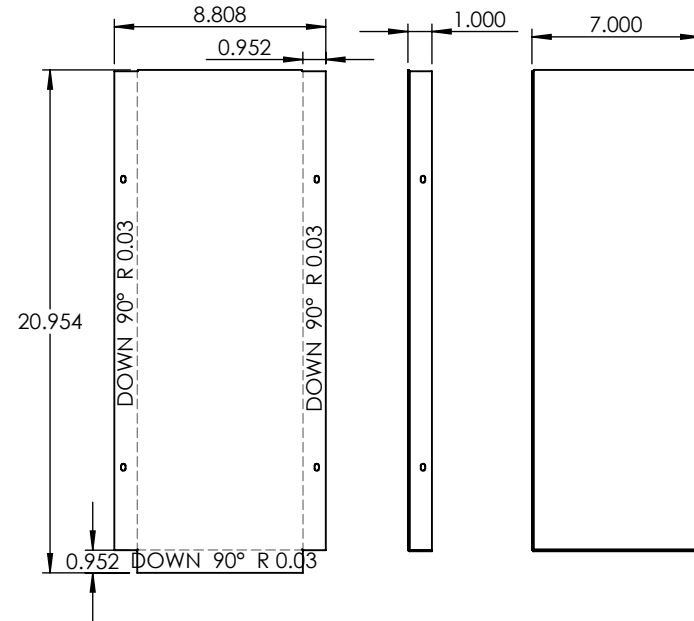
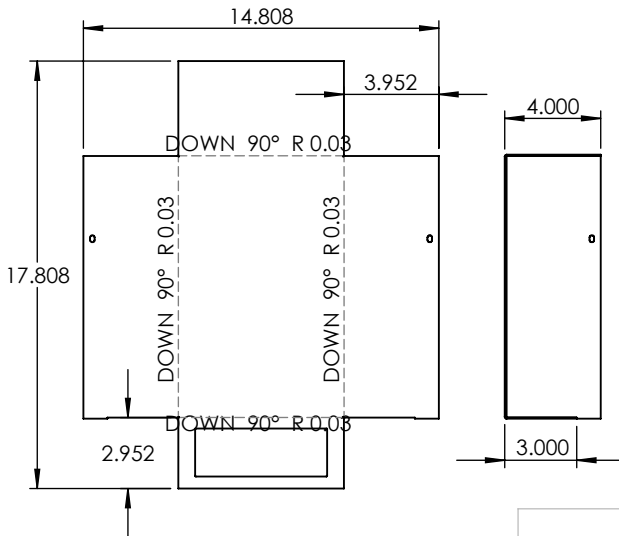
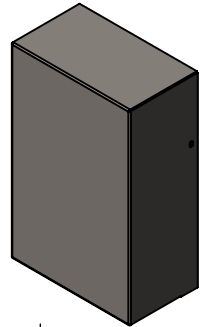
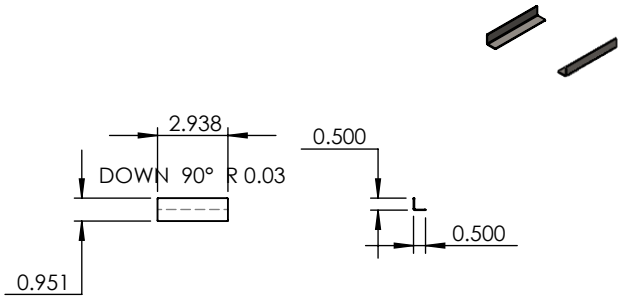

**PROPRIETARY AND CONFIDENTIAL**  
 THE INFORMATION CONTAINED IN THIS DRAWING IS THE SOLE PROPERTY OF <INSERT COMPANY NAME HERE>. ANY REPRODUCTION IN PART OR AS A WHOLE WITHOUT THE WRITTEN PERMISSION OF <INSERT COMPANY NAME HERE> IS PROHIBITED.

		UNLESS OTHERWISE SPECIFIED:		NAME	DATE	18 GAUGE	
		DIMENSIONS ARE IN INCHES TOLERANCES: FRACTIONAL ± ANGULAR: MACH ± BEND ± TWO PLACE DECIMAL ± THREE PLACE DECIMAL ±	DRAWN				
		INTERPRET GEOMETRIC TOLERANCING PER:	CHECKED			BX-DN-PLT31"-36W-TBK-CFA-WET-30K	
		MATERIAL	ENG APPR.			SIZE DWG. NO. REV	
NEXT ASSY	USED ON	FINISH	MFG APPR.			SCALE: 1:8 WEIGHT: SHEET 4 OF 7	
APPLICATION		DO NOT SCALE DRAWING	Q.A.				
			COMMENTS:				

5

4

3

2

1

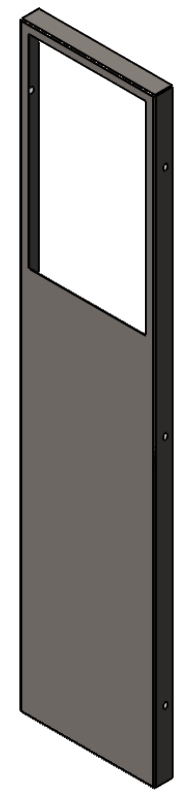
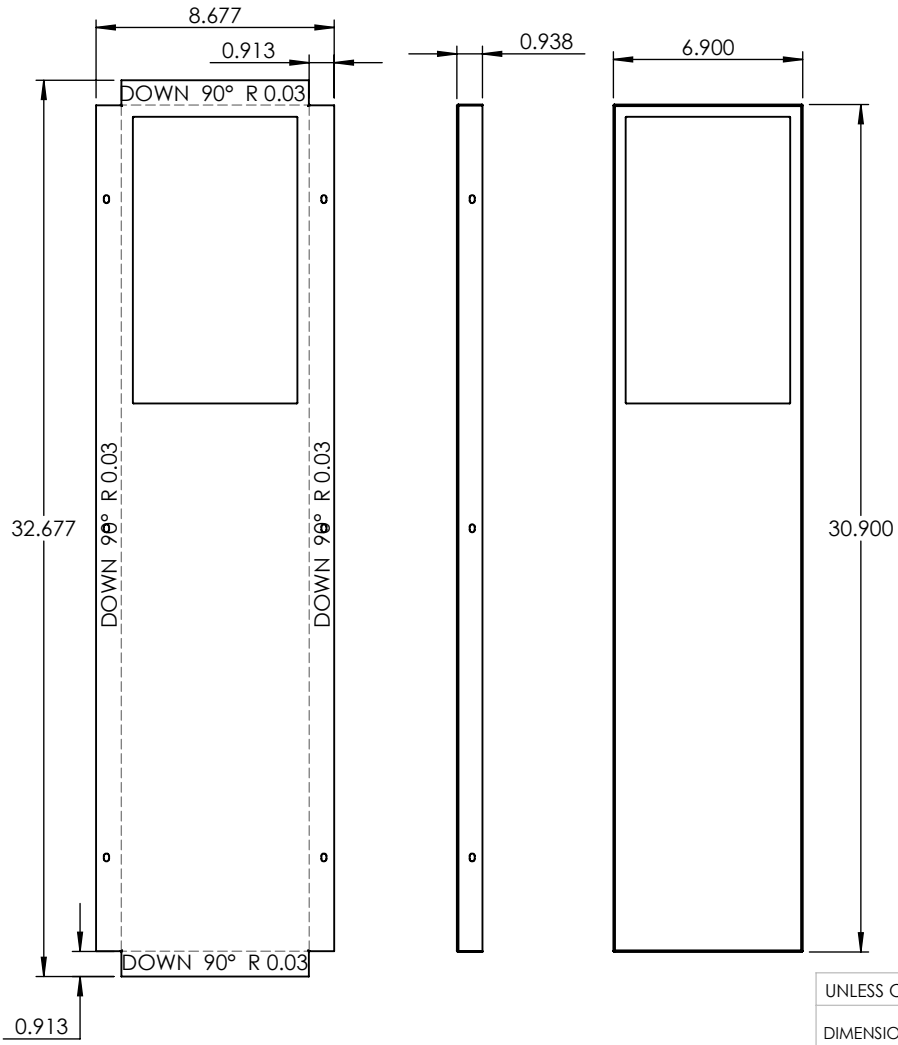

UNLESS OTHERWISE SPECIFIED:

DIMENSIONS ARE IN INCHES  
 TOLERANCES:  
 FRACTIONAL ±  
 ANGULAR: MACH ± BEND ±  
 TWO PLACE DECIMAL ±  
 THREE PLACE DECIMAL ±

INTERPRET GEOMETRIC TOLERANCING PER:

MATERIAL

FINISH

DO NOT SCALE DRAWING

NAME DATE

DRAWN  
 CHECKED  
 ENG APPR.  
 MFG APPR.  
 Q.A.  
 COMMENTS:

22 GAUGE

TITLE:  
 BX-DN-PLT31"-36W-TBK-CFA-WET-30K

SIZE	DWG. NO.	REV
<b>A</b>		
SCALE: 1:7	WEIGHT:	SHEET 5 OF 7

**PROPRIETARY AND CONFIDENTIAL**  
 THE INFORMATION CONTAINED IN THIS DRAWING IS THE SOLE PROPERTY OF <INSERT COMPANY NAME HERE>. ANY REPRODUCTION IN PART OR AS A WHOLE WITHOUT THE WRITTEN PERMISSION OF <INSERT COMPANY NAME HERE> IS PROHIBITED.

NEXT ASSY	USED ON
APPLICATION	

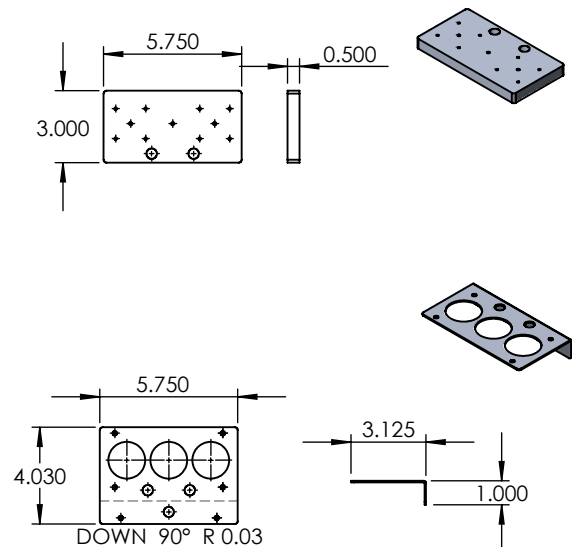
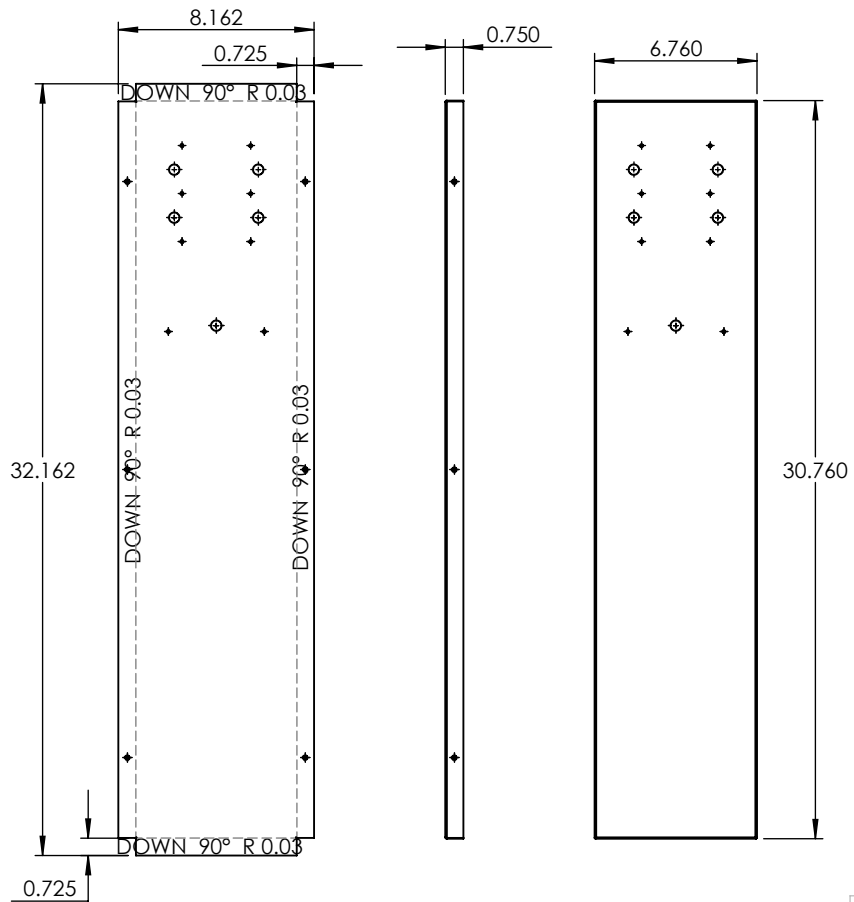

UNLESS OTHERWISE SPECIFIED:		NAME	DATE	22 GAUGE	
DIMENSIONS ARE IN INCHES TOLERANCES: FRACTIONAL ± ANGULAR: MACH ± BEND ± TWO PLACE DECIMAL ± THREE PLACE DECIMAL ±		DRAWN			
INTERPRET GEOMETRIC TOLERANCING PER:		CHECKED		SIZE DWG. NO. REV	
MATERIAL		ENG APPR.			
FINISH		MFG APPR.		COMMENTS:	
APPLICATION		Q.A.			
DO NOT SCALE DRAWING		COMMENTS:		A	

**PROPRIETARY AND CONFIDENTIAL**  
THE INFORMATION CONTAINED IN THIS DRAWING IS THE SOLE PROPERTY OF <INSERT COMPANY NAME HERE>. ANY REPRODUCTION IN PART OR AS A WHOLE WITHOUT THE WRITTEN PERMISSION OF <INSERT COMPANY NAME HERE> IS PROHIBITED.

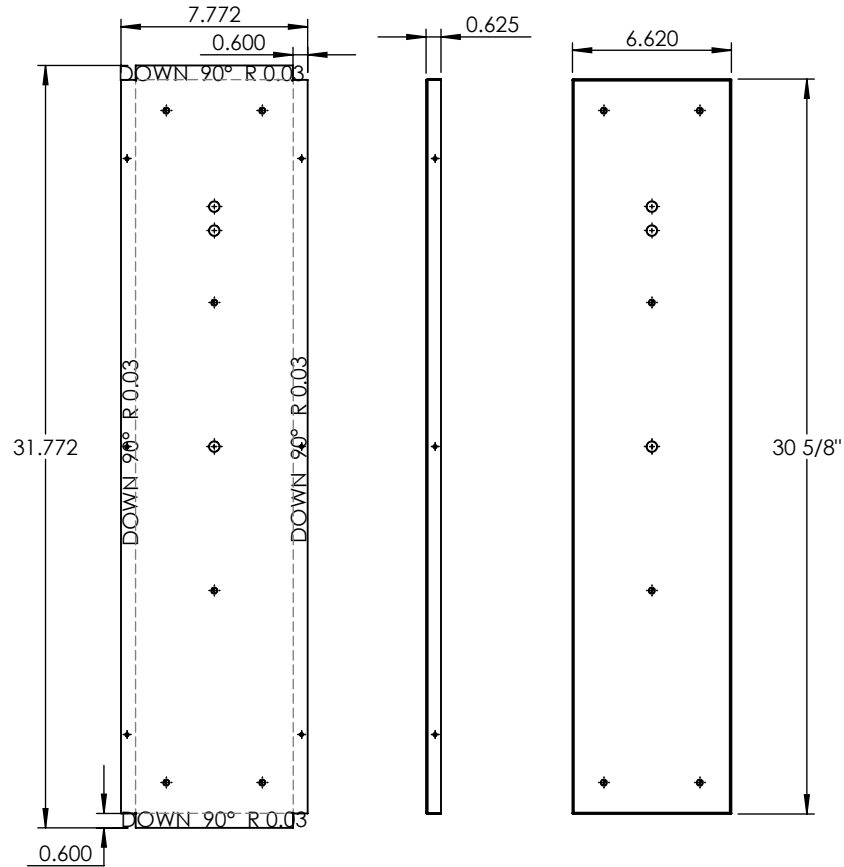
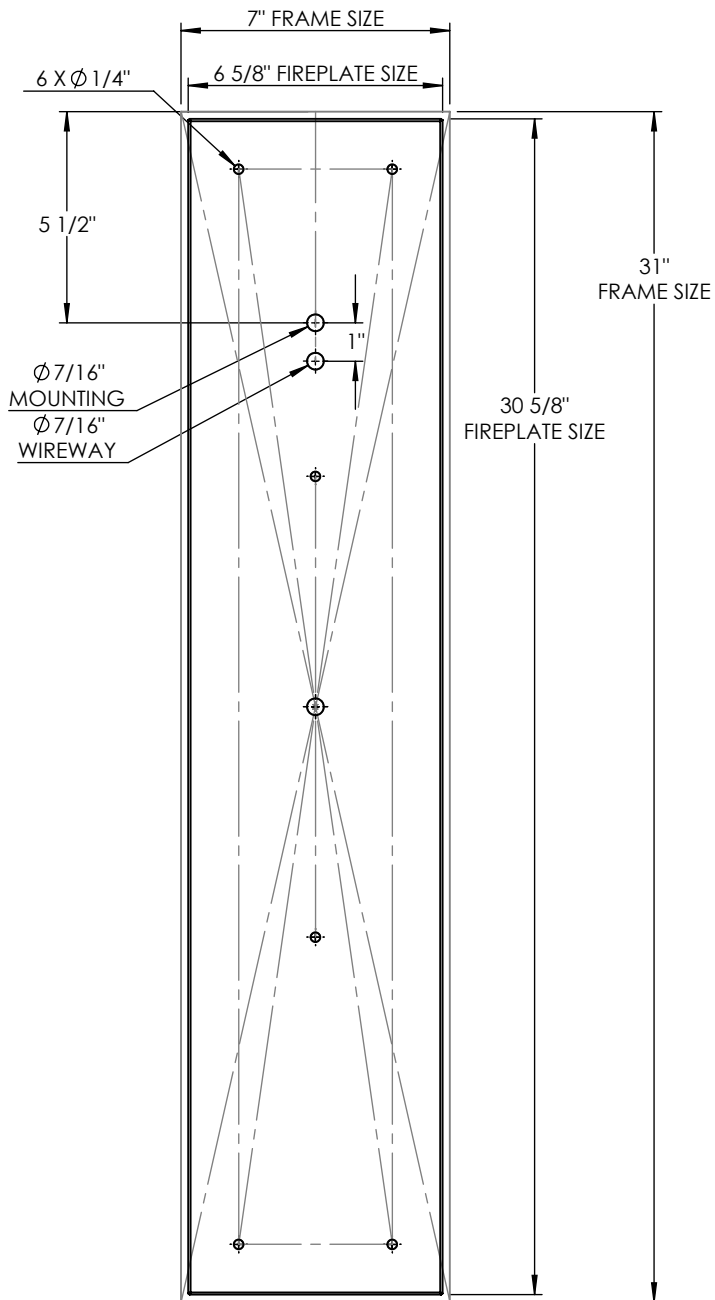

UNLESS OTHERWISE SPECIFIED:  
 DIMENSIONS ARE IN INCHES  
 TOLERANCES:  
 FRACTIONAL ±  
 ANGULAR: MACH ± BEND ±  
 TWO PLACE DECIMAL ±  
 THREE PLACE DECIMAL ±

	NAME	DATE
DRAWN		
CHECKED		
ENG APPR.		
MFG APPR.		

**22 GAUGE**

TITLE:  
**BX-DN-PLT31"-36W-TBK-CFA-WET-30K**

**PROPRIETARY AND CONFIDENTIAL**  
 THE INFORMATION CONTAINED IN THIS DRAWING IS THE SOLE PROPERTY OF <INSERT COMPANY NAME HERE>. ANY REPRODUCTION IN PART OR AS A WHOLE WITHOUT THE WRITTEN PERMISSION OF <INSERT COMPANY NAME HERE> IS PROHIBITED.

NEXT ASSY	USED ON
APPLICATION	

INTERPRET GEOMETRIC TOLERANCING PER:  
 MATERIAL  
 FINISH  
 DO NOT SCALE DRAWING

COMMENTS:

SIZE	DWG. NO.	REV
<b>A</b>		
SCALE: 1:8	WEIGHT:	SHEET 7 OF 7