

ALL BEND RADIUS .030"

UNLESS OTHERWISE SPECIFIED:
 DIMENSIONS ARE IN INCHES
 TOLERANCES:
 FRACTIONAL ± .003
 ANGULAR: MACH ± .01 BEND ±
 TWO PLACE DECIMAL ±
 THREE PLACE DECIMAL ±.001
 INTERPRET GEOMETRIC
 TOLERANCING PER:
 MATERIAL
 FINISH
 APPLICATION
 DO NOT SCALE DRAWING

| NAME | DATE |
|-----------|------|
| DRAWN | |
| CHECKED | |
| ENG APPR. | |
| MFG APPR. | |
| Q.A. | |
| COMMENTS: | |

| FIXTURE HEAD | | |
|-------------------------------|--------------|---------------|
| TITLE: COZ3215LS-TVP-A-30K | | |
| SIZE | DWG. NO. | REV |
| A | TICKET 25573 | |
| SCALE: 1:8 | WEIGHT: | SHEET 1 OF 13 |

5

4

3

2

1

| ITEM NO. | PART NUMBER | DESCRIPTION | QTY. | CUT |
|----------|---------------------------------------|-------------------------|------|-----|
| 1 | CANOPY | SPUN 18 GAUGE | 1 | |
| 2 | FIREPLATE | SPUN 18 GAUGE | 1 | |
| 3 | COZ3320LAB-A-35K-TOP SPUN BOWL | SPUN 22 GAUGE | 1 | |
| 4 | COZ3320LAB-A-35K-TOP SPUN CUP | SPUN 22 GAUGE | 1 | |
| 5 | COZ3215LS-TVP-A-30K-TOP CAP | 22 GAUGE | 1 | |
| 6 | COZ3215LS-TVP-A-30K-FRAME TOP BEND | 22 GAUGE | 6 | |
| 7 | COZ3215LS-TVP-A-30K-FRAME TABS | 22 GAUGE | 6 | |
| 8 | COZ3215LS-TVP-A-30K-DOOR | 22 GAUGE | 1 | |
| 9 | COZ3215LS-TVP-A-30K-FRAME BOTTOM BEND | 22 GAUGE | 6 | |
| 10 | COZ3215LS-TVP-A-30K-BOTTOM CAP | 22 GAUGE | 1 | |
| 11 | COZ3215LS-TVP-A-30K-BRACKET TABS | 22 GAUGE | 2 | |
| 12 | COZ3215LS-TVP-A-30K-LED BRACKET | 22 GAUGE | 1 | |
| 13 | COZ3215LS-TVP-A-30K-TUBE BRACKET | 22 GAUGE | 1 | |
| 14 | COZ3215LS-TVP-A-30K-ACRYLIC | ACRYLIC | 6 | |
| 15 | COZ3215LS-TVP-A-30K-SQUARE TUBE | 1" SQUARE ALUMINUM TUBE | 1 | |
| 16 | CHAIN BRACKET | BRASS | 2 | |
| 17 | Espen VEL19070MVH-1 | DRIVER | 1 | |
| 18 | AlfaLED_PN1012_RevD | LED | 4 | |

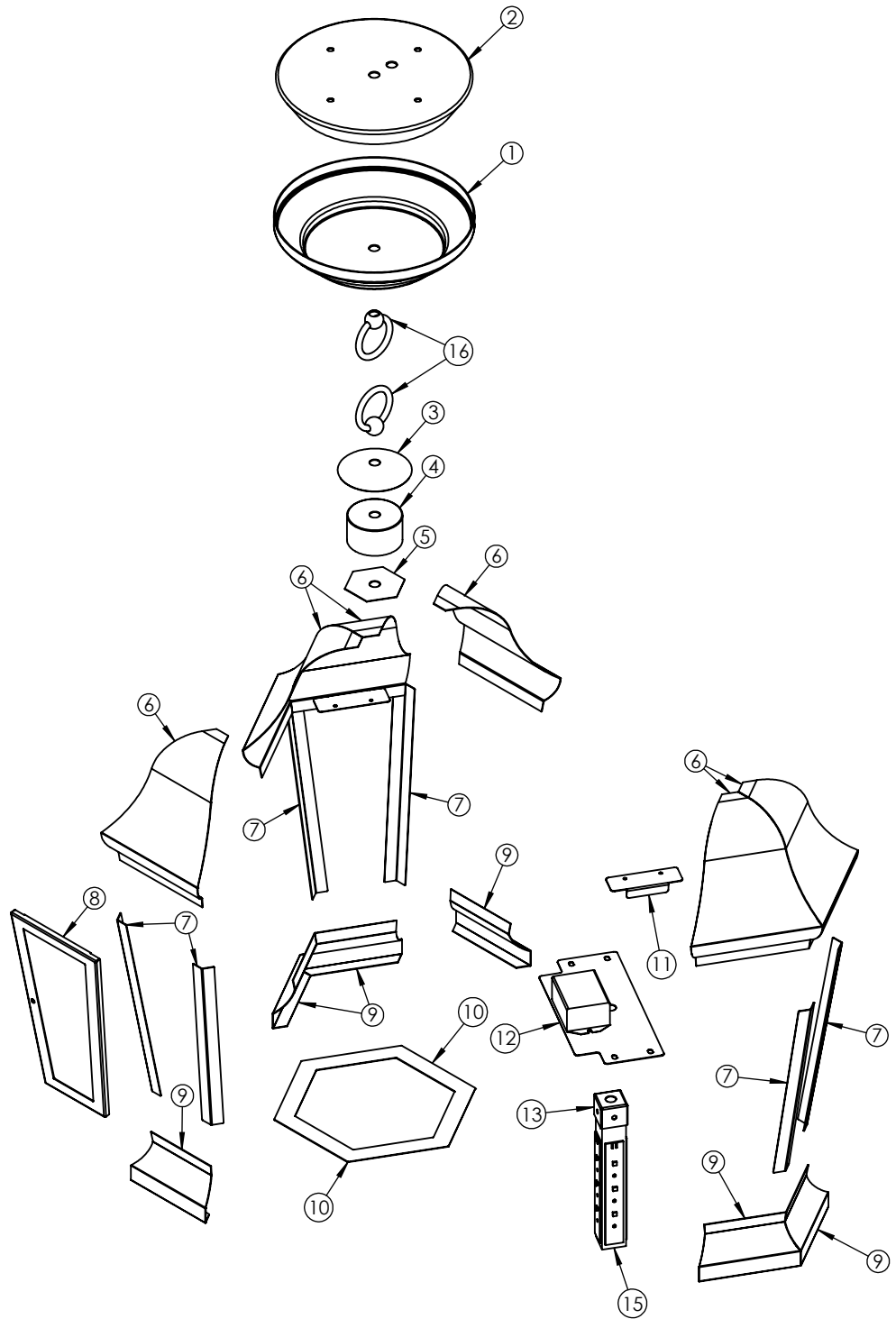

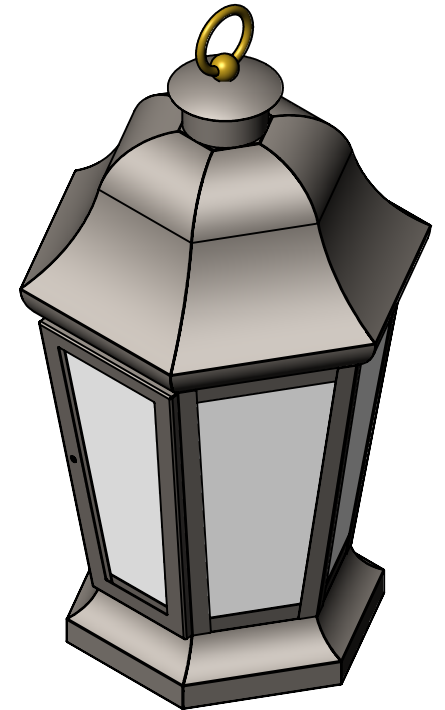
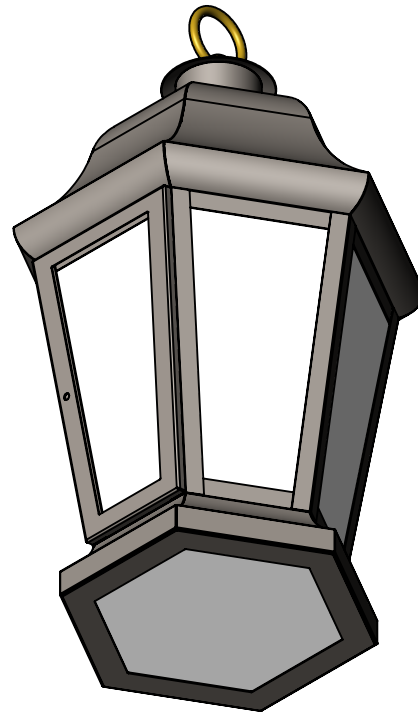
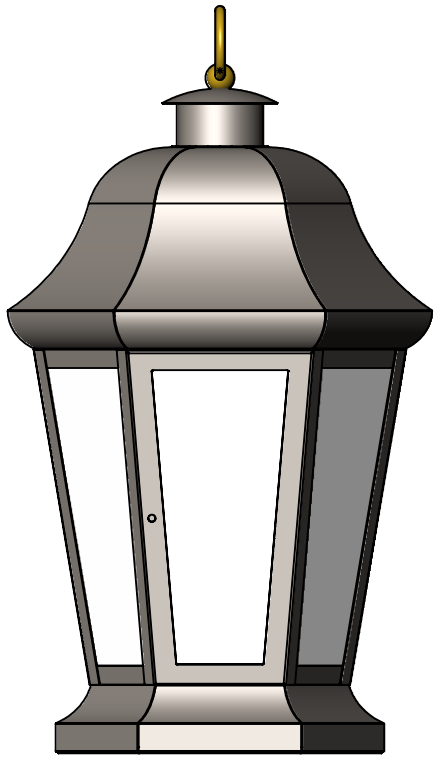
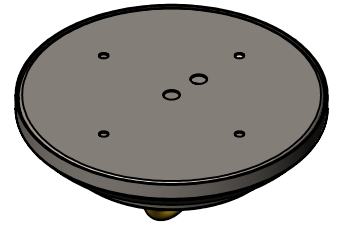
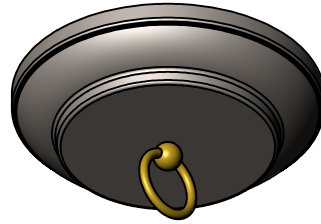
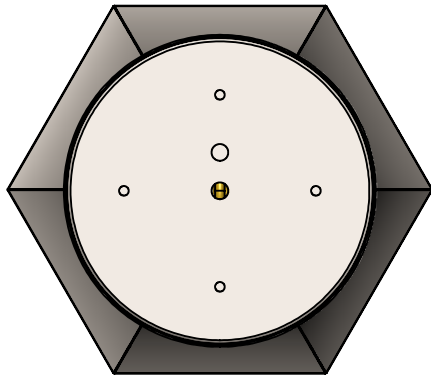
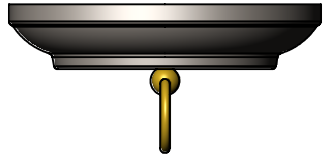

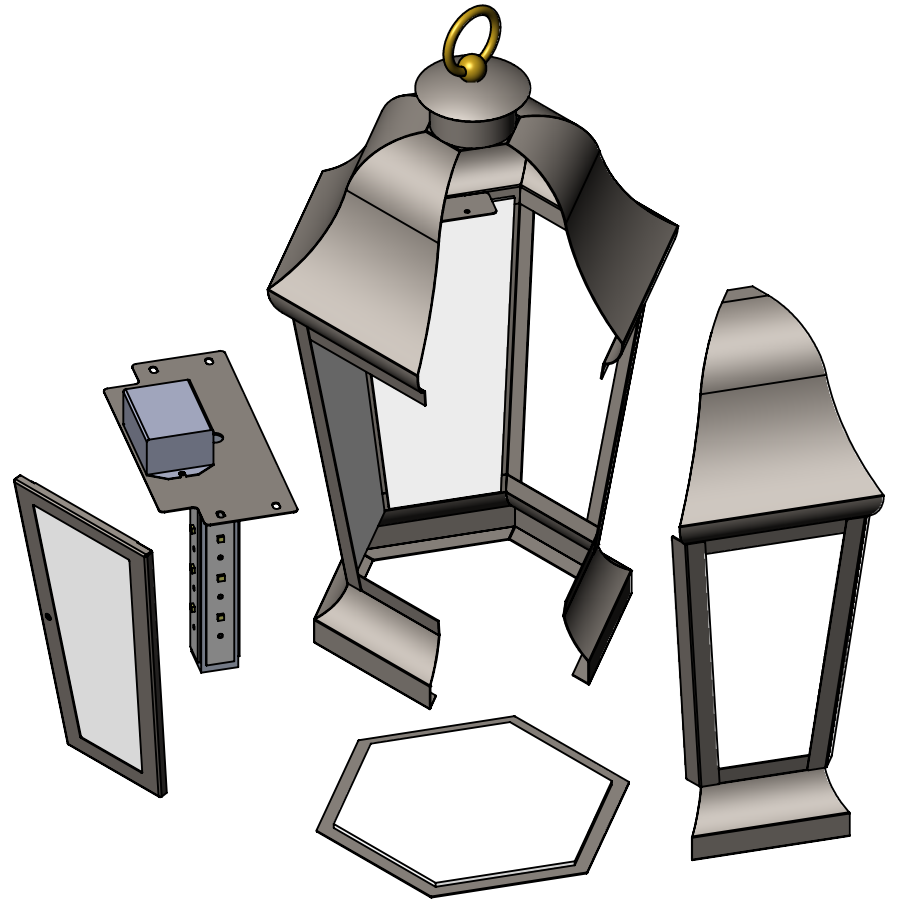
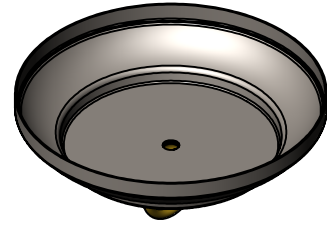
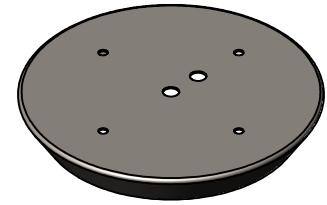
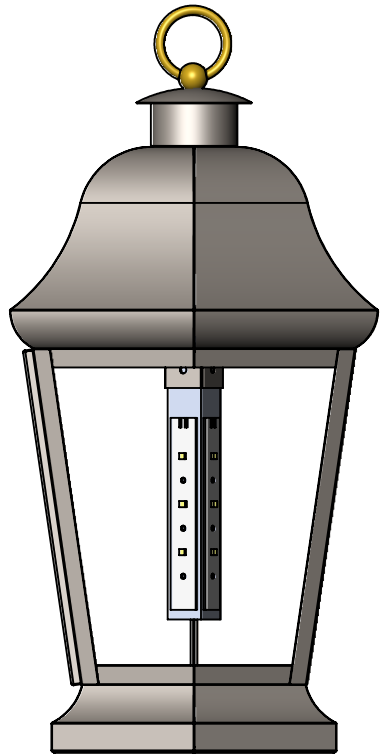
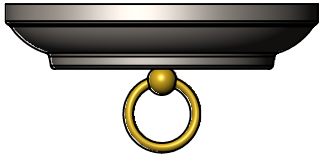

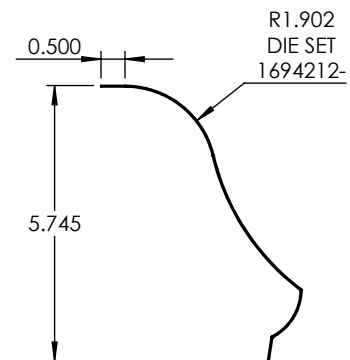
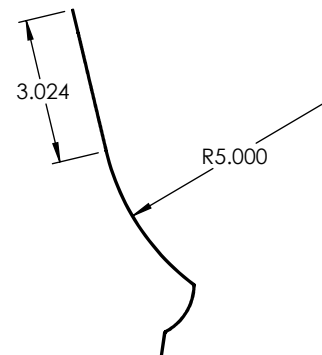
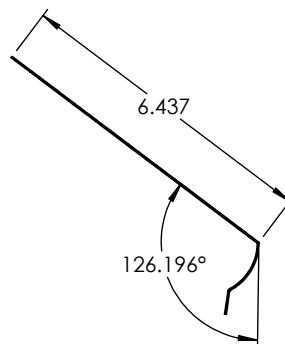
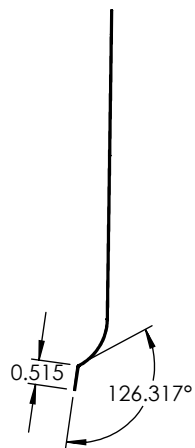
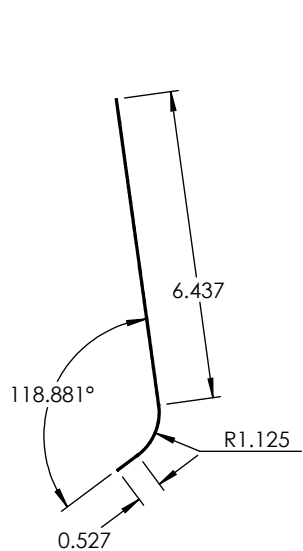
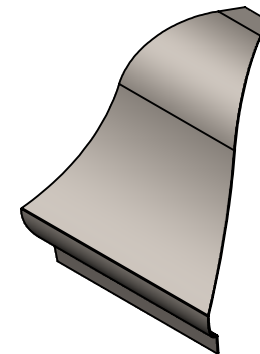
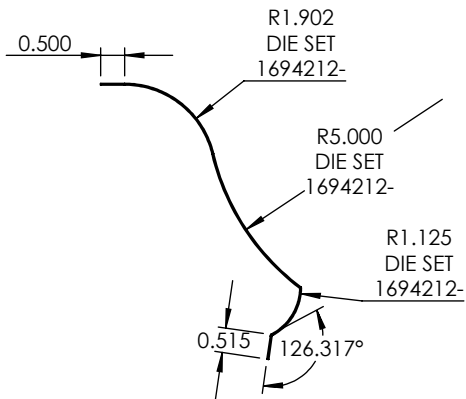
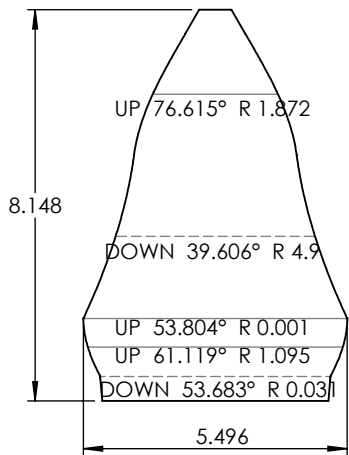

PROPRIETARY AND CONFIDENTIAL
 THE INFORMATION CONTAINED IN THIS DRAWING IS THE SOLE PROPERTY OF <INSERT COMPANY NAME HERE>. ANY REPRODUCTION IN PART OR AS A WHOLE WITHOUT THE WRITTEN PERMISSION OF <INSERT COMPANY NAME HERE> IS PROHIBITED.

| | | | | | |
|-------------|---------|--------------------------------------|-----------|------|------|
| | | UNLESS OTHERWISE SPECIFIED: | | NAME | DATE |
| | | DIMENSIONS ARE IN INCHES | DRAWN | | |
| | | TOLERANCES: | CHECKED | | |
| | | FRACTIONAL ± | ENG APPR. | | |
| | | ANGULAR: MACH ± BEND ± | MFG APPR. | | |
| | | TWO PLACE DECIMAL ± | Q.A. | | |
| | | THREE PLACE DECIMAL ± | COMMENTS: | | |
| | | INTERPRET GEOMETRIC TOLERANCING PER: | | | |
| | | MATERIAL | | | |
| | | FINISH | | | |
| NEXT ASSY | USED ON | | | | |
| APPLICATION | | DO NOT SCALE DRAWING | | | |

| | | |
|-------------------------------|----------|---------------|
| 22 GAUGE | | |
| TITLE: COZ3215LS-TVP-A-30K | | |
| SIZE A | DWG. NO. | REV |
| SCALE: 1:4 | WEIGHT: | SHEET 5 OF 13 |

5

4

3

2

1

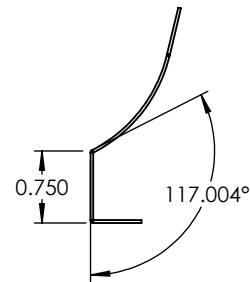
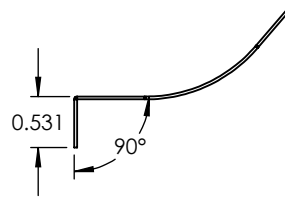
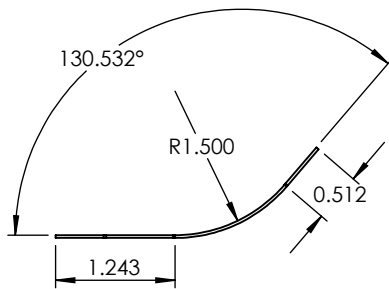
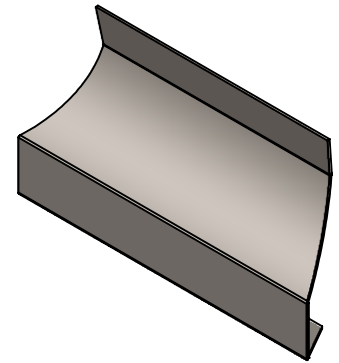
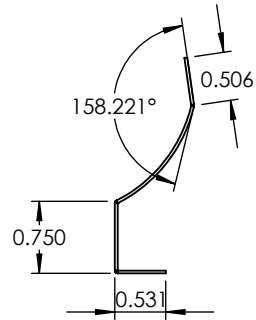
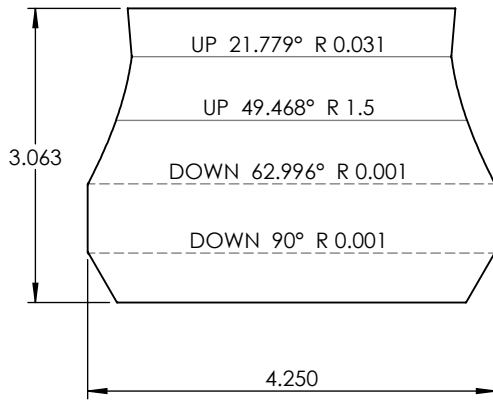

PROPRIETARY AND CONFIDENTIAL
 THE INFORMATION CONTAINED IN THIS DRAWING IS THE SOLE PROPERTY OF <INSERT COMPANY NAME HERE>. ANY REPRODUCTION IN PART OR AS A WHOLE WITHOUT THE WRITTEN PERMISSION OF <INSERT COMPANY NAME HERE> IS PROHIBITED.

| | | | | | | | |
|-------------|---------|---|--|-----------|------|-------------------|--|
| | | UNLESS OTHERWISE SPECIFIED: | | NAME | DATE | 22 GAUGE | |
| | | DIMENSIONS ARE IN INCHES TOLERANCES: FRACTIONAL ± ANGULAR: MACH ± BEND ± TWO PLACE DECIMAL ± THREE PLACE DECIMAL ± | | DRAWN | | | |
| | | INTERPRET GEOMETRIC TOLERANCING PER: | | CHECKED | | SIZE DWG. NO. REV | |
| | | MATERIAL | | ENG APPR. | | | |
| | | FINISH | | MFG APPR. | | 1 | |
| NEXT ASSY | USED ON | | | Q.A. | | | |
| APPLICATION | | DO NOT SCALE DRAWING | | COMMENTS: | | | |

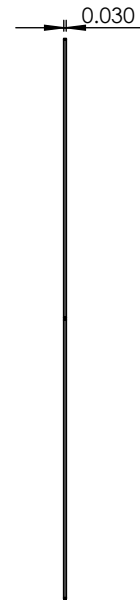
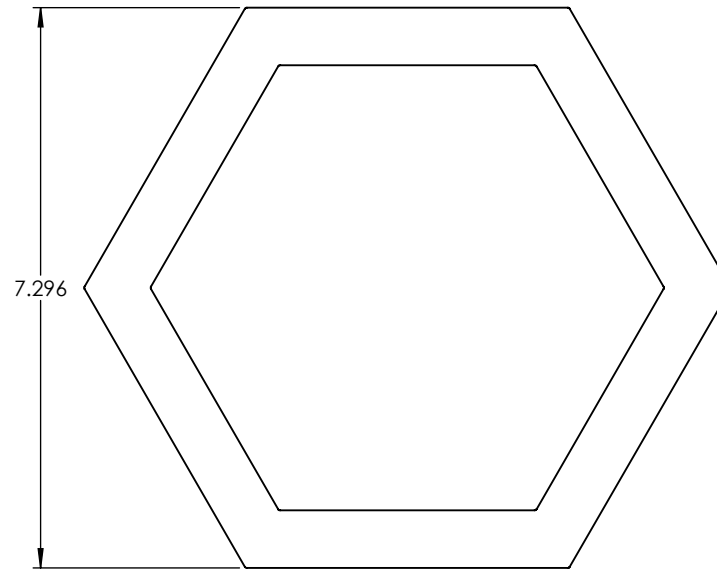
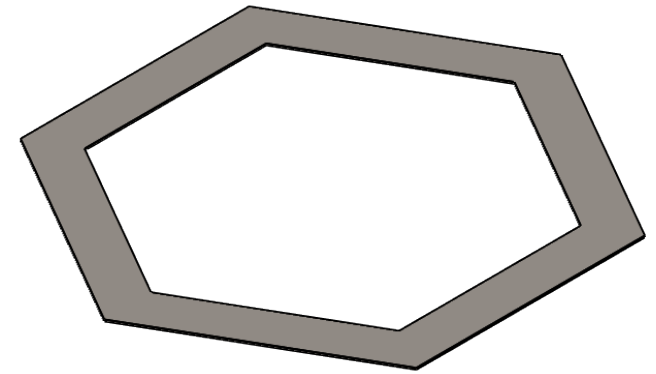
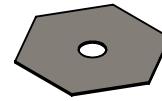
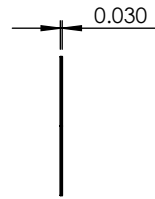
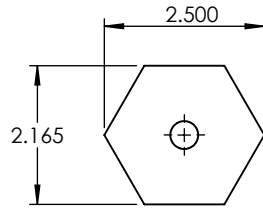
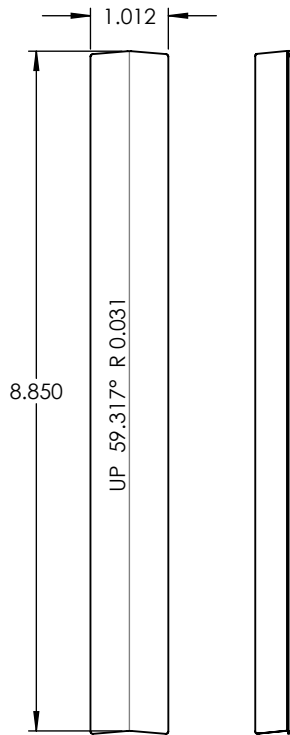
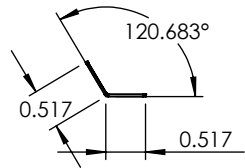

PROPRIETARY AND CONFIDENTIAL
 THE INFORMATION CONTAINED IN THIS DRAWING IS THE SOLE PROPERTY OF <INSERT COMPANY NAME HERE>. ANY REPRODUCTION IN PART OR AS A WHOLE WITHOUT THE WRITTEN PERMISSION OF <INSERT COMPANY NAME HERE> IS PROHIBITED.

| | | | | | | |
|-------------|---------|---|-----------|------|---------------|----------|
| | | UNLESS OTHERWISE SPECIFIED: | NAME | DATE | 22 GAUGE | |
| | | DIMENSIONS ARE IN INCHES TOLERANCES: FRACTIONAL ± ANGULAR: MACH ± BEND ± TWO PLACE DECIMAL ± THREE PLACE DECIMAL ± | DRAWN | | | |
| | | INTERPRET GEOMETRIC TOLERANCING PER: | CHECKED | | | |
| | | MATERIAL | ENG APPR. | | | |
| | | FINISH | MFG APPR. | | | |
| NEXT ASSY | USED ON | | Q.A. | | SIZE | DWG. NO. |
| APPLICATION | | DO NOT SCALE DRAWING | COMMENTS: | | A | |
| | | | | | SCALE: 1:2.5 | WEIGHT: |
| | | | | | SHEET 7 OF 13 | |

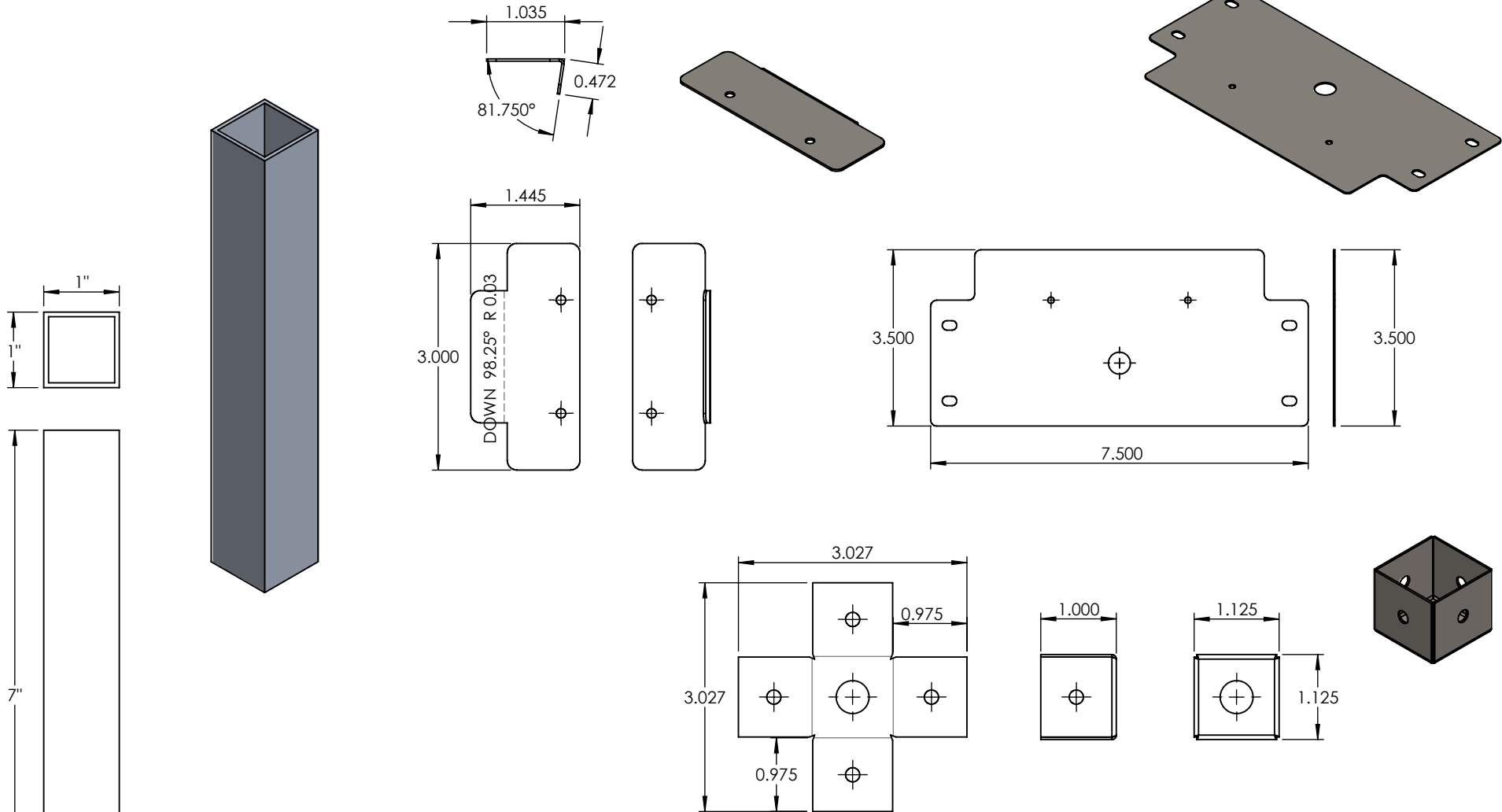

| | | | | |
|---|--|-----------|------|----------------------------------|
| UNLESS OTHERWISE SPECIFIED: | | NAME | DATE | 1" SQUARE ALUMINUM TUBE |
| DIMENSIONS ARE IN INCHES TOLERANCES: FRACTIONAL ± ANGULAR: MACH ± BEND ± TWO PLACE DECIMAL ± THREE PLACE DECIMAL ± | | DRAWN | | |
| INTERPRET GEOMETRIC TOLERANCING PER: | | CHECKED | | COZ3215LS-TVP-A-30K |
| MATERIAL | | ENG APPR. | | |
| FINISH | | MFG APPR. | | SCALE: 1:3 WEIGHT: SHEET 8 OF 13 |
| APPLICATION | | Q.A. | | |
| DO NOT SCALE DRAWING | | COMMENTS: | | |

PROPRIETARY AND CONFIDENTIAL
 THE INFORMATION CONTAINED IN THIS DRAWING IS THE SOLE PROPERTY OF <INSERT COMPANY NAME HERE>. ANY REPRODUCTION IN PART OR AS A WHOLE WITHOUT THE WRITTEN PERMISSION OF <INSERT COMPANY NAME HERE> IS PROHIBITED.

| | |
|-------------|---------|
| NEXT ASSY | USED ON |
| APPLICATION | |

5

4

3

2

1

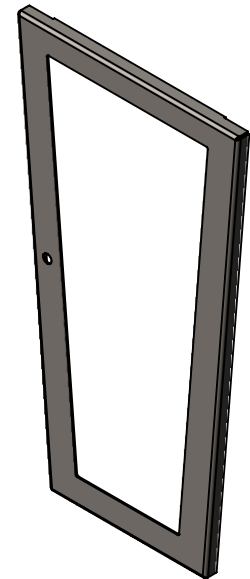
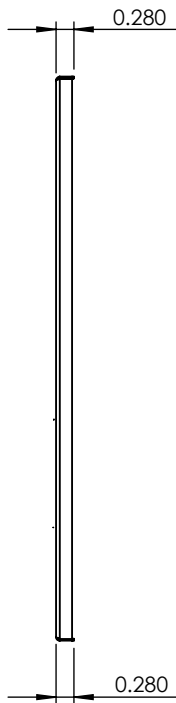
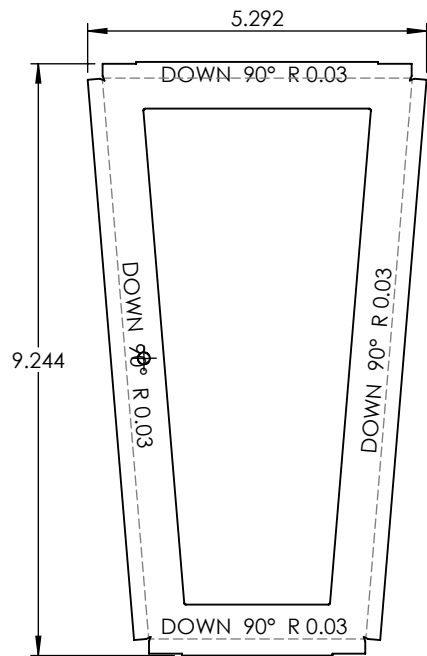

PROPRIETARY AND CONFIDENTIAL
 THE INFORMATION CONTAINED IN THIS DRAWING IS THE SOLE PROPERTY OF <INSERT COMPANY NAME HERE>. ANY REPRODUCTION IN PART OR AS A WHOLE WITHOUT THE WRITTEN PERMISSION OF <INSERT COMPANY NAME HERE> IS PROHIBITED.

| | | | | | | |
|-------------|---------|---|-----------|------|-------------------|--|
| | | UNLESS OTHERWISE SPECIFIED: | NAME | DATE | 22 GAUGE | |
| | | DIMENSIONS ARE IN INCHES TOLERANCES: FRACTIONAL ± ANGULAR: MACH ± BEND ± TWO PLACE DECIMAL ± THREE PLACE DECIMAL ± | DRAWN | | | |
| | | INTERPRET GEOMETRIC TOLERANCING PER: | CHECKED | | SIZE DWG. NO. REV | |
| | | MATERIAL | ENG APPR. | | | |
| | | FINISH | MFG APPR. | | | |
| NEXT ASSY | USED ON | | Q.A. | | | |
| APPLICATION | | DO NOT SCALE DRAWING | COMMENTS: | | | |

| ITEM NO. | PART NUMBER | DESCRIPTION | QTY. |
|----------|--------------------------------|---------------|------|
| 1 | COZ2112L-AB-A-30K-TOP SPUN CAP | SPUN 22 GAUGE | 1 |

| ITEM NO. | PART NUMBER | DESCRIPTION | QTY. |
|----------|-------------------------------|---------------|------|
| 1 | COZ3320LAB-A-35K-TOP SPUN CUP | SPUN 22 GAUGE | 1 |

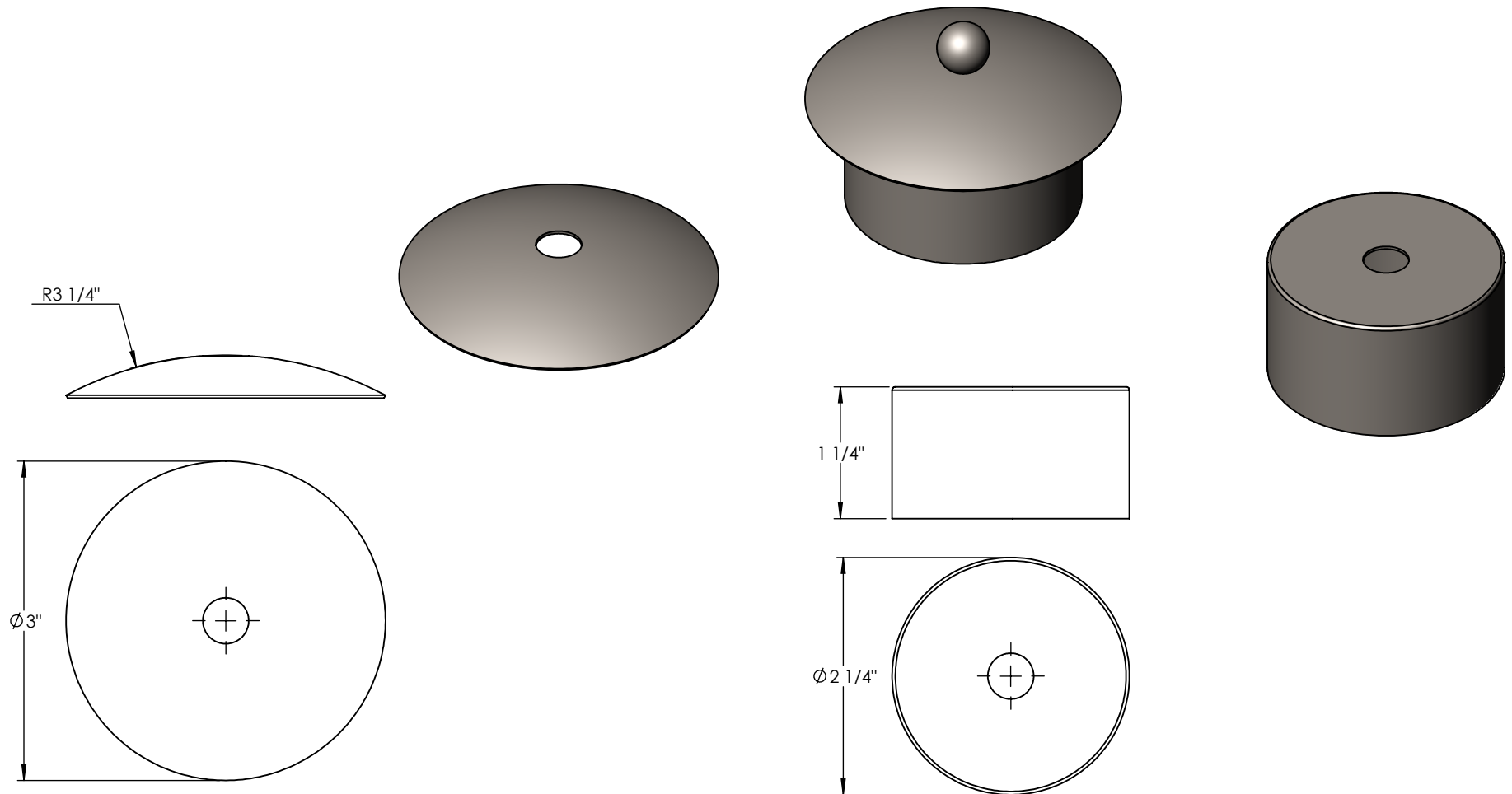

PROPRIETARY AND CONFIDENTIAL
 THE INFORMATION CONTAINED IN THIS DRAWING IS THE SOLE PROPERTY OF <INSERT COMPANY NAME HERE>. ANY REPRODUCTION IN PART OR AS A WHOLE WITHOUT THE WRITTEN PERMISSION OF <INSERT COMPANY NAME HERE> IS PROHIBITED.

| | | | | | |
|-------------|---------|---|-----------|------|------|
| | | UNLESS OTHERWISE SPECIFIED: | | NAME | DATE |
| | | DIMENSIONS ARE IN INCHES TOLERANCES: FRACTIONAL ± ANGULAR: MACH ± BEND ± TWO PLACE DECIMAL ± THREE PLACE DECIMAL ± | DRAWN | | |
| | | INTERPRET GEOMETRIC TOLERANCING PER: | CHECKED | | |
| | | MATERIAL | ENG APPR. | | |
| | | FINISH | MFG APPR. | | |
| | | | Q.A. | | |
| | | | COMMENTS: | | |
| NEXT ASSY | USED ON | | | | |
| APPLICATION | | DO NOT SCALE DRAWING | | | |

| | | |
|---------------------|----------|----------------|
| TITLE: | | |
| SPUN 22 GAUGE | | |
| COZ3215LS-TVP-A-30K | | |
| SIZE | DWG. NO. | REV |
| A | | |
| SCALE: 1:1.5 | WEIGHT: | SHEET 10 OF 13 |

| ITEM NO. | PART NUMBER | DESCRIPTION | QTY. |
|----------|-------------|---------------|------|
| 1 | CANOPY | SPUN 18 GAUGE | 1 |

| ITEM NO. | PART NUMBER | DESCRIPTION | QTY. |
|----------|-------------|---------------|------|
| 1 | FIREPLATE | SPUN 18 GAUGE | 1 |

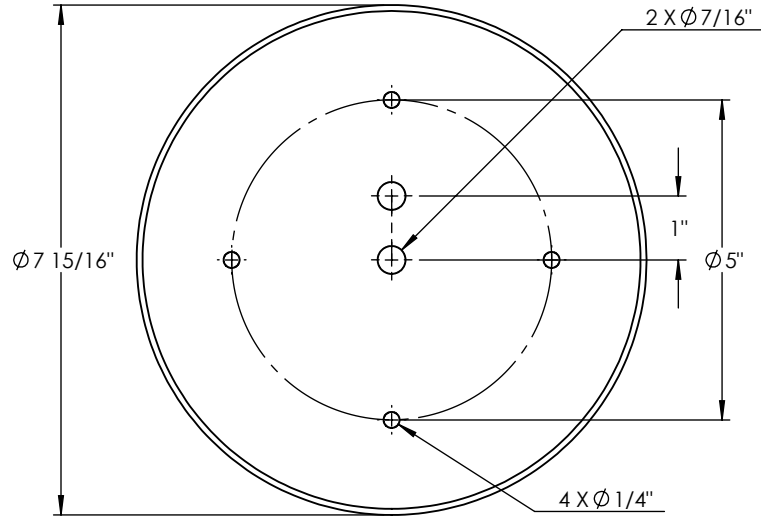
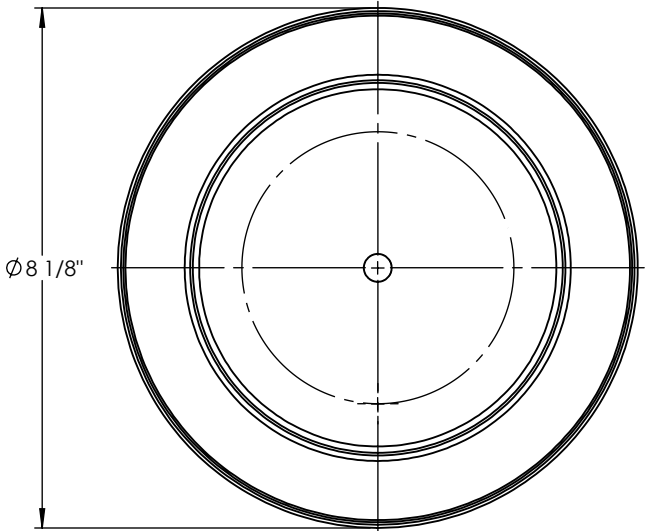
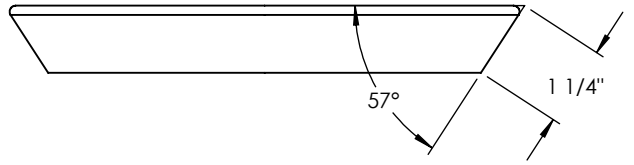
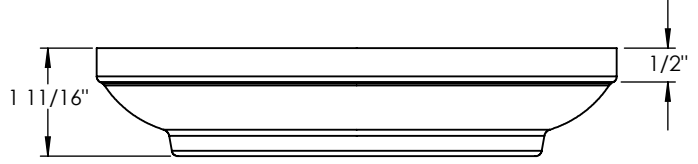
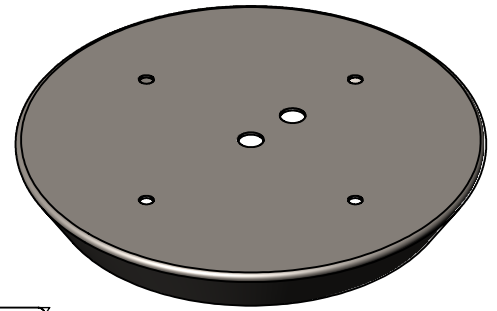
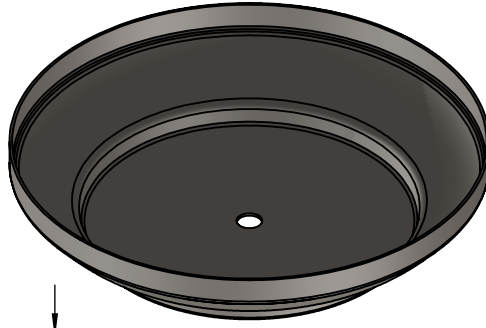

PROPRIETARY AND CONFIDENTIAL
 THE INFORMATION CONTAINED IN THIS DRAWING IS THE SOLE PROPERTY OF <INSERT COMPANY NAME HERE>. ANY REPRODUCTION IN PART OR AS A WHOLE WITHOUT THE WRITTEN PERMISSION OF <INSERT COMPANY NAME HERE> IS PROHIBITED.

| | | | | |
|-------------|---------|--------------------------------------|-----------|------|
| | | UNLESS OTHERWISE SPECIFIED: | NAME | DATE |
| | | DIMENSIONS ARE IN INCHES | DRAWN | |
| | | TOLERANCES: | CHECKED | |
| | | FRACTIONAL ± | ENG APPR. | |
| | | ANGULAR: MACH ± BEND ± | MFG APPR. | |
| | | TWO PLACE DECIMAL ± | Q.A. | |
| | | THREE PLACE DECIMAL ± | COMMENTS: | |
| | | INTERPRET GEOMETRIC TOLERANCING PER: | | |
| | | MATERIAL | | |
| NEXT ASSY | USED ON | FINISH | | |
| APPLICATION | | DO NOT SCALE DRAWING | | |

| | | |
|---------------------|----------|----------------|
| SPUN 18 GAUGE | | |
| TITLE: | | |
| COZ3215LS-TVP-A-30K | | |
| SIZE | DWG. NO. | REV |
| A | | |
| SCALE: 1:3 | WEIGHT: | SHEET 11 OF 13 |

5

4

3

2

1

