

ITEM NO.	PART NUMBER	DESCRIPTION	QTY.	CUT
1	802324L-AB-A-35K-CANOPY	22 GAUGE	1	
2	802324L-AB-A-35K-FIREPLATE	22 GAUGE	1	
3	802324L-AB-A-35K-DRIVER BRACKET	22 GAUGE	1	
4	802324L-AB-A-35K-TAB	22 GAUGE	4	
5	802324L-AB-A-35K-FRAME	22 GAUGE	2	
6	802324L-AB-A-35K-FRAME BACK	22 GAUGE	1	
7	802324L-AB-A-35K-CAP TRIM 3	22 GAUGE	2	
8	802324L-AB-A-35K-CAP TRIM 2	22 GAUGE	2	
9	802324L-AB-A-35K-CAP TRIM 1	22 GAUGE	2	
10	802324L-AB-A-35K-TOP CAP	22 GAUGE	1	
11	802324L-AB-A-35K-BOTTOM CAP	22 GAUGE	1	
12	802324L-AB-A-35K-TUBE BRACKET	22 GAUGE	1	
13	802324L-AB-A-35K-TUBE	1" SQR TUBE	1	
14	802324L-AB-A-35K-SMALL TUBE	5/8" ROUND ALUMINUM TUBE	1	
15	BRASS L JOINT	BRASS JOINT	1	
16	ESPEN VEL29070MVH-1	DRIVER	1	
17	AltAILED_PN1010_RevD	LED	4	

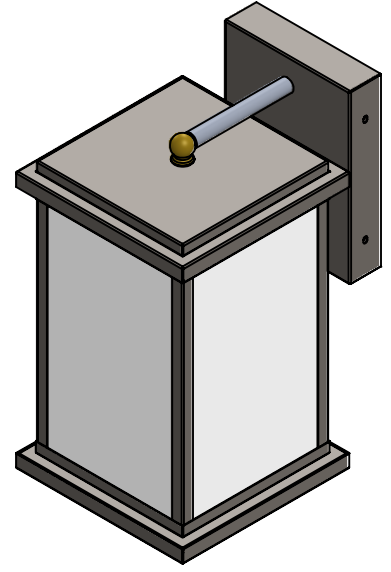
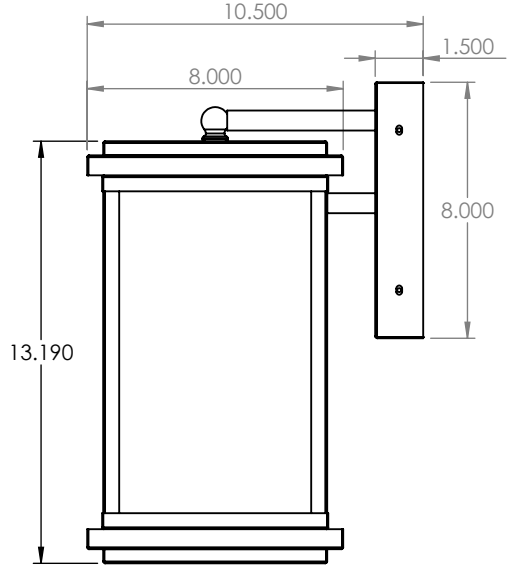
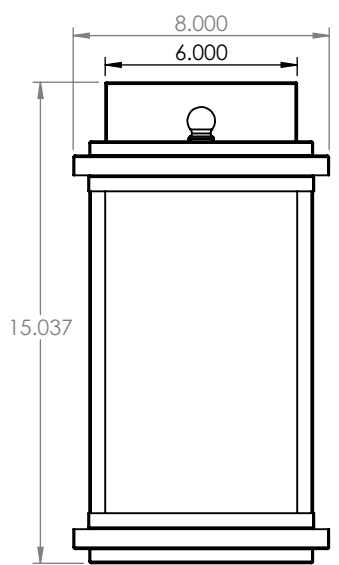
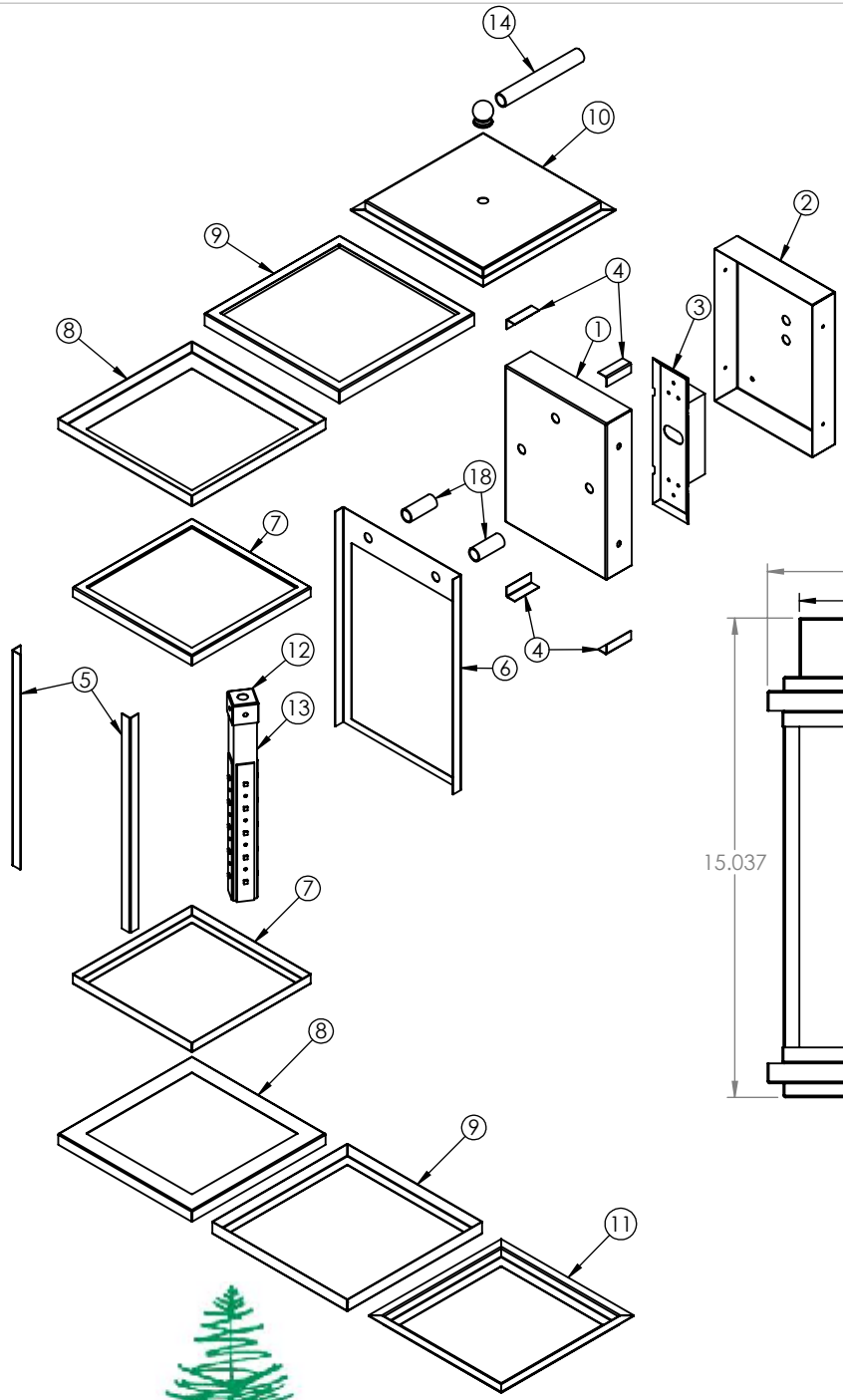

UNLESS OTHERWISE SPECIFIED:

DIMENSIONS ARE IN INCHES  
TOLERANCES:  
FRACTIONAL ± .003  
ANGULAR: MACH ±.01 BEND ±  
TWO PLACE DECIMAL ±  
THREE PLACE DECIMAL ±.001

INTERPRET GEOMETRIC  
TOLERANCING PER:

MATERIAL

FINISH

APPLICATION

DO NOT SCALE DRAWING

	NAME	DATE
DRAWN		
CHECKED		
ENG APPR.		
MFG APPR.		
Q.A.		
COMMENTS:		

TITLE:		
802320L-AB-A-AA-41K		
SIZE	DWG. NO.	REV
<b>A</b>	<b>TICKET 25579</b>	
SCALE: 1:8	WEIGHT:	SHEET 1 OF 10



ALL BEND RADIUS .030"

5

4

3

2

1

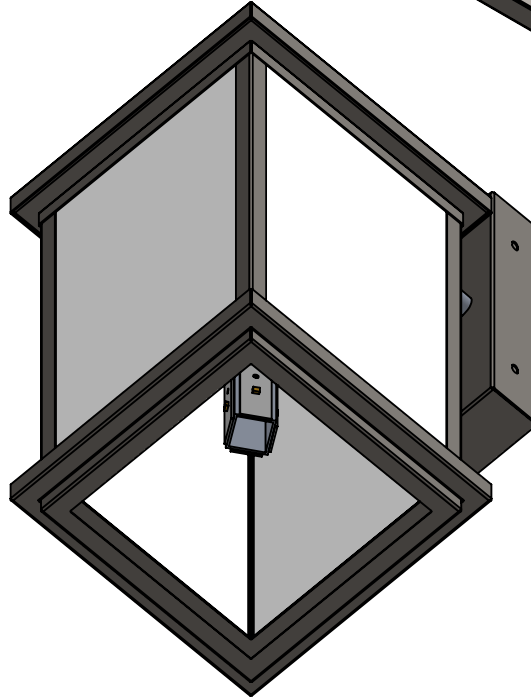
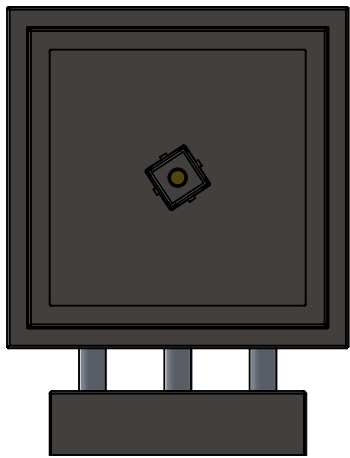
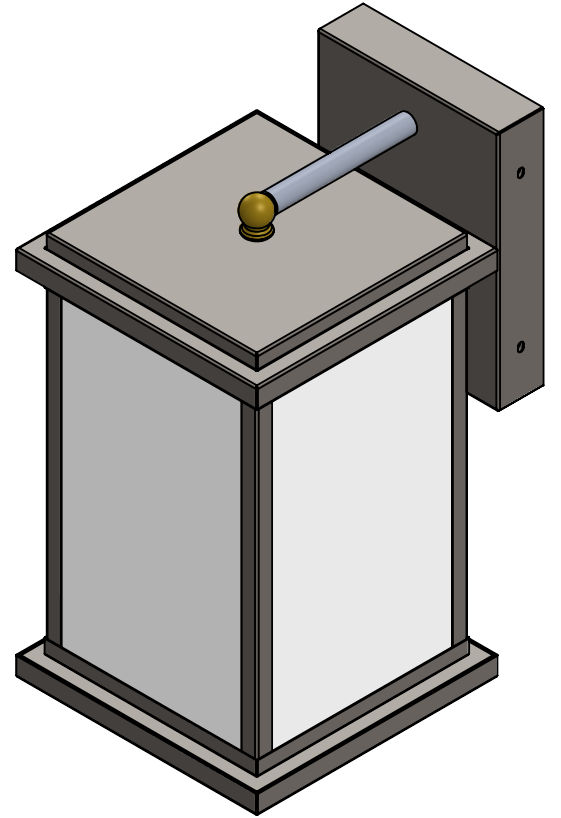
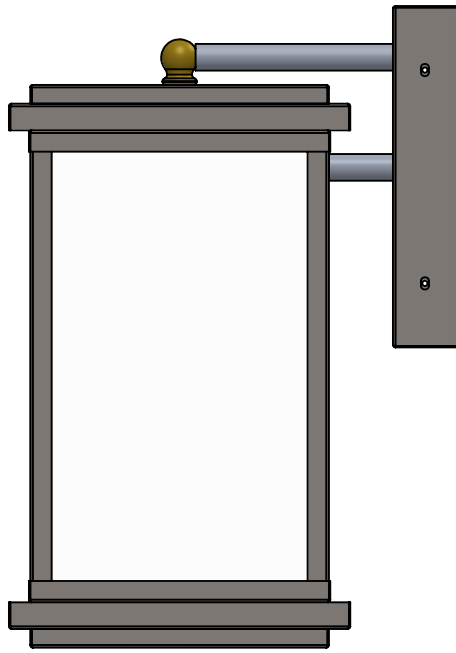
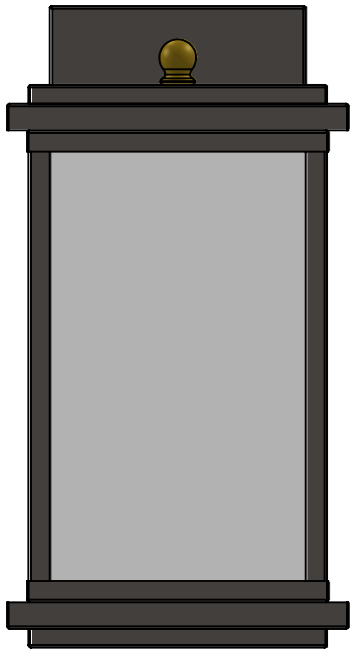

DRIVER BRACKET SPOT WELDED TO BACK OF  
BACKPLATE

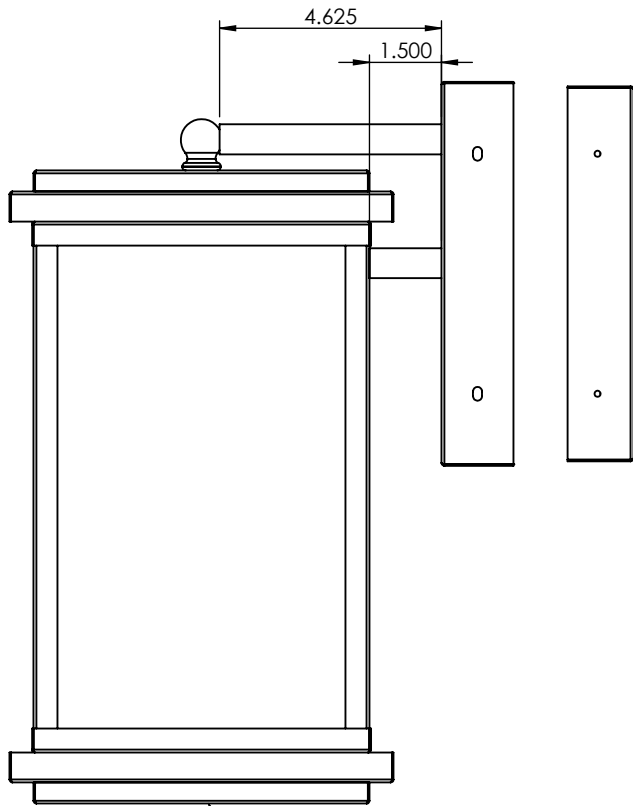

BOTTOM HAS DROP IN LENS OPENNING

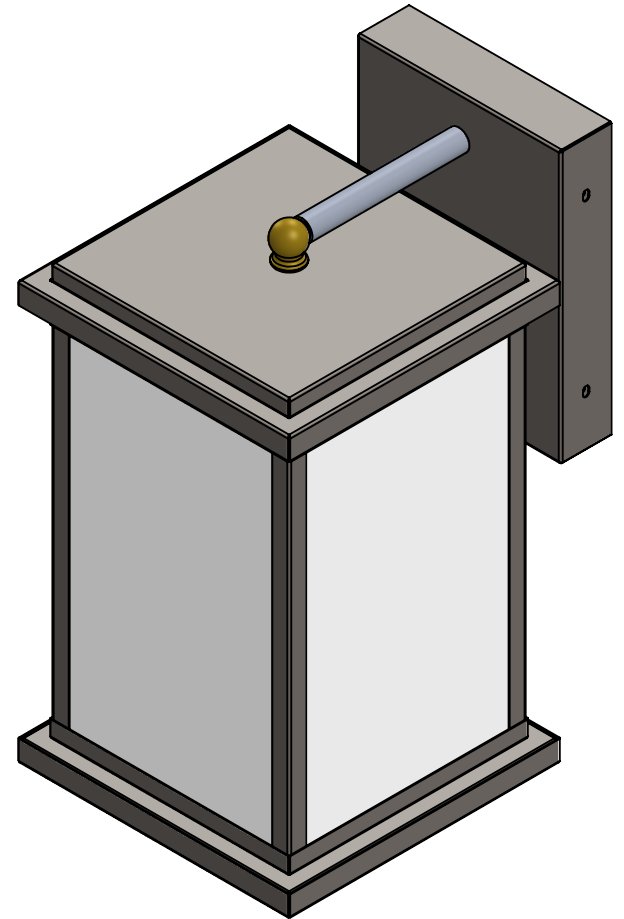
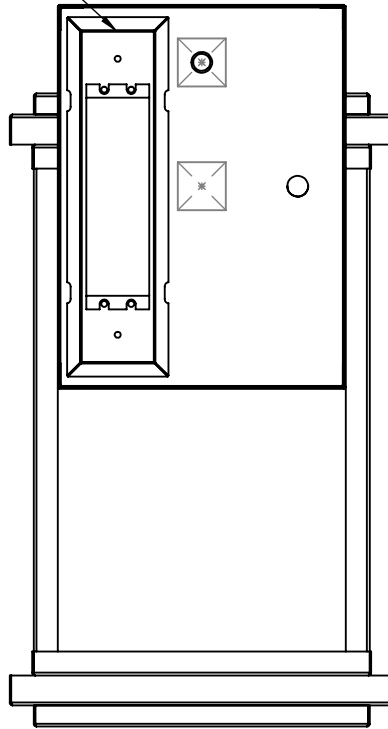

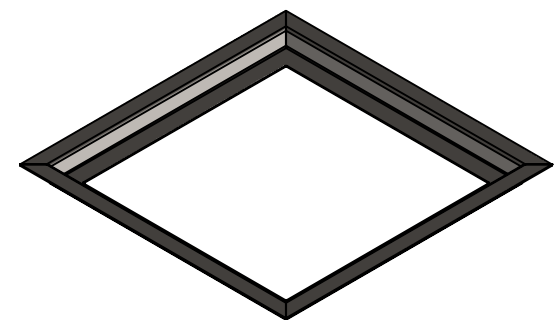
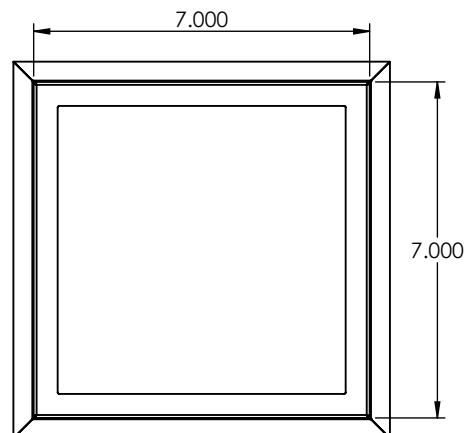
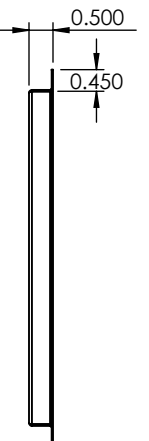
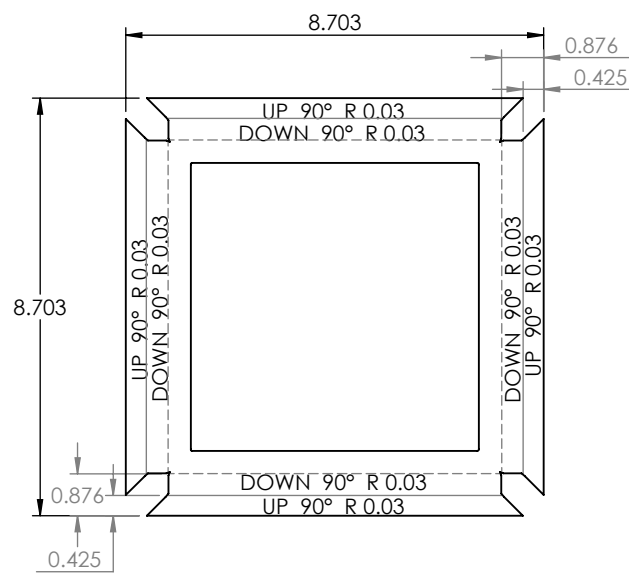
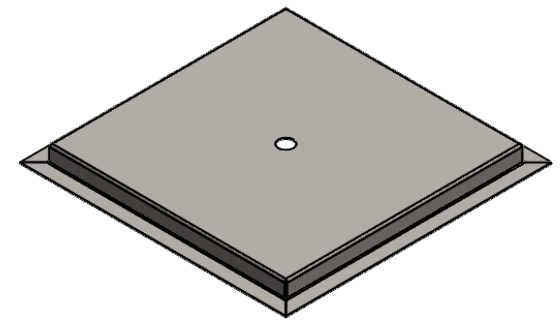
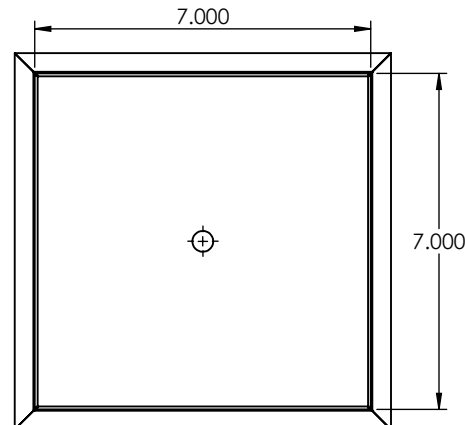
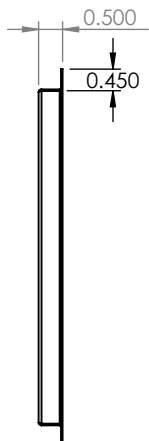
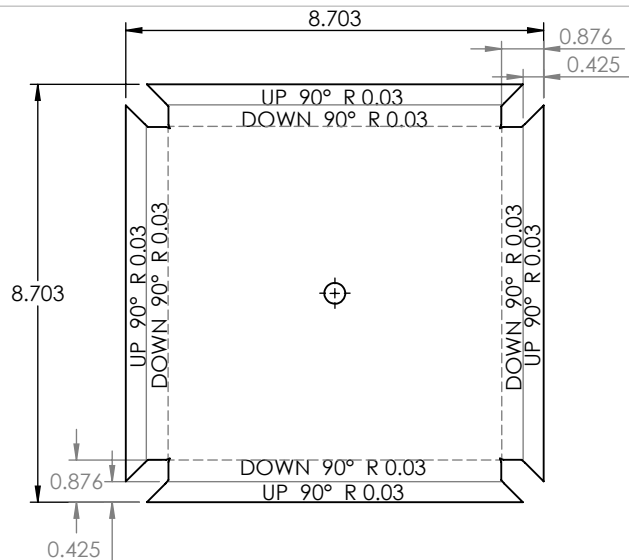

**PROPRIETARY AND CONFIDENTIAL**  
 THE INFORMATION CONTAINED IN THIS DRAWING IS THE SOLE PROPERTY OF <INSERT COMPANY NAME HERE>. ANY REPRODUCTION IN PART OR AS A WHOLE WITHOUT THE WRITTEN PERMISSION OF <INSERT COMPANY NAME HERE> IS PROHIBITED.

NEXT ASSY	USED ON
APPLICATION	

UNLESS OTHERWISE SPECIFIED:  
 DIMENSIONS ARE IN INCHES  
 TOLERANCES:  
 FRACTIONAL ±  
 ANGULAR: MACH ± BEND ±  
 TWO PLACE DECIMAL ±  
 THREE PLACE DECIMAL ±

INTERPRET GEOMETRIC TOLERANCING PER:  
 MATERIAL  
 FINISH

DO NOT SCALE DRAWING

	NAME	DATE
DRAWN		
CHECKED		
ENG APPR.		
MFG APPR.		
Q.A.		
COMMENTS:		

<b>22 GAUGE</b>		
TITLE: <b>802320L-AB-A-AA-41K</b>		
SIZE <b>A</b>	DWG. NO.	REV
SCALE: 1:4	WEIGHT:	SHEET 4 OF 10

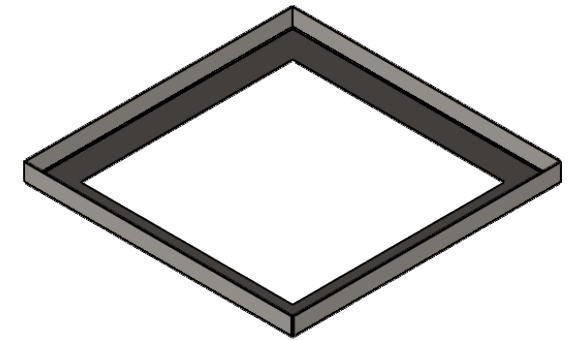
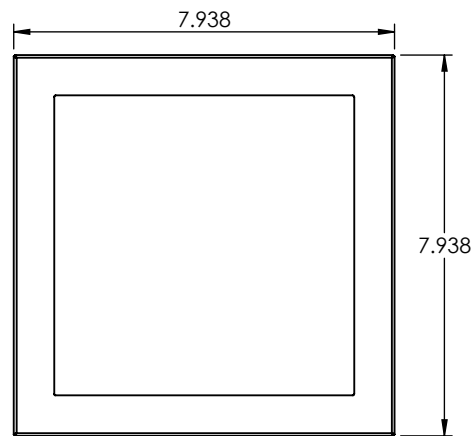
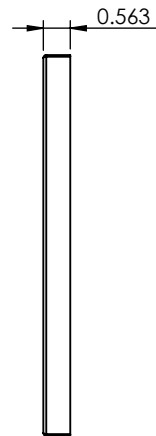
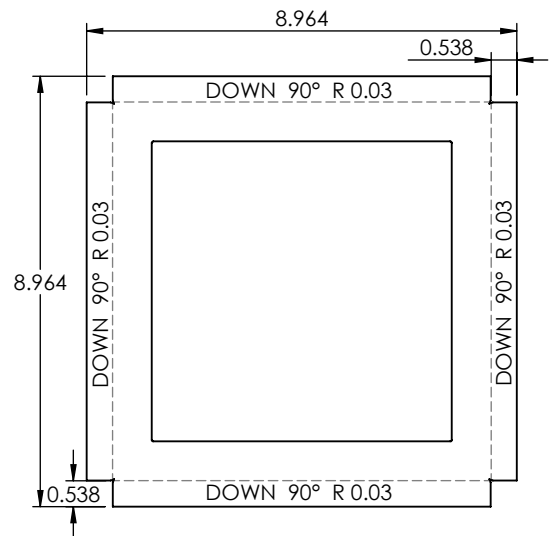
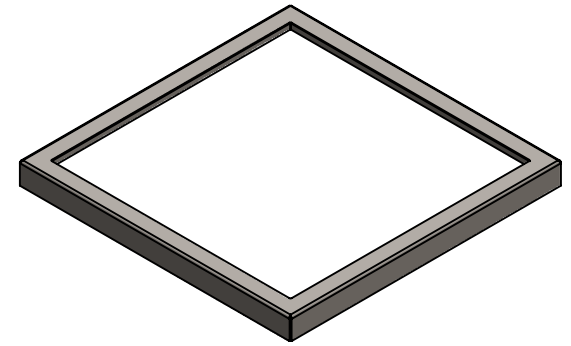
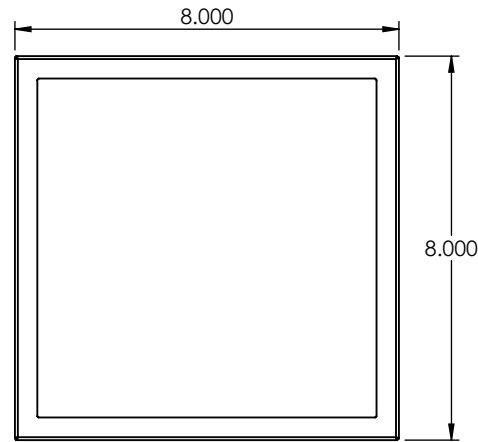
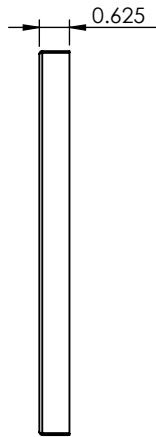
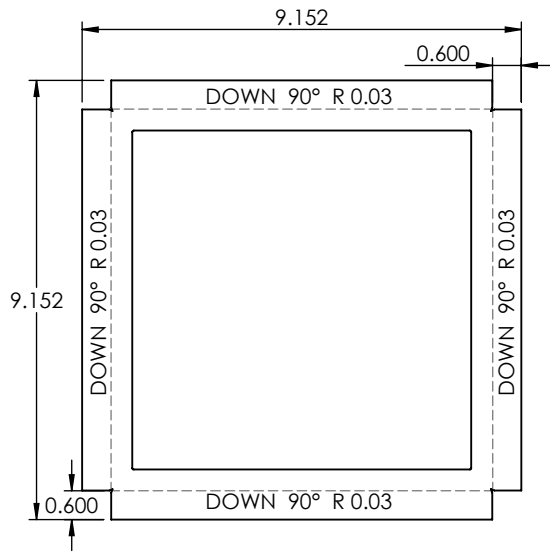

**PROPRIETARY AND CONFIDENTIAL**  
THE INFORMATION CONTAINED IN THIS DRAWING IS THE SOLE PROPERTY OF <INSERT COMPANY NAME HERE>. ANY REPRODUCTION IN PART OR AS A WHOLE WITHOUT THE WRITTEN PERMISSION OF <INSERT COMPANY NAME HERE> IS PROHIBITED.

NEXT ASSY	USED ON

APPLICATION

UNLESS OTHERWISE SPECIFIED:  
DIMENSIONS ARE IN INCHES  
TOLERANCES:  
FRACTIONAL ±  
ANGULAR: MACH ± BEND ±  
TWO PLACE DECIMAL ±  
THREE PLACE DECIMAL ±

INTERPRET GEOMETRIC TOLERANCING PER:  
MATERIAL  
FINISH

DO NOT SCALE DRAWING

	NAME	DATE
DRAWN		
CHECKED		
ENG APPR.		
MFG APPR.		
Q.A.		

COMMENTS:

<b>22 GAUGE</b>		
TITLE: <b>802320L-AB-A-AA-41K</b>		
SIZE <b>A</b>	DWG. NO.	REV
SCALE: 1:4	WEIGHT:	SHEET 5 OF 10

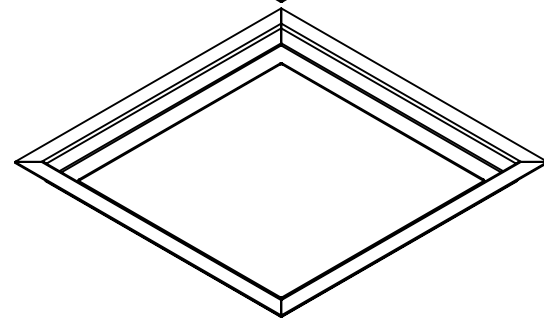
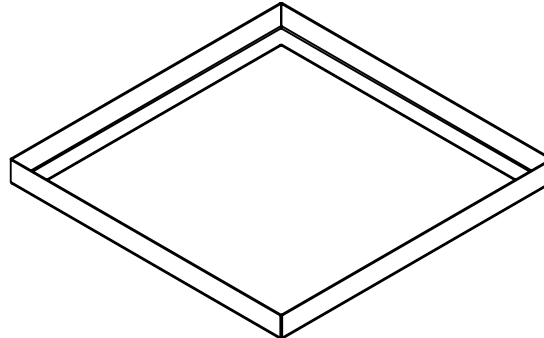
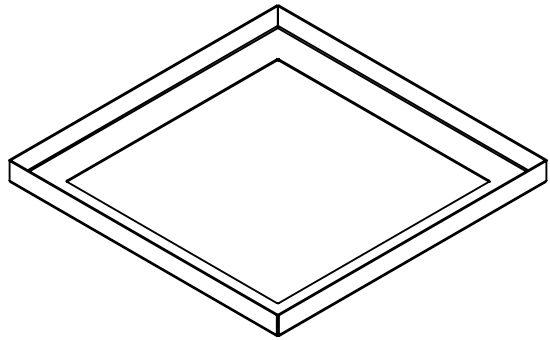
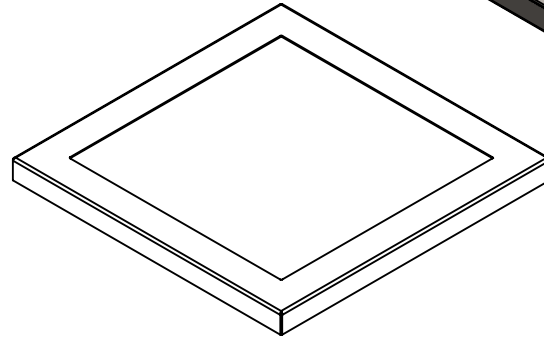
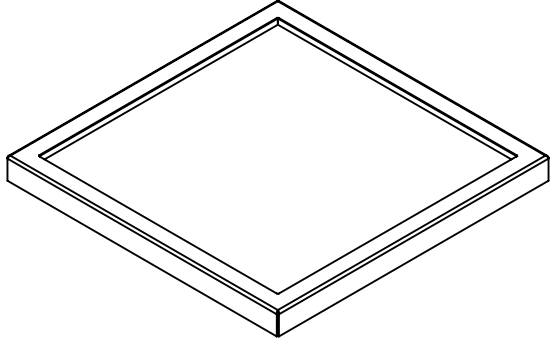
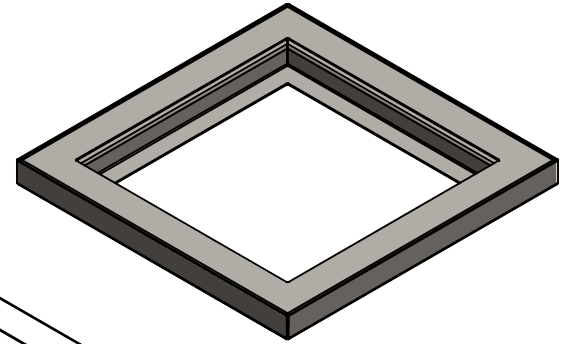
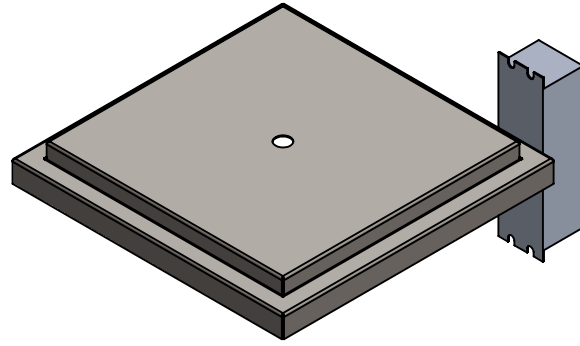
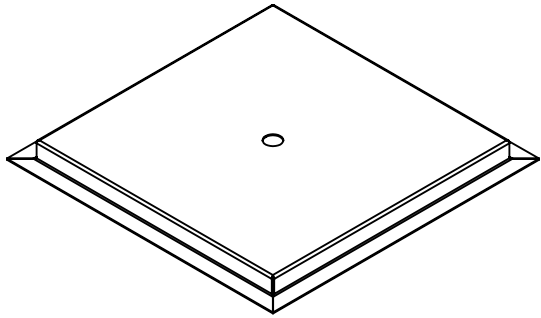

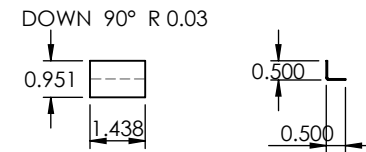
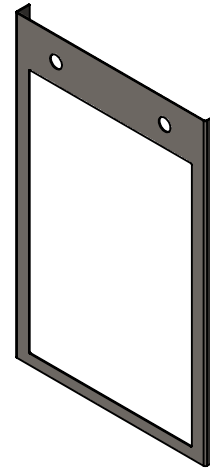
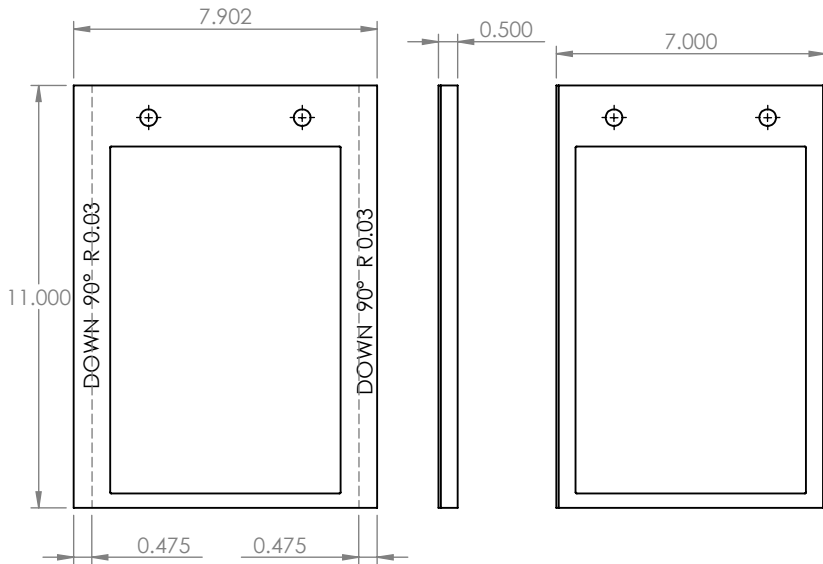
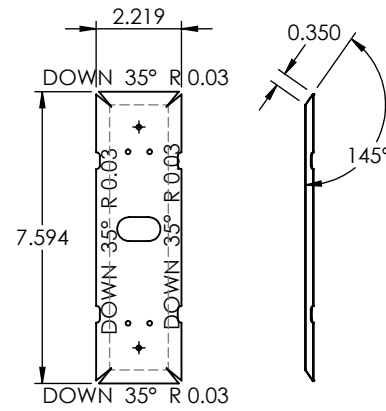
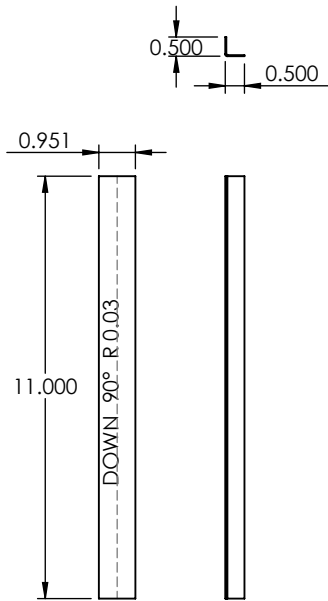

UNLESS OTHERWISE SPECIFIED:		NAME	DATE	22 GAUGE	
DIMENSIONS ARE IN INCHES TOLERANCES: FRACTIONAL ± ANGULAR: MACH ± BEND ± TWO PLACE DECIMAL ± THREE PLACE DECIMAL ±		DRAWN			
INTERPRET GEOMETRIC TOLERANCING PER:		CHECKED		SIZE DWG. NO. REV	
MATERIAL		ENG APPR.			
FINISH		MFG APPR.		SCALE: 1:5 WEIGHT: SHEET 7 OF 10	
NEXT ASSY	USED ON	Q.A.			
APPLICATION		DO NOT SCALE DRAWING			

**PROPRIETARY AND CONFIDENTIAL**  
THE INFORMATION CONTAINED IN THIS DRAWING IS THE SOLE PROPERTY OF <INSERT COMPANY NAME HERE>. ANY REPRODUCTION IN PART OR AS A WHOLE WITHOUT THE WRITTEN PERMISSION OF <INSERT COMPANY NAME HERE> IS PROHIBITED.

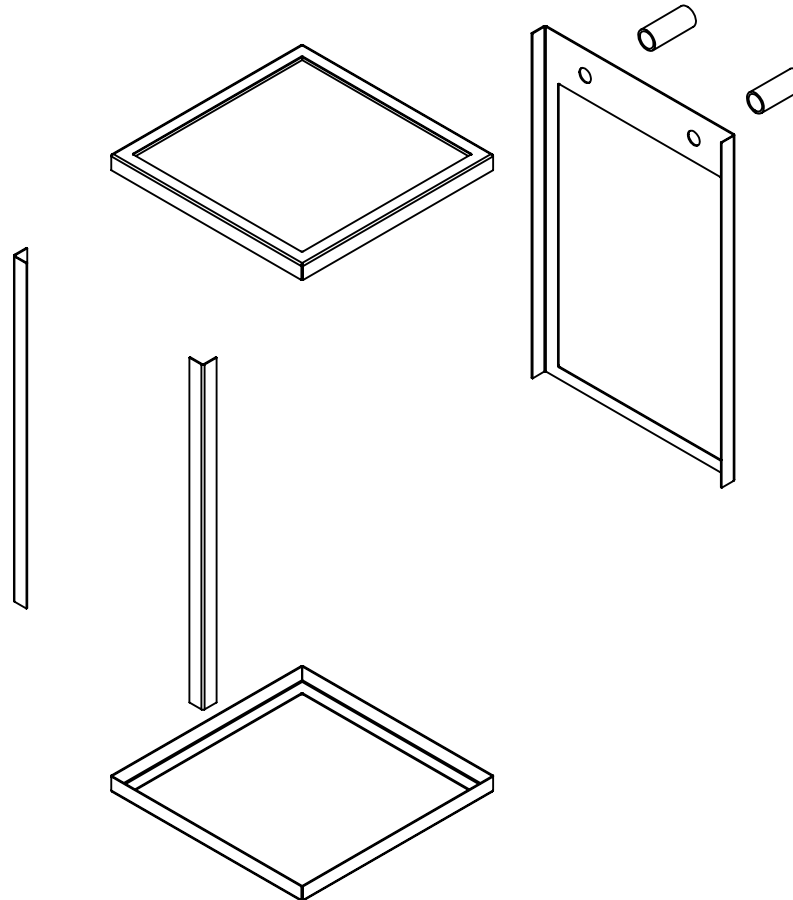
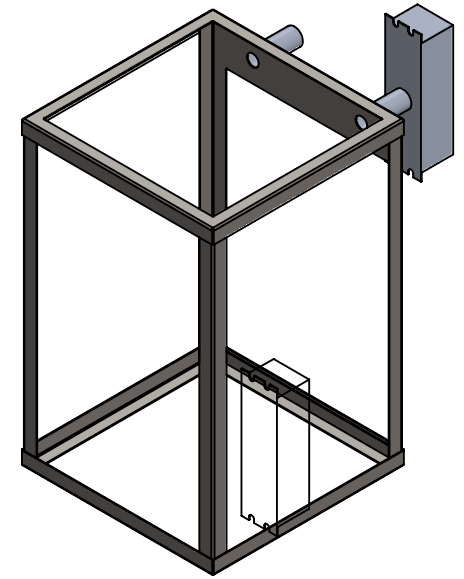
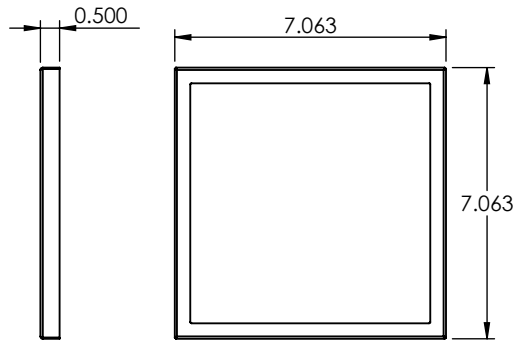
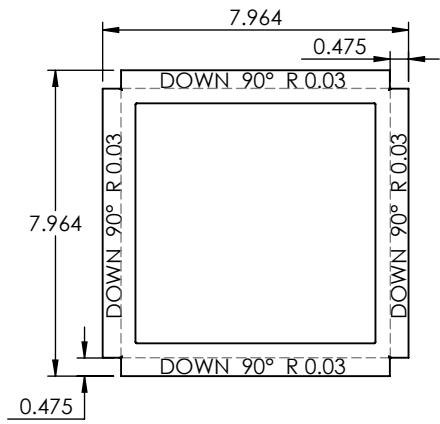



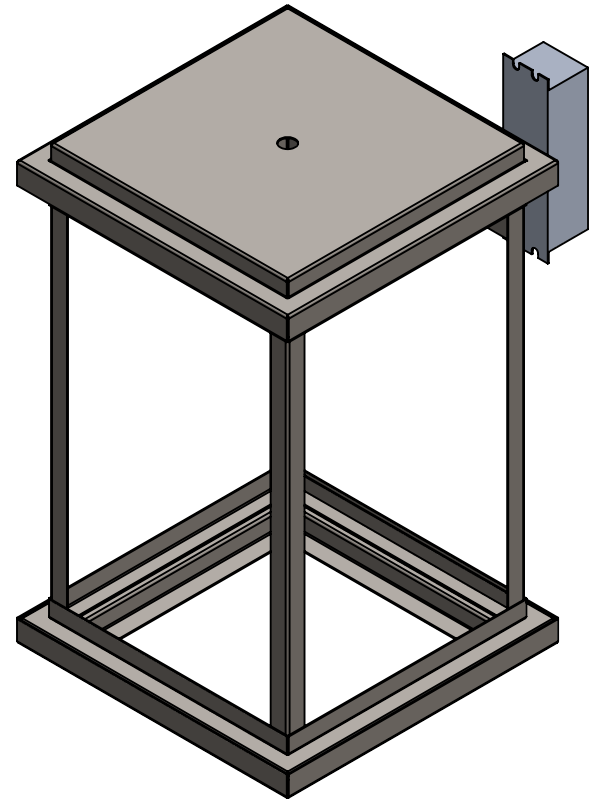
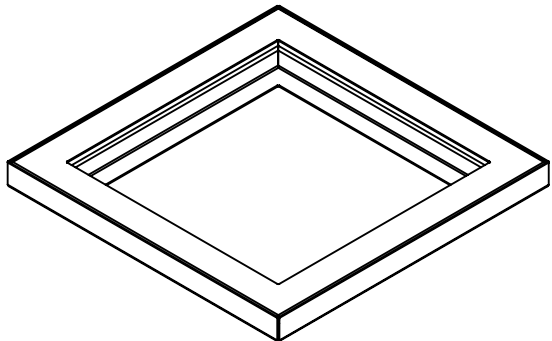
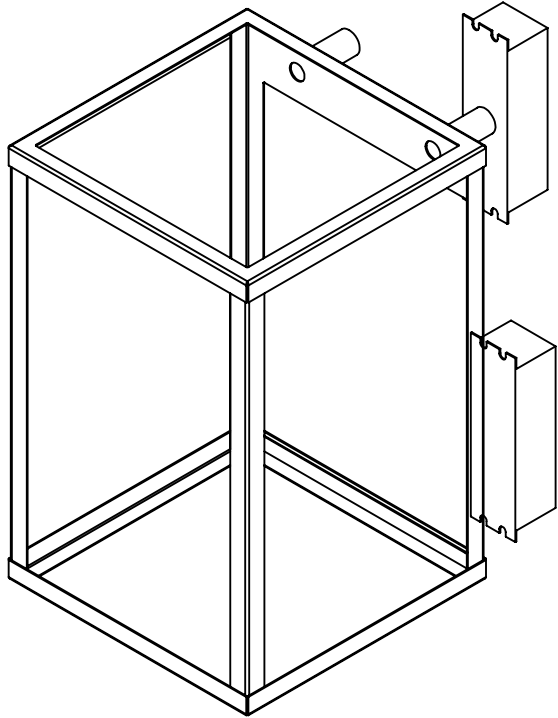
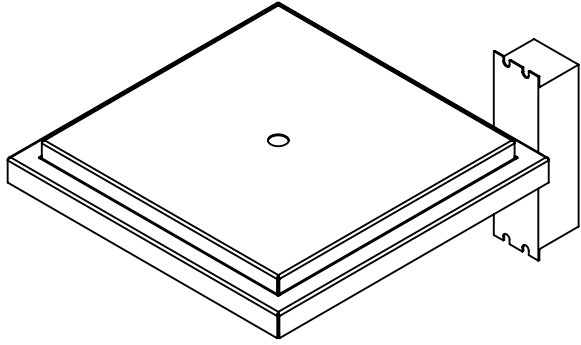

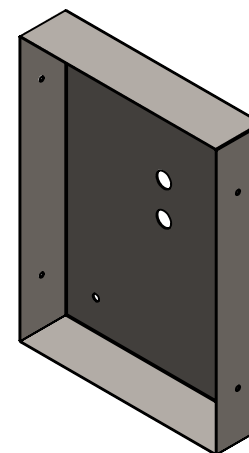
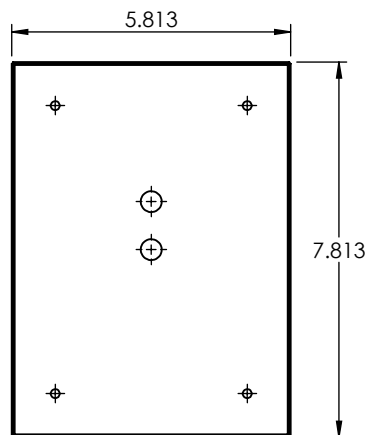
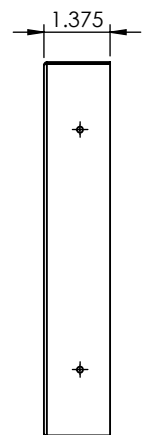
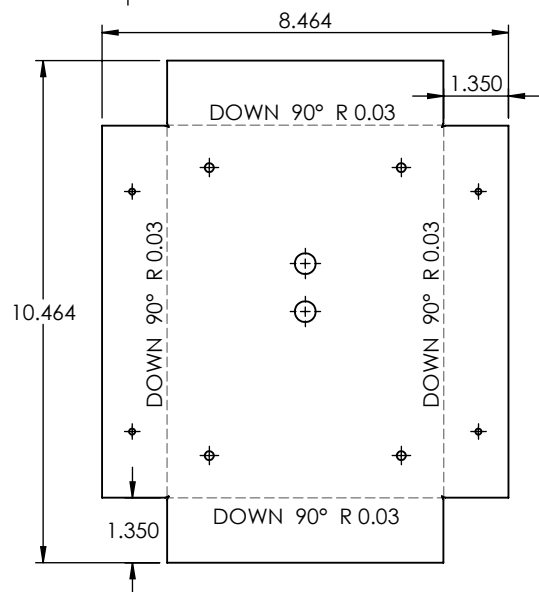
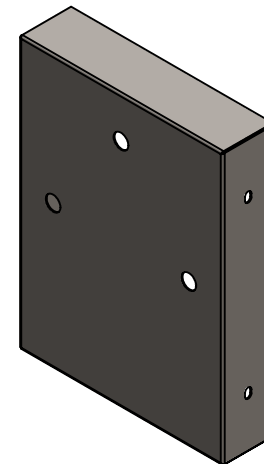
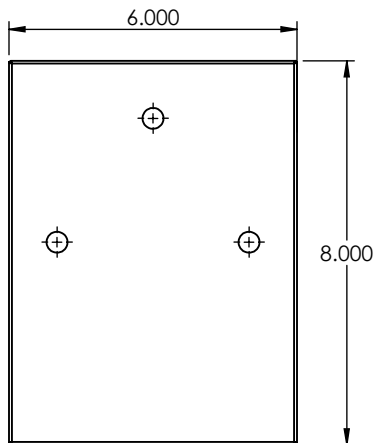
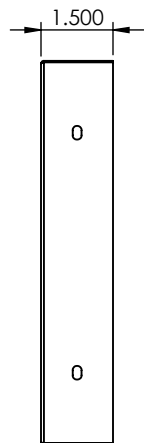
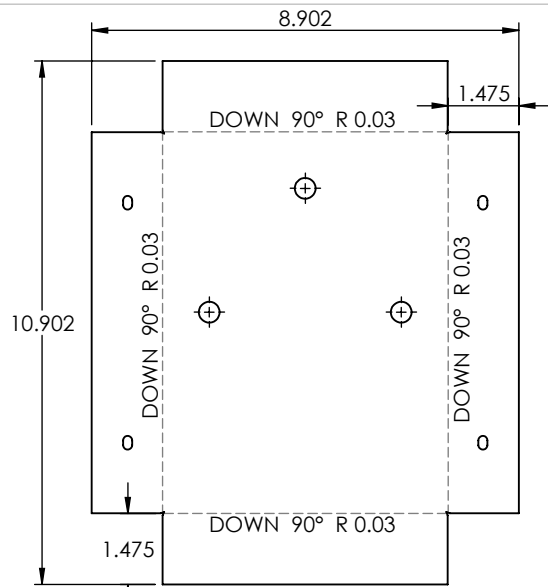

UNLESS OTHERWISE SPECIFIED:

DIMENSIONS ARE IN INCHES  
 TOLERANCES:  
 FRACTIONAL ±  
 ANGULAR: MACH ± BEND ±  
 TWO PLACE DECIMAL ±  
 THREE PLACE DECIMAL ±

INTERPRET GEOMETRIC  
 TOLERANCING PER:

MATERIAL

FINISH

DO NOT SCALE DRAWING

NAME

DATE

DRAWN

CHECKED

ENG APPR.

MFG APPR.

Q.A.

COMMENTS:

22 GAUGE

TITLE:

802320L-AB-A-AA-41K

SIZE  
**A**

DWG. NO.

REV

SCALE: 1:4

WEIGHT:

SHEET 10 OF 10

**PROPRIETARY AND CONFIDENTIAL**

THE INFORMATION CONTAINED IN THIS DRAWING IS THE SOLE PROPERTY OF <INSERT COMPANY NAME HERE>. ANY REPRODUCTION IN PART OR AS A WHOLE WITHOUT THE WRITTEN PERMISSION OF <INSERT COMPANY NAME HERE> IS PROHIBITED.

NEXT ASSY

USED ON

APPLICATION